

**2N4901 – 2N4902 – 2N4903**
**PNP SILICON TRANSISTORS, EPITAXIAL BASE**

LF Large signal power amplification  
Switching medium current

**ABSOLUTE MAXIMUM RATINGS**

Symbol	Ratings		Value	Unit	
$V_{CBO}$	Collector to Base Voltage	2N4901	-40	V	
		2N4902	-60		
		2N4903	-80		
$V_{CEO}$	#Collector-Emitter Voltage	2N4901	-40	V	
		2N4902	-60		
		2N4903	-80		
$V_{CER}$	Collector-Emitter Voltage	2N4901	-40	V	
		2N4902	-60		
		2N4903	-80		
$V_{EBO}$	Emitter-Base Voltage	2N4901	-5.0	V	
		2N4902			
		2N4903			
$V_{CEX}$	Collector-Base Voltage	$V_{BE}=1.5\text{ V}$	2N4901	V	
			2N4902		-60
			2N4903		-80
$I_C$	Collector Current – Continuous	2N4901	-5	A	
		2N4902			
		2N4903			
$I_{CM}$	Collector Current – Peak	$t_p=5\text{ ms}$	2N4901	-10	A
			2N4902		
			2N4903		
$I_B$	Base Current – Continuous	2N4901	-1	A	
		2N4902			
		2N4903			
$P_{TOT}$	Power Dissipation	2N4901	87.5	W	
		2N4902			
		2N4903			
$T_J$	Junction Temperature	2N4901	200	°C	
		2N4902			
		2N4903			
$T_{STG}$	Storage Temperature	2N4901	-65 to +200	°C	
		2N4902			
		2N4903			

# 2N4901 – 2N4902 – 2N4903

## THERMAL CHARACTERISTICS

Symbol	Ratings	Value	Unit
$R_{thJC}$	Thermal Resistance, Junction to Case	2	°C/W
$R_{thJA}$	Junction to Free Air Thermal Resistance	47.3	°C/W

## ELECTRICAL CHARACTERISTICS

TC=25°C unless otherwise noted

Symbol	Ratings	Test Condition(s)	Min	Typ	Mx	Unit	
$V_{CE0(BR)}$	Collector-Emitter Breakdown Voltage)	$I_C=200\text{ mA dc}, I_B=0$	2N4901	-40	-	-	V
			2N4902	-60	-	-	
			2N4903	-80	-	-	
$I_{CBO}$	Collector-Base cut-off Current	$V_{CE}=-40\text{ V}, I_E=0$	2N4901	-	-	1.0	mA
		$V_{CE}=-60\text{ V}, I_E=0$	2N4902	-	-	1.0	
		$V_{CE}=-80\text{ V}, I_E=0$	2N4903	-	-	1.0	
$I_{CEO}$	Collector-Emitter cut-off Current	$V_{CE}=-40\text{ V}, I_B=0$	2N4901	-	-	1.0	mA
		$V_{CE}=-60\text{ V}, I_B=0$	2N4902	-	-	1.0	
		$V_{CE}=-80\text{ V}, I_B=0$	2N4903	-	-	1.0	
$I_{CEX}$	Collector Cutoff Current	$V_{CE}=-40\text{ V}, V_{EB}=1.5\text{ V}$	2N4901	-	-	-0.1	mA
		$V_{CE}=-40\text{ V}, V_{EB}=1.5\text{ V}, T_{CASE}=150^\circ\text{C}$		-	-	-2.0	
		$V_{CE}=-60\text{ V}, V_{EB}=1.5\text{ V}$	2N4902	-	-	-0.1	
		$V_{CE}=-60\text{ V}, V_{EB}=1.5\text{ V}, T_{CASE}=150^\circ\text{C}$		-	-	-2.0	
		$V_{CE}=-80\text{ V}, V_{EB}=1.5\text{ V}$	2N4903	-	-	-0.1	
		$V_{CE}=-60\text{ V}, V_{EB}=1.5\text{ V}, T_{CASE}=150^\circ\text{C}$		-	-	-2.0	
$h_{21E}$	DC Current Gain (*)	$V_{CE}=-2.0\text{ V}, I_C=-1.0\text{ A}$	2N4901 2N4902 2N4903	20	-	80	V
		$V_{CE}=-2.0\text{ V}, I_C=-5.0\text{ A}$	2N4901 2N4902 2N4903	7	-	-	
$h_{21e}$	Forward Current Transfer Ratio (*)	$V_{CE}=-10\text{ V}, I_C=-0.5\text{ A}, f=1.0\text{ kHz}$	2N4901 2N4902 2N4903	20	-	-	V
$V_{CE(SAT)}$	Collector-Emitter saturation Voltage (*)	$I_C=-1.0\text{ A}, I_B=-0.1\text{ A}$	2N4901 2N4902 2N4903	-	-	-0.4	V
		$I_C=-5.0\text{ A}, I_B=-1.0\text{ A}$	2N4901 2N4902 2N4903	-	-	-1.5	

# 2N4901 – 2N4902 – 2N4903

Symbol	Ratings	Test Condition(s)	Min	Typ	Mx	Unit	mA
$V_{BE(SAT)}$	Base-Emitter Saturation Voltage (*)	$I_C=-5.0\text{ A}$ , $I_B=-1.0\text{ A}$	2N4901 2N4902 2N4903	-	1.7	-	V
$V_{BE}$	Base-Emitter Voltage (*)	$I_C=-1.0\text{ A}$ , $V_{CE}=-2.0\text{ V}$	2N4901 2N4902 2N4903	-	-	-1.2	V
$f_T$	Transition Frequency	$V_{CE}=-10\text{ V}$ , $I_C=-1.0\text{ A}$ , $f=1.0\text{ kHz}$	2N4901 2N4902 2N4903	4	-	-	MHz
$I_{s/b}$	Second Breakdown Collector Current	$t=1\text{ s}$ , $V_{CE}=40\text{ V}$ , $T_{CASE}=100^\circ\text{C}$	2N4901 2N4902 2N4903	1.25	-	-	A

In accordance with JEDEC Registration Data

(\*) Pulse Width  $\approx 300\ \mu\text{s}$ , Duty Cycle  $\angle 2.0\%$

## MECHANICAL DATA CASE TO-3

DIMENSIONS		
	mm	inches
A	25,45	1
B	38,8	1,52
C	30,09	1,184
D	17,11	0,67
E	9,78	0,38
G	11,09	0,43
H	8,33	0,32
L	1,62	0,06
M	19,43	0,76
N	1	0,04
P	4,08	0,16

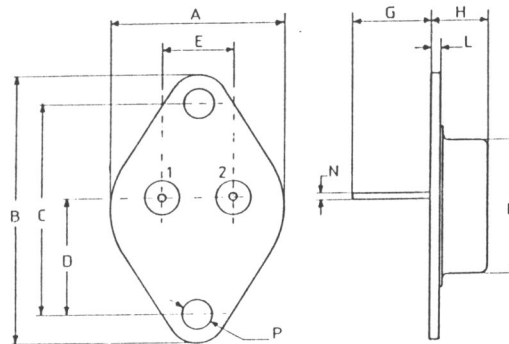

Pin 1 :	Base
Pin 2 :	Emitter
Case :	Collector

*Information furnished is believed to be accurate and reliable. However, CS assumes no responsibility for the consequences of use of such information nor for errors that could appear.  
Data are subject to change without notice.*