



Micro Commercial Components
 21201 Itasca Street Chatsworth
 CA 91311
 Phone: (818) 701-4933
 Fax: (818) 701-4939

MMBD1501(A) THRU MMBD1505(A)

Features

- Low Leakage
- Surface Mount Package Ideally Suited for Automatic Insertion
- 150°C Junction Temperature
- High Conductance

Mechanical Data

- Case: SOT-23, Molded Plastic
- Terminals: Solderable per MIL-STD-202, Method 208
- Polarity: See Diagram
- Weight: 0.008 grams (approx.)

Maximum Ratings @ 25°C Unless Otherwise Specified

Characteristic	Symbol	Value	Unit
Working Inverse Voltage	V_{IV}	180	V
DC Forward Current	I_F	600	mA
Average Rectified Current	I_o	200	mA
Recurrent Peak Forward Current	i_f	700	mA
Peak Forward Surge Current @ $t=1.0s$ @ $t=1.0ms$	$i_{f(surge)}$	1.0 2.0	A
Power Dissipation	P_d	350	mW
Thermal Resistance	R	357	°C/W
Operation & Storage Temp. Range	T_j, T_{STG}	-55 to +150	°C

Note: 1) These ratings are based on a max. junction temperature of 150 degrees C
 2) These are steady state limits. The factory should be consulted on applications involving pulsed or low duty cycle operation

Electrical Characteristics @ 25°C Unless Otherwise Specified

Charateristic	Symbol	Min	Max	Unit	Test Cond.
Breakdown Voltage	B_V	200		V	$I_R=5.0uA$
Forward Voltage Drop	V_F	620	750	mV	$I_F=1.0mA$
		720	850	mV	$I_F=10mA$
		800	950	mV	$I_F=50mA$
		0.83	1.1	V	$I_F=100mA$
		0.87	1.3	V	$I_F=200mA$
		0.9	1.5	V	$I_F=300mA$
Reverse Current	I_R		1.0	nA	$V_R=125V$
			3.0	uA	$V_R=125V T_A=150°C$
			10	nA	$V_R=180V$
			5.0	uA	$V_R=180V T_A=150°C$
Junction Capacitance	C_j		4	pF	$V_R=0V, f=1.0MHz$

**High Conductance
 Low Leakage Diode
 350mW**

SOT-23

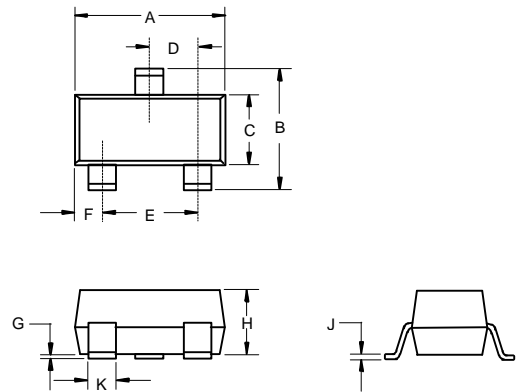

DIM	INCHES		MM		NOTE
	MIN	MAX	MIN	MAX	
A	.110	.120	2.80	3.04	
B	.083	.098	2.10	2.64	
C	.047	.055	1.20	1.40	
D	.035	.041	.89	1.03	
E	.070	.081	1.78	2.05	
F	.018	.024	.45	.60	
G	.0005	.0039	.013	.100	
H	.035	.044	.89	1.12	
J	.003	.007	.085	.180	
K	.015	.020	.37	.51	

Suggested Solder Pad Layout

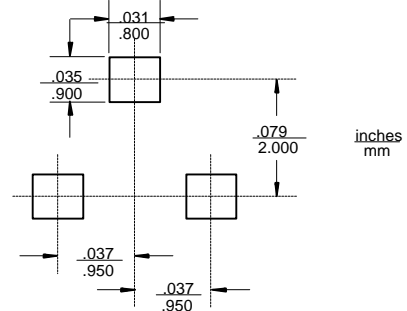

MMBD1501(A) thru MMBD1505(A)

REVERSE VOLTAGE vs REVERSE CURRENT
BV - 3.0 to 100 μ A

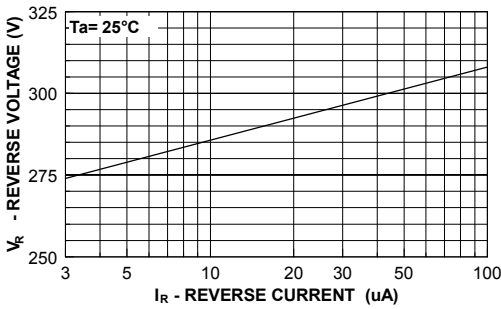

REVERSE CURRENT vs REVERSE VOLTAGE
IR - 130 - 205 Volts

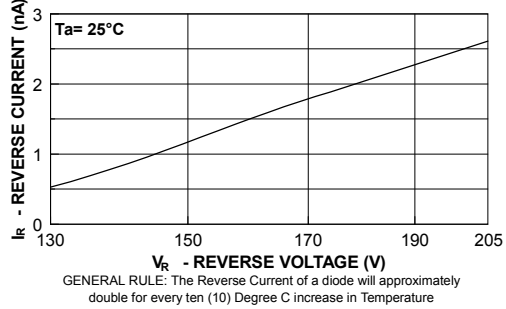

FORWARD VOLTAGE vs FORWARD CURRENT
VF - 1 to 100 μ A

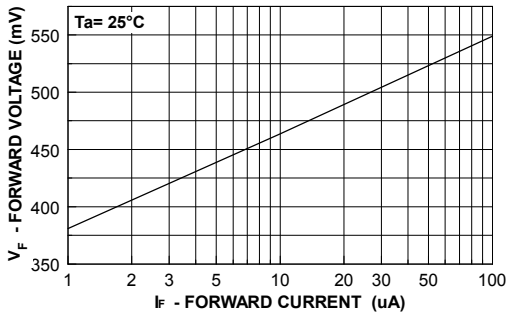

FORWARD VOLTAGE vs FORWARD CURRENT
VF - 0.1 to 10 mA

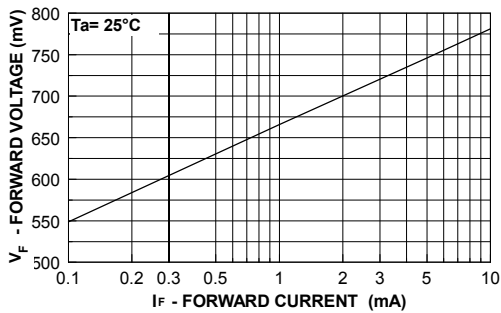

FORWARD VOLTAGE vs FORWARD CURRENT
VF - 10 to 800 mA

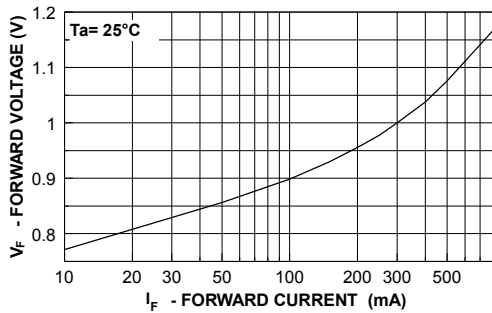

CAPACITANCE vs REVERSE VOLTAGE
VR - 0 to 15 V

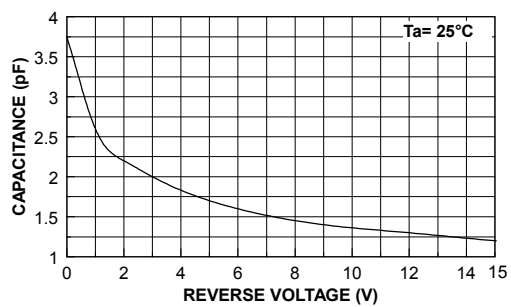

Average Rectified Current (I_o) & Forward Current (I_f) versus Ambient Temperature (T_A)

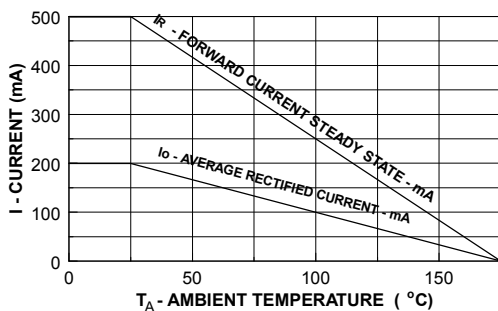

POWER DERATING CURVE

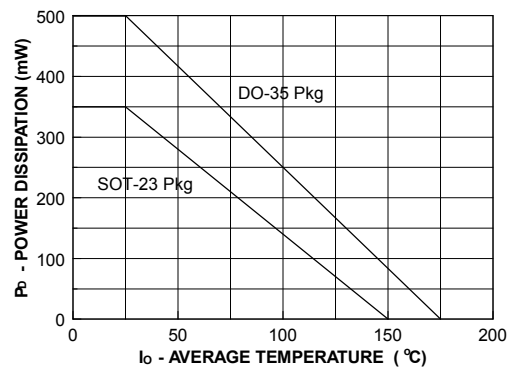

MMBD1501(A) thru MMBD1505(A)

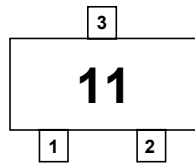

MARKING

MMBD1501	11	MMBD1501A	A11
MMBD1503	13	MMBD1503A	A13
MMBD1504	14	MMBD1504A	A14
MMBD1505	15	MMBD1505A	A15

