



Micro Commercial Components  
 21201 Itasca Street Chatsworth  
 CA 91311  
 Phone: (818) 701-4933  
 Fax: (818) 701-4939

# MMBT3906

## PNP General Purpose Amplifier

### Features

- Surface Mount SOT-23 Package
- Capable of 350mWatts of Power Dissipation

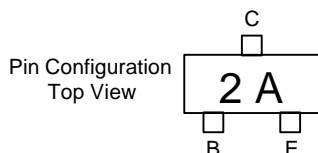

### Electrical Characteristics @ 25°C Unless Otherwise Specified

Symbol	Parameter	Min	Max	Units
<b>OFF CHARACTERISTICS</b>				
$V_{(BR)CEO}$	Collector-Emitter Breakdown Voltage* ( $I_C=1.0mA$ , $I_B=0$ )	40		Vdc
$V_{(BR)CBO}$	Collector-Base Breakdown Voltage ( $I_C=10\mu A$ , $I_E=0$ )	40		Vdc
$V_{(BR)EBO}$	Emitter-Base Breakdown Voltage ( $I_E=10\mu A$ , $I_C=0$ )	5.0		Vdc
$I_{BL}$	Base Cutoff Current ( $V_{CE}=30Vdc$ , $V_{BE}=3.0Vdc$ )		50	nAdc
$I_{CEX}$	Collector Cutoff Current ( $V_{CE}=30Vdc$ , $V_{BE}=3.0Vdc$ )		50	nAdc

### ON CHARACTERISTICS

$h_{FE}$	DC Current Gain* ( $I_C=0.1mA$ , $V_{CE}=1.0Vdc$ ) ( $I_C=1.0mA$ , $V_{CE}=1.0Vdc$ ) ( $I_C=10mA$ , $V_{CE}=1.0Vdc$ ) ( $I_C=50mA$ , $V_{CE}=1.0Vdc$ ) ( $I_C=100mA$ , $V_{CE}=1.0Vdc$ )	60 80 100 60 30	300	
$V_{CE(sat)}$	Collector-Emitter Saturation Voltage ( $I_C=10mA$ , $I_B=1.0mA$ ) ( $I_C=50mA$ , $I_B=5.0mA$ )		0.25 0.4	Vdc
$V_{BE(sat)}$	Base-Emitter Saturation Voltage ( $I_C=10mA$ , $I_B=1.0mA$ ) ( $I_C=50mA$ , $I_B=5.0mA$ )	0.65	0.85 0.95	Vdc

### SMALL-SIGNAL CHARACTERISTICS

$f_T$	Current Gain-Bandwidth Product ( $I_C=10mA$ , $V_{CE}=20Vdc$ , $f=100MHz$ )	250		MHz
$C_{obo}$	Output Capacitance ( $V_{CB}=5.0Vdc$ , $I_E=0$ , $f=1.0MHz$ )		4.5	pF
$C_{ibo}$	Input Capacitance ( $V_{BE}=0.5Vdc$ , $I_C=0$ , $f=1.0MHz$ )		10.0	pF
NF	Noise Figure ( $I_C=100\mu A$ , $V_{CE}=5.0Vdc$ , $R_S=1.0k\Omega$ , $f=10Hz$ to $15.7kHz$ )		4.0	dB

### SWITCHING CHARACTERISTICS

$t_d$	Delay Time	( $V_{CC}=3.0Vdc$ , $V_{BE}=0.5Vdc$ )	35	ns
$t_r$	Rise Time	( $I_C=10mA$ , $I_{B1}=1.0mA$ )	35	ns
$t_s$	Storage Time	( $V_{CC}=3.0Vdc$ , $I_C=10mA$ )	225	ns
$t_f$	Fall Time	( $I_{B1}=I_{B2}=1.0mA$ )	75	ns

\*Pulse Width  $\leq 300\mu s$ , Duty Cycle  $\leq 2.0\%$

### SOT-23

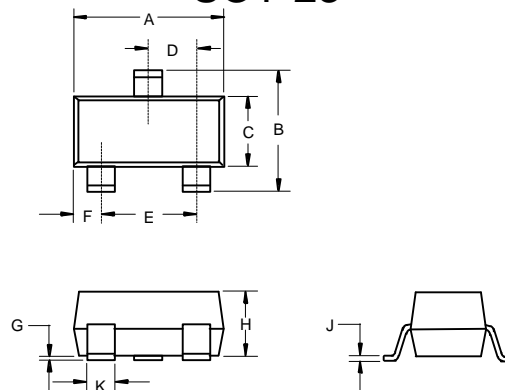

DIM	INCHES		MM		NOTE
	MIN	MAX	MIN	MAX	
A	.110	.120	2.80	3.04	
B	.083	.098	2.10	2.64	
C	.047	.055	1.20	1.40	
D	.035	.041	.89	1.03	
E	.070	.081	1.78	2.05	
F	.018	.024	.45	.60	
G	.0005	.0039	.013	.100	
H	.035	.044	.89	1.12	
J	.003	.007	.085	.180	
K	.015	.020	.37	.51	

### Suggested Solder Pad Layout

