

#### FEATURES

- Monolithic 25 MSPS converter
- 135 mW power dissipation
- On-chip track-and-hold
- Single +5 V power supply
- TTL/CMOS outputs
- 5 pF input capacitance
- Low cost
- Tri-state output buffers
- High ESD protection: 3,500 V minimum
- Selectable +3 V or +5 V logic I/O

#### APPLICATIONS

- All high-speed applications where low power dissipation is required
- Video imaging
- Medical imaging
- IR imaging
- Digital communications

#### GENERAL DESCRIPTION

The SPT7855 is a 10-bit monolithic, low-cost, ultralow-power analog-to-digital converter capable of minimum word rates of 25 MSPS. The on-chip track-and-hold function assures very good dynamic performance without the need for external components. The input drive requirements are minimized due to the SPT7855's low input capacitance of only 5 pF.

Power dissipation is extremely low at only 135 mW typical at 25 MSPS with a power supply of +5.0 V. The digital outputs are +3 V or +5 V, and are user selectable. The

SPT7855 is pin-compatible with the entire family of SPT 10-bit, CMOS converters (SPT7835/40/50/55/60/61), which simplifies upgrades. The SPT7855 has incorporated proprietary circuit design\* and CMOS processing technologies to achieve its advanced performance. Inputs and outputs are TTL/CMOS-compatible to interface with TTL/CMOS logic systems. Output data format is straight binary.

The SPT7855 is available in 28-lead SOIC and 32-lead small (7 mm square) TQFP packages over the commercial and industrial temperature ranges.

\*Patent pending

#### BLOCK DIAGRAM

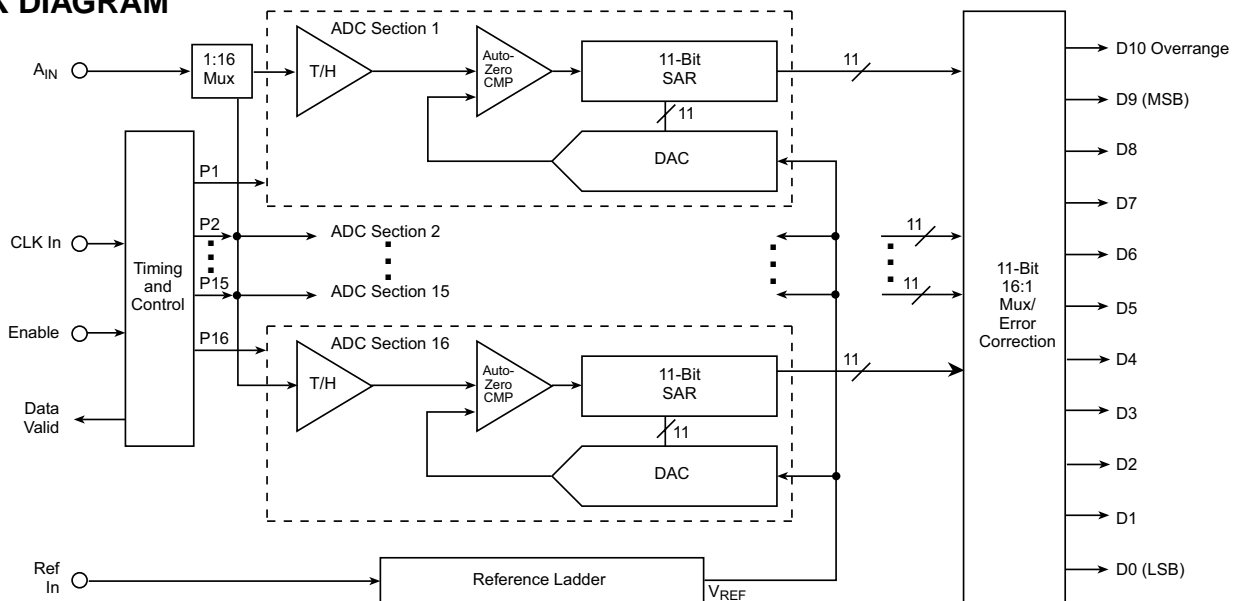

**Signal Processing Technologies, Inc.**

4755 Forge Road, Colorado Springs, Colorado 80907, USA

Phone: 719-528-2300

Fax: 719-528-2370

Web Site: <http://www.spt.com>

e-mail: [sales@spt.com](mailto:sales@spt.com)

## ABSOLUTE MAXIMUM RATINGS (Beyond which damage may occur)<sup>1</sup> 25 °C

### Supply Voltages

AV <sub>DD</sub> .....	+6 V
DV <sub>DD</sub> .....	+6 V

### Input Voltages

Analog Input .....	-0.5 V to AV <sub>DD</sub> +0.5 V
V <sub>REF</sub> .....	0 to AV <sub>DD</sub>
CLK Input .....	V <sub>DD</sub>
AV <sub>DD</sub> - DV <sub>DD</sub> .....	±100 mV
AGND - DGND .....	±100 mV

### Output

Digital Outputs .....	10 mA
-----------------------	-------

### Temperature

Operating Temperature .....	-40 to 85 °C
Junction Temperature .....	175 °C
Lead Temperature, (soldering 10 seconds) .....	300 °C
Storage Temperature .....	-65 to +150 °C

**Note:** 1. Operation at any Absolute Maximum Rating is not implied. See Electrical Specifications for proper nominal applied conditions in typical applications.

## ELECTRICAL SPECIFICATIONS

T<sub>A</sub>=T<sub>MIN</sub> to T<sub>MAX</sub>, AV<sub>DD</sub>=DV<sub>DD</sub>=+5.0 V, V<sub>IN</sub>=0 to 4 V, f<sub>CLK</sub>=25 MSPS, V<sub>RHS</sub>=4.0 V, V<sub>RLS</sub>=0.0 V, unless otherwise specified.

PARAMETERS	TEST CONDITIONS	TEST LEVEL	SPT7855			UNITS
			MIN	TYP	MAX	
<b>Resolution</b>			10			Bits
<b>DC Accuracy</b>						
Integral Linearity Error (ILE)		VI		±1.0		LSB
Differential Linearity Error (DLE)		VI		±0.5		LSB
No Missing Codes		VI		Guaranteed		
<b>Analog Input</b>						
Input Voltage Range	(Small Signal)	VI			V <sub>RHS</sub>	V
Input Resistance		IV	V <sub>RLS</sub>			kΩ
Input Capacitance		V	50			pF
Input Bandwidth		V		5.0		MHz
Offset		V		±2.0		LSB
Gain Error		V		±2.0		LSB
<b>Reference Input</b>						
Resistance		VI	300	500	600	Ω
Bandwidth		V	100	150		MHz
Voltage Range						
V <sub>RLS</sub>		IV	0	-	2.0	V
V <sub>RHS</sub>		IV	3.0	-	AV <sub>DD</sub>	V
V <sub>RHS</sub> - V <sub>RLS</sub>		V	1.0	4.0	5.0	V
Δ(V <sub>RHF</sub> - V <sub>RHS</sub> )		V		90		mV
Δ(V <sub>RLS</sub> - V <sub>RLF</sub> )		V		75		mV
<b>Reference Settling Time</b>						
V <sub>RHS</sub>		V		15		Clock Cycles
V <sub>RLS</sub>		V		20		Clock Cycles
<b>Conversion Characteristics</b>						
Maximum Conversion Rate		VI	25			MHz
Minimum Conversion Rate		IV	2			MHz
Pipeline Delay (Latency)		IV			12	Clock Cycles
Aperture Delay Time		V		8		ns
Aperture Jitter Time		V			15	ps (p-p)
<b>Dynamic Performance</b>						
Effective Number of Bits (ENOB)						
f <sub>IN</sub> = 3.58 MHz		VI		8.5		Bits
f <sub>IN</sub> = 10.3 MHz		VI		8.3		Bits
Signal-to-Noise Ratio (SNR) (without Harmonics)						
f <sub>IN</sub> = 3.58 MHz		VI	54.0	57		dB
f <sub>IN</sub> = 10.3 MHz		VI	53.0	56		dB

## ELECTRICAL SPECIFICATIONS

$T_A = T_{MIN}$  to  $T_{MAX}$ ,  $AV_{DD} = DV_{DD} = +5.0$  V,  $V_{IN} = 0$  to 4 V,  $f_{CLK} = 25$  MSPS,  $V_{RHS} = 4.0$  V,  $V_{RLS} = 0.0$  V, unless otherwise specified.

PARAMETERS	TEST CONDITIONS	TEST LEVEL	MIN	SPT7855 TYP	MAX	UNITS
<b>Dynamic Performance</b>						
Total Harmonic Distortion (THD)	9 Distortion bins from 1024 pt FFT	VI	55.5	59		dB
$f_{IN} = 3.58$ MHz		VI	51.5	54		dB
Signal-to-Noise and Distortion (SINAD)		VI	53.0	55		dB
$f_{IN} = 10.3$ MHz		VI	50.5	52		dB
Spurious Free Dynamic Range	$f_{IN} = 1$ MHz	V		63		dB
Differential Phase		V		$\pm 0.3$		Degree
Differential Gain		V			$\pm 0.3$	%
<b>Inputs</b>						
Logic 1 Voltage		VI	2.0			V
Logic 0 Voltage		VI			0.8	V
Maximum Input Current Low		VI	-10		+10	$\mu$ A
Maximum Input Current High		VI	-10		+10	$\mu$ A
Input Capacitance		VI		+5		pF
<b>Digital Outputs</b>						
Logic 1 Voltage	$I_{OH} = 0.5$ mA $I_{OL} = 1.6$ mA	VI	3.5			V
Logic 0 Voltage		VI			0.4	V
$t_{RISE}$	15 pF load	V		10		ns
$t_{FALL}$	15 pF load	V		10		ns
Output Enable to Data Output Delay	20 pF load, $T_A = +25$ °C	V		10		ns
	50 pF load over temp.	V		22		ns
<b>Power Supply Requirements</b>						
Voltages	$OV_{DD}$	IV	3.0		5.0	V
	$DV_{DD}$	IV	4.75	5.0	5.25	V
	$AV_{DD}$	IV	4.75	5.0	5.25	V
Currents	$AI_{DD}$	VI		16	20	mA
	$DI_{DD}$	VI		11	15	mA
Power Dissipation		VI		135	175	mW

### TEST LEVEL CODES

All electrical characteristics are subject to the following conditions:

All parameters having min/max specifications are guaranteed. The Test Level column indicates the specific device testing actually performed during production and Quality Assurance inspection. Any blank section in the data column indicates that the specification is not tested at the specified condition.

### LEVEL TEST PROCEDURE

I	100% production tested at the specified temperature.
II	100% production tested at $T_A = +25$ °C, and sample tested at the specified temperatures.
III	QA sample tested only at the specified temperatures.
IV	Parameter is guaranteed (but not tested) by design and characterization data.
V	Parameter is a typical value for information purposes only.
VI	100% production tested at $T_A = +25$ °C. Parameter is guaranteed over specified temperature range.

## SPECIFICATION DEFINITIONS

### APERTURE DELAY

Aperture delay represents the point in time, relative to the rising edge of the CLOCK input, that the analog input is sampled.

### APERTURE JITTER

The variations in aperture delay for successive samples.

### DIFFERENTIAL GAIN (DG)

A signal consisting of a sine wave superimposed on various DC levels is applied to the input. Differential gain is the maximum variation in the sampled sine wave amplitudes at these DC levels.

### DIFFERENTIAL PHASE (DP)

A signal consisting of a sine wave superimposed on various DC levels is applied to the input. Differential phase is the maximum variation in the sampled sine wave phases at these DC levels.

### EFFECTIVE NUMBER OF BITS (ENOB)

$SINAD = 6.02N + 1.76$ , where N is equal to the effective number of bits.

$$N = \frac{SINAD - 1.76}{6.02}$$

### INPUT BANDWIDTH

Small signal (50 mV) bandwidth (3 dB) of analog input stage.

### DIFFERENTIAL LINEARITY ERROR (DLE)

Error in the width of each code from its theoretical value. (Theoretical =  $V_{FS}/2^N$ )

### INTEGRAL LINEARITY ERROR (ILE)

Linearity error refers to the deviation of each individual code (normalized) from a straight line drawn from  $-FS$  through  $+FS$ . The deviation is measured from the edge of each particular code to the true straight line.

### OUTPUT DELAY

Time between the clock's triggering edge and output data valid.

### OVERVOLTAGE RECOVERY TIME

The time required for the ADC to recover to full accuracy after an analog input signal 125% of full scale is reduced to 50% of the full-scale value.

### SIGNAL-TO-NOISE RATIO (SNR)

The ratio of the fundamental sinusoid power to the total noise power. Harmonics are excluded.

### SIGNAL-TO-NOISE AND DISTORTION (SINAD)

The ratio of the fundamental sinusoid power to the total noise and distortion power.

### TOTAL HARMONIC DISTORTION (THD)

The ratio of the total power of the first 9 harmonics to the power of the measured sinusoidal signal.

### SPURIOUS FREE DYNAMIC RANGE (SFDR)

The ratio of the fundamental sinusoidal amplitude to the single largest harmonic or spurious signal.

**Figure 1A – Timing Diagram 1**

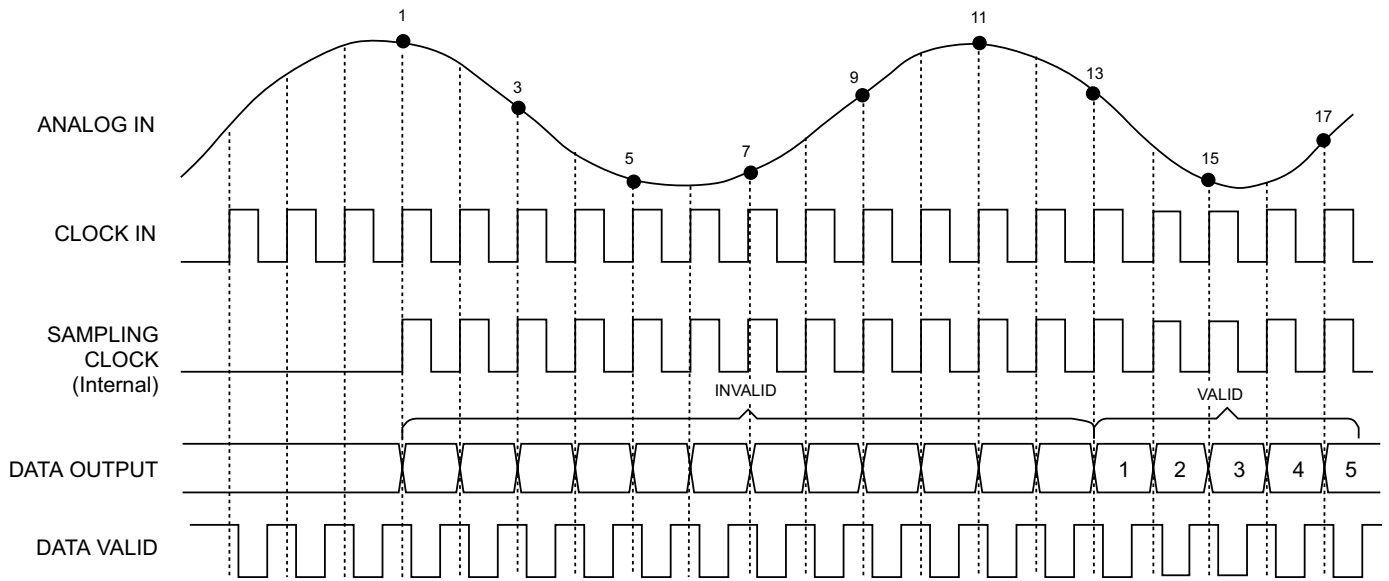

**Figure 1B – Timing Diagram 2**

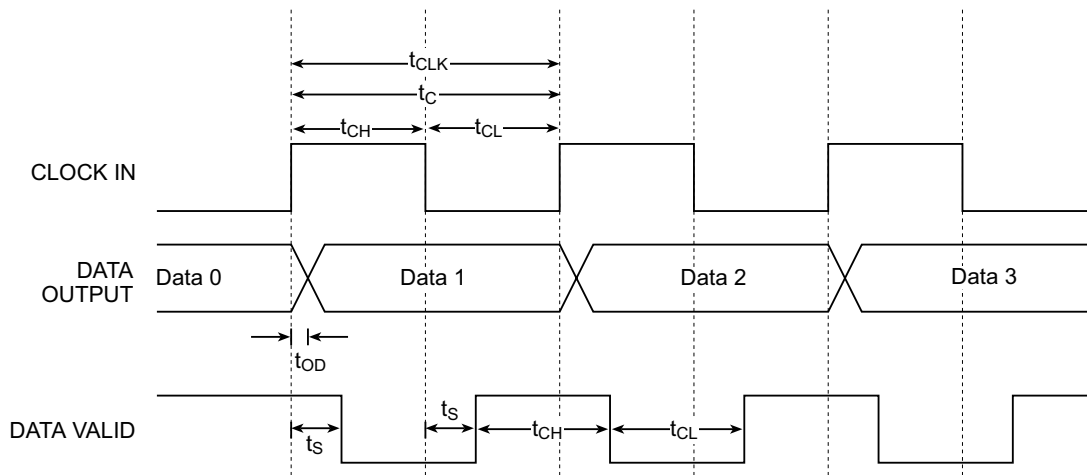

**Table I – Timing Parameters**

DESCRIPTION	PARAMETERS	MIN	TYP	MAX	UNITS
Conversion Time	$t_c$	$t_{CLK}$			ns
Clock Period	$t_{CLK}$	40			ns
Clock High Duty Cycle	$t_{CH}$	40	50	60	%
Clock Low Duty Cycle	$t_{CL}$	40	50	60	%
Clock to Output Delay (15 pF Load)	$t_{OD}$		17		ns
Clock to DAV	$t_s$		10		ns

**Figure 2 – Typical Interface Circuit**

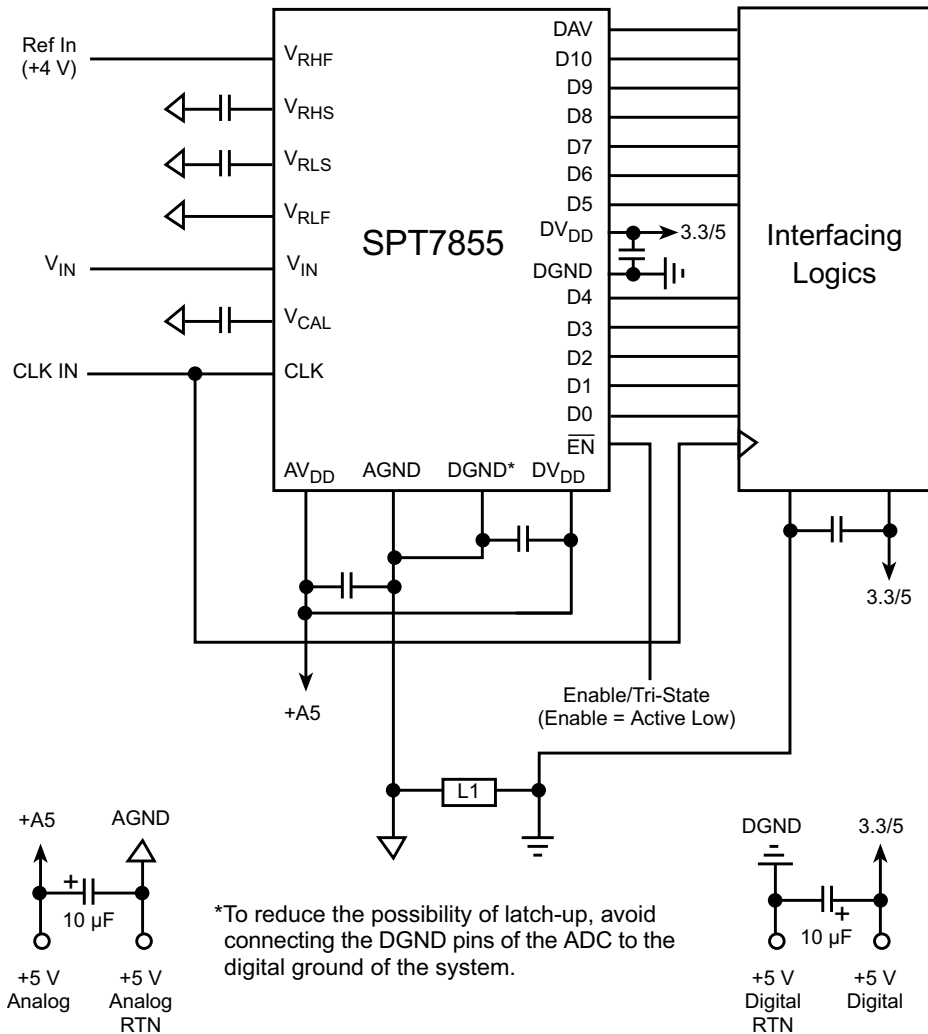

## TYPICAL INTERFACE CIRCUIT

Very few external components are required to achieve the stated device performance. Figure 2 shows the typical interface requirements when using the SPT7855 in normal circuit operation. The following sections provide descriptions of the major functions and outline critical performance criteria to consider for achieving the optimal device performance.

## POWER SUPPLIES AND GROUNDING

SPT suggests that both the digital and the analog supply voltages on the SPT7855 be derived from a single analog supply as shown in figure 2. A separate digital supply should be used for all interface circuitry. SPT suggests using this power supply configuration to prevent a possible latch-up condition on powerup.

## OPERATING DESCRIPTION

The general architecture for the CMOS ADC is shown in the block diagram. The design contains 16 identical successive approximation ADC sections, all operating in parallel, a 16-phase clock generator, an 11-bit 16:1 digital output multiplexer, correction logic, and a voltage reference generator that provides common reference levels for each ADC section.

The high sample rate is achieved by using multiple SAR ADC sections in parallel, each of which samples the input signal in sequence. Each ADC uses 16 clock cycles to complete a conversion. The clock cycles are allocated as shown in table II.



Typically, the top side voltage drop for  $V_{RHF}$  to  $V_{RHS}$  will equal:

$$V_{RHF} - V_{RHS} = 2.25 \% \text{ of } (V_{RHF} - V_{RLF}) \text{ (typical),}$$

and the bottom side voltage drop for  $V_{RLS}$  to  $V_{RLF}$  will equal:

$$V_{RLS} - V_{RLF} = 1.9 \% \text{ of } (V_{RHF} - V_{RLF}) \text{ (typical).}$$

Figure 4 shows an example of expected voltage drops for a specific case.  $V_{REF}$  of 4.0 V is applied to  $V_{RHF}$ , and  $V_{RLF}$  is tied to AGND. A 90 mV drop is seen at  $V_{RHS}$  (= 3.91 V), and a 75 mV increase is seen at  $V_{RLS}$  (= 0.075 V).

## ANALOG INPUT

$V_{IN}$  is the analog input. The input voltage range is from  $V_{RLS}$  to  $V_{RHS}$  (typically 4.0 V) and will scale proportionally with respect to the voltage reference. (See voltage reference section.)

The drive requirements for the analog inputs are very minimal when compared to most other converters due to the SPT7855's extremely low input capacitance of only 5 pF and very high input resistance of 50 k $\Omega$ .

The analog input should be protected through a series resistor and diode clamping circuit as shown in figure 5.

**Figure 5 – Recommended Input Protection Circuit**

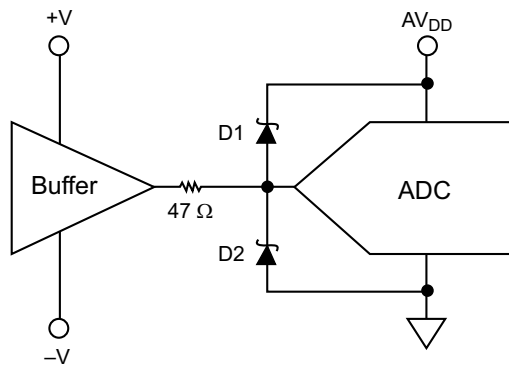

D1 = D2 = Hewlett-Packard HP5712 or equivalent

## CALIBRATION

The SPT7855 uses an auto-calibration scheme to ensure 10-bit accuracy over time and temperature. Gain and offset errors are continually adjusted to 10-bit accuracy during device operation. This process is completely transparent to the user.

Upon powerup, the SPT7855 begins its calibration algorithm. In order to achieve the calibration accuracy required, the offset and gain adjustment step size is a fraction of a 10-bit LSB. Since the calibration algorithm is an oversampling process, a minimum of 10,000 clock cycles are required. This results in a minimum calibration time upon powerup of 400  $\mu$ sec (for a 25 MHz clock). Once calibrated, the SPT7855 remains calibrated over time and temperature.

Since the calibration cycles are initiated on the rising edge of the clock, the clock must be continuously applied for the SPT7855 to remain in calibration.

## INPUT PROTECTION

All I/O pads are protected with an on-chip protection circuit shown in figure 6. This circuit provides ESD robustness to 3.5 kV and prevents latch-up under severe discharge conditions without degrading analog transition times.

**Figure 6 – On-Chip Protection Circuit**

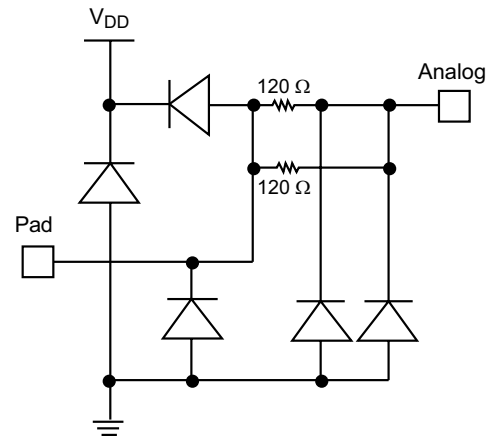

## POWER SUPPLY SEQUENCING CONSIDERATIONS

All logic inputs should be held low until power to the device has settled to the specific tolerances. Avoid power decoupling networks with large time constants that could delay  $V_{DD}$  power to the device.

## CLOCK INPUT

The SPT7855 is driven from a single-ended TTL-input clock. Because the pipelined architecture operates on the rising edge of the clock input, the device can operate over a wide range of input clock duty cycles without degrading the dynamic performance.

## DIGITAL OUTPUTS

The digital outputs (D0–D10) are driven by a separate supply ( $OV_{DD}$ ) ranging from +3 V to +5 V. This feature makes it possible to drive the SPT7855's TTL/CMOS-compatible outputs with the user's logic system supply. The format of the output data (D0–D9) is straight binary. (See table III.) The outputs are latched on the rising edge of CLK. These outputs can be switched into a tri-state mode by bringing  $\overline{EN}$  high.

**Table III – Output Data Information**

ANALOG INPUT	OVERRANGE D10	OUTPUT CODE D9–D0
+F.S. + 1/2 LSB	1	1 1 1 1 1 1 1 1 1 1
+F.S. –1/2 LSB	0	1 1 1 1 1 1 1 1 0
+1/2 F.S.	0	∅∅ ∅∅∅∅ ∅∅∅∅
+1/2 LSB	0	0 0 0 0 0 0 0 0 ∅
0.0 V	0	0 0 0 0 0 0 0 0 0

(∅ indicates the flickering bit between logic 0 and 1.)

## OVERRANGE OUTPUT

The OVERRANGE OUTPUT (D10) is an indication that the analog input signal has exceeded the positive full-scale input voltage by 1 LSB. When this condition occurs, D10 will switch to logic 1. All other data outputs (D0 to D9) will remain at logic 1 as long as D10 remains at logic 1. This feature makes it possible to include the SPT7855 in higher resolution systems.

## EVALUATION BOARD

The EB7855 evaluation board is available to aid designers in demonstrating the full performance of the SPT7855. This board includes a reference circuit, clock driver circuit, output data latches, and an on-board reconstruction of the digital data. An application note describing the operation of this board, as well as information on the testing of the SPT7855, is also available. Contact the factory for price and availability.

## PACKAGE OUTLINES

### 28-Lead SOIC

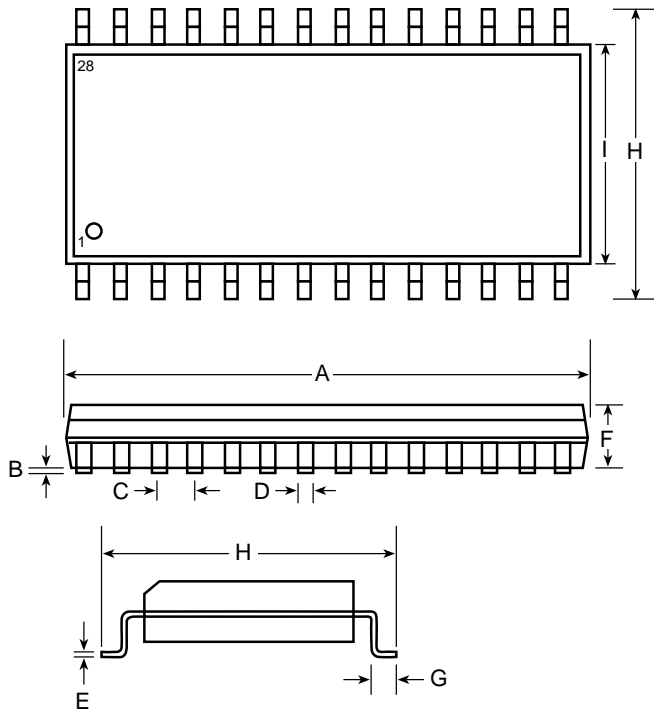

SYMBOL	INCHES		MILLIMETERS	
	MIN	MAX	MIN	MAX
A	0.699	0.709	17.75	18.01
B	0.005	0.011	0.13	0.28
C	0.050 typ		1.27 typ	
D	0.018 typ		0.46 typ	
E	0.0077	0.0083	0.20	0.21
F	0.090	0.096	2.29	2.44
G	0.031	0.039	0.79	0.99
H	0.396	0.416	10.06	10.57
I	0.286	0.292	7.26	7.42

### 32-Lead TQFP

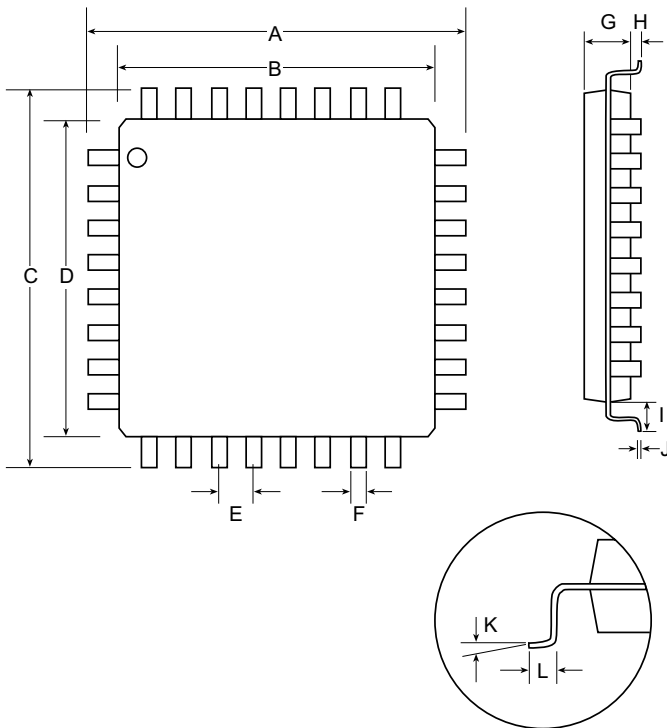

SYMBOL	INCHES		MILLIMETERS	
	MIN	MAX	MIN	MAX
A	0.346	0.362	8.80	9.20
B	0.272	0.280	6.90	7.10
C	0.346	0.362	8.80	9.20
D	0.272	0.280	6.90	7.10
E	0.031 typ		0.80 BSC	
F	0.012	0.016	0.30	0.40
G	0.053	0.057	1.35	1.45
H	0.002	0.006	0.05	0.15
I	0.037	0.041	0.95	1.05
J	0.007		0.17	
K	0°	7°	0°	7°
L	0.020	0.030	0.50	0.75

## PIN ASSIGNMENTS

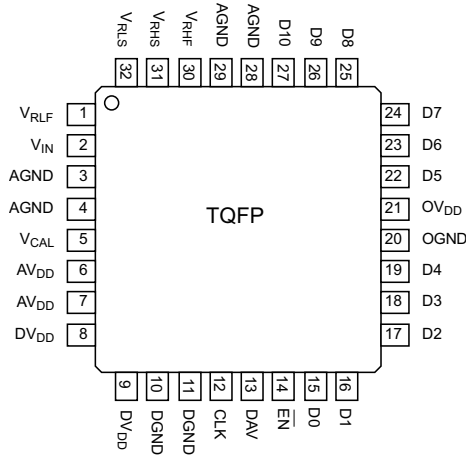
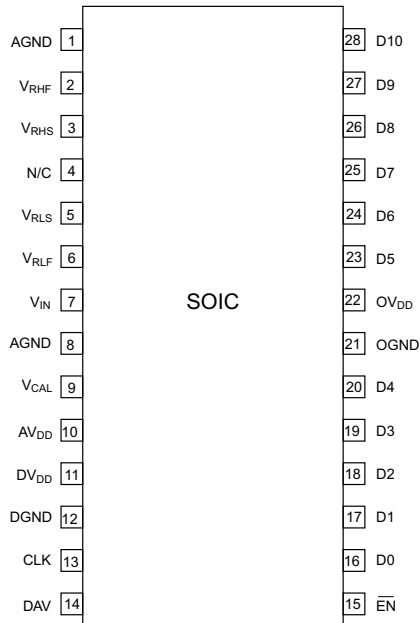

## PIN FUNCTIONS

Name	Function
AGND	Analog Ground
V <sub>RHF</sub>	Reference High Force
V <sub>RHS</sub>	Reference High Sense
V <sub>RLS</sub>	Reference Low Sense
V <sub>RLF</sub>	Reference Low Force
V <sub>CAL</sub>	Calibration Reference
V <sub>IN</sub>	Analog Input
AV <sub>DD</sub>	Analog V <sub>DD</sub>
DV <sub>DD</sub>	Digital V <sub>DD</sub>
DGND	Digital Ground
CLK	Input Clock $f_{CLK} = FS$ (TTL)
EN	Output Enable
D0–9	Tri-State Data Output, (D0=LSB)
D10	Tri-State Output Overrange
DAV	Data Valid Output
OV <sub>DD</sub>	Digital Output Supply
OGND	Digital Output Ground
N/C	No Connect

## ORDERING INFORMATION

PART NUMBER	TEMPERATURE RANGE	PACKAGE TYPE
SPT7855SCS	0 to +70 °C	28L SOIC
SPT7855SCT	0 to +70 °C	32L TQFP
SPT7855SIS	-40 to +85 °C	28L SOIC
SPT7855SIT	-40 to +85 °C	32L TQFP

Signal Processing Technologies, Inc. reserves the right to change products and specifications without notice. Permission is hereby expressly granted to copy this literature for informational purposes only. Copying this material for any other use is strictly prohibited.

**WARNING – LIFE SUPPORT APPLICATIONS POLICY –** SPT products should not be used within Life Support Systems without the specific written consent of SPT. A Life Support System is a product or system intended to support or sustain life which, if it fails, can be reasonably expected to result in significant personal injury or death.

Signal Processing Technologies believes that ultrasonic cleaning of its products may damage the wire bonding, leading to device failure. It is therefore not recommended, and exposure of a device to such a process will void the product warranty.