

74AHC2G241; 74AHCT2G241

Dual buffer/line driver; 3-state

Rev. 01 — 10 March 2004

Product data sheet

1. General description

The 74AHC2G241; 74AHCT2G241 is a high-speed Si-gate CMOS device.

The 74AHC2G241; 74AHCT2G241 is a dual non-inverting buffer/line driver with 3-state outputs. The 3-state outputs are controlled by the output enable inputs $1\overline{OE}$ and 2OE. A HIGH level at pin $1\overline{OE}$ causes output 1Y to assume a high-impedance OFF-state. A LOW level at pin 2OE causes output 2Y to assume a high-impedance OFF-state. Schmitt-trigger action at all inputs makes the circuit highly tolerant for slower input rise and fall times.

2. Features

- Symmetrical output impedance
- High noise immunity
- ESD protection:
 - ◆ HBM EIA/JESD22-A114-A exceeds 2000 V
 - ◆ MM EIA/JESD22-A115-A exceeds 200 V
 - ◆ CDM EIA/JESD22-C101 exceeds 1000 V.
- Low power dissipation
- Balanced propagation delays
- SOT505-2 and SOT765-1 package
- Specified from $-40\text{ }^{\circ}\text{C}$ to $+85\text{ }^{\circ}\text{C}$ and from $-40\text{ }^{\circ}\text{C}$ to $+125\text{ }^{\circ}\text{C}$.

3. Quick reference data

Table 1: Quick reference data

$GND = 0\text{ V}$; $T_{amb} = 25\text{ }^{\circ}\text{C}$; $t_r = t_f \leq 3.0\text{ ns}$.

Symbol	Parameter	Conditions	Min	Typ	Max	Unit
Type 74AHC2G241						
t_{PHL}, t_{PLH}	propagation delay nA to nY	$C_L = 15\text{ pF}$; $V_{CC} = 5\text{ V}$	-	3.4	5.5	ns
t_{PZH}, t_{PZL}	enable time $1\overline{OE}$ to 1Y	$C_L = 15\text{ pF}$; $V_{CC} = 5\text{ V}$	-	3.6	5.1	ns
	enable time 2OE to 2Y	$C_L = 15\text{ pF}$; $V_{CC} = 5\text{ V}$	-	3.6	5.6	ns
t_{PHZ}, t_{PLZ}	disable time $1\overline{OE}$ to 1Y	$C_L = 15\text{ pF}$; $V_{CC} = 5\text{ V}$	-	4.1	6.8	ns
	disable time 2OE to 2Y	$C_L = 15\text{ pF}$; $V_{CC} = 5\text{ V}$	-	4.3	6.8	ns
C_I	input capacitance		-	1.5	10	pF
C_{PD}	power dissipation capacitance	$C_L = 50\text{ pF}$; $f = 1\text{ MHz}$ [1] [2]	-	10	-	pF

PHILIPS

Table 1: Quick reference data ...continued

$GND = 0\text{ V}$; $T_{amb} = 25\text{ }^\circ\text{C}$; $t_r = t_f \leq 3.0\text{ ns}$.

Symbol	Parameter	Conditions	Min	Typ	Max	Unit
Type 74AHCT2G241						
t_{PHL} , t_{PLH}	propagation delay nA to nY	$C_L = 15\text{ pF}$; $V_{CC} = 5\text{ V}$	-	3.4	5.5	ns
t_{PZH} , t_{PZL}	enable time 1OE to 1Y	$C_L = 15\text{ pF}$; $V_{CC} = 5\text{ V}$	-	3.9	5.1	ns
	enable time 2OE to 2Y	$C_L = 15\text{ pF}$; $V_{CC} = 5\text{ V}$	-	3.4	5.6	ns
t_{PHZ} , t_{PLZ}	disable time 1OE to 1Y	$C_L = 15\text{ pF}$; $V_{CC} = 5\text{ V}$	-	4.5	6.8	ns
	disable time 2OE to 2Y	$C_L = 15\text{ pF}$; $V_{CC} = 5\text{ V}$	-	4.0	6.8	ns
C_I	input capacitance		-	1.5	10	pF
C_{PD}	power dissipation capacitance	$C_L = 50\text{ pF}$; $f = 1\text{ MHz}$	[1][2]	10	-	pF

[1] C_{PD} is used to determine the dynamic power dissipation (P_D in μW).

$$P_D = C_{PD} \times V_{CC}^2 \times f_i \times N + \sum(C_L \times V_{CC}^2 \times f_o) \text{ where:}$$

f_i = input frequency in MHz;

f_o = output frequency in MHz;

C_L = output load capacitance in pF;

V_{CC} = supply voltage in Volts;

N = total load switching outputs;

$\sum(C_L \times V_{CC}^2 \times f_o)$ = sum of outputs.

[2] The condition is $V_I = GND$ to V_{CC} .

4. Ordering information

Table 2: Ordering information

Type number	Package			Version
	Temperature range	Name	Description	
74AHC2G241DP	-40 °C to +125 °C	TSSOP8	plastic thin shrink small outline package; 8 leads; body width 3 mm; lead length 0.5 mm	SOT505-2
74AHCT2G241DP	-40 °C to +125 °C	TSSOP8	plastic thin shrink small outline package; 8 leads; body width 3 mm; lead length 0.5 mm	SOT505-2
74AHC2G241DC	-40 °C to +125 °C	VSSOP8	plastic very thin shrink small outline package; 8 leads; body width 2.3 mm	SOT765-1
74AHCT2G241DC	-40 °C to +125 °C	VSSOP8	plastic very thin shrink small outline package; 8 leads; body width 2.3 mm	SOT765-1

5. Marking

Table 3: Marking

Type number	Marking code
74AHC2G241DP	A241
74AHCT2G241DP	C241
74AHC2G241DC	A41
74AHCT2G241DC	C41

6. Functional diagram

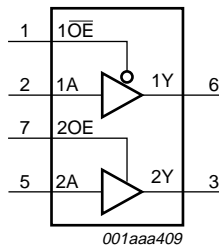

Fig 1. Logic symbol.

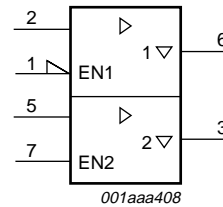

Fig 2. IEC logic symbol.

7. Pinning information

7.1 Pinning

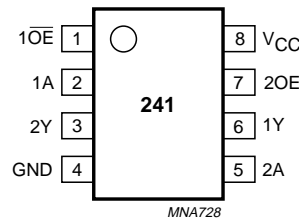

Fig 3. Pin configuration.

7.2 Pin description

Table 4: Pin description

Symbol	Pin	Description
$1\overline{OE}$	1	output enable input (active LOW)
1A	2	data input
2Y	3	data output
GND	4	ground (0 V)
2A	5	data input
1Y	6	data output
2OE	7	output enable input (active HIGH)
V_{CC}	8	supply voltage

8. Functional description

Table 5: Function table [1]

Input		Output	Input		Output
1OE	1A	1Y	2OE	2A	2Y
L	L	L	H	L	L
L	H	H	H	H	H
H	X	Z	L	X	Z

- [1] H = HIGH voltage level;
L = LOW voltage level;
X = don't care;
Z = high-impedance OFF-state.

9. Limiting values

Table 6: Limiting values

In accordance with the Absolute Maximum Rating System (IEC 60134). Voltages are referenced to GND (ground = 0 V).

Symbol	Parameter	Conditions	Min	Max	Unit
V_{CC}	supply voltage		-0.5	+7.0	V
V_I	input voltage		-0.5	+7.0	V
I_{IK}	input diode current	$V_I < -0.5$ V	-	-20	mA
I_{OK}	output diode current	$V_O < -0.5$ V or $V_O > V_{CC} + 0.5$ V	[1]	± 20	mA
I_O	output source or sink current	$V_O = -0.5$ V to $(V_{CC} + 0.5$ V)	-	± 25	mA
I_{CC}, I_{GND}	V_{CC} or GND current		-	± 75	mA
T_{stg}	storage temperature		-65	+150	°C
P_{tot}	power dissipation	$T_{amb} = -40$ °C to +125 °C	-	250	mW

- [1] The input and output voltage ratings may be exceeded if the input and output current ratings are observed.

10. Recommended operating conditions

Table 7: Recommended operating conditions

Symbol	Parameter	Conditions	Min.	Typ.	Max.	Unit
Type 74AHC2G241						
V_{CC}	supply voltage		2.0	5.0	5.5	V
V_I	input voltage		0	-	5.5	V
V_O	output voltage		0	-	V_{CC}	V
T_{amb}	operating ambient temperature	see Section 11 and Section 12	-40	+25	+125	°C
t_r, t_f	input rise and fall times	$V_{CC} = 3.3$ V \pm 0.3 V	-	-	100	ns/V
		$V_{CC} = 5$ V \pm 0.5 V	-	-	20	ns/V
Type 74AHCT2G241						
V_{CC}	supply voltage		4.5	5.0	5.5	V

Table 7: Recommended operating conditions ...continued

Symbol	Parameter	Conditions	Min.	Typ.	Max.	Unit
V_I	input voltage		0	-	5.5	V
V_O	output voltage		0	-	V_{CC}	V
T_{amb}	operating ambient temperature	see Section 11 and Section 12	-40	+25	+125	°C
t_r, t_f	input rise and fall times	$V_{CC} = 5\text{ V} \pm 0.5\text{ V}$	-	-	20	ns/V

11. Static characteristics

Table 8: Static characteristics type 74AHC2G241

At recommended operating conditions; voltages are referenced to GND (ground = 0 V).

Symbol	Parameter	Conditions	Min	Typ	Max	Unit
$T_{amb} = 25\text{ °C}$						
V_{IH}	HIGH-level input voltage	$V_{CC} = 2.0\text{ V}$	1.5	-	-	V
		$V_{CC} = 3.0\text{ V}$	2.1	-	-	V
		$V_{CC} = 5.5\text{ V}$	3.85	-	-	V
V_{IL}	LOW-level input voltage	$V_{CC} = 2.0\text{ V}$	-	-	0.5	V
		$V_{CC} = 3.0\text{ V}$	-	-	0.9	V
		$V_{CC} = 5.5\text{ V}$	-	-	1.65	V
V_{OH}	HIGH-level output voltage	$V_I = V_{IH}$ or V_{IL}				
		$I_O = -50\text{ }\mu\text{A}; V_{CC} = 2.0\text{ V}$	1.9	2.0	-	V
		$I_O = -50\text{ }\mu\text{A}; V_{CC} = 3.0\text{ V}$	2.9	3.0	-	V
		$I_O = -50\text{ }\mu\text{A}; V_{CC} = 4.5\text{ V}$	4.4	4.5	-	V
		$I_O = -4.0\text{ mA}; V_{CC} = 3.0\text{ V}$	2.58	-	-	V
		$I_O = -8.0\text{ mA}; V_{CC} = 4.5\text{ V}$	3.94	-	-	V
V_{OL}	LOW-level output voltage	$V_I = V_{IH}$ or V_{IL}				
		$I_O = 50\text{ }\mu\text{A}; V_{CC} = 2.0\text{ V}$	-	0	0.1	V
		$I_O = 50\text{ }\mu\text{A}; V_{CC} = 3.0\text{ V}$	-	0	0.1	V
		$I_O = 50\text{ }\mu\text{A}; V_{CC} = 4.5\text{ V}$	-	0	0.1	V
		$I_O = 4.0\text{ mA}; V_{CC} = 3.0\text{ V}$	-	-	0.36	V
		$I_O = 8.0\text{ mA}; V_{CC} = 4.5\text{ V}$	-	-	0.36	V
I_{OZ}	3-state OFF-state current	$V_I = V_{CC}$ or GND; $V_{CC} = 5.5\text{ V}$	-	-	0.25	μA
I_{LI}	input leakage current	$V_I = V_{CC}$ or GND; $V_{CC} = 5.5\text{ V}$	-	-	0.1	μA
I_{CC}	quiescent supply current	$V_I = V_{CC}$ or GND; $I_O = 0\text{ A}; V_{CC} = 5.5\text{ V}$	-	-	1.0	μA
C_I	input capacitance		-	1.5	10	pF
$T_{amb} = -40\text{ °C to }+85\text{ °C}$						
V_{IH}	HIGH-level input voltage	$V_{CC} = 2.0\text{ V}$	1.5	-	-	V
		$V_{CC} = 3.0\text{ V}$	2.1	-	-	V
		$V_{CC} = 5.5\text{ V}$	3.85	-	-	V

Table 8: Static characteristics type 74AHC2G241 ...continued

At recommended operating conditions; voltages are referenced to GND (ground = 0 V).

Symbol	Parameter	Conditions	Min	Typ	Max	Unit
V _{IL}	LOW-level input voltage	V _{CC} = 2.0 V	-	-	0.5	V
		V _{CC} = 3.0 V	-	-	0.9	V
		V _{CC} = 5.5 V	-	-	1.65	V
V _{OH}	HIGH-level output voltage	V _I = V _{IH} or V _{IL}				
		I _O = -50 µA; V _{CC} = 2.0 V	1.9	-	-	V
		I _O = -50 µA; V _{CC} = 3.0 V	2.9	-	-	V
		I _O = -50 µA; V _{CC} = 4.5 V	4.4	-	-	V
		I _O = -4.0 mA; V _{CC} = 3.0 V	2.48	-	-	V
		I _O = -8.0 mA; V _{CC} = 4.5 V	3.8	-	-	V
V _{OL}	LOW-level output voltage	V _I = V _{IH} or V _{IL}				
		I _O = 50 µA; V _{CC} = 2.0 V	-	-	0.1	V
		I _O = 50 µA; V _{CC} = 3.0 V	-	-	0.1	V
		I _O = 50 µA; V _{CC} = 4.5 V	-	-	0.1	V
		I _O = 4.0 mA; V _{CC} = 3.0 V	-	-	0.44	V
		I _O = 8.0 mA; V _{CC} = 4.5 V	-	-	0.44	V
I _{OZ}	3-state OFF-state current	V _I = V _{CC} or GND; V _{CC} = 5.5 V	-	-	2.5	µA
I _{LI}	input leakage current	V _I = V _{CC} or GND; V _{CC} = 5.5 V	-	-	1.0	µA
I _{CC}	quiescent supply current	V _I = V _{CC} or GND; I _O = 0 A; V _{CC} = 5.5 V	-	-	10	µA
C _I	input capacitance		-	-	10	pF
T_{amb} = -40 °C to +125 °C						
V _{IH}	HIGH-level input voltage	V _{CC} = 2.0 V	1.5	-	-	V
		V _{CC} = 3.0 V	2.1	-	-	V
		V _{CC} = 5.5 V	3.85	-	-	V
V _{IL}	LOW-level input voltage	V _{CC} = 2.0 V	-	-	0.5	V
		V _{CC} = 3.0 V	-	-	0.9	V
		V _{CC} = 5.5 V	-	-	1.65	V
V _{OH}	HIGH-level output voltage	V _I = V _{IH} or V _{IL}				
		I _O = -50 µA; V _{CC} = 2.0 V	1.9	-	-	V
		I _O = -50 µA; V _{CC} = 3.0 V	2.9	-	-	V
		I _O = -50 µA; V _{CC} = 4.5 V	4.4	-	-	V
		I _O = -4.0 mA; V _{CC} = 3.0 V	2.40	-	-	V
		I _O = -8.0 mA; V _{CC} = 4.5 V	3.70	-	-	V
V _{OL}	LOW-level output voltage	V _I = V _{IH} or V _{IL}				
		I _O = 50 µA; V _{CC} = 2.0 V	-	-	0.1	V
		I _O = 50 µA; V _{CC} = 3.0 V	-	-	0.1	V
		I _O = 50 µA; V _{CC} = 4.5 V	-	-	0.1	V
		I _O = 4.0 mA; V _{CC} = 3.0 V	-	-	0.55	V
		I _O = 8.0 mA; V _{CC} = 4.5 V	-	-	0.55	V

Table 8: Static characteristics type 74AHC2G241 ...continued

At recommended operating conditions; voltages are referenced to GND (ground = 0 V).

Symbol	Parameter	Conditions	Min	Typ	Max	Unit
I_{OZ}	3-state OFF-state current	$V_I = V_{CC}$ or GND; $V_{CC} = 5.5$ V	-	-	10	μ A
I_{LI}	input leakage current	$V_I = V_{CC}$ or GND; $V_{CC} = 5.5$ V	-	-	2.0	μ A
I_{CC}	quiescent supply current	$V_I = V_{CC}$ or GND; $I_O = 0$ A; $V_{CC} = 5.5$ V	-	-	40	μ A
C_I	input capacitance		-	-	10	pF

Table 9: Static characteristics type 74AHCT2G241

At recommended operating conditions; voltages are referenced to GND (ground = 0 V).

Symbol	Parameter	Conditions	Min	Typ	Max	Unit
$T_{amb} = 25$ °C						
V_{IH}	HIGH-level input voltage	$V_{CC} = 4.5$ V to 5.5 V	2.0	-	-	V
V_{IL}	LOW-level input voltage	$V_{CC} = 4.5$ V to 5.5 V	-	-	0.8	V
V_{OH}	HIGH-level output voltage	$V_I = V_{IH}$ or V_{IL}				
		$I_O = -50$ μ A; $V_{CC} = 4.5$ V	4.4	4.5	-	V
		$I_O = -8.0$ mA; $V_{CC} = 4.5$ V	3.94	-	-	V
V_{OL}	LOW-level output voltage	$V_I = V_{IH}$ or V_{IL}				
		$I_O = 50$ μ A; $V_{CC} = 4.5$ V	-	0	0.1	V
		$I_O = 8.0$ mA; $V_{CC} = 4.5$ V	-	-	0.36	V
I_{OZ}	3-state OFF-state current	$V_I = V_{CC}$ or GND; $V_{CC} = 5.5$ V	-	-	0.25	μ A
I_{LI}	input leakage current	$V_I = V_{IH}$ or V_{IL} ; $V_{CC} = 5.5$ V	-	-	0.1	μ A
I_{CC}	quiescent supply current	$V_I = V_{CC}$ or GND; $I_O = 0$ A; $V_{CC} = 5.5$ V	-	-	1.0	μ A
ΔI_{CC}	additional quiescent supply current per input pin	$V_I = 3.4$ V; other inputs at V_{CC} or GND; $I_O = 0$ A; $V_{CC} = 5.5$ V	-	-	1.35	mA
C_I	input capacitance		-	1.5	10	pF
$T_{amb} = -40$ °C to +85 °C						
V_{IH}	HIGH-level input voltage	$V_{CC} = 4.5$ V to 5.5 V	2.0	-	-	V
V_{IL}	LOW-level input voltage	$V_{CC} = 4.5$ V to 5.5 V	-	-	0.8	V
V_{OH}	HIGH-level output voltage	$V_I = V_{IH}$ or V_{IL}				
		$I_O = -50$ μ A; $V_{CC} = 4.5$ V	4.4	-	-	V
		$I_O = -8.0$ mA; $V_{CC} = 4.5$ V	3.8	-	-	V
V_{OL}	LOW-level output voltage	$V_I = V_{IH}$ or V_{IL}				
		$I_O = 50$ μ A; $V_{CC} = 4.5$ V	-	-	0.1	V
		$I_O = 8.0$ mA; $V_{CC} = 4.5$ V	-	-	0.44	V
I_{OZ}	3-state OFF-state current	$V_I = V_{CC}$ or GND; $V_{CC} = 5.5$ V	-	-	2.5	μ A

Table 9: Static characteristics type 74AHCT2G241 ...continued

At recommended operating conditions; voltages are referenced to GND (ground = 0 V).

Symbol	Parameter	Conditions	Min	Typ	Max	Unit
I_{LI}	input leakage current	$V_I = V_{IH}$ or V_{IL} ; $V_{CC} = 5.5$ V	-	-	1.0	μ A
I_{CC}	quiescent supply current	$V_I = V_{CC}$ or GND; $I_O = 0$ A; $V_{CC} = 5.5$ V	-	-	10	μ A
ΔI_{CC}	additional quiescent supply current per input pin	$V_I = 3.4$ V; other inputs at V_{CC} or GND; $I_O = 0$ A; $V_{CC} = 5.5$ V	-	-	1.5	mA
C_I	input capacitance		-	-	10	pF
$T_{amb} = -40$ °C to $+125$ °C						
V_{IH}	HIGH-level input voltage	$V_{CC} = 4.5$ V to 5.5 V	2.0	-	-	V
V_{IL}	LOW-level input voltage	$V_{CC} = 4.5$ V to 5.5 V	-	-	0.8	V
V_{OH}	HIGH-level output voltage	$V_I = V_{IH}$ or V_{IL}				
		$I_O = -50$ μ A; $V_{CC} = 4.5$ V	4.4	-	-	V
		$I_O = -8.0$ mA; $V_{CC} = 4.5$ V	3.70	-	-	V
V_{OL}	LOW-level output voltage	$V_I = V_{IH}$ or V_{IL}				
		$I_O = 50$ μ A; $V_{CC} = 4.5$ V	-	-	0.1	V
		$I_O = 8.0$ mA; $V_{CC} = 4.5$ V	-	-	0.55	V
I_{OZ}	3-state OFF-state current	$V_I = V_{CC}$ or GND; $V_{CC} = 5.5$ V	-	-	10	μ A
I_{LI}	input leakage current	$V_I = V_{IH}$ or V_{IL} ; $V_{CC} = 5.5$ V	-	-	2.0	μ A
I_{CC}	quiescent supply current	$V_I = V_{CC}$ or GND; $I_O = 0$ A; $V_{CC} = 5.5$ V	-	-	40	μ A
ΔI_{CC}	additional quiescent supply current per input pin	$V_I = 3.4$ V; other inputs at V_{CC} or GND; $I_O = 0$ A; $V_{CC} = 5.5$ V	-	-	1.5	mA
C_I	input capacitance		-	-	10	pF

12. Dynamic characteristics

Table 10: Dynamic characteristics type 74AHC2G241GND = 0 V; $t_r = t_f \leq 3.0$ ns; see [Figure 7](#).

Symbol	Parameter	Conditions	Min	Typ	Max	Unit	
$T_{amb} = 25$ °C							
t_{PHL} , t_{PLH}	propagation delay nA to nY	see Figure 4					
		$V_{CC} = 3.0$ V to 3.6 V; $C_L = 15$ pF	[1]	-	4.7	8.0	ns
		$V_{CC} = 4.5$ V to 5.5 V; $C_L = 15$ pF	[2]	-	3.4	5.5	ns
		$V_{CC} = 3.0$ V to 3.6 V; $C_L = 50$ pF	[1]	-	6.6	11.5	ns
		$V_{CC} = 4.5$ V to 5.5 V; $C_L = 50$ pF	[2]	-	4.7	7.5	ns

Table 10: Dynamic characteristics type 74AHC2G241 ...continued

GND = 0 V; $t_r = t_f \leq 3.0$ ns; see [Figure 7](#).

Symbol	Parameter	Conditions	Min	Typ	Max	Unit
t_{PZH} , t_{PZL}	enable time $\overline{1OE}$ to 1Y	see Figure 5				
		$V_{CC} = 3.0$ V to 3.6 V; $C_L = 15$ pF	[1] -	5.0	8.0	ns
		$V_{CC} = 4.5$ V to 5.5 V; $C_L = 15$ pF	[2] -	3.6	5.1	ns
		$V_{CC} = 3.0$ V to 3.6 V; $C_L = 50$ pF	[1] -	6.9	11.5	ns
	enable time 2OE to 2Y	see Figure 6				
		$V_{CC} = 3.0$ V to 3.6 V; $C_L = 15$ pF	[1] -	4.9	8.0	ns
		$V_{CC} = 4.5$ V to 5.5 V; $C_L = 15$ pF	[2] -	3.6	5.6	ns
		$V_{CC} = 3.0$ V to 3.6 V; $C_L = 50$ pF	[1] -	7.0	11.5	ns
t_{PHZ} , t_{PLZ}	disable time $\overline{1OE}$ to 1Y	see Figure 5				
		$V_{CC} = 3.0$ V to 3.6 V; $C_L = 15$ pF	[1] -	6.0	9.7	ns
		$V_{CC} = 4.5$ V to 5.5 V; $C_L = 15$ pF	[2] -	4.1	6.8	ns
		$V_{CC} = 3.0$ V to 3.6 V; $C_L = 50$ pF	[1] -	8.3	13.2	ns
	disable time 2OE to 2Y	see Figure 6				
		$V_{CC} = 3.0$ V to 3.6 V; $C_L = 15$ pF	[1] -	6.3	9.7	ns
		$V_{CC} = 4.5$ V to 5.5 V; $C_L = 15$ pF	[2] -	4.3	6.8	ns
		$V_{CC} = 3.0$ V to 3.6 V; $C_L = 50$ pF	[1] -	9.0	13.2	ns
t_{PHL} , t_{PLH}	propagation delay nA to nY	see Figure 4				
		$V_{CC} = 3.0$ V to 3.6 V; $C_L = 15$ pF	1.0	-	9.5	ns
		$V_{CC} = 4.5$ V to 5.5 V; $C_L = 15$ pF	1.0	-	6.5	ns
		$V_{CC} = 3.0$ V to 3.6 V; $C_L = 50$ pF	1.0	-	13.0	ns
	enable time $\overline{1OE}$ to 1Y	see Figure 5				
		$V_{CC} = 3.0$ V to 3.6 V; $C_L = 15$ pF	1.0	-	9.5	ns
		$V_{CC} = 4.5$ V to 5.5 V; $C_L = 15$ pF	1.0	-	6.0	ns
		$V_{CC} = 3.0$ V to 3.6 V; $C_L = 50$ pF	1.0	-	13.0	ns
enable time 2OE to 2Y	see Figure 6					
	$V_{CC} = 3.0$ V to 3.6 V; $C_L = 15$ pF	1.0	-	9.5	ns	
	$V_{CC} = 4.5$ V to 5.5 V; $C_L = 15$ pF	1.0	-	6.3	ns	
	$V_{CC} = 3.0$ V to 3.6 V; $C_L = 50$ pF	1.0	-	13.0	ns	

 $T_{amb} = -40$ °C to +85 °C

Table 10: Dynamic characteristics type 74AHC2G241 ...continued

GND = 0 V; $t_r = t_f \leq 3.0$ ns; see [Figure 7](#).

Symbol	Parameter	Conditions	Min	Typ	Max	Unit
t_{PHZ}, t_{PLZ}	disable time $\overline{1OE}$ to 1Y	see Figure 5				
		$V_{CC} = 3.0$ V to 3.6 V; $C_L = 15$ pF	1.0	-	11.5	ns
		$V_{CC} = 4.5$ V to 5.5 V; $C_L = 15$ pF	1.0	-	8.0	ns
		$V_{CC} = 3.0$ V to 3.6 V; $C_L = 50$ pF	1.0	-	15.0	ns
	disable time 2OE to 2Y	see Figure 6				
		$V_{CC} = 3.0$ V to 3.6 V; $C_L = 15$ pF	1.0	-	11.5	ns
		$V_{CC} = 4.5$ V to 5.5 V; $C_L = 15$ pF	1.0	-	8.0	ns
		$V_{CC} = 3.0$ V to 3.6 V; $C_L = 50$ pF	1.0	-	15.0	ns
$T_{amb} = -40$ °C to $+125$ °C						
t_{PHL}, t_{PLH}	propagation delay nA to nY	see Figure 4				
		$V_{CC} = 3.0$ V to 3.6 V; $C_L = 15$ pF	1.0	-	11.5	ns
		$V_{CC} = 4.5$ V to 5.5 V; $C_L = 15$ pF	1.0	-	7.0	ns
		$V_{CC} = 3.0$ V to 3.6 V; $C_L = 50$ pF	1.0	-	14.5	ns
t_{PZH}, t_{PZL}	enable time $\overline{1OE}$ to 1Y	see Figure 5				
		$V_{CC} = 3.0$ V to 3.6 V; $C_L = 15$ pF	1.0	-	11.5	ns
		$V_{CC} = 4.5$ V to 5.5 V; $C_L = 15$ pF	1.0	-	6.5	ns
		$V_{CC} = 3.0$ V to 3.6 V; $C_L = 50$ pF	1.0	-	14.5	ns
	enable time 2OE to 2Y	see Figure 6				
		$V_{CC} = 3.0$ V to 3.6 V; $C_L = 15$ pF	1.0	-	10.0	ns
		$V_{CC} = 4.5$ V to 5.5 V; $C_L = 15$ pF	1.0	-	7.0	ns
		$V_{CC} = 3.0$ V to 3.6 V; $C_L = 50$ pF	1.0	-	14.5	ns
t_{PHZ}, t_{PLZ}	disable time $\overline{1OE}$ to 1Y	see Figure 5				
		$V_{CC} = 3.0$ V to 3.6 V; $C_L = 15$ pF	1.0	-	12.5	ns
		$V_{CC} = 4.5$ V to 5.5 V; $C_L = 15$ pF	1.0	-	8.5	ns
		$V_{CC} = 3.0$ V to 3.6 V; $C_L = 50$ pF	1.0	-	16.5	ns
	disable time 2OE to 2Y	see Figure 6				
		$V_{CC} = 3.0$ V to 3.6 V; $C_L = 15$ pF	1.0	-	12.5	ns
		$V_{CC} = 4.5$ V to 5.5 V; $C_L = 15$ pF	1.0	-	8.5	ns
		$V_{CC} = 3.0$ V to 3.6 V; $C_L = 50$ pF	1.0	-	16.5	ns
$V_{CC} = 4.5$ V to 5.5 V; $C_L = 50$ pF	1.0	-	11.0	ns		

[1] Typical values are measured at $V_{CC} = 3.3$ V.[2] Typical values are measured at $V_{CC} = 5.0$ V.

Table 11: Dynamic characteristics type 74AHCT2G241

GND = 0 V; $t_r = t_f \leq 3.0$ ns; see [Figure 7](#)

Symbol	Parameter	Conditions	Min	Typ	Max	Unit
$T_{amb} = 25$ °C [1]						
t_{PHL} , t_{PLH}	propagation delay nA to nY	see Figure 4 ; $V_{CC} = 4.5$ V to 5.5 V				
		$C_L = 15$ pF	-	3.4	5.5	ns
		$C_L = 50$ pF	-	4.7	7.5	ns
t_{PZH} , t_{PZL}	enable time $\overline{1OE}$ to 1Y	see Figure 5 ; $V_{CC} = 4.5$ V to 5.5 V				
		$C_L = 15$ pF	-	3.9	5.1	ns
		$C_L = 50$ pF	-	5.1	7.5	ns
	enable time 2OE to 2Y	see Figure 6 ; $V_{CC} = 4.5$ V to 5.5 V				
		$C_L = 15$ pF	-	3.4	5.6	ns
		$C_L = 50$ pF	-	4.8	7.5	ns
t_{PHZ} , t_{PLZ}	disable time $\overline{1OE}$ to 1Y	see Figure 5 ; $V_{CC} = 4.5$ V to 5.5 V				
		$C_L = 15$ pF	-	4.5	6.8	ns
		$C_L = 50$ pF	-	6.1	8.8	ns
	disable time 2OE to 2Y	see Figure 6 ; $V_{CC} = 4.5$ V to 5.5 V				
		$C_L = 15$ pF	-	4.0	6.8	ns
		$C_L = 50$ pF	-	5.7	8.8	ns
$T_{amb} = -40$ °C to +85 °C						
t_{PHL} , t_{PLH}	propagation delay nA to nY	see Figure 4 ; $V_{CC} = 4.5$ V to 5.5 V				
		$C_L = 15$ pF	1.0	-	6.5	ns
		$C_L = 50$ pF	1.0	-	8.5	ns
t_{PZH} , t_{PZL}	enable time $\overline{1OE}$ to 1Y	see Figure 5 ; $V_{CC} = 4.5$ V to 5.5 V				
		$C_L = 15$ pF	1.0	-	6.0	ns
		$C_L = 50$ pF	1.0	-	8.5	ns
	enable time 2OE to 2Y	see Figure 6 ; $V_{CC} = 4.5$ V to 5.5 V				
		$C_L = 15$ pF	1.0	-	6.3	ns
		$C_L = 50$ pF	1.0	-	9.0	ns
t_{PHZ} , t_{PLZ}	disable time $\overline{1OE}$ to 1Y	see Figure 5 ; $V_{CC} = 4.5$ V to 5.5 V				
		$C_L = 15$ pF	1.0	-	8.0	ns
		$C_L = 50$ pF	1.0	-	10.0	ns
	disable time 2OE to 2Y	see Figure 6 ; $V_{CC} = 4.5$ V to 5.5 V				
		$C_L = 15$ pF	1.0	-	8.0	ns
		$C_L = 50$ pF	1.0	-	10.0	ns
$T_{amb} = -40$ °C to +125 °C						
t_{PHL} , t_{PLH}	propagation delay nA to nY	see Figure 4 ; $V_{CC} = 4.5$ V to 5.5 V				
		$C_L = 15$ pF	1.0	-	7.0	ns
		$C_L = 50$ pF	1.0	-	9.5	ns

Table 11: Dynamic characteristics type 74AHCT2G241 ...continued

$GND = 0\text{ V}$; $t_r = t_f \leq 3.0\text{ ns}$; see [Figure 7](#)

Symbol	Parameter	Conditions	Min	Typ	Max	Unit
t_{PZH} , t_{PZL}	enable time $\overline{1OE}$ to 1Y	see Figure 5 ; $V_{CC} = 4.5\text{ V}$ to 5.5 V				
		$C_L = 15\text{ pF}$	1.0	-	6.5	ns
		$C_L = 50\text{ pF}$	1.0	-	9.5	ns
	enable time 2OE to 2Y	see Figure 6 ; $V_{CC} = 4.5\text{ V}$ to 5.5 V				
		$C_L = 15\text{ pF}$	1.0	-	6.5	ns
		$C_L = 50\text{ pF}$	1.0	-	9.5	ns
t_{PHZ} , t_{PLZ}	disable time $\overline{1OE}$ to 1Y	see Figure 5 ; $V_{CC} = 4.5\text{ V}$ to 5.5 V				
		$C_L = 15\text{ pF}$	1.0	-	8.5	ns
		$C_L = 50\text{ pF}$	1.0	-	11.0	ns
	disable time 2OE to 2Y	see Figure 6 ; $V_{CC} = 4.5\text{ V}$ to 5.5 V				
		$C_L = 15\text{ pF}$	1.0	-	8.5	ns
		$C_L = 50\text{ pF}$	1.0	-	11.0	ns

[1] All typical values are measured at $V_{CC} = 5.0\text{ V}$.

13. Waveforms

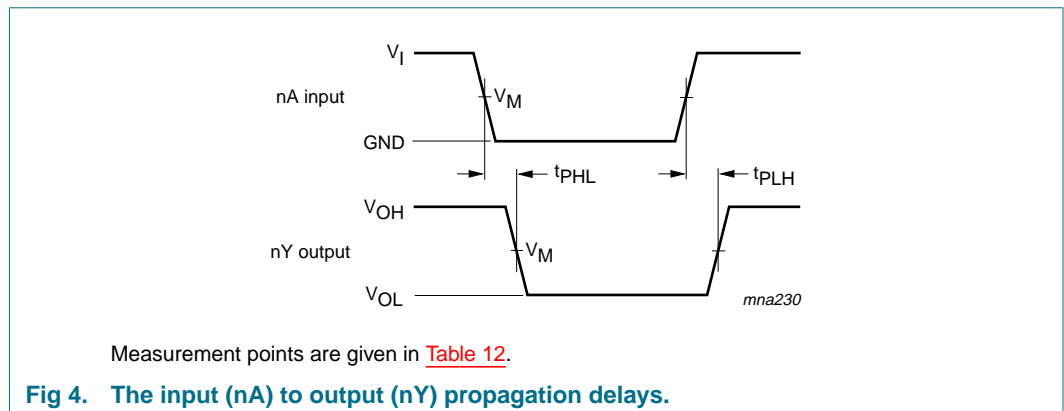
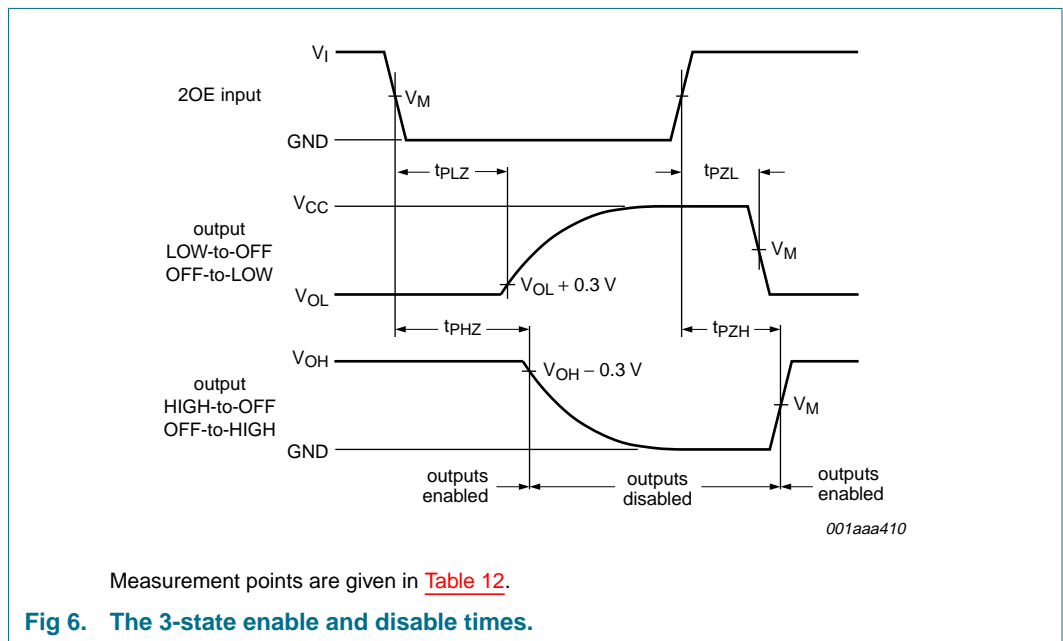
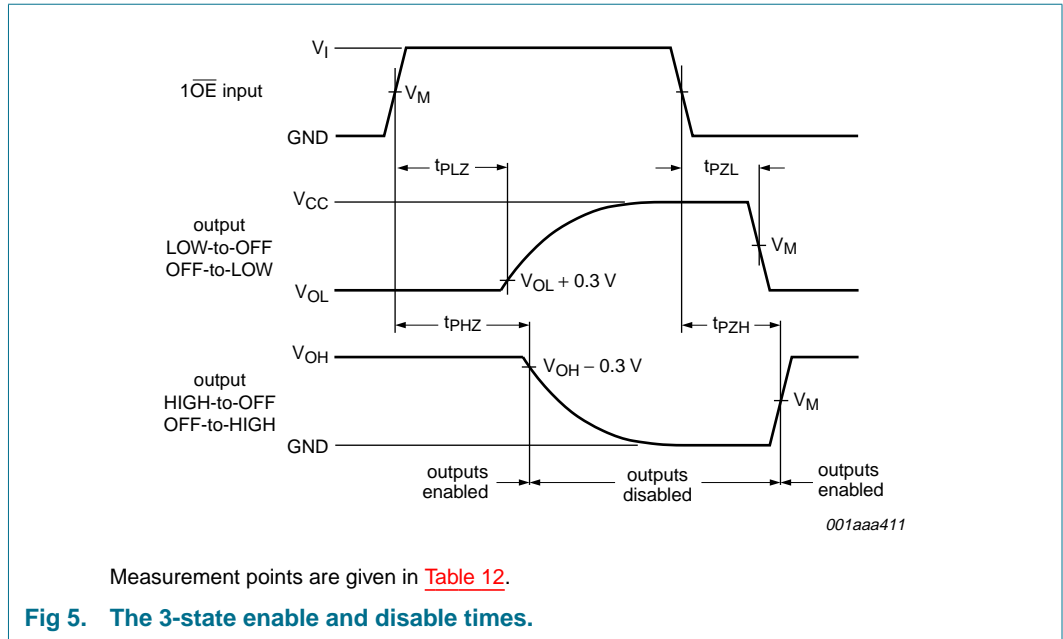

Table 12: Measurement points

Type	V_I input requirements	V_M input	V_M output
74AHC2G241	GND to V_{CC}	$50\% V_{CC}$	$50\% V_{CC}$
74AHCT2G241	GND to 3.0 V	1.5 V	$50\% V_{CC}$



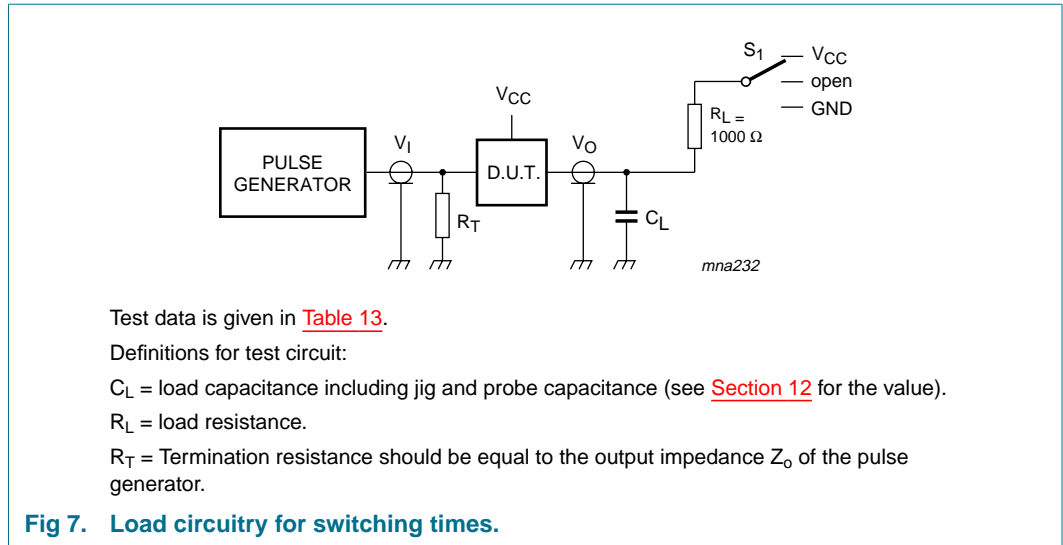

Table 13: Test data

Test	S_1
t_{PLH} , t_{PHL}	open
t_{PLZ} , t_{PZL}	V_{CC}
t_{PHZ} , t_{PZH}	GND

14. Package outline

TSSOP8: plastic thin shrink small outline package; 8 leads; body width 3 mm; lead length 0.5 mm SOT505-2

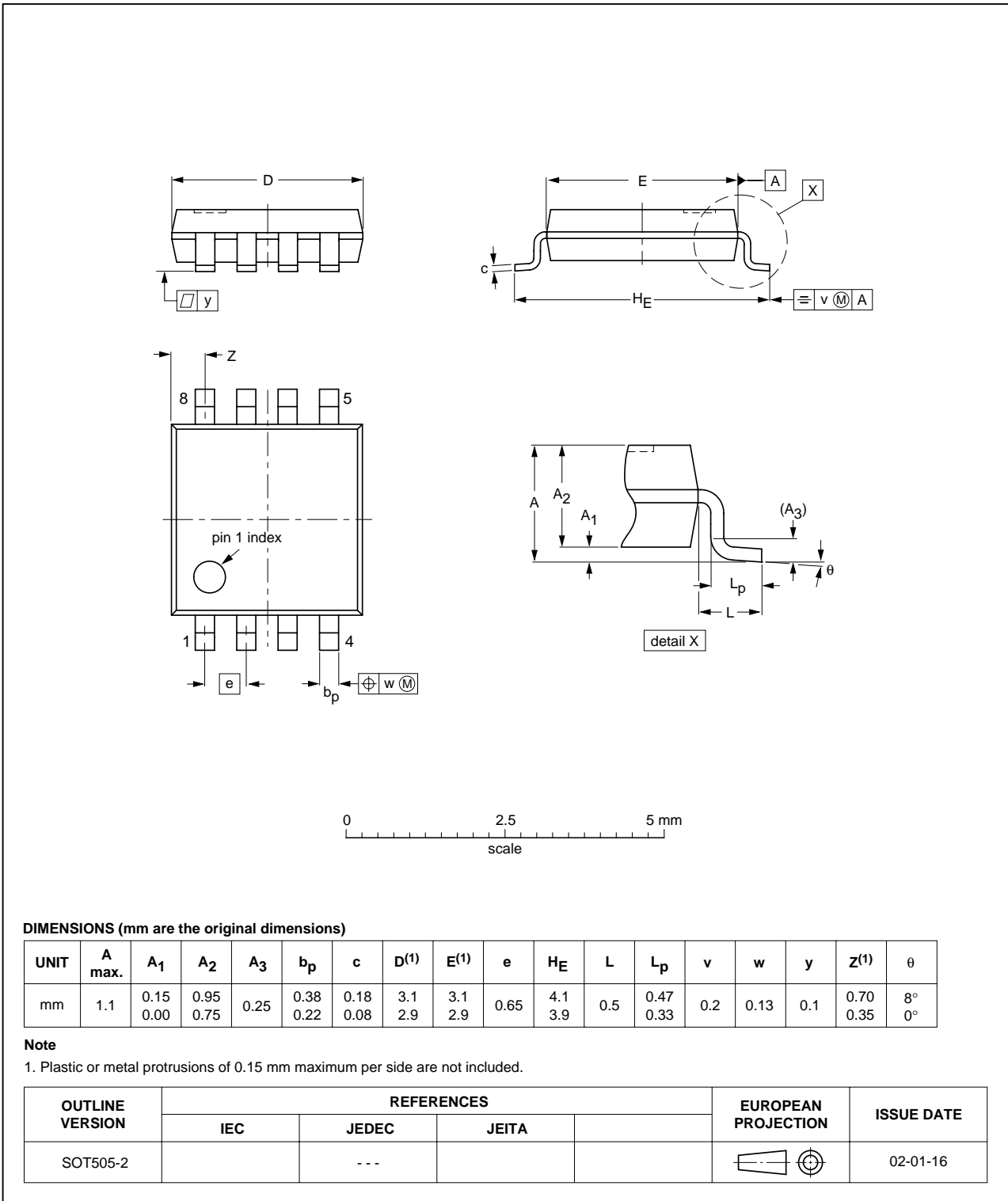

Fig 8. Package outline TSSOP8.

VSSOP8: plastic very thin shrink small outline package; 8 leads; body width 2.3 mm

SOT765-1

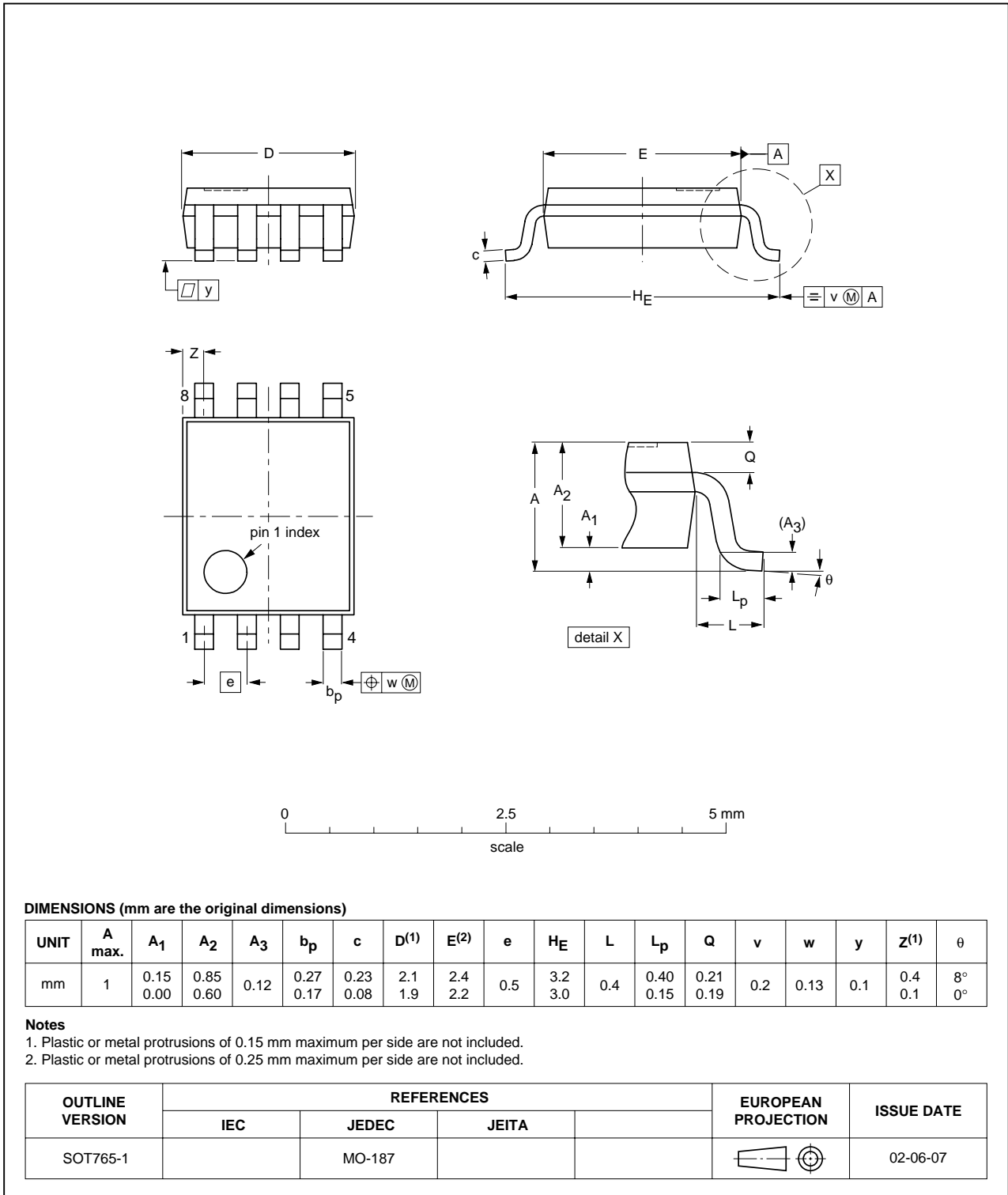

Fig 9. Package outline VSSOP8.

15. Revision history

Table 14: Revision history

Document ID	Release date	Data sheet status	Change notice	Order number	Supersedes
74AHC_AHCT2G241_1	20040310	Product data	-	9397 750 12887	-

16. Data sheet status

Level	Data sheet status ^[1]	Product status ^[2] ^[3]	Definition
I	Objective data	Development	This data sheet contains data from the objective specification for product development. Philips Semiconductors reserves the right to change the specification in any manner without notice.
II	Preliminary data	Qualification	This data sheet contains data from the preliminary specification. Supplementary data will be published at a later date. Philips Semiconductors reserves the right to change the specification without notice, in order to improve the design and supply the best possible product.
III	Product data	Production	This data sheet contains data from the product specification. Philips Semiconductors reserves the right to make changes at any time in order to improve the design, manufacturing and supply. Relevant changes will be communicated via a Customer Product/Process Change Notification (CPCN).

[1] Please consult the most recently issued data sheet before initiating or completing a design.

[2] The product status of the device(s) described in this data sheet may have changed since this data sheet was published. The latest information is available on the Internet at URL <http://www.semiconductors.philips.com>.

[3] For data sheets describing multiple type numbers, the highest-level product status determines the data sheet status.

17. Definitions

Short-form specification — The data in a short-form specification is extracted from a full data sheet with the same type number and title. For detailed information see the relevant data sheet or data handbook.

Limiting values definition — Limiting values given are in accordance with the Absolute Maximum Rating System (IEC 60134). Stress above one or more of the limiting values may cause permanent damage to the device. These are stress ratings only and operation of the device at these or at any other conditions above those given in the Characteristics sections of the specification is not implied. Exposure to limiting values for extended periods may affect device reliability.

Application information — Applications that are described herein for any of these products are for illustrative purposes only. Philips Semiconductors make no representation or warranty that such applications will be suitable for the specified use without further testing or modification.

18. Disclaimers

Life support — These products are not designed for use in life support appliances, devices, or systems where malfunction of these products can reasonably be expected to result in personal injury. Philips Semiconductors customers using or selling these products for use in such applications do so at their own risk and agree to fully indemnify Philips Semiconductors for any damages resulting from such application.

Right to make changes — Philips Semiconductors reserves the right to make changes in the products - including circuits, standard cells, and/or software - described or contained herein in order to improve design and/or performance. When the product is in full production (status 'Production'), relevant changes will be communicated via a Customer Product/Process Change Notification (CPCN). Philips Semiconductors assumes no responsibility or liability for the use of any of these products, conveys no license or title under any patent, copyright, or mask work right to these products, and makes no representations or warranties that these products are free from patent, copyright, or mask work right infringement, unless otherwise specified.

19. Contact information

For additional information, please visit: <http://www.semiconductors.philips.com>

For sales office addresses, send an email to: sales.addresses@www.semiconductors.philips.com

20. Contents

1	General description	1
2	Features	1
3	Quick reference data	1
4	Ordering information	2
5	Marking	2
6	Functional diagram	3
7	Pinning information	3
7.1	Pinning	3
7.2	Pin description	3
8	Functional description	4
9	Limiting values	4
10	Recommended operating conditions	4
11	Static characteristics	5
12	Dynamic characteristics	8
13	Waveforms	12
14	Package outline	15
15	Revision history	17
16	Data sheet status	18
17	Definitions	18
18	Disclaimers	18
19	Contact information	18



© Koninklijke Philips Electronics N.V. 2004

All rights are reserved. Reproduction in whole or in part is prohibited without the prior written consent of the copyright owner. The information presented in this document does not form part of any quotation or contract, is believed to be accurate and reliable and may be changed without notice. No liability will be accepted by the publisher for any consequence of its use. Publication thereof does not convey nor imply any license under patent- or other industrial or intellectual property rights.

Date of release: 10 March 2004
Document order number: 9397 750 12887

Published in The Netherlands