

# DATA SHEET

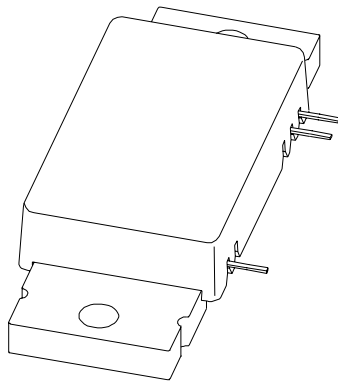

## **BGF944** GSM900 EDGE power module

Preliminary specification

2002 Nov 07

# GSM900 EDGE power module

# BGF944

## FEATURES

- Low distortion to a GSM EDGE signal.
- Excellent 2-tone performance
- Low die temperature using copper flange
- Integrated temperature compensated bias
- 50 Ω input/output system
- Flat gain over frequency.

## APPLICATIONS

- Base station RF power amplifiers in the 920 to 960 MHz frequency band.
- GSM, GSM EDGE, multi carrier applications
- Macrocell (driver) and microcell (final)

## DESCRIPTION

17 W power amplifier module for base station amplifier applications in 920 to 960 MHz band. Typical GSM EDGE performance at a supply voltage of 26 V:

Output power = 2.5 W

Gain = 29 dB

Efficiency = 15%

ACPR < -65 dBc at 400 kHz

rms EVM < 0.4%

peak EVM < 1.2%.

## PINNING - SOT365C

PIN	DESCRIPTION
1	RF input
2	V <sub>S</sub>
3	RF output
Flange	ground

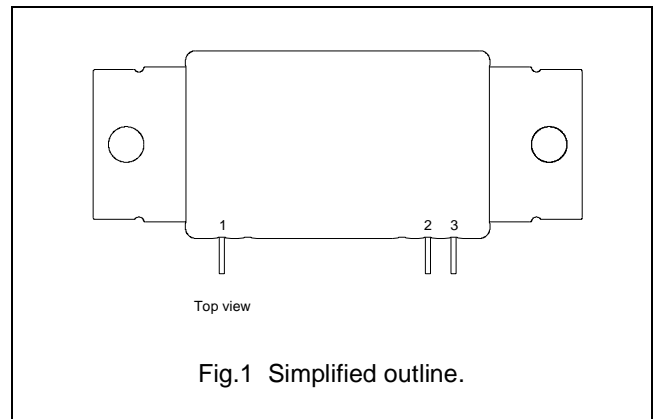

## QUICK REFERENCE DATA

Typical RF performance at T<sub>mb</sub> = 25 °C.

MODE OF OPERATION	f (MHz)	V <sub>S</sub> (V)	P <sub>L</sub> (W)	G <sub>p</sub> (dB)	η (%)	ACPR (dBc)	rms EVM (%)
CW	920 to 960	26	17	28	47	–	–
GSM EDGE	920 to 960	26	2.5	29	15	–65 <sup>(1)</sup>	0.4

### Note

1. ACPR 400 kHz at 30 kHz resolution bandwidth.

MODE OF OPERATION	f (MHz)	V <sub>S</sub> (V)	P <sub>L</sub> (W)	G <sub>p</sub> (dB)	IMD3 (dB)	IMD5 (dB)	IMD7 (dB)
2-tone	920 to 960	26	2.5	29	–44	–52	–60

## GSM900 EDGE power module

BGF944

## LIMITING VALUES

In accordance with the Absolute Maximum Rating System (IEC 60134).

SYMBOL	PARAMETER	MIN.	MAX.	UNIT
$V_S$	DC supply voltage	–	30	V
$P_D$	input drive power	–	100	mW
$P_L$	load power	–	24	W
$T_{stg}$	storage temperature range	–30	+100	°C
$T_{mb}$	operating mounting base temperature range	0	+90	°C

## CHARACTERISTICS

 $T_{mb} = 25\text{ °C}$ ;  $V_S = 26\text{ V}$ ;  $P_L = 2.5\text{ W}$ ;  $f = 920 - 960\text{ MHz}$ ;  $Z_S = Z_L = 50\text{ }\Omega$ ; unless otherwise specified.

SYMBOL	PARAMETER	CONDITIONS	MIN.	TYP.	MAX.	UNIT
$I_{DQ}$	quiescent current (pin 2)	$P_D = 0\text{ mW}$	–	280	320	mA
$P_{1dB}$	load power	at 1 dB gain compression	13	17	–	W
$G_p$	power gain		27	29	31	dB
$\Delta G_p - \text{freq}$	gain flatness vs freq.		–	0.2	1.0	dB
$\Delta G_p - \text{pwr}$	gain flatness vs power	$P_L = 25\text{ mW}$ up to 2.5 W	–0.8	–0.2	0.2	dB
$G_{OB}$	out of band gain	small signal, $P_D = 0\text{ dBm}$ ; $f < 920\text{ MHz}$ , $f > 960\text{ MHz}$	–	–	$G_{pi\text{ max}} + 1$ note 1	dB
$VSWR_{in}$	input VSWR		–	1.6 : 1	2.0 : 1	
$IMD_r$	reverse intermodulation	$f_i = f_c \pm 200\text{ kHz}$ ; $P_{carrier} = 2.5\text{ W}$ ; $P_{interference} = -40\text{ dBc}$ ;	–	–66	–60	dBc
H2	2 <sup>nd</sup> harmonic		–	–38	–35	dBc
H3	3 <sup>rd</sup> harmonic		–	–61	–58	dBc
	stability	$VSWR \leq 3 : 1$ through all phases; $V_{S2} = 25\text{ to }28\text{ V}$	all spurious outputs more than 60 dB below desired signal			
	ruggedness	$VSWR = 10 : 1$ through all phases; $P_L = 5\text{ W}$	no degradation in output power			
<b>EDGE (<math>P_L = 2.5\text{ W avg}</math>)</b>						
$\eta$	efficiency		12	15	–	%
SR200	spectral regrowth; EDGE GSM signal	200 kHz	–	–36	–35	dBc
SR400		400 kHz	–	–65	–63	dBc
EVM	rms EDGE signal distortion		–	0.4	1.2	%
	peak EDGE signal distortion		–	1.2	4	%
<b>Intermodulation distortion</b>						
$d_3$	third order intermodulation	$P_L = 2.5\text{ W average}$ ; carrier spacing = 200 kHz	–	–44	–40	dBc
$d_5$	fifth order intermodulation		–	–52	–	dBc
$d_7$	seventh order intermodulation		–	–60	–	dBc

## Notes

- $G_{pi}$  is small signal in band gain.

GSM900 EDGE power module

BGF944

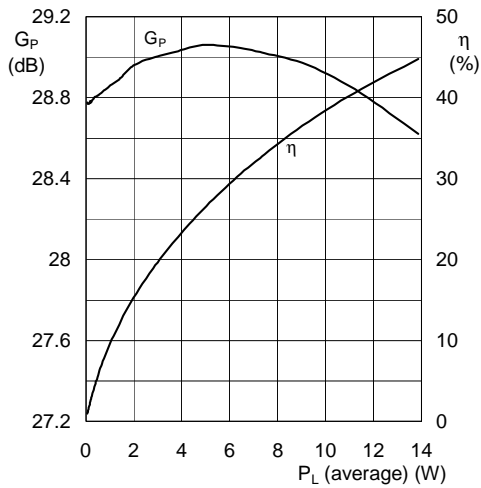

f = 940 MHz

Fig.2 GSM EDGE gain and efficiency as functions of load power; typical values.

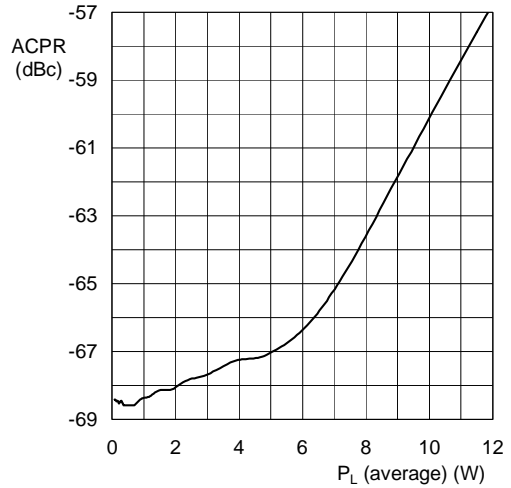

f = 940 MHz

Fig.3 GSM EDGE ACPR at 400 kHz as a function of load power; typical values.

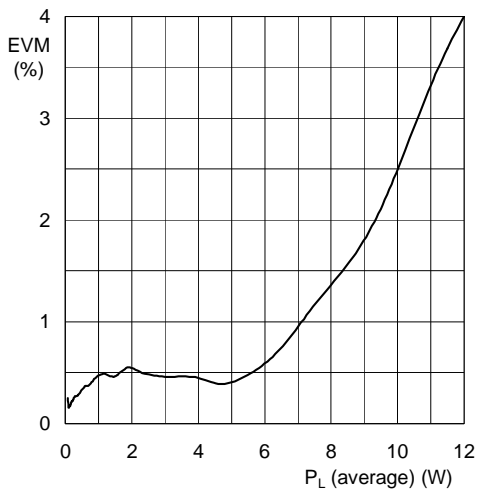

f = 940 MHz.

Fig.4 GSM EDGE rms EVM as a function of load power; typical values.

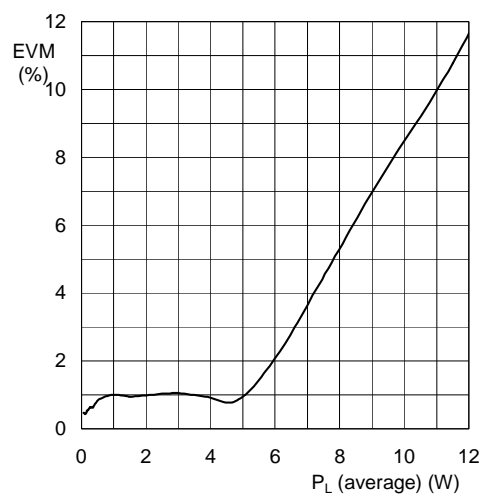

f = 940 MHz.

Fig.5 GSM EDGE peak EVM as function of load power; typical values.

GSM900 EDGE power module

BGF944

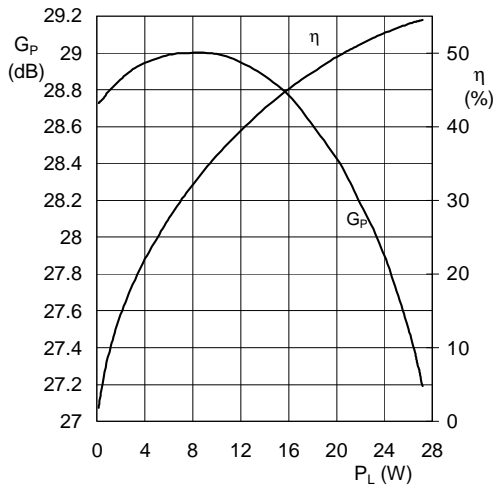

$f = 940$  MHz.

Fig.6 CW gain and efficiency as functions of load power; typical values.

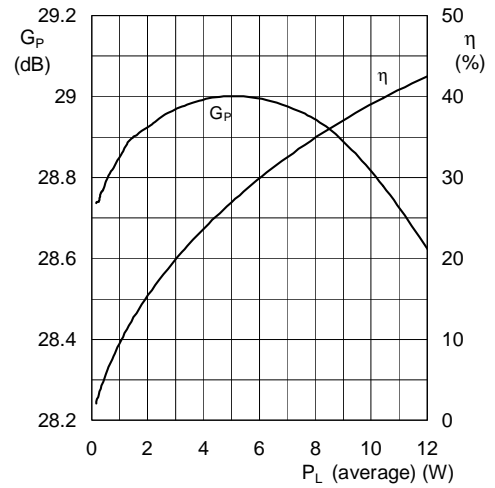

$f_1 = 940$  MHz;  $f_2 = 941$  MHz.

Fig.7 Two tone gain and efficiency as functions of load power; typical values.

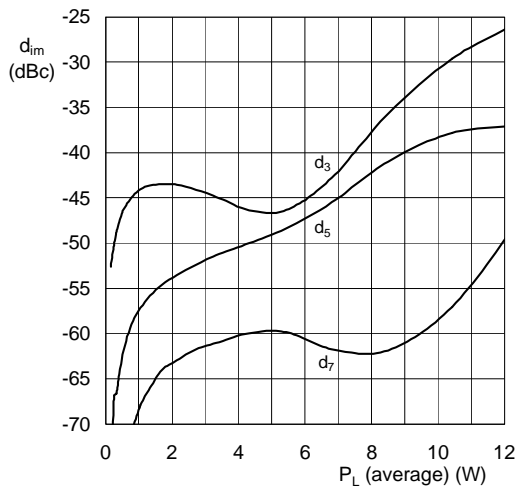

$f_1 = 940$  MHz;  $f_2 = 941$  MHz.

Fig.8 Two tone intermodulation distortion as function of load power; typical values.

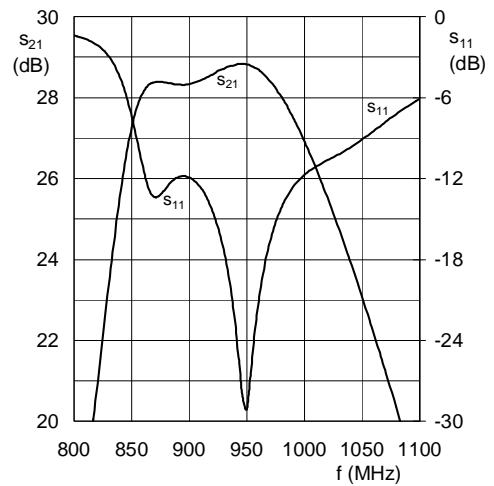

Fig.9 S-parameters as a function of frequency

---

## GSM900 EDGE power module

## BGF944

---

### MOUNTING RECOMMENDATIONS

#### Introduction

LDMOST basestation modules are manufactured with the dies directly mounted on a copper flange. The matching- and bias circuit components are mounted on a printed circuit board (PCB), which is also soldered onto the copper flange. This construction is able to withstand marginal bending, although bending has to be avoided as much as possible. Reason for excessive bending can be mismatch between the flatness of the module flange and the casting (external heatsink) of the amplifier. Mechanical stress can also be caused by thermal mismatch (after soldering the leads). To avoid this, precautions have to be taken during assembly of the module in the amplifier. Furthermore, a good thermal contact between flange and external heatsink is recommended.

#### The external heatsink (amplifier casting)

The module should always be mounted on a heatsink with a low thermal resistance to keep the temperature of the module as low as possible. The mounting area of the heatsink should be flat and free from burrs and loose particles. We recommend a flatness for the mounting area between 50 µm concave and 50 µm convex. The 50 µm concave limit is to assure an optimal thermal behaviour, while the 50 µm convex limit is intended to prevent the build-up of excessive mechanical stress due to bending.

In order to ensure thermal behaviour it is recommended to apply a thin evenly spread layer of thermal compound between the module and the mounting area.

Recommended thermal compounds have a  $K > 0.5$  W/mK, such as:

- WPS II (silicone-free) from Austerlitz-Electronics
- Comp. Trans. from KF
- 340 from Dow Corning
- Trans-Heat from E. Friis-Mikkelsen.

We do not support the use of thermal pads instead of thermal compound because of the risk of unflatness of the thermal pads during use.

#### Mounting sequence of the module

1. ESD precautions must be taken to protect the device from electro-static damage.
2. A thin, evenly spread layer of thermal compound shall be used between the module flange and the external heatsink to achieve the best possible thermal contact. Excessive use of thermal compound may result in an increase in thermal resistance and possible bending of the flange. There must always be room for the excessive thermal compound to escape. Too little thermal compound will result in an increase of thermal resistance.
3. Attention must be given to surface finish and cleanliness of the mounting surface.
4. Place the module to the external heatsink, such that there is some free distance between the cap and the printed circuit board.
5. Use 3 mm bolts with flat washers.
6. Both bolts should be tightened at first to "finger tight" (this is approx. 0.05 Nm).
7. Use torque wrench.
8. Tighten in alternating steps to a final torque of 0.4 Nm.
9. After mounting the module on the casting, the module leads can be soldered to the printed circuit board. The leads are intended for making electrical connections to the module and are not intended to support the module at any time in the assembly process.
10. A soldering iron may be used up to a temperature of 250 °C for a maximum of 10 seconds. Avoid contact between the soldering iron and the plastic cap.

---

**GSM900 EDGE power module****BGF944**

---

**Electrical connections**

The main ground path of all modules is via the flange. It is therefore important that the flange is well grounded and that return paths are kept as short as possible. A not proper flange grounding can result in a loss of output power or in oscillation.

The RF input and output of the module is designed for 50 Ohm terminations.

**Incomming inspection**

In case an incomming inspection is donbe, use a proper disigned testfixture to avoid excessive mechanical stress and to assure a optimal RF performance. On request Philips can deliver dedicated designed testfixtures.

GSM900 EDGE power module

BGF944

APPLICATION INFORMATION

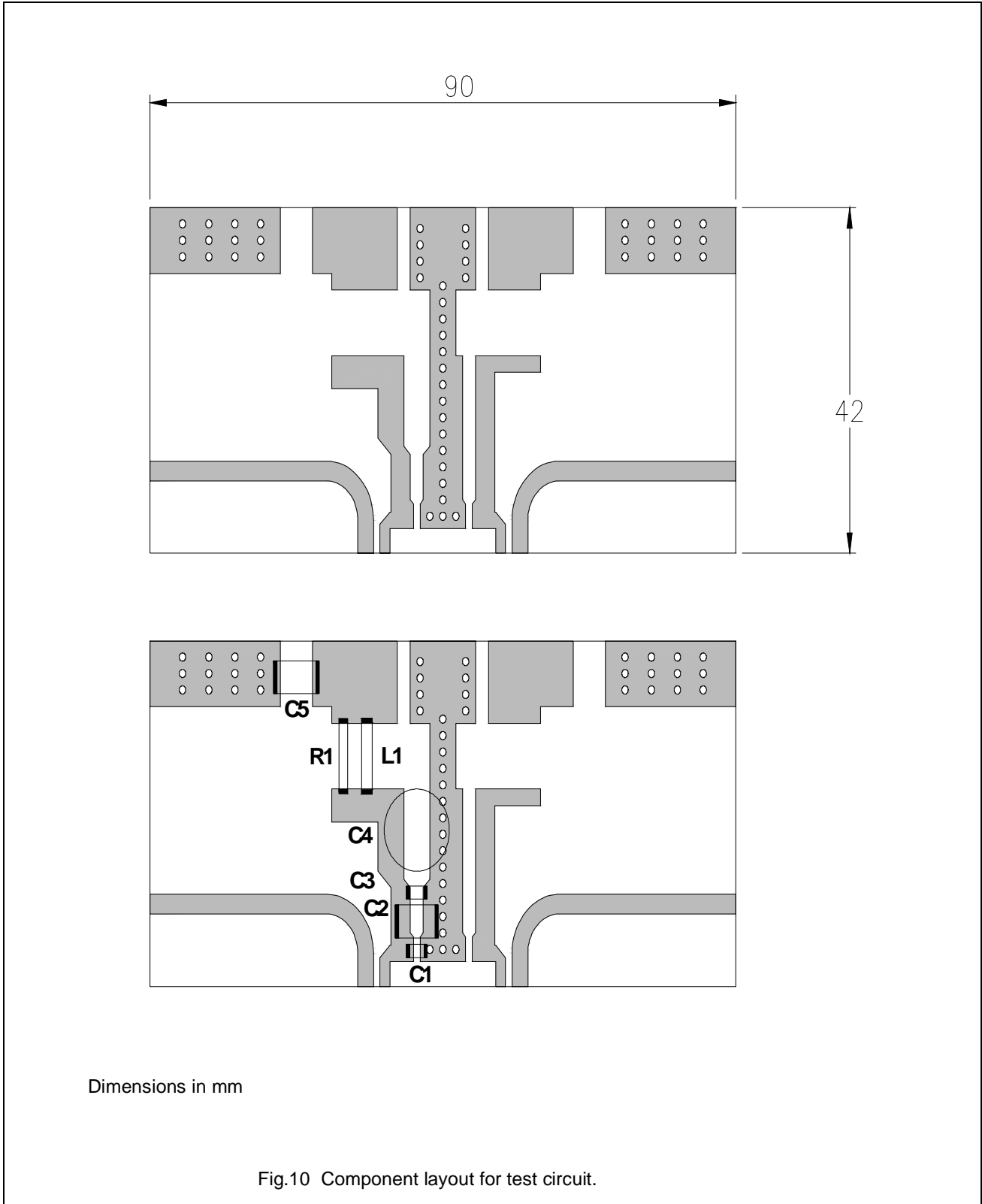

GSM900 EDGE power module

BGF944

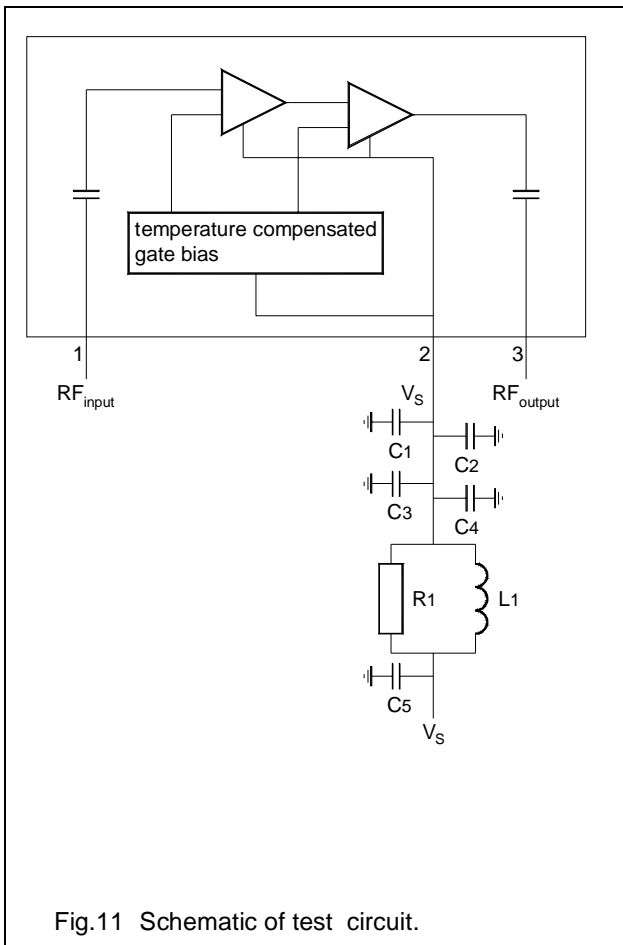

Fig.11 Schematic of test circuit.

List of components

COMPONENT	DESCRIPTION	VALUE	CATALOGUE NUMBER
C1, C3	multilayer X7R ceramic chip capacitor	100 nF; 50 V	
C2, C5	tantalium SMD capacitor	10 $\mu$ F; 35 V	
C4	electrolytic capacitor	100 $\mu$ F; 35 V	
L1	grade 4S2 Ferroxcube bead		4330 030 36300
R1	metal film resistor		2322 195 13109

# GSM900 EDGE power module

# BGF944

## PACKAGE OUTLINE

Plastic rectangular single-ended flat package; flange mounted; 2 mounting holes; 3 in-line leads

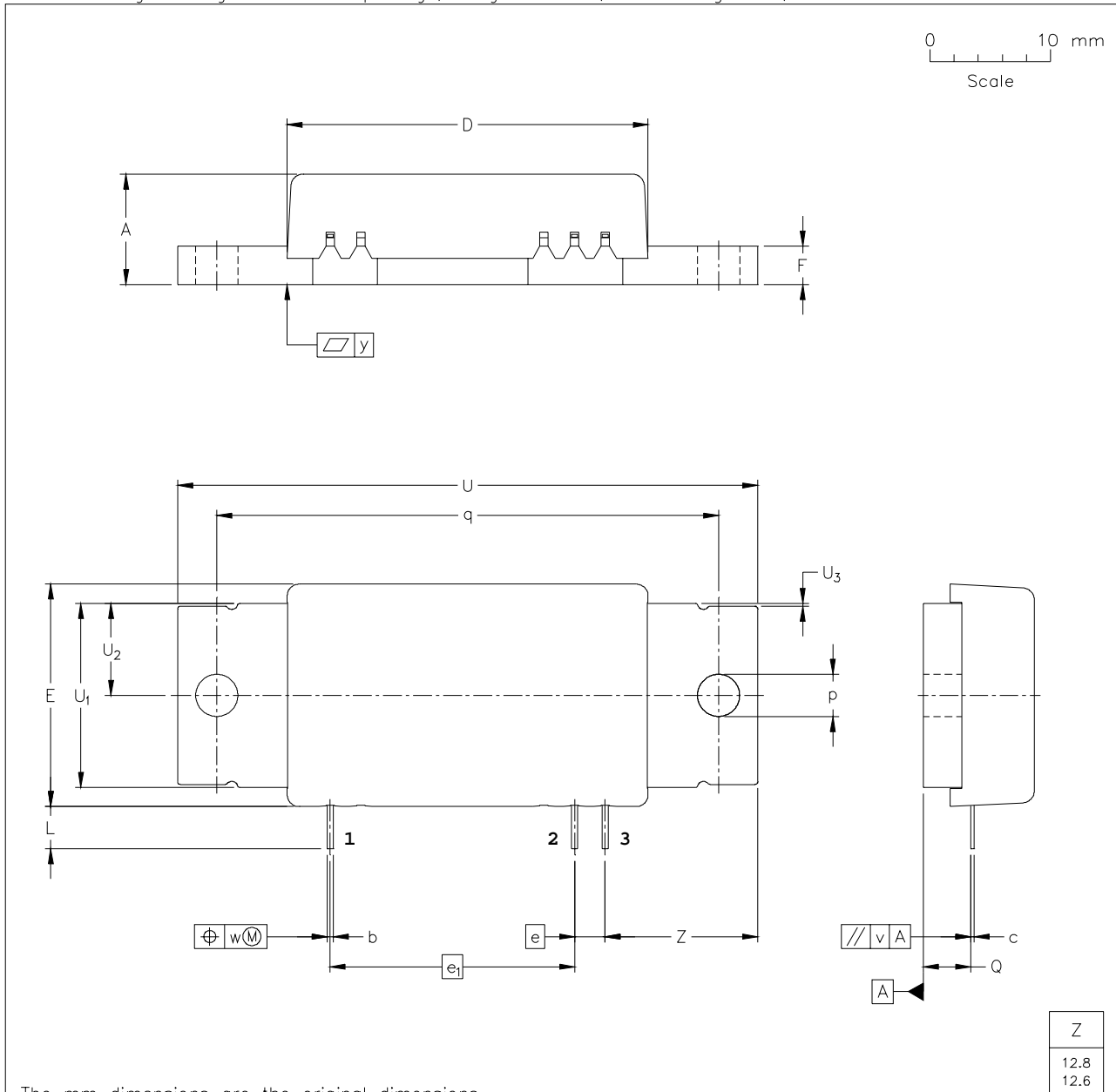

The mm dimensions are the original dimensions.

UNIT	A	b	c	D	E	e	e <sub>1</sub>	F	L	p	Q	q	U	U <sub>1</sub>	U <sub>2</sub>	U <sub>3</sub>	v	w	y
mm	9.5 9.0	0.56 0.46	0.30 0.20	30.1 29.9	18.6 18.4	2.54	20.32	3.3 3.1	3.7 3.3	3.55 3.45	4.0 3.8	41.75 41.65	48.4 48.0	15.4 15.2	7.75 7.55	1.1 0	0.3	0.25	0.1

PACKAGE OUTLINE VERSION	REFERENCES			EUROPEAN PROJECTION	ISSUE DATE
	IEC	JEDEC	EIAJ		
SOT365C PUBLICATION DRAWING					02-02-08

## GSM900 EDGE power module

BGF944

## DATA SHEET STATUS

LEVEL	DATA SHEET STATUS <sup>(1)</sup>	PRODUCT STATUS <sup>(2)(3)</sup>	DEFINITION
I	Objective data	Development	This data sheet contains data from the objective specification for product development. Philips Semiconductors reserves the right to change the specification in any manner without notice.
II	Preliminary data	Qualification	This data sheet contains data from the preliminary specification. Supplementary data will be published at a later date. Philips Semiconductors reserves the right to change the specification without notice, in order to improve the design and supply the best possible product.
III	Product data	Production	This data sheet contains data from the product specification. Philips Semiconductors reserves the right to make changes at any time in order to improve the design, manufacturing and supply. Relevant changes will be communicated via a Customer Product/Process Change Notification (CPCN).

## Notes

1. Please consult the most recently issued data sheet before initiating or completing a design.
2. The product status of the device(s) described in this data sheet may have changed since this data sheet was published. The latest information is available on the Internet at URL <http://www.semiconductors.philips.com>.
3. For data sheets describing multiple type numbers, the highest-level product status determines the data sheet status.

## DEFINITIONS

**Short-form specification** — The data in a short-form specification is extracted from a full data sheet with the same type number and title. For detailed information see the relevant data sheet or data handbook.

**Limiting values definition** — Limiting values given are in accordance with the Absolute Maximum Rating System (IEC 60134). Stress above one or more of the limiting values may cause permanent damage to the device. These are stress ratings only and operation of the device at these or at any other conditions above those given in the Characteristics sections of the specification is not implied. Exposure to limiting values for extended periods may affect device reliability.

**Application information** — Applications that are described herein for any of these products are for illustrative purposes only. Philips Semiconductors make no representation or warranty that such applications will be suitable for the specified use without further testing or modification.

## DISCLAIMERS

**Life support applications** — These products are not designed for use in life support appliances, devices, or systems where malfunction of these products can reasonably be expected to result in personal injury. Philips Semiconductors customers using or selling these products for use in such applications do so at their own risk and agree to fully indemnify Philips Semiconductors for any damages resulting from such application.

**Right to make changes** — Philips Semiconductors reserves the right to make changes in the products - including circuits, standard cells, and/or software - described or contained herein in order to improve design and/or performance. When the product is in full production (status 'Production'), relevant changes will be communicated via a Customer Product/Process Change Notification (CPCN). Philips Semiconductors assumes no responsibility or liability for the use of any of these products, conveys no licence or title under any patent, copyright, or mask work right to these products, and makes no representations or warranties that these products are free from patent, copyright, or mask work right infringement, unless otherwise specified.

# ***Philips Semiconductors – a worldwide company***

## **Contact information**

For additional information please visit <http://www.semiconductors.philips.com>. Fax: +31 40 27 24825

For sales offices addresses send e-mail to: [sales.addresses@www.semiconductors.philips.com](mailto:sales.addresses@www.semiconductors.philips.com).

© Koninklijke Philips Electronics N.V. 2001

SCA73

All rights are reserved. Reproduction in whole or in part is prohibited without the prior written consent of the copyright owner.

The information presented in this document does not form part of any quotation or contract, is believed to be accurate and reliable and may be changed without notice. No liability will be accepted by the publisher for any consequence of its use. Publication thereof does not convey nor imply any license under patent- or other industrial or intellectual property rights.

Printed in The Netherlands

613524/04/pp12

Date of release: 2002 Nov 07

Document order number: 9397 750 10678

*Let's make things better.*

**Philips  
Semiconductors**



**PHILIPS**