

DATA SHEET

BLW97 HF power transistor

Product specification

August 1986

HF power transistor

BLW97

DESCRIPTION

N-P-N silicon planar epitaxial transistor designed for use in class-A, AB and B operated high-power industrial and military transmitting equipment in the h.f. band.

The transistor offers excellent performance as a linear amplifier in s.s.b. applications. It is resistance stabilized and is made to withstand

severe load-mismatch conditions. All leads are isolated from the flange.

The transistors are supplied in matched h_{FE} groups.

QUICK REFERENCE DATA

R.F. performance up to $T_h = 25\text{ }^\circ\text{C}$

MODE OF OPERATION	V_{CE} V	$I_{C(ZS)}$ A	f MHz	P_L W	G_p dB	η_{dt} %	d_3 dB	d_5 dB
s.s.b. (class-AB)	28	0,1	1,6 – 28	175 (PEP)	> 11,5	> 40	< -30	< -30

PIN CONFIGURATION

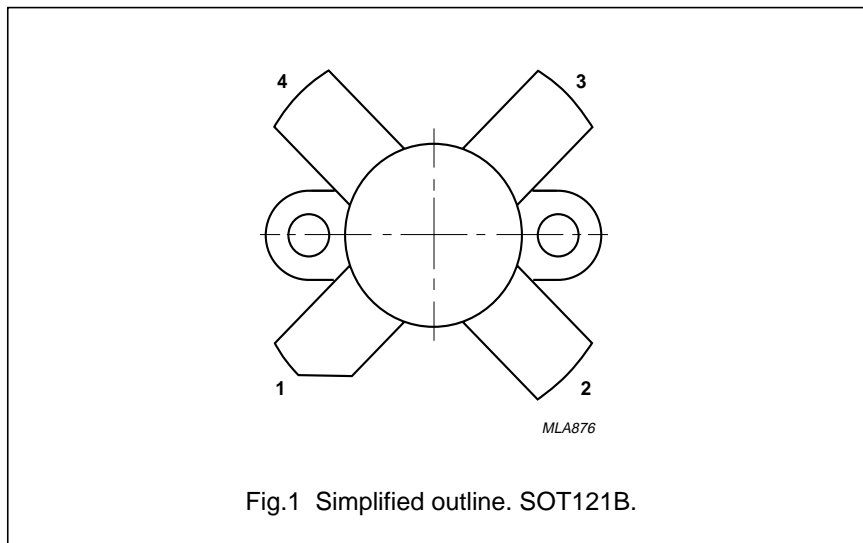

PINNING - SOT121B.

PIN	DESCRIPTION
1	collector
2	emitter
3	base
4	emitter

PRODUCT SAFETY This device incorporates beryllium oxide, the dust of which is toxic. The device is entirely safe provided that the BeO disc is not damaged.

HF power transistor

BLW97

RATINGS

Limiting values in accordance with the Absolute Maximum System (IEC 134)

Collector-emitter voltage (peak value)

$V_{BE} = 0$

open base

Emitter-base voltage (open collector)

Collector current

average

peak value; $f > 1$ MHz

Total d.c. power dissipation at $T_h = 25^\circ\text{C}$

R.F. power dissipation

$f > 1$ MHz; $T_h = 25^\circ\text{C}$

Storage temperature

Operating junction temperature

V_{CESM}	max.	65 V
V_{CEO}	max.	33 V
V_{EBO}	max.	4 V
$I_{C(AV)}$	max.	15 A
I_{CM}	max.	50 A
$P_{tot(d.c.)}$	max.	190 W
$P_{tot(rf)}$	max.	230 W
T_{stg}		-65 to +150 °C
T_j	max.	200 °C

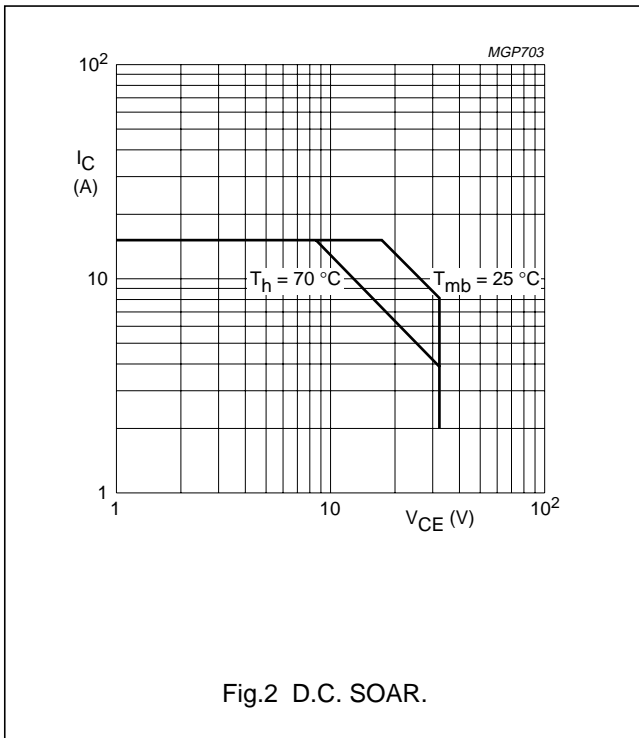
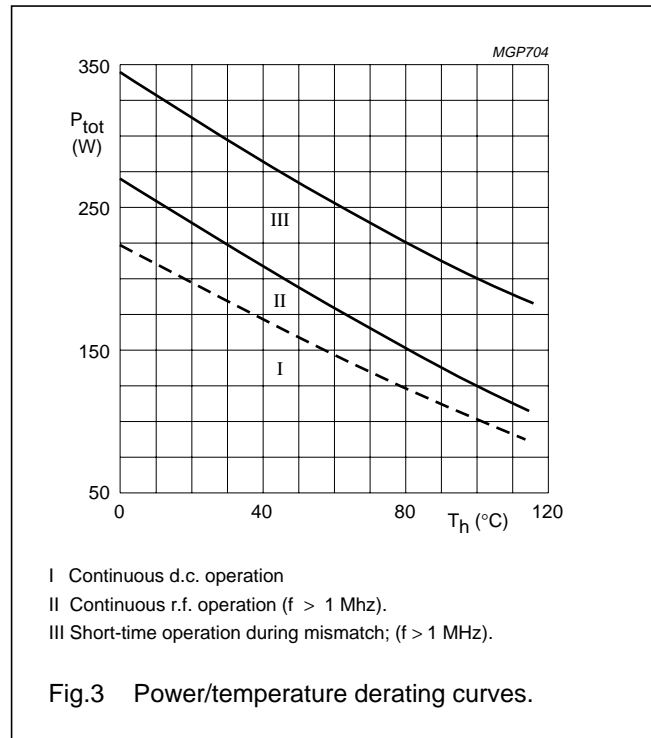

Fig.2 D.C. SOAR.



- I Continuous d.c. operation
- II Continuous r.f. operation ($f > 1$ Mhz).
- III Short-time operation during mismatch; ($f > 1$ MHz).

Fig.3 Power/temperature derating curves.

THERMAL RESISTANCE

(dissipation = 120 W; $T_h = 25^\circ\text{C}$ i.e. $T_{mb} = 49^\circ\text{C}$)

From junction to mounting base

(d.c. dissipation)

$$R_{th\ j-mb(dc)} = 0,63\ \text{K/W}$$

From junction to mounting base

(r.f. dissipation)

$$R_{th\ j-mb(rf)} = 0,48\ \text{K/W}$$

From mounting base to heatsink

$$R_{th\ mb-h} = 0,20\ \text{K/W}$$

HF power transistor

BLW97

CHARACTERISTICS $T_j = 25\text{ °C}$ unless otherwise specified

Collector-emitter breakdown voltage

 $V_{BE} = 0$; $I_C = 50\text{ mA}$ $V_{(BR)CES} > 65\text{ V}$ $I_C = 100\text{ mA}$; open base $V_{(BR)CEO} > 33\text{ V}$

Emitter-base breakdown voltage

 $I_E = 20\text{ mA}$; open collector $V_{(BR)EBO} > 4\text{ V}$

Collector cut-off current

 $V_{CE} = 33\text{ V}$; $V_{BE} = 0$ $I_{CES} < 20\text{ mA}$ Second breakdown energy; $L = 25\text{ mH}$; $f = 50\text{ Hz}$

open base

 $E_{SBO} > 20\text{ mJ}$ $R_{BE} = 10\ \Omega$ $E_{SBR} > 20\text{ mJ}$ D.C. current gain⁽¹⁾ $I_C = 10\text{ A}$; $V_{CE} = 5\text{ V}$

typ. 30

 $h_{FE} 15\text{ to }50$ D.C. current gain ratio of matched devices⁽¹⁾ $I_C = 10\text{ A}$; $V_{CE} = 5\text{ V}$ $h_{FE1}/h_{FE2} < 1,2$ Collector-emitter saturation voltage⁽¹⁾ $I_C = 25\text{ A}$; $I_B = 5\text{ A}$ V_{CEsat} typ. 2,4 VTransition frequency at $f = 100\text{ MHz}$ ⁽²⁾ $-I_E = 10\text{ A}$; $V_{CB} = 28\text{ V}$ f_T typ. 230 MHz $-I_E = 20\text{ A}$; $V_{CB} = 28\text{ V}$ f_T typ. 235 MHzCollector capacitance at $f = 1\text{ MHz}$ $I_E = I_e = 0$; $V_{CB} = 28\text{ V}$ C_c typ. 380 pFFeedback capacitance at $f = 1\text{ MHz}$ $I_C = 0$; $V_{CE} = 28\text{ V}$ C_{re} typ. 235 pF

Collector-flange capacitance

 C_{cf} typ. 4,5 pF**Notes**

1. Measured under pulse conditions: $t_p = 500\ \mu\text{s}$.
2. Measured under pulse conditions: $t_p = 300\ \mu\text{s}$; $\delta = 0,02$.

HF power transistor

BLW97

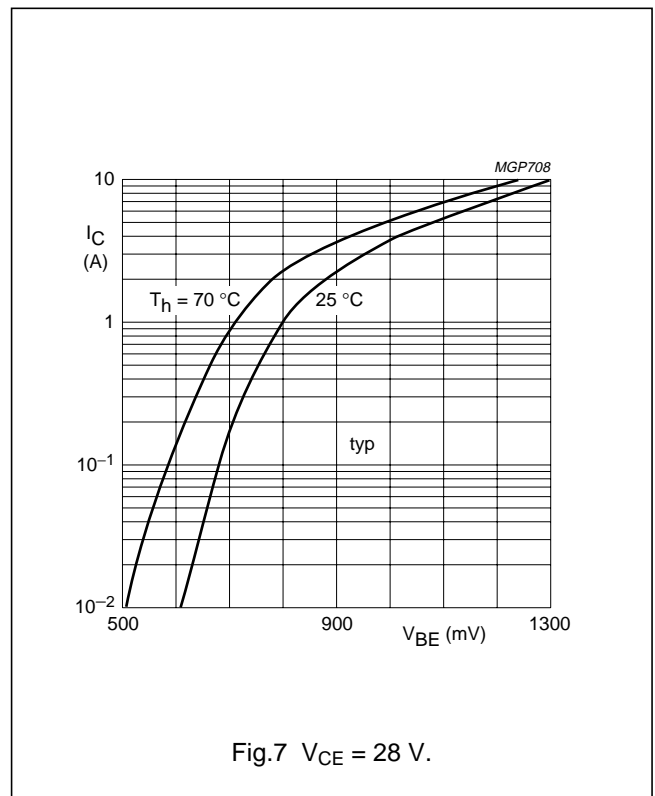
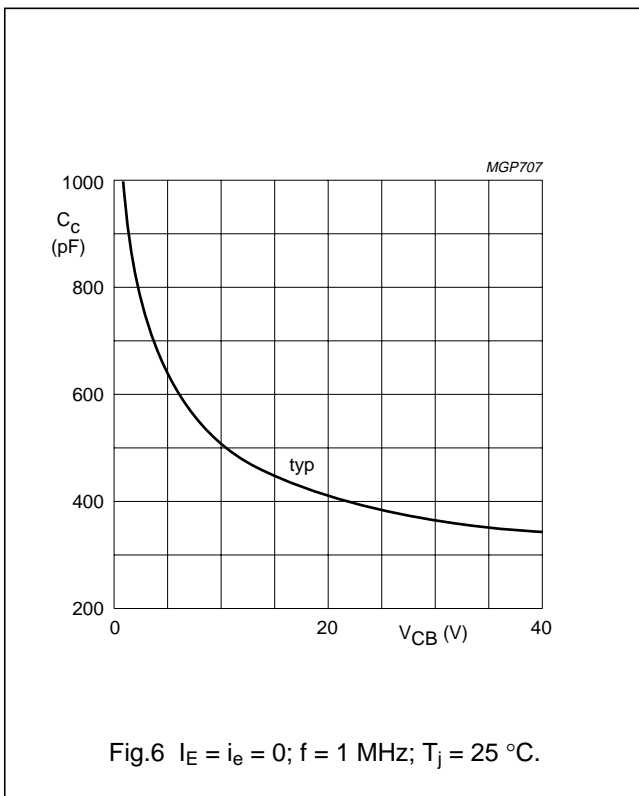
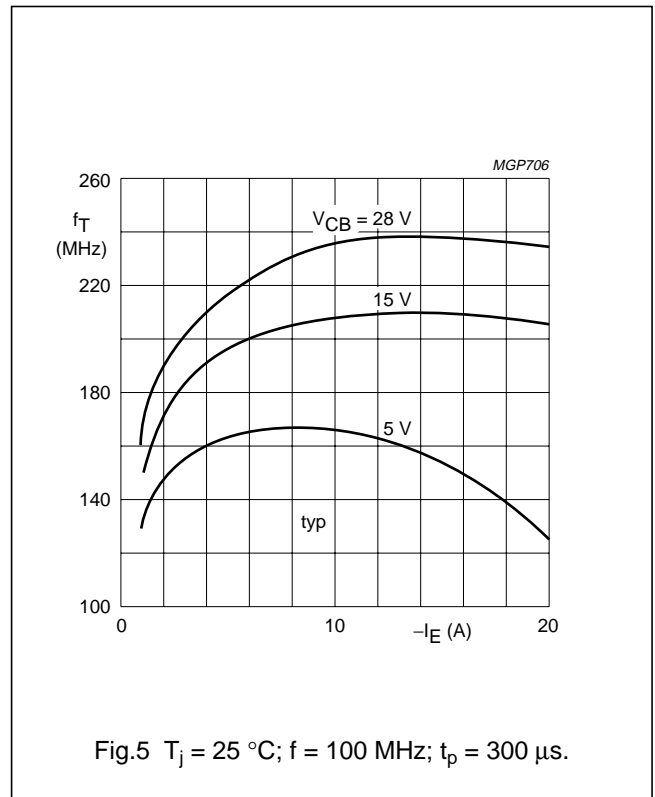
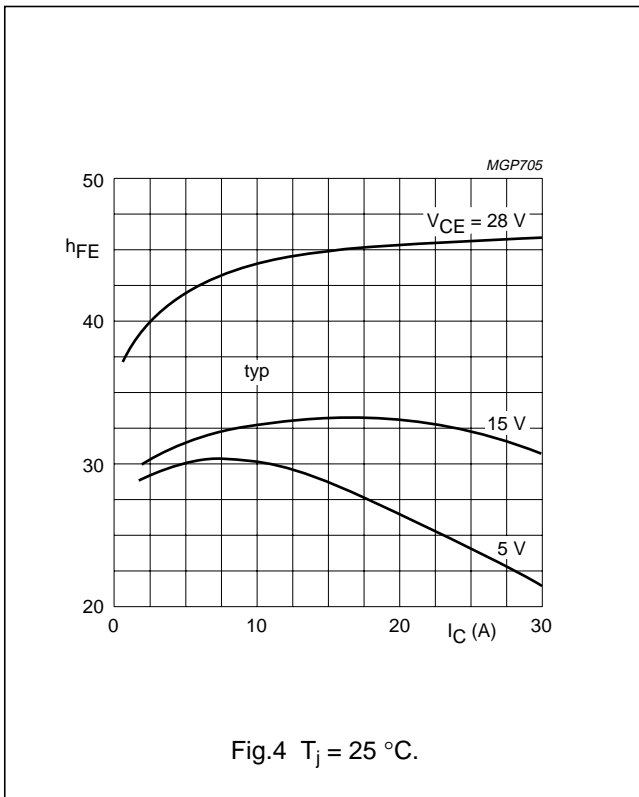

HF power transistor

BLW97

APPLICATION INFORMATION

R.F. performance in s.s.b. class-AB operation (linear power amplifier).

$V_{CE} = 28 \text{ V}$; $T_h = 25 \text{ }^\circ\text{C}$; $f_1 = 28,000 \text{ MHz}$; $f_2 = 28,001 \text{ MHz}$.

OUTPUT POWER W	G_p dB	η_{dt} %	I_c A	$d_3^{(1)}$ dB	$d_5^{(1)}$ dB	$I_{c(zs)}$ A
175 (PEP)	> 11,5 typ. 13,0	> 40 typ. 50	< 7,8 typ. 6,3	< -30 typ. -34	< -30 typ. -38	0,1

Note

1. The stated intermodulation distortion levels are referred to the according level of either of the equal amplified tones. Relative to the according peak envelope powers these figures should be increased by 6 dB.

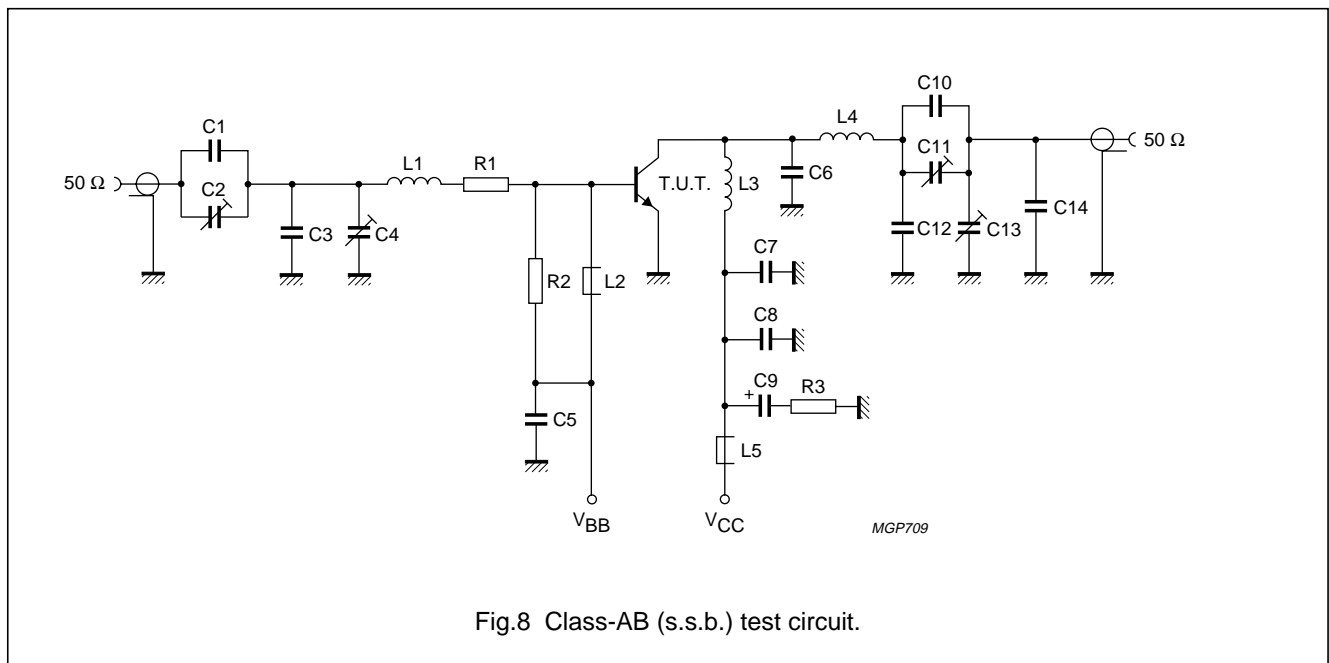

HF power transistor**BLW97**

List of components:

- C1 = 47 pF (500 V) multilayer ceramic chip capacitor⁽¹⁾
- C2 = 100 pF film dielectric trimmer
- C3 = 2 × 130 pF (300 V) multilayer ceramic chip capacitors in parallel⁽¹⁾
- C4 = 280 pF film dielectric trimmer
- C5 = 10 nF (50 V) multilayer ceramic chip capacitor 2222 856 13103
- C6 = 2 × 180 pF (300 V) multilayer ceramic chip capacitors in parallel⁽¹⁾
- C7 = 100 nF (50 V) multilayer ceramic chip capacitor 2222 856 48104
- C8 = 10 nF (50 V) multilayer ceramic chip capacitor 2222 856 13103
- C9 = 2,2 µF - 63 V solid aluminium electrolytic capacitor
- C10 = 5 × 82 pF (500 V) multilayer ceramic chip capacitors in parallel⁽¹⁾
- C11 = 250 pF air dielectric trimmer
- C12 = 5 × 33 pF ceramic feed-through capacitors mounted in parallel on a brass plate
- C13 = 100 pF air dielectric trimmer
- C14 = 3 × 91 pF (500 V) multilayer ceramic chip capacitors in parallel⁽¹⁾
- R1 = 0,7 Ω - 7 W (7 × 4,7 Ω - 1 W carbon resistors in parallel)
- R2 = 27 Ω - 0,25 W carbon resistor
- R3 = 4,7 Ω - 0,25 W carbon resistor
- L1 = 73 nH; 4 turns Cu wire (1,5 mm); int. dia. 7 mm; length 9,4 mm; leads 2 × 5 mm
- L2 = Ferroxcube wide-band h.f. choke grade 3B (cat. no. 4312 020 36640); 6 leads in parallel
- L3 = 70,4 nH; 4 turns Cu wire (2 mm); int. dia. 7 mm; length 14,8 mm; leads 2 × 5 mm
- L4 = 83,5 nH; 4 turns Cu wire (2 mm); int. dia. 8 mm; length 15 mm; leads 2 × 5 mm
- L5 = Ferroxcube wide-band h.f. choke grade 3 B (cat. no. 4312 020 36640) with 6 leads in parallel

Note

1. American Technical Ceramics capacitor or capacitor of same quality.

HF power transistor

BLW97

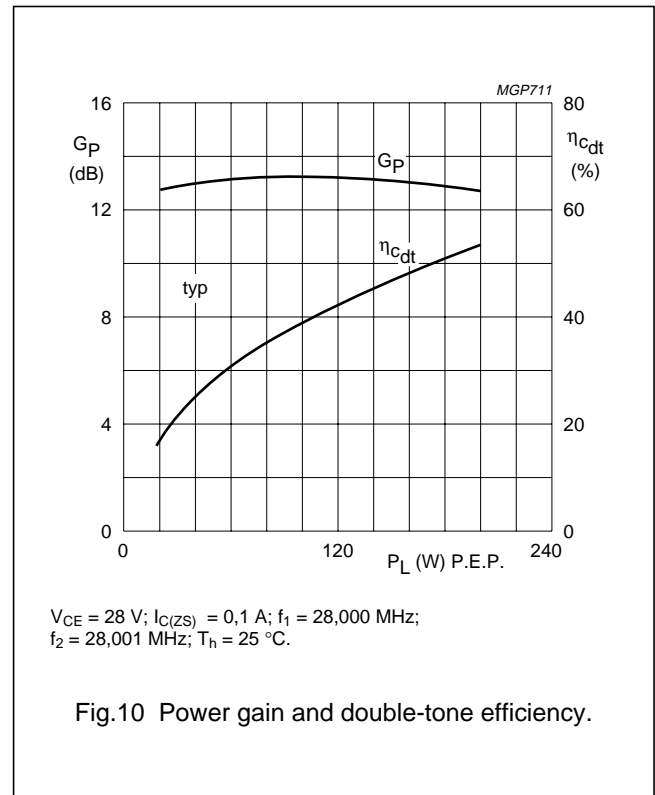
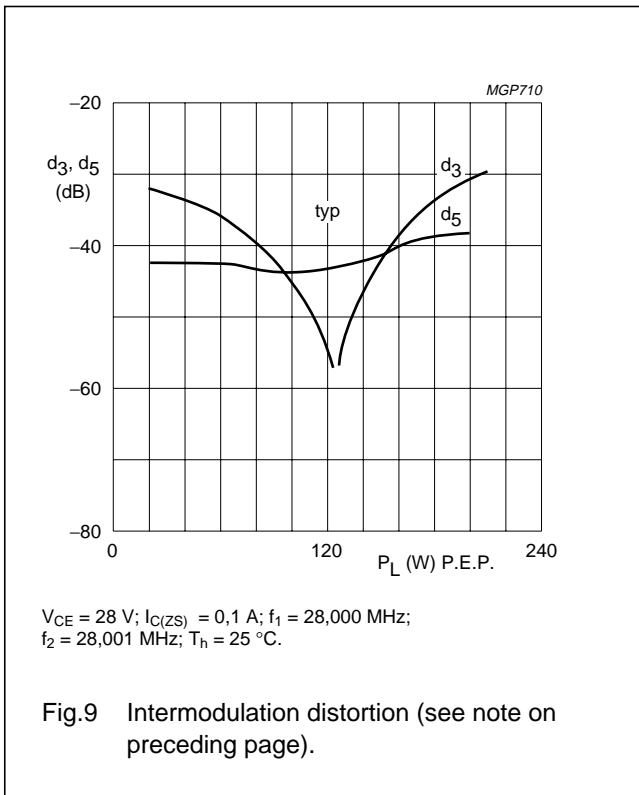

RUGGEDNESS

The BLW97 is capable of withstanding full load mismatch (VSWR = 50 through all phases) up to 150 W (P.E.P.) or a load mismatch (VSWR = 5 through all phases) up to 175 W (P.E.P.) under the following conditions:

$V_{CE} = 28 \text{ V}; f = 28 \text{ MHz}; T_h = 25 \text{ }^\circ\text{C}; R_{th \text{ mb-h}} = 0,2 \text{ K/W}.$

Figures 11 and 12 t typical curves which are valid for one transistor of a push-pull amplifier in s.s.b. class-AB operation.

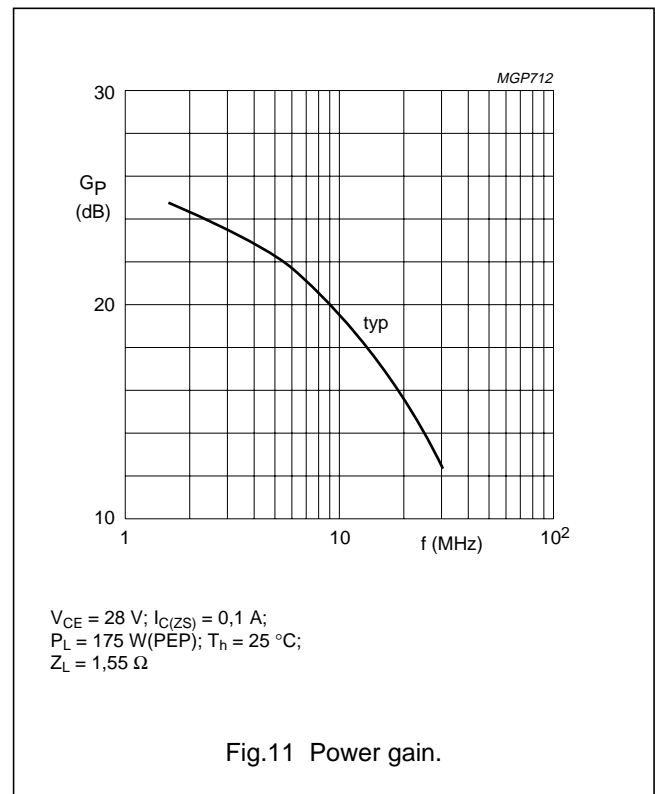

HF power transistor

BLW97

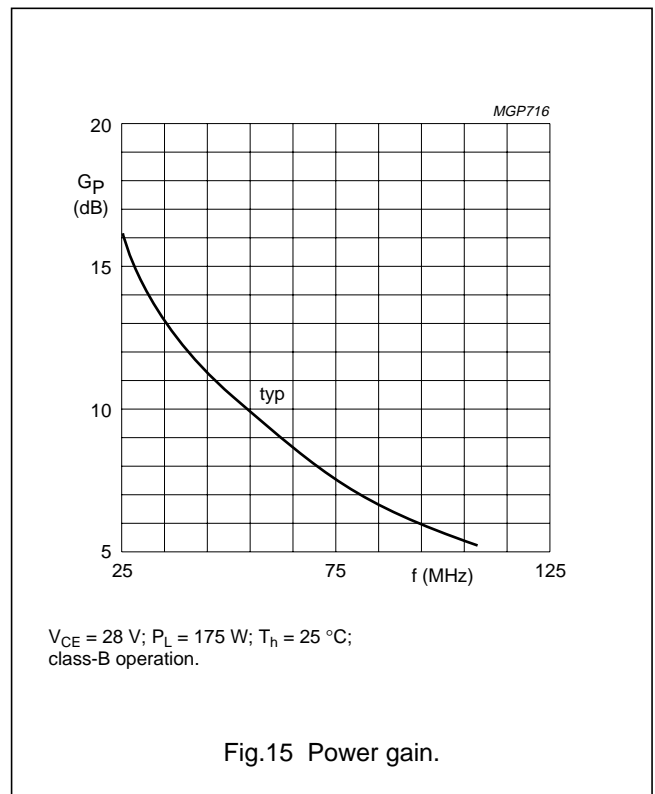
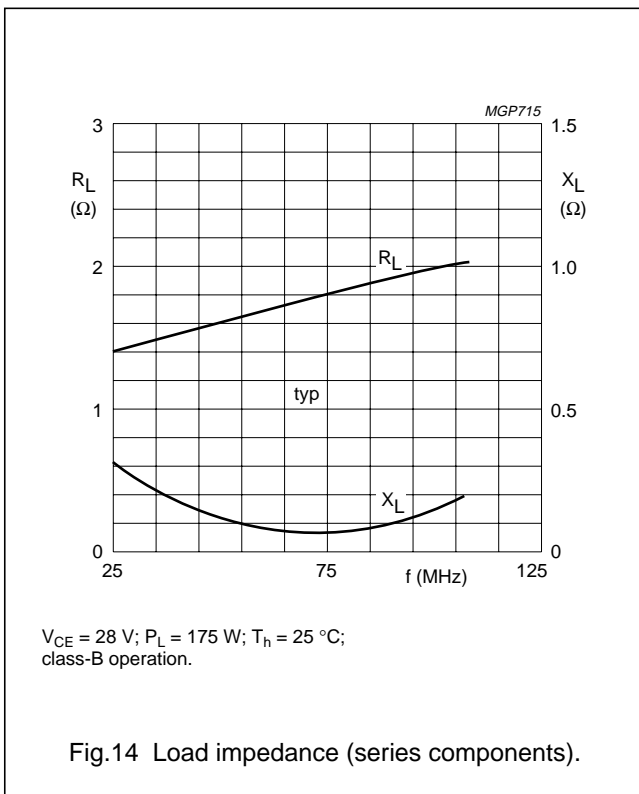
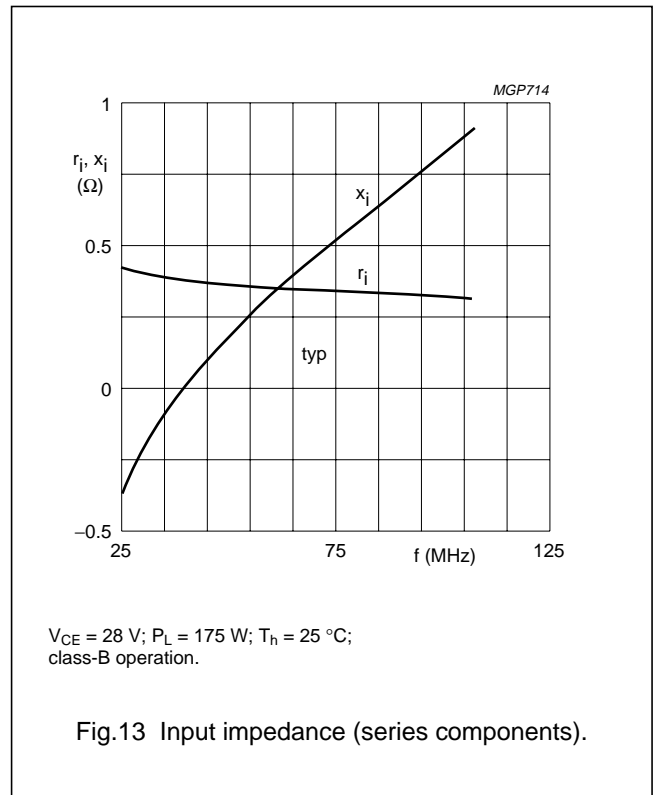
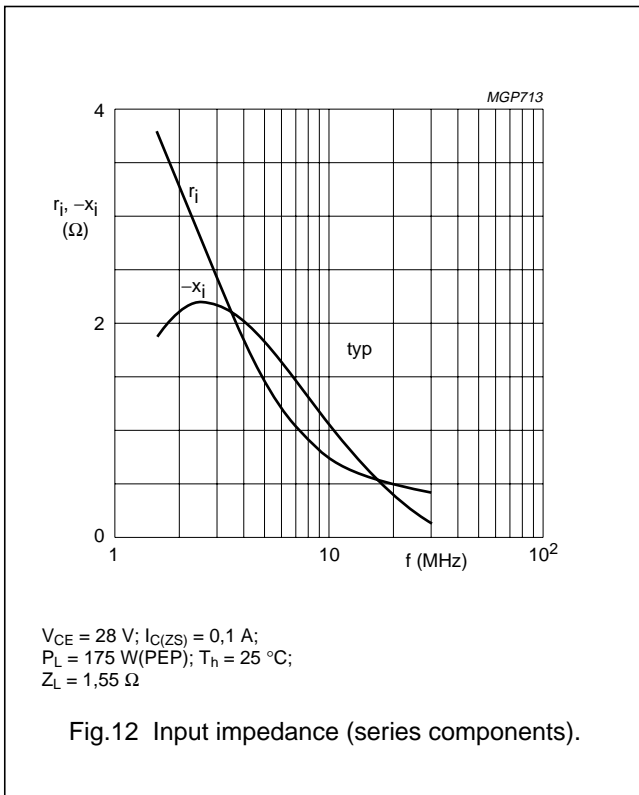

HF power transistor

BLW97

PACKAGE OUTLINE

Flanged ceramic package; 2 mounting holes; 4 leads

SOT121B

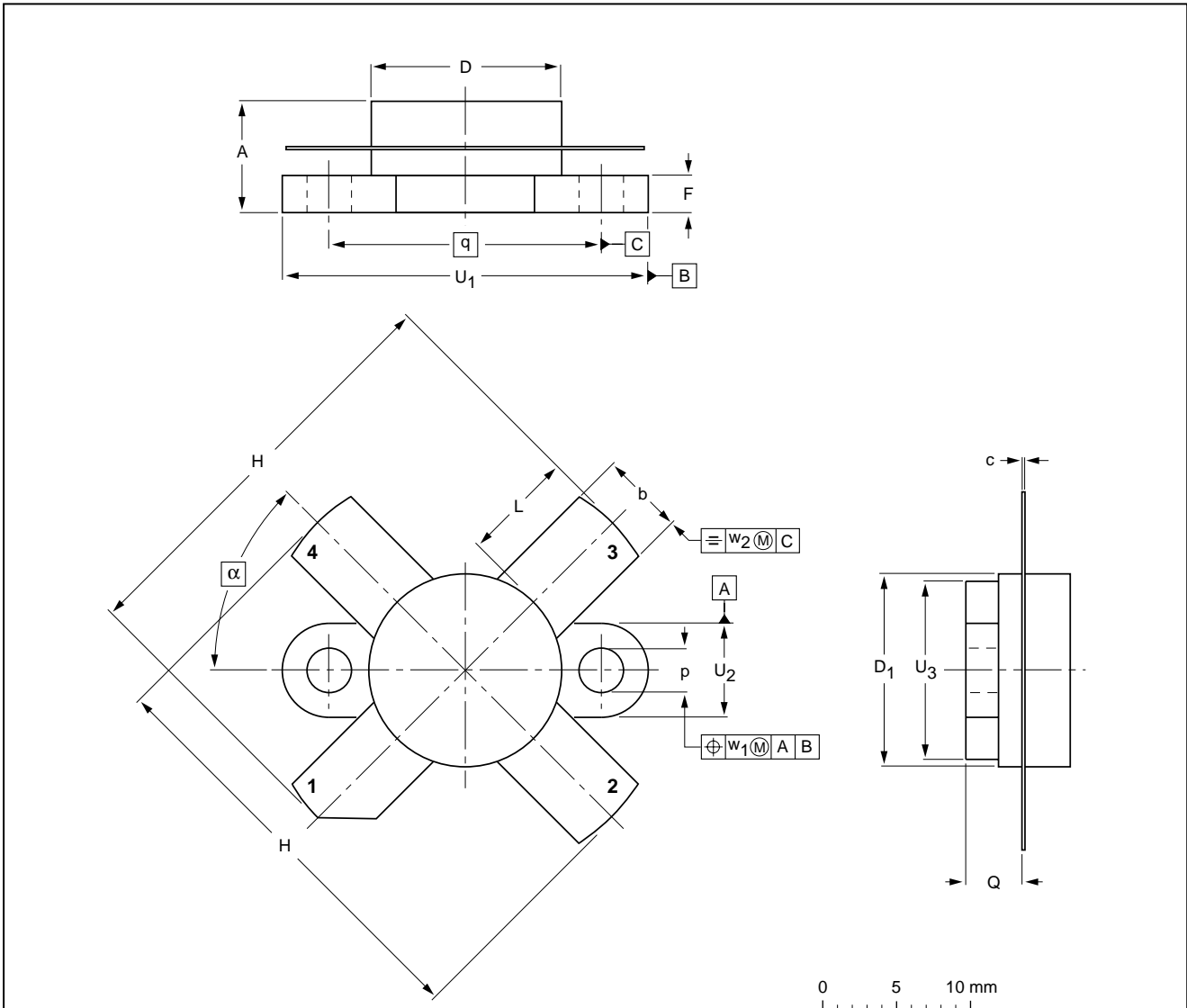

DIMENSIONS (millimetre dimensions are derived from the original inch dimensions)

UNIT	A	b	c	D	D ₁	F	H	L	p	Q	q	U ₁	U ₂	U ₃	w ₁	w ₂	α
mm	7.27 6.17	5.82 5.56	0.16 0.10	12.86 12.59	12.83 12.57	2.67 2.41	28.45 25.52	7.93 6.32	3.30 3.05	4.45 3.91	18.42	24.90 24.63	6.48 6.22	12.32 12.06	0.51	1.02	45°
inches	0.286 0.243	0.229 0.219	0.006 0.004	0.506 0.496	0.505 0.495	0.105 0.095	1.120 1.005	0.312 0.249	0.130 0.120	0.175 0.154	0.725	0.98 0.97	0.255 0.245	0.485 0.475	0.02	0.04	

OUTLINE VERSION	REFERENCES				EUROPEAN PROJECTION	ISSUE DATE
	IEC	JEDEC	EIAJ			
SOT121B						97-06-28

HF power transistor

BLW97

DEFINITIONS

Data Sheet Status	
Objective specification	This data sheet contains target or goal specifications for product development.
Preliminary specification	This data sheet contains preliminary data; supplementary data may be published later.
Product specification	This data sheet contains final product specifications.
Limiting values	
Limiting values given are in accordance with the Absolute Maximum Rating System (IEC 134). Stress above one or more of the limiting values may cause permanent damage to the device. These are stress ratings only and operation of the device at these or at any other conditions above those given in the Characteristics sections of the specification is not implied. Exposure to limiting values for extended periods may affect device reliability.	
Application information	
Where application information is given, it is advisory and does not form part of the specification.	

LIFE SUPPORT APPLICATIONS

These products are not designed for use in life support appliances, devices, or systems where malfunction of these products can reasonably be expected to result in personal injury. Philips customers using or selling these products for use in such applications do so at their own risk and agree to fully indemnify Philips for any damages resulting from such improper use or sale.