

# MC1488

## Quad line driver

Document No.	853-0933
ECN No.	86552
Date of Issue	November 14, 1986
Status	Product Specification
<b>Data Communication Products</b>	

### DESCRIPTION

The MC1488 is a quad line driver which converts standard DTL/TTL input logic levels through one stage of inversion to output levels which meet EIA Standard No. RS-232C and CCITT Recommendation V.24.

### FEATURES

- Current limited output:  $\pm 10\text{mA Typ}$
- Power-off source impedance:  $300\Omega \text{ min}$
- Simple slew rate control with external capacitor
- Flexible operating supply range
- Inputs are DTL/TTL compatible

### APPLICATIONS

- Computer port driver
- Digital transmission over long lines
- Slew rate control
- TTL/DTL-to-MOS translation

### PIN CONFIGURATION

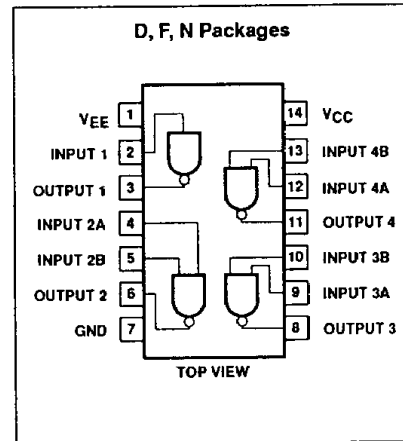

### CIRCUIT SCHEMATIC

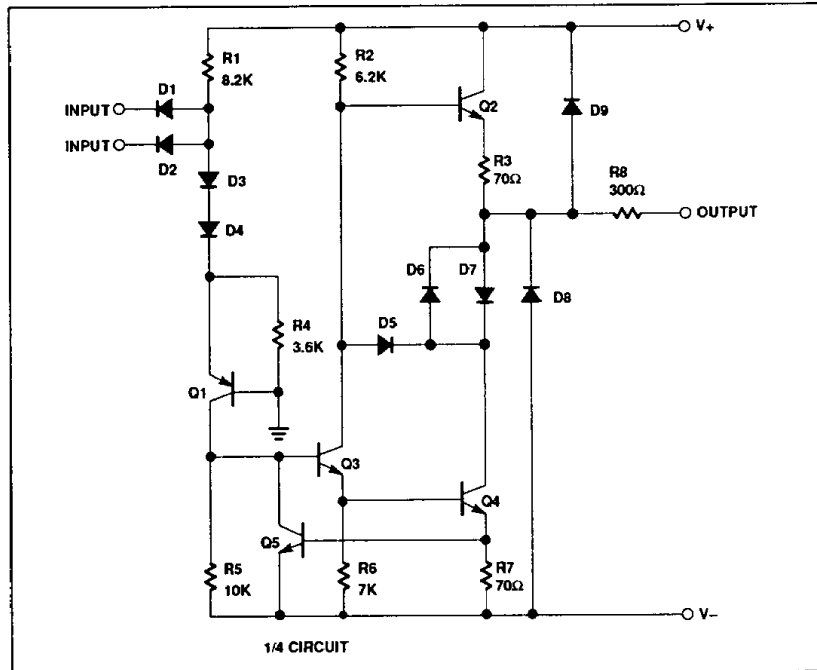

**Quad line driver****MC1488****ORDERING INFORMATION**

DESCRIPTION	TEMPERATURE RANGE	ORDER CODE
14-Pin Plastic SO	0°C to +75°C	MC1488D
14-Pin Plastic DIP	0°C to +75°C	MC1488N
14-Pin Ceramic DIP	0°C to +75°C	MC1488F

**ABSOLUTE MAXIMUM RATINGS**

SYMBOL	PARAMETER	RATING	UNIT
V <sub>CC</sub>	Supply voltage V+	+15	V
	V-	-15	V
V <sub>IN</sub>	Input voltage	-15 ≤ V <sub>IN</sub> ≤ 7.0	V
V <sub>OUT</sub>	Output voltage	±15	V
P <sub>D</sub>	Maximum power dissipation, T <sub>A</sub> = 25°C (still-air) <sup>1</sup>		
	F package	1190	mW
	N package	1420	mW
	D package	1040	mW
T <sub>A</sub>	Operating ambient temperature range	0 to +75	°C
T <sub>STG</sub>	Storage temperature range	-65 to +150	°C
T <sub>SOLD</sub>	Lead soldering temperature (10sec max)	300	°C

**NOTE:**

- Derate above 25°C, at the following rates:  
 F package at 9.5mW/°C.  
 N package at 11.4mW/°C.  
 D package at 8.3mW/°C.

## Quad line driver

MC1488

**DC AND AC ELECTRICAL CHARACTERISTICS**  $V_+ = +9.0V \pm 1\%$ ,  $V_- = -9.0V \pm 1\%$ ,  $T_A = 0^\circ\text{C}$  to  $+75^\circ\text{C}$ , unless otherwise specified. All typicals are for  $V_+ = 9.0V$ ,  $V_- = -9.0V$ , and  $T_A = 25^\circ\text{C}$ <sup>1</sup>

SYMBOL	PARAMETER	TEST CONDITIONS	LIMITS			UNIT		
			Min	Typ	Max			
$V_{IH}$	Logic "0" input current	$V_{IN} = 0V$		-1.0	-1.6	mA		
$V_{IL}$	Logic "1" input current	$V_{IN} = +5.0V$		0.005	10.0	$\mu\text{A}$		
$V_{OH}$	High level output voltage	$R_L = 3.0k\Omega$ $V_{IN} = 0.8V$	$V_+ = 9.0V$ $V_- = -9.0V$	6.0	7.0	V		
			$V_+ = 13.2V$ $V_- = -13.2V$	9.0	10.5	V		
$V_{OL}$	Low level output voltage	$R_L = 3.0k\Omega$ $V_{IN} = 1.9V$	$V_+ = 9.0V$ $V_- = -9.0V$	-6.0	-6.8	V		
			$V_+ = 13.2V$ $V_- = -13.2V$	-9.0	-10.5	V		
$I_{sc+}$	High level output short-circuit current	$V_{OUT} = 0V$ $V_{IN} = 0.8V$	-6.0	-10.0	-12.0	mA		
$I_{sc-}$	Low level output short-circuit current	$V_{OUT} = 0V$ $V_{IN} = 1.9V$	5.0	10.0	12.0	mA		
$R_{OUT}$	Output resistance	$V_+ = V_- = 0V$ $V_{OUT} = \pm 2V$	300			$\Omega$		
$I_+$	Positive supply current (output open)	$V_{IN} = 1.9V$	$V_+ = 9.0V, V_- = -9.0V$ $V_+ = 12V, V_- = -12V$ $V_+ = 15V, V_- = -15V$		15.0 19.0 25.0	20.0 25.0 34.0	mA mA mA	
			$V_{IN} = 0.8V$	$V_+ = 9.0V, V_- = -9.0V$ $V_+ = 12V, V_- = -12V$ $V_+ = 15V, V_- = -15V$		4.5 5.5 8.0	6.0 7.0 12.0	mA mA mA
$I_-$	Negative supply current (output open)	$V_{IN} = 1.9V$	$V_+ = 9.0V, V_- = -9.0V$ $V_+ = 12V, V_- = -12V$ $V_+ = 15V, V_- = -15V$		-13.0 -18.0 -25.0	-17.0 -23.0 -34.0	mA mA mA	
			$V_{IN} = 0.8V$	$V_+ = 9.0V, V_- = -9.0V$ $V_+ = 12V, V_- = -12V$ $V_+ = 15V, V_- = -15V$		-1 -1 -0.01	-15 -15 -2.5	$\mu\text{A}$ $\mu\text{A}$ mA
$P_D$	Maximum power dissipation, $T_A = 25^\circ\text{C}$ (still-air) <sup>2</sup> F package N package D package					1190 1420 1040	mW mW mW	
		$t_{PD1}$	Propagation delay to "1"	$R_L = 3.0k\Omega, C_L = 15pF, T_A = 25^\circ\text{C}$		275	560	ns
		$t_{PD0}$	Propagation delay to "0"	$R_L = 3.0k\Omega, C_L = 15pF, T_A = 25^\circ\text{C}$		70	175	ns
$t_R$	Rise time	$R_L = 3.0k\Omega, C_L = 15pF, T_A = 25^\circ\text{C}$		75	100	ns		
$t_F$	Fall time	$R_L = 3.0k\Omega, C_L = 15pF, T_A = 25^\circ\text{C}$		40	75	ns		

**NOTES:**

- Voltage values shown are with respect to network ground terminal. Positive current is defined as current into the referenced pin.
- Derate above  $25^\circ\text{C}$ , at the following rates:
  - F package at  $9.5\text{mW}/^\circ\text{C}$ .
  - N package at  $11.4\text{mW}/^\circ\text{C}$ .
  - D package at  $8.3\text{mW}/^\circ\text{C}$ .

# Quad line driver

# MC1488

## TYPICAL PERFORMANCE CHARACTERISTICS

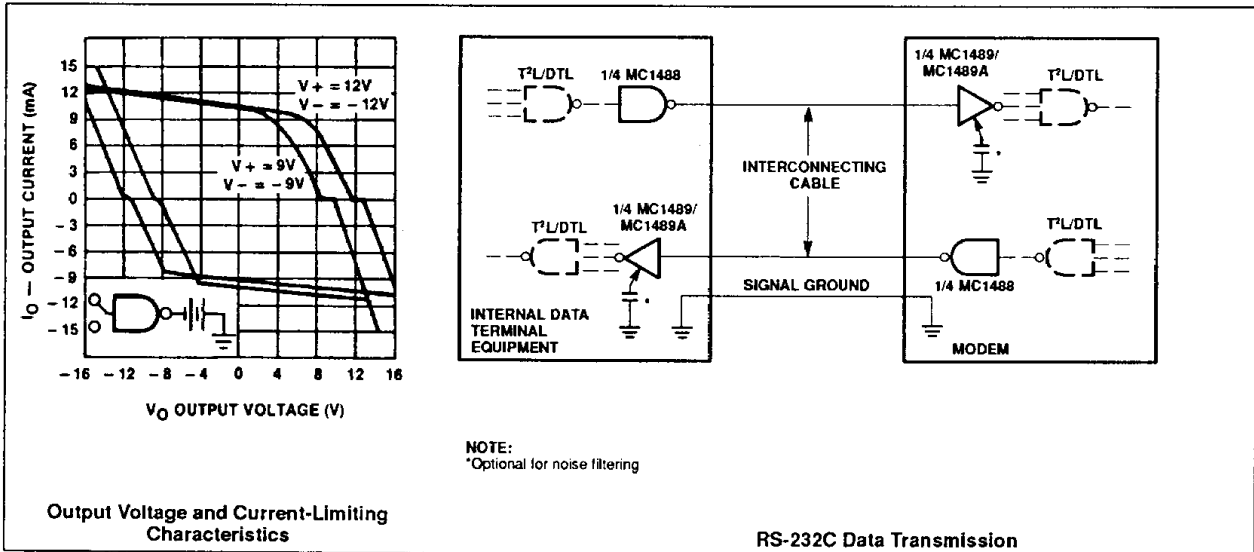

## AC LOAD CIRCUIT

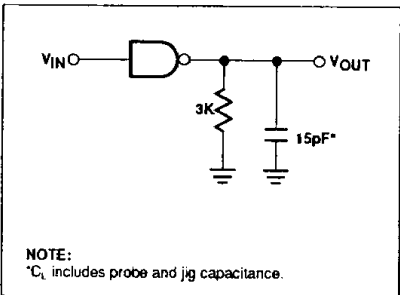

## APPLICATIONS

By connecting a capacitor to each driver output the slew rate can be controlled utilizing the output current-limiting characteristics of the MC1488. For a set slew rate the appropriate capacitor value may be calculated using the following relationship

$$C = I_{SC}(\Delta T/\Delta V)$$

where C is the required capacitor, I<sub>SC</sub> is the short-circuit current value, and ΔV/ΔT is the slew rate.

RS-232C specifies that the output slew rate must not exceed 30V/μs. Using the worst-case output short-circuit current of 12mA in the above equation, calculations result in a required capacitor of 400pF connected to each output.

## SWITCHING WAVEFORMS

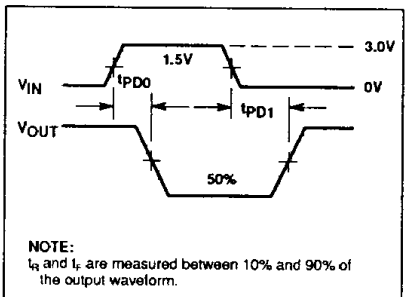

## TYPICAL APPLICATIONS

