

TZA3050

30 Mbits/s up to 1.25 Gbits/s burst mode laser driver

Rev. 03 — 7 April 2005

Product data sheet

1. General description

The TZA3050 is a fully integrated laser driver for burst mode optical transmission systems with data rates up to 1.25 Gbits/s. The TZA3050 incorporates all necessary control and protection functions for a laser driver application with very few external components required and low power dissipation. The average-loop controls the average monitor current in a typical programmable range from 150 μ A to 1300 μ A. The average-loop settings are memorized internally between bursts of data. The bias and modulation currents have a fast switch on and off time of less than 100 ns.

The design is made in the Philips BiCMOS RF process and is available in a HBCC32 package. The TZA3050 is intended for use in an application with a DC-coupled laser diode for both 3.3 V and 5 V laser supply voltages.

The BIAS output is optimized for low voltage requirements giving a minimum of 1.25 V for 3.3 V and 5 V laser supplies.

2. Features

2.1 General

- Burst mode laser driver from 30 Mbits/s to 1.25 Gbits/s
- Bias current from 10 mA up to 100 mA
- Modulation current from 6 mA up to 100 mA
- Switch on and off time for bias and modulation currents below 100 ns
- Integrated burst mode switching and memory circuit
- Rise and fall times typically 120 ps
- Jitter below 30 ps peak-to-peak value
- Retiming function via external clock with disable option
- Pulse width adjustment function with disable option
- Positive Emitter Coupled Logic (PECL), Low Voltage Positive Emitter Coupled Logic (LVPECL) and Current Mode Logic (CML) compatible data and clock inputs
- Internal common mode voltage available for AC-coupled data and clock inputs and for single-ended applications
- 3.3 V supply voltage
- DC-coupled laser for 3.3 V and 5 V laser supply

PHILIPS

2.2 Control

- Average power loop control
- Optional direct setting of bias current
- Direct setting of modulation current

2.3 Protection

- Alarm function on operating current
- Alarm function on monitor current
- Soft start-up on bias and modulation currents during power-up

3. Applications

- Burst mode laser driver

4. Ordering information

Table 1: Ordering information

Type number	Package		
	Name	Description	Version
TZA3050VH	HBCC32	plastic thermal enhanced bottom chip carrier; 32 terminals; body 5 × 5 × 0.65 mm	SOT560-1

5. Block diagram

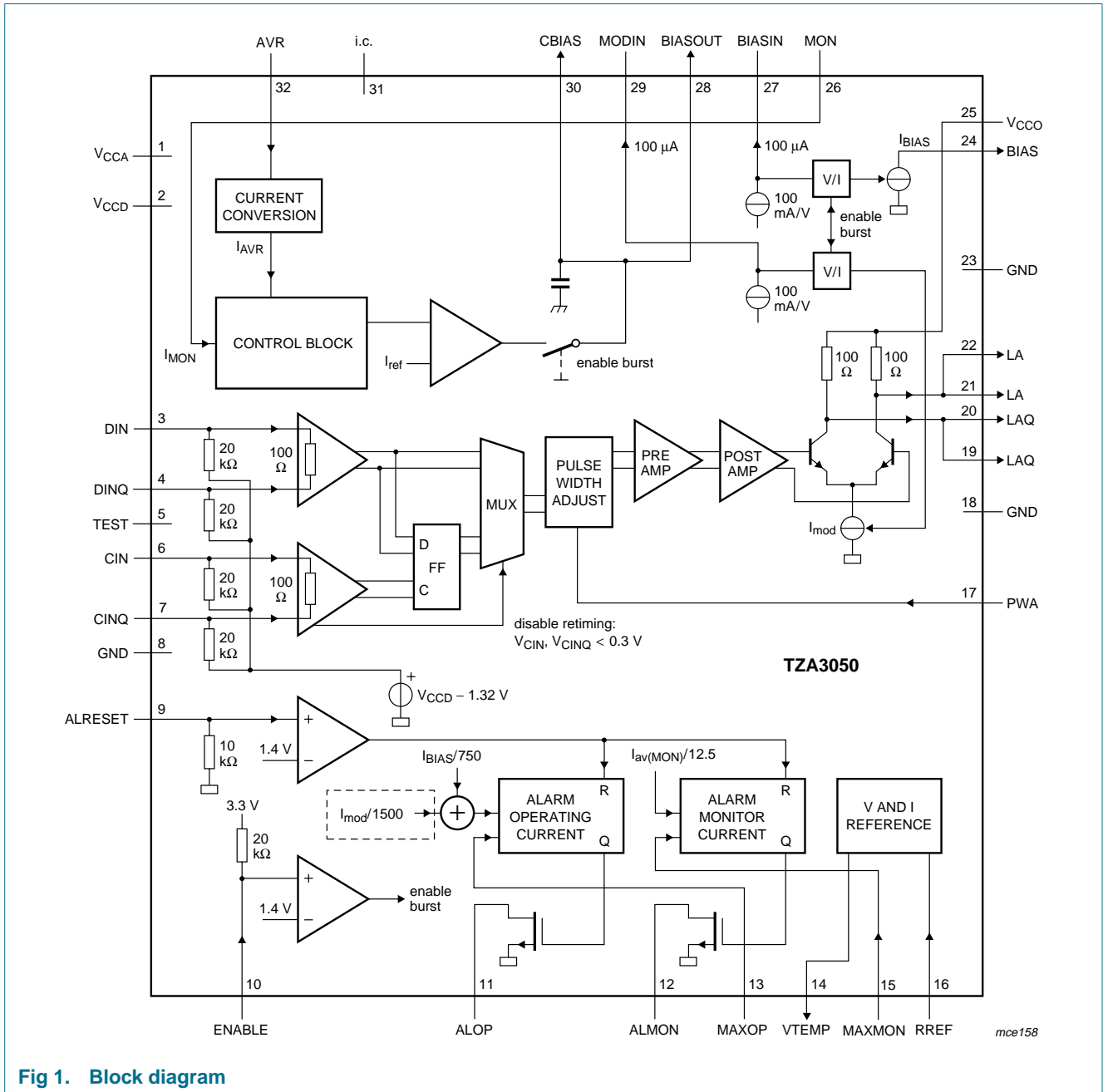
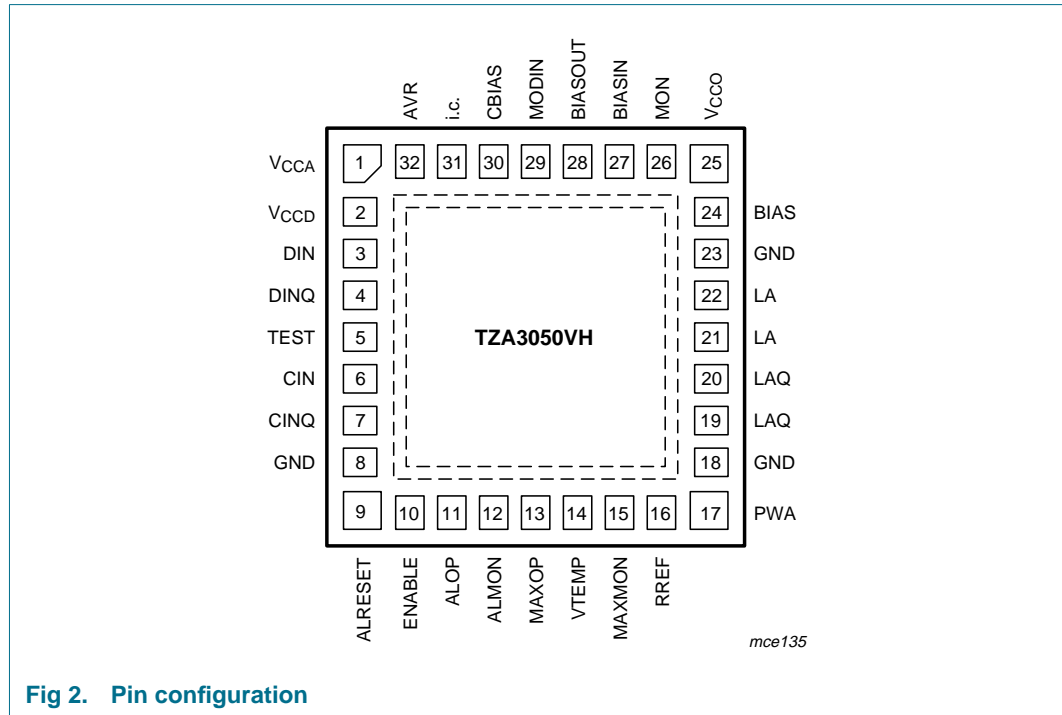

Fig 1. Block diagram

6. Pinning information

6.1 Pinning



6.2 Pin description

Table 2: Pin description

Symbol	Pin	Description
GND	die pad	common ground plane for V_{CCA} , V_{CCD} , V_{CCO} , RF and I/O; must be connected to ground
V_{CCA}	1	analog supply voltage
V_{CCD}	2	digital supply voltage
DIN	3	non-inverted data input (RF input)
DINQ	4	inverted data input (RF input)
TEST	5	test pin; must be connected to ground
CIN	6	non-inverted clock input (RF input)
CINQ	7	inverted clock input (RF input)
GND	8	ground
ALRESET	9	alarm reset input for alarm outputs ALMON and ALOP
ENABLE	10	enable input for modulation and bias current switch on and off between bursts
ALOP	11	alarm output on operating current (open-drain)
ALMON	12	alarm output on monitor diode current (open-drain)
MAXOP	13	threshold level input for alarm on operating current
VTEMP	14	temperature dependent voltage output

Table 2: Pin description ...continued

Symbol	Pin	Description
MAXMON	15	threshold level input for alarm on monitor diode current
RREF	16	reference current input; must be connected to ground with an accurate (1 %) 10 kΩ resistor
PWA	17	pulse width adjustment input
GND	18	ground
LAQ	19	inverted laser modulation output (RF output); output for dummy load
LAQ	20	inverted laser modulation output (RF output); output for dummy load
LA	21	non-inverted laser modulation output (RF output); output for laser
LA	22	non-inverted laser modulation output (RF output); output for laser
GND	23	ground
BIAS	24	current source output for the laser bias current
V _{CCO}	25	supply voltage for the output stage and the laser diode
MON	26	input from the monitor photodiode (RF input)
BIASIN	27	input for the bias current setting
BIASOUT	28	output of the control block for the bias current
MODIN	29	input for the modulation current setting
CBIAS	30	output of the average loop; must be connected via a 100 nF external capacitor to GND
i.c.	31	internally connected
AVR	32	input for the optical average power level setting

7. Functional description

7.1 Data and clock input

The TZA3050 operates with differential Positive Emitter Coupled Logic (PECL), Low Voltage Positive Emitter Coupled Logic (LVPECL) and Current Mode Logic (CML) data and clock inputs with a voltage swing from 100 mV to 1 V (p-p). It is assumed that both data and clock inputs carry a complementary signal with the specified peak-to-peak value (true differential excitation).

The circuit generates an internal common mode voltage for AC-coupled data inputs, clock inputs and single-ended applications.

If $V_{DIN} > V_{DINQ}$, the modulation current is sunk by pin LA and corresponds to an optical 'one' level of the laser.

7.2 Retiming

The retiming function synchronizes the data with the clock to improve the jitter performance. The data latch switches on the rising edge of the clock input. The retiming function is disabled when both clock inputs are below 0.3 V.

At start-up the initial polarity of the laser is unknown until the first rising edge of the clock input appears.

7.3 Pulse width adjustment

The on-duration of the laser current can be adjusted with a guaranteed range from -50 ps to $+50$ ps. The adjustment time is set by connecting a resistor, R_{PWA} , to pin PWA. The maximum allowable capacitive load on pin PWA is 100 pF. Pulse width adjustment is disabled when pin PWA is short-circuited to ground.

7.4 Modulator output stage

The output stage is a high-speed bipolar differential pair with typical rise and fall times of 120 ps and with a modulation current source of up to 100 mA. The output stage of the TZA3050 is optimized for DC-coupled lasers.

The modulation current switches between the LA and LAQ outputs. For a good RF performance the inactive branch carries a small amount of the modulation current.

The LA output is optimized for the laser, the LAQ output is optimized for the dummy load.

The BIAS output is optimized for low voltage requirements (1.25 V minimum).

7.5 Average loop control

The average power control loop maintains a constant average power level of the monitor current over temperature and lifetime of the laser. The average monitor current is programmable over a wide current range, from 150 μ A to 1300 μ A typical, by tuning the setting resistor R_{AVR} . The maximum allowable capacitive load on pins AVR and BIASOUT is 100 pF.

7.6 Direct current setting

The TZA3050 can also operate in open-loop mode with direct setting of the bias and modulation currents. The bias and modulation current sources are transconductance amplifiers and the output currents are determined by the BIASIN and MODIN voltages respectively. The bias current source has a bipolar output stage with minimum output capacitance for optimum RF performance.

7.7 Soft start

At power-up the bias and modulation current sources are released when $V_{CCA} > 2.7$ V, the reference voltage has reached the correct value of 1.2 V and the voltage on pin ENABLE is HIGH.

The control loop starts with minimum bias and modulation current at power-up provided the device is enabled. The current levels increase until the input current on pin MON matches the programmed average level.

7.8 Burst mode

The TZA3050 is compliant with burst mode application. Fast switch on and off of bias and modulation currents is allowed in less than 100 ns via pin ENABLE.

When internal average loop control is used, the average power settings can be maintained between two bursts of data via an external capacitor on pin CBIAS.

During a burst, this capacitor defines the time constant of the loop. Between bursts, the capacitor is automatically disconnected from the internal circuitry and is used as a memory cell.

A more complex memory cell can also be connected to pin CBIAS.

7.9 Alarm functions

The TZA3050 features two alarm functions for the detection of excessive laser operating current and monitor diode current due to laser ageing, laser malfunctioning or a high laser temperature. The alarm threshold levels are programmed by a resistor or a current source. The operating current equals the bias current plus half of the modulation current.

7.10 Enable

A LOW level on the enable input disables the bias and modulation current sources: the laser is off. A HIGH level on the enable input or an open enable input switches both current sources on: the laser is operational.

7.11 Reference block

The reference voltage is derived from a band gap circuit and is available at pin RREF. An accurate (1 %) 10 k Ω resistor has to be connected to pin RREF to provide the internal reference current. The maximum allowable capacitive load on pin RREF is 100 pF.

The reference voltage on the setting pins MAXOP, MAXMON, PWA and AVR is buffered and derived from the band gap voltage.

The output voltage on pin VTEMP reflects the junction temperature of the TZA3050. The temperature coefficient of V_{VTEMP} equals -2.2 mV/K.

8. Limiting values

Table 3: Limiting values

In accordance with the Absolute Maximum Rating System (IEC 60134).
All voltages are referenced to ground; positive currents flow into the IC.

Symbol	Parameter	Conditions	Min	Max	Unit
V_{CCD}	digital supply voltage		-0.5	+3.5	V
V_{CCA}	analog supply voltage		-0.5	+3.5	V
V_{CCO}	RF output supply voltage	3.3 V laser supply	-0.5	+3.5	V
		5 V laser supply	-0.5	+5.3	V
$V_{o(LA)}$	output voltage at pin LA	$V_{CCO} = 3.3$ V	0.8	4.1	V
		$V_{CCO} = 5$ V	1.2	4.5	V
$V_{o(LAQ)}$	output voltage at pin LAQ	$V_{CCO} = 3.3$ V	1.6	4.5	V
		$V_{CCO} = 5$ V	2.0	5.2	V
V_{BIAS}	bias voltage	$V_{CCO} = 3.3$ V	0.8	3.6	V
		$V_{CCO} = 5$ V	0.8	4.1	V
V_n	voltage on all other input and output pins				
	analog inputs and outputs		-0.5	$V_{CCA} + 0.5$	V
	digital inputs and outputs		-0.5	$V_{CCD} + 0.5$	V
I_n	input current on pins				
	MAXOP, MAXMON, RREF, PWA and AVR		-1.0	0	mA
	VTEMP and BIASOUT		-1.0	+1.0	mA
	ALOP, ALMON and MON		0	5.0	mA
T_{amb}	ambient temperature		-40	+85	°C
T_j	junction temperature		-40	+125	°C
T_{stg}	storage temperature		-65	+150	°C

9. Thermal characteristics

Table 4: Thermal characteristics

In compliance with JEDEC standards JESD51-5 and JESD51-7.

Symbol	Parameter	Conditions	Typ	Unit
$R_{th(j-a)}$	thermal resistance from junction to ambient	4 layer printed-circuit board in still air with 9 plated vias connected with the heatsink and the first ground plane in the PCB	35	K/W
		HBCC32 die pad soldered to PCB	60	K/W

10. Static characteristics

Table 5: Static characteristics

$T_{amb} = -40\text{ }^{\circ}\text{C}$ to $+85\text{ }^{\circ}\text{C}$; $R_{th(j-a)} = 35\text{ K/W}$; $P_{tot} = 400\text{ mW}$; $V_{CCA} = 3.14\text{ V}$ to 3.47 V ; $V_{CCD} = 3.14\text{ V}$ to 3.47 V ; $V_{CCO} = 3.14\text{ V}$ to 3.47 V ; $R_{AVR} = 7.5\text{ k}\Omega$; $R_{MODIN} = 6.2\text{ k}\Omega$; $R_{BIASIN} = 6.8\text{ k}\Omega$; $R_{PWA} = 10\text{ k}\Omega$; $R_{RREF} = 10\text{ k}\Omega$ (1 %); $R_{MAXMON} = 13\text{ k}\Omega$; $R_{MAXOP} = 20\text{ k}\Omega$; positive currents flow into the IC; all voltages are referenced to ground; unless otherwise specified.

Symbol	Parameter	Conditions	Min	Typ	Max	Unit	
Supplies: pins V_{CCA}, V_{CCD} and V_{CCO}							
V _{CCA}	analog supply voltage		3.14	3.3	3.47	V	
V _{CCD}	digital supply voltage		3.14	3.3	3.47	V	
V _{CCO}	RF output supply voltage	3.3 V laser supply	3.14	3.3	3.47	V	
		5 V laser supply	4.75	5.0	5.25	V	
I _{CCA}	analog supply current		-	40	55	mA	
I _{CCD}	digital supply current		-	45	60	mA	
I _{CCO}	RF output supply current	pins LA and LAQ open-circuit; 3.3 V and 5 V laser supply	-	20	30	mA	
P _{tot}	total power dissipation	V _{BIAS} = 3.3 V; I _{mod} = 16 mA; I _{BIAS} = 20 mA	[1]	-	412	-	mW
P _{core}	core power dissipation	excluding I _{o(LA)} , I _{o(LAQ)} and I _{BIAS} ; PWA and retiming off	-	264	-	mW	
Data and clock inputs: pins DIN and CIN							
V _{i(p-p)}	input voltage swing (peak-to-peak value)	V _{i(DIN)} = V _{CCD} - 2 V to V _{CCD} ; V _{i(CIN)} = V _{CCD} - 2 V to V _{CCD}	100	-	1000	mV	
V _{int(cm)}	internal common mode voltage	AC-coupled inputs	-	V _{CCD} - 1.32	-	V	
V _{IO}	input offset voltage		[2]	-10	0	+10	mV
Z _{i(dif)}	differential input impedance		80	100	130	Ω	
Z _{i(cm)}	common mode input impedance		-	10	-	k Ω	
V _{i(CIN)(dis)}	input voltage for disabled retiming	V _{CIN} = V _{CINQ}	-	-	0.3	V	
Monitor photodiode input: pin MON							
V _{i(MON)}	input voltage	I _{av} = 150 μ A to 1300 μ A	0.9	1.1	1.3	V	
Z _{i(MON)}	input impedance	I _{av} = 150 μ A to 1300 μ A	-	27	-	Ω	
Setting for average loop control: pins MON and AVR							
I _{av(MON)(low)}	low average monitor current setting	I _{AVR} > -250 μ A	-	-	150	μ A	
I _{av(MON)(max)}	maximum average monitor current setting	I _{AVR} = -50 μ A	1150	1300	-	μ A	
$\Delta I_{av(MON)}$	relative accuracy of average current on pin MON	temperature and V _{CCA} variations; I _{AVR} = 550 μ A	-10	-	+10	%	
V _{ref(AVR)}	reference voltage on pin AVR	I _{AVR} = -250 μ A to -15 μ A; C _{AVR} < 100 pF	1.14	1.20	1.26	V	
I _{sink(AVR)}	current sink on pin AVR		-280	-	-15	μ A	

Table 5: Static characteristics ...continued

$T_{amb} = -40\text{ }^{\circ}\text{C}$ to $+85\text{ }^{\circ}\text{C}$; $R_{th(j-a)} = 35\text{ K/W}$; $P_{tot} = 400\text{ mW}$; $V_{CCA} = 3.14\text{ V}$ to 3.47 V ; $V_{CCD} = 3.14\text{ V}$ to 3.47 V ; $V_{CCO} = 3.14\text{ V}$ to 3.47 V ; $R_{AVR} = 7.5\text{ k}\Omega$; $R_{MODIN} = 6.2\text{ k}\Omega$; $R_{BIASIN} = 6.8\text{ k}\Omega$; $R_{PWA} = 10\text{ k}\Omega$; $R_{RREF} = 10\text{ k}\Omega$ (1 %); $R_{MAXMON} = 13\text{ k}\Omega$; $R_{MAXOP} = 20\text{ k}\Omega$; positive currents flow into the IC; all voltages are referenced to ground; unless otherwise specified.

Symbol	Parameter	Conditions	Min	Typ	Max	Unit
Control loop bias output: pin BIASOUT						
$I_{source(BIASOUT)}$	source current	$V_{BIASOUT} = 0.5\text{ V}$ to 1.5 V ; $C_{BIASOUT} < 100\text{ pF}$	-	-	-200	μA
$I_{sink(BIASOUT)}$	sink current	$V_{BIASOUT} = 0.5\text{ V}$ to 1.5 V ; $C_{BIASOUT} < 100\text{ pF}$	200	-	-	μA
Bias current source: pins BIASIN and BIAS						
$g_m(\text{bias})$	bias transconductance	$V_{BIASIN} = 0.5\text{ V}$ to 1.5 V ; $V_{BIAS} = V_{CCO}$	89	110	131	mA/V
$I_{source(BIASIN)}$	source current at pin BIASIN	$V_{BIASIN} = 0.5\text{ V}$ to 1.5 V	-110	-100	-95	μA
$I_{BIAS(\text{max})}$	maximum bias current	$V_{BIASIN} = 1.8\text{ V}$	100	-	-	mA
$I_{BIAS(\text{min})}$	minimum bias current	$V_{BIASIN} = 0\text{ V}$ to 0.4 V	-	0.2	0.4	mA
$I_{BIAS(\text{dis})}$	bias current at disable	$V_{ENABLE} < 0.8\text{ V}$	-	-	100	μA
$V_{o(BIAS)}$	output voltage on pin BIAS		1.25	-	-	V
Modulation current source: pin MODIN						
$g_m(\text{mod})$	modulation transconductance	$V_{MODIN} = 0.5\text{ V}$ to 1.5 V ; $V_{LA} = V_{LAQ} = V_{CCO}$	77	95	112	mA/V
$I_{source(MODIN)}$	source current at pin MODIN	$V_{MODIN} = 0.5\text{ V}$ to 1.5 V	-110	-100	-95	μA
Modulation current outputs: pins LA and LAQ						
$I_{o(LA)(\text{max})(\text{on})}$	maximum laser modulation output current at LA on	$V_{MODIN} = 1.8\text{ V}$; $V_{LA} = V_{CCO} = 3.3\text{ V}$	[3] 100	-	-	mA
$I_{o(LA)(\text{min})(\text{on})}$	minimum laser modulation output current at LA on	$V_{MODIN} = 0\text{ V}$ to 0.4 V ; $V_{LA} = V_{CCO} = 3.3\text{ V}$	[3] -	5	6	mA
$I_{o(LA)(\text{min})(\text{off})}$	minimum laser modulation output current at LA off	$V_{MODIN} = 1.5\text{ V}$; $V_{LA} = V_{CCO} = 3.3\text{ V}$	[3] -	-	2	mA
$Z_{o(LA)}, Z_{o(LAQ)}$	output impedance LA and LAQ pins		80	100	130	Ω
$I_{o(LA)(\text{dis})}, I_{o(LAQ)(\text{dis})}$	non-inverted and inverted laser modulation output current at disable	$V_{ENABLE} < 0.8\text{ V}$	-	-	200	μA
$V_{o(LA)(\text{min})}$	minimum output voltage at pin LA	$V_{CCO} = 3.3\text{ V}$ $V_{CCO} = 5\text{ V}$	1.2 1.6	- -	- -	V V
Enable function: pin ENABLE						
V_{IL}	LOW-level input voltage	bias and modulation currents disabled	-	-	0.8	V
V_{IH}	HIGH-level input voltage	bias and modulation currents enabled	2.0	-	-	V

Table 5: Static characteristics ...continued

$T_{amb} = -40\text{ °C to }+85\text{ °C}$; $R_{th(j-a)} = 35\text{ K/W}$; $P_{tot} = 400\text{ mW}$; $V_{CCA} = 3.14\text{ V to }3.47\text{ V}$; $V_{CCD} = 3.14\text{ V to }3.47\text{ V}$; $V_{CCO} = 3.14\text{ V to }3.47\text{ V}$; $R_{AVR} = 7.5\text{ k}\Omega$; $R_{MODIN} = 6.2\text{ k}\Omega$; $R_{BIASIN} = 6.8\text{ k}\Omega$; $R_{PWA} = 10\text{ k}\Omega$; $R_{RREF} = 10\text{ k}\Omega$ (1 %); $R_{MAXMON} = 13\text{ k}\Omega$; $R_{MAXOP} = 20\text{ k}\Omega$; positive currents flow into the IC; all voltages are referenced to ground; unless otherwise specified.

Symbol	Parameter	Conditions	Min	Typ	Max	Unit
$R_{pu(int)}$	internal pull-up resistance		-	20	-	k Ω

Alarm reset: pin ALRESET

V_{IL}	LOW-level input voltage	no reset	-	-	0.8	V
V_{IH}	HIGH-level input voltage	reset	2.0	-	-	V
$R_{pd(int)}$	internal pull-down resistance		-	10	-	k Ω

Alarm operating current: pins MAXOP and ALOP

$V_{ref(MAXOP)}$	reference voltage on pin MAXOP	$I_{MAXOP} = 10\text{ }\mu\text{A to }200\text{ }\mu\text{A}$	1.15	1.2	1.25	V
N_{MAXOP}	ratio of $I_{oper(alarm)}$ and I_{MAXOP}	$I_{oper(alarm)} = 7.5\text{ mA to }150\text{ mA}$	-	775	-	
$V_{D(ALOP)L}$	drain voltage at active alarm	$I_{ALOP} = 500\text{ }\mu\text{A}$	0	-	0.4	V

Alarm monitor current: pins MAXMON and ALMON

$V_{ref(MAXMON)}$	reference voltage on pin MAXMON	$I_{MAXMON} = 10\text{ }\mu\text{A to }200\text{ }\mu\text{A}$	1.15	1.2	1.25	V
N_{MAXMON}	ratio of $I_{MON(alarm)}$ and I_{MAXMON}	$I_{MON(alarm)} = 150\text{ }\mu\text{A to }3000\text{ }\mu\text{A}$	-	15	-	
$V_{D(ALMON)L}$	drain voltage at active alarm	$I_{ALMON} = 500\text{ }\mu\text{A}$	0	-	0.4	V

Reference block: pins RREF and VTEMP

V_{RREF}	reference voltage	$R_{RREF} = 10\text{ k}\Omega$ (1%); $C_{RREF} < 100\text{ pF}$	1.15	1.20	1.25	V
V_{VTEMP}	temperature dependent voltage	$T_j = 25\text{ °C}$; $C_{VTEMP} < 2\text{ nF}$	[4] 1.14	1.20	1.27	V
TC_{VTEMP}	temperature coefficient of V_{VTEMP}	$T_j = -25\text{ °C to }+125\text{ °C}$	[4] -	-2.2	-	mV/K
$I_{source(VTEMP)}$	source current of pin VTEMP		-	-	-1	mA
$I_{sink(VTEMP)}$	sink current of pin VTEMP		1	-	-	mA

[1] The total power dissipation P_{tot} is calculated with $V_{BIAS} = V_{CCO} = 3.3\text{ V}$ and $I_{BIAS} = 20\text{ mA}$. In the application V_{BIAS} will be V_{CCO} minus the laser diode voltage which results in a lower total power dissipation.

[2] The specification of the offset voltage is guaranteed by design.

[3] The relation between the sink current $I_{o(LA)}$ and the modulation current I_{mod} is: $I_{o(LA)} = I_{mod} \times \frac{100}{100 + Z_{L(LA)}}$ where $Z_{L(LA)}$ is the external load on pin LA. The voltage on pin MODIN programmes the modulation current I_{mod} . This current is divided between $Z_{L(LA)}$ and the $100\text{ }\Omega$ internal resistor connected to pins LA. When the modulation current is programmed to 100 mA , a typical $Z_{L(LA)}$ of $25\text{ }\Omega$ will result in an $I_{o(LA)}$ current of 80 mA , while 20 mA flows via the internal resistor. This corresponds to a voltage swing of 2 V on the real application load.

[4] $V_{VTEMP} = 1.31 + TC_{VTEMP} \times T_j$ and $T_j = T_{amb} + P_{tot} \times R_{th(j-a)}$

11. Dynamic characteristics

Table 6: Dynamic characteristics

$T_{amb} = -40\text{ }^{\circ}\text{C}$ to $+85\text{ }^{\circ}\text{C}$; $R_{th(j-a)} = 35\text{ K/W}$; $P_{tot} = 420\text{ mW}$; $V_{CCA} = 3.14\text{ V}$ to 3.47 V ; $V_{CCD} = 3.14\text{ V}$ to 3.47 V ; $V_{CCO} = 3.14\text{ V}$ to 3.47 V ; $R_{AVR} = 7.5\text{ k}\Omega$; $R_{MODIN} = 6.2\text{ k}\Omega$; $R_{BIASIN} = 6.8\text{ k}\Omega$; $R_{PWA} = 10\text{ k}\Omega$; $R_{RREF} = 10\text{ k}\Omega$ (1%); $R_{MAXMON} = 13\text{ k}\Omega$; $R_{MAXOP} = 20\text{ k}\Omega$; positive currents flow into the IC; all voltages are referenced to ground; unless otherwise specified.

Symbol	Parameter	Conditions	Min	Typ	Max	Unit
RF path						
BR	bit rate	average loop control	0.03	-	1.25	Gbits/s
$J_{(LA)(p-p)}$	jitter of pin LA output signal (peak-to-peak value)	$R_L = 25\ \Omega$	-	-	30	ps
t_r, t_f	rise and fall time of voltage on pin LA	20 % to 80 %; $R_L = 25\ \Omega$; $I_{mod} = 30\text{ mA}$	-	120	150	ps
$t_{su(D)}$	data input set-up time		60	-	-	ps
$t_{h(D)}$	data input hold time		60	-	-	ps
$t_{o(en)}$	switch-on time at enable	from 50 % of enable to 90 % of steady state typical bias and modulation current	[1] -	-	100	ns
$t_{o(dis)}$	switch-off time at disable	from 50 % of enable to 10 % of steady state typical bias and modulation current	[1] -	-	100	ns
Current control						
$t_{c(int)}$	average loop time constant	average loop control; $C_{CBIAS} = 100\text{ nF}$	-	5	-	ms
$t_{burst(min)}$	minimum burst time	ENABLE pin HIGH	30	-	-	μs
$t_{idle(max)}$	maximum time between two bursts	ENABLE pin LOW	-	-	8	ms
Pulse width adjustment						
$t_{PWA(min)}$	minimum pulse width adjustment on pins LA	$R_{PWA} = 6.7\text{ k}\Omega$; $C_{PWA} < 100\text{ pF}$	-	-100	-50	ps
t_{PWA}	pulse width adjustment on pins LA	$R_{PWA} = 10\text{ k}\Omega$; $C_{PWA} < 100\text{ pF}$	-	0	-	ps
$t_{PWA(max)}$	maximum pulse width adjustment on pins LA	$R_{PWA} = 20\text{ k}\Omega$; $C_{PWA} < 100\text{ pF}$	50	100	-	ps

[1] The switch-on and switch-off time at enable and disable given are the absolute maximum values. They depend strongly on the following parameters: bias current, modulation current, bias inductance and laser supply voltage. More detailed information available upon request.

12. Application information

12.1 Design equations

12.1.1 Bias and modulation currents

The bias and modulation currents are determined by the voltages on pins BIASIN and MODIN. For average loop control the BIASIN voltage is applied by the BIASOUT pin and the MODIN voltage is applied by an external voltage source or an external resistor R_{MODIN} .

For direct setting of bias and modulation currents, the BIASIN and MODIN voltages have to be applied by external voltage sources or by external resistors R_{BIASIN} and R_{MODIN} connected to the BIASIN and MODIN pins:

$$I_{BIAS} = (R_{BIASIN} \times 100 \mu A - 0.5 V) \times g_{m(bias)} [mA]$$

$$I_{mod} = (R_{MODIN} \times 100 \mu A - 0.5 V) \times g_{m(mod)} + 5 [mA]$$

The transconductance $g_{m(mod)}$ defines the relation between the voltage on pin MODIN and the modulation current.

The bias and modulation current sources operate with an input voltage range from 0.5 V to 1.5 V. The output current is at its minimum level for an input voltage below 0.4 V; see [Figure 3](#) and [Figure 4](#). The graphs indicate the values with a load of 0 Ω . When the load is not zero, the relation between $I_{o(LA)}$ and I_{mod} is given in [Table 5](#), [Table note 3](#).

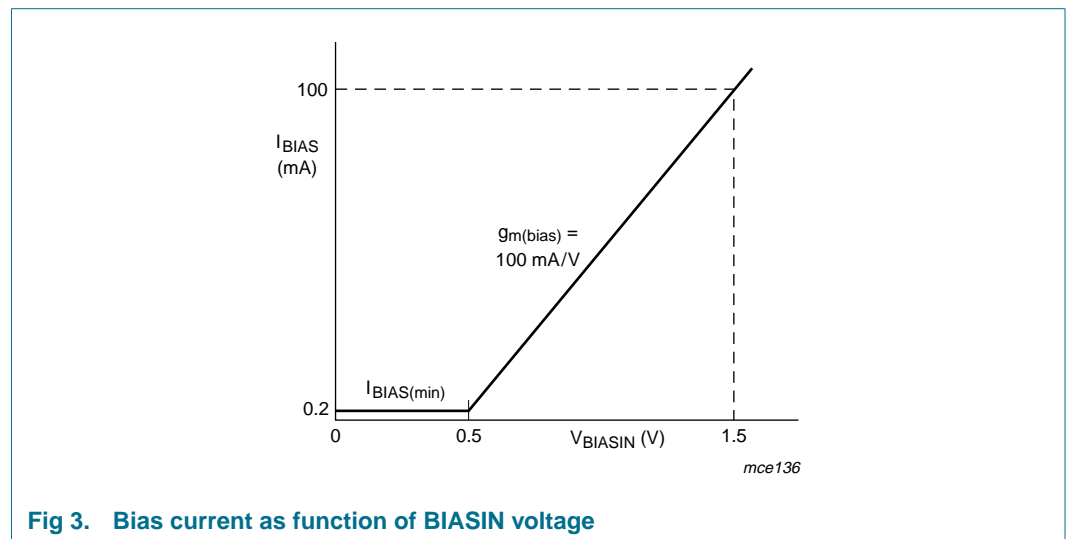

Fig 3. Bias current as function of BIASIN voltage

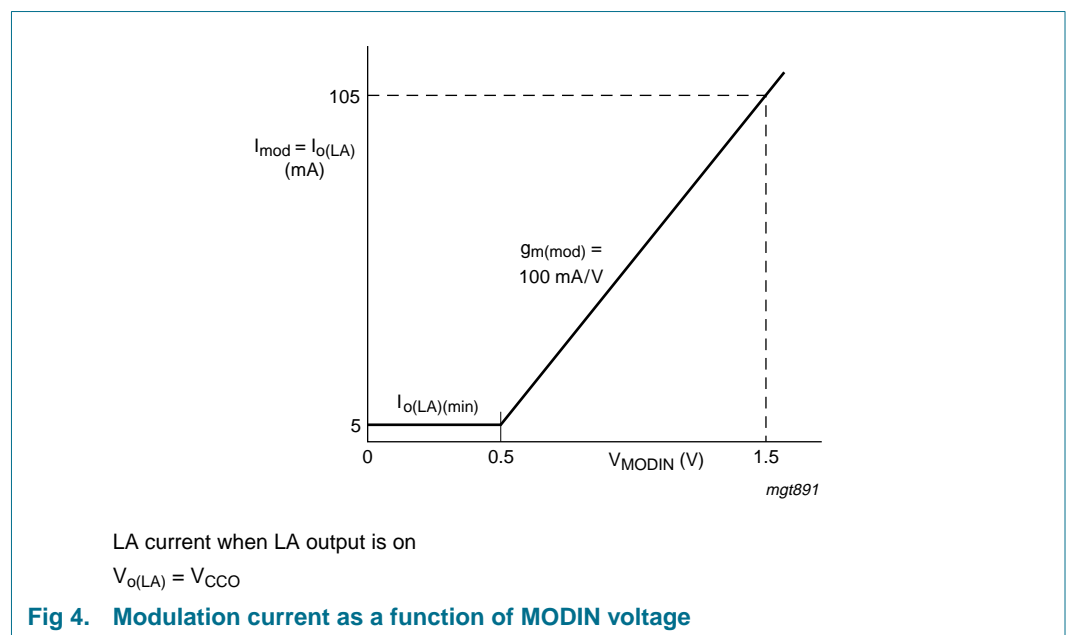

Fig 4. Modulation current as a function of MODIN voltage

12.1.2 Average monitor current

The bias and modulation current sources are temperature compensated and keep the adjusted current level stable over the temperature range.

The bias and modulation currents increase with increasing resistor values for R_{BIASIN} and R_{MODIN} respectively; this allows resistor tuning to start at a minimum current level.

The average monitor current $I_{av(MON)}$ in average loop operation is determined by the source current of the AVR pin (I_{AVR}). The current can be sunk by an external current source or by an external resistor, R_{AVR} , connected to ground. The equation is:

$$I_{av(MON)} = 1580 - 5.26 \times I_{AVR} = 1580 - 5.26 \times \frac{V_{AVR}}{R_{AVR}} \text{ [\mu A]}$$

The average monitor current increases with decreasing I_{AVR} or increasing R_{AVR} ; this allows resistor tuning of R_{AVR} to start at a minimum I_{AVR} current level (Figure 5).

The formula used to program AVR is valid for typical conditions; tuning is necessary to achieve absolute accuracy of the AVR value.

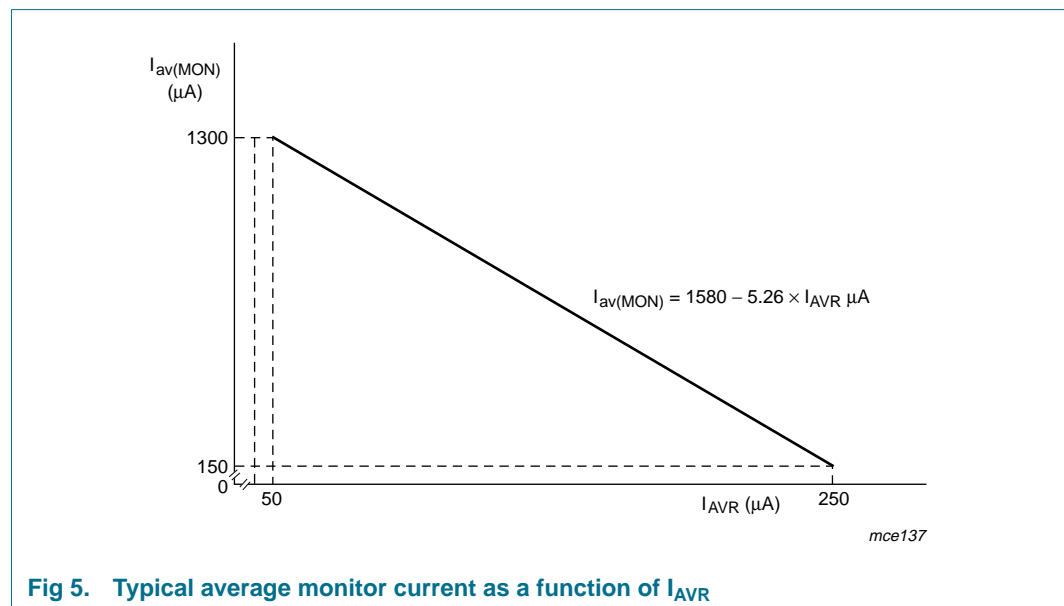

Fig 5. Typical average monitor current as a function of I_{AVR}

12.1.3 Alarm operating current

The operating current for the DC-coupled laser application equals the bias current plus half of the modulation current:

$$I_{oper} = I_{BIAS} + \frac{I_{mod}}{2}$$

The alarm threshold $I_{oper(alarm)}$ on the operating current is determined by the source current of the MAXOP pin. The current range for I_{MAXOP} is from 10 μA to 200 μA which corresponds with an $I_{oper(alarm)}$ from 7.5 mA to 150 mA.

The I_{MAXOP} current can be sunk by an external current source or by connecting R_{MAXOP} to ground:

$$I_{oper(alarm)} = N_{MAXOP} \times \frac{V_{MAXOP}}{R_{MAXOP}}$$

The detection level is independent of burst mode timing.

12.1.4 Alarm monitor current

The alarm threshold $I_{MON(alarm)}$ on the monitor current is determined by the source current of the MAXMON pin. The current range for I_{MAXMON} is from 10 μA to 200 μA , which corresponds with an $I_{MON(alarm)}$ from 150 μA to 3000 μA . The I_{MAXMON} current can be sunk by an external current source or by connecting R_{MAXMON} to ground:

$$I_{MON(alarm)} = N_{MAXMON} \times \frac{V_{MAXMON}}{R_{MAXMON}}$$

As the detected I_{MON} is an average current, the alarm threshold is a function of the burst mode timing. The formula can be used as a reference for a mode where signal is always present.

12.1.5 Pulse width adjustment

The pulse width adjustment time is determined by resistor R_{PWA} :

$$t_{PWA} = 200 \times \frac{R_{PWA} - 10 \text{ k}\Omega}{R_{PWA}} \text{ [ps]}$$

The t_{PWA} typical range is from -100 ps to +100 ps, which corresponds with an R_{PWA} resistance ranging from 6.7 k Ω minimum to 20 k Ω maximum (Figure 6). The PWA function is disabled when the PWA input is short-circuited to ground, the t_{PWA} is 0 ps for a disabled PWA function.

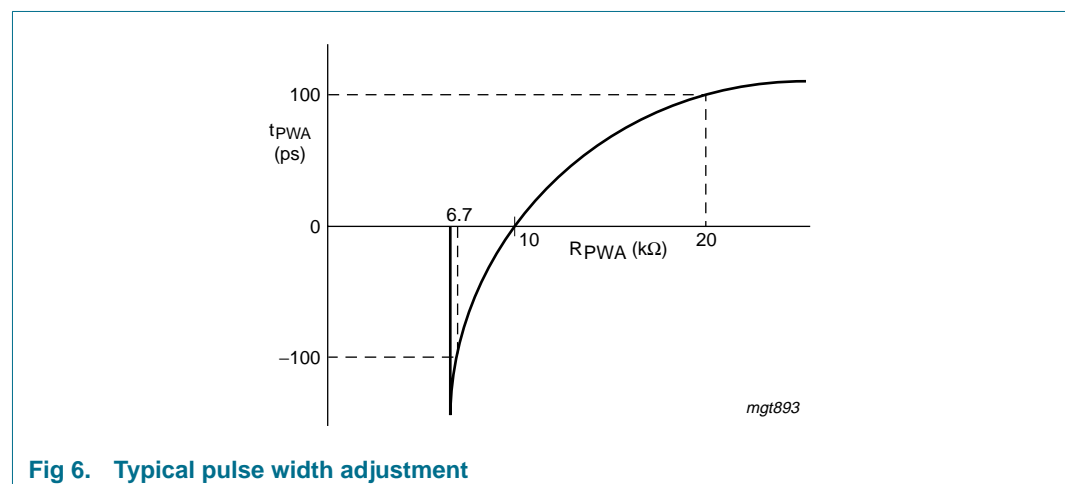

Fig 6. Typical pulse width adjustment

12.2 Burst mode application

In burst mode application, data flow is not constant, data (the 'burst') is interrupted with significant idle times when no data is present and the laser is shut-down.

When using average loop control, the control is only done during a burst of data and the average value should be stored during idle time.

The TZA3050 requires only one external capacitor to perform this storage. A typical 100 nF lossless capacitor connected to pin CBIAS will define the time constant of the loop during bursts (typical 5 ms) and will also define the accuracy of the value stored between bursts. Tuning of the external capacitor allows tuning of the average loop time constant depending on the duty cycle and the burst duration.

When pin ENABLE is LOW, an internal switch is opened and the external capacitor is connected to a high-impedance point. When pin ENABLE is HIGH, the internal switch is closed and the external capacitor is connected to the internal average loop control circuit.

The ENABLE pin also controls the on and off switch state of the bias and modulation current output stages resulting in burst-to-idle and idle-to-burst times below 100 ns on the full current range available, with a typical load of 25 Ω on pins LA and LAQ.

It is not recommended to use the TZA3050 without an external capacitor on pin CBIAS as this would result in a too small time constant, with the risk of pattern dependent behavior. [Table 7](#) shows time constants for different CBIAS capacitors.

Table 7: Typical time constant of the average loop

Capacitor C_{CBIAS}	Time constant (typ.)
10 nF	<1 ms
100 nF	5 ms
470 nF	30 ms

Using a smaller CBIAS capacitor allows a faster loop recovery in short burst period applications, but it also means a shorter storage period. A 100 nF is considered as a convenient value, even in applications with short burst time (minimum 30 μs), and large idle time (maximum 8 ms) applications as shown in [Figure 7](#).

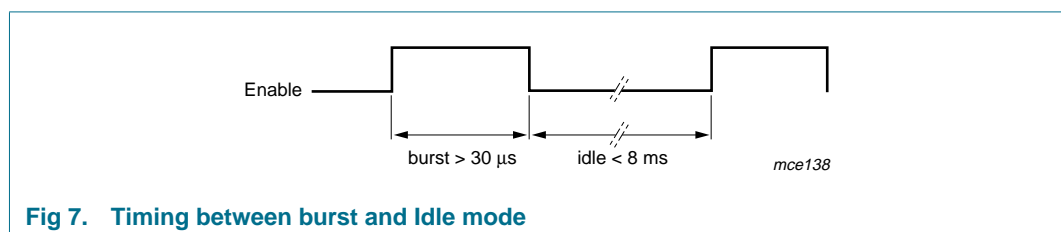

Fig 7. Timing between burst and Idle mode

At power-up, the memorized value on pin CBIAS is reset by connecting pin CBIAS internally to ground. The timing in [Figure 7](#) does not take into account the initial charging of the storage circuit. This initial timing is directly proportional to the value of the CBIAS capacitor and to the duty cycle settings of the application.

12.3 Average loop control

A simplified application using the TZA3050 with average loop control and a DC-coupled laser at 3.3 V or 5 V laser voltage is illustrated in [Figure 8](#). The average power level is determined by the resistor R_{AVR} . The average loop controls the bias current with the BIASOUT output connected to the BIASIN input. The modulation current is determined by the MODIN input voltage, which is generated by the resistor R_{MODIN} and the 100 μA source current of the MODIN pin.

The average loop setting is maintained between bursts with a capacitor connected to pin CBIAS. When pin ENABLE is HIGH, the internal average loop regulates the average power. When pin ENABLE is LOW, an internal switch is opened and the previous average loop state is stored on the CBIAS capacitor.

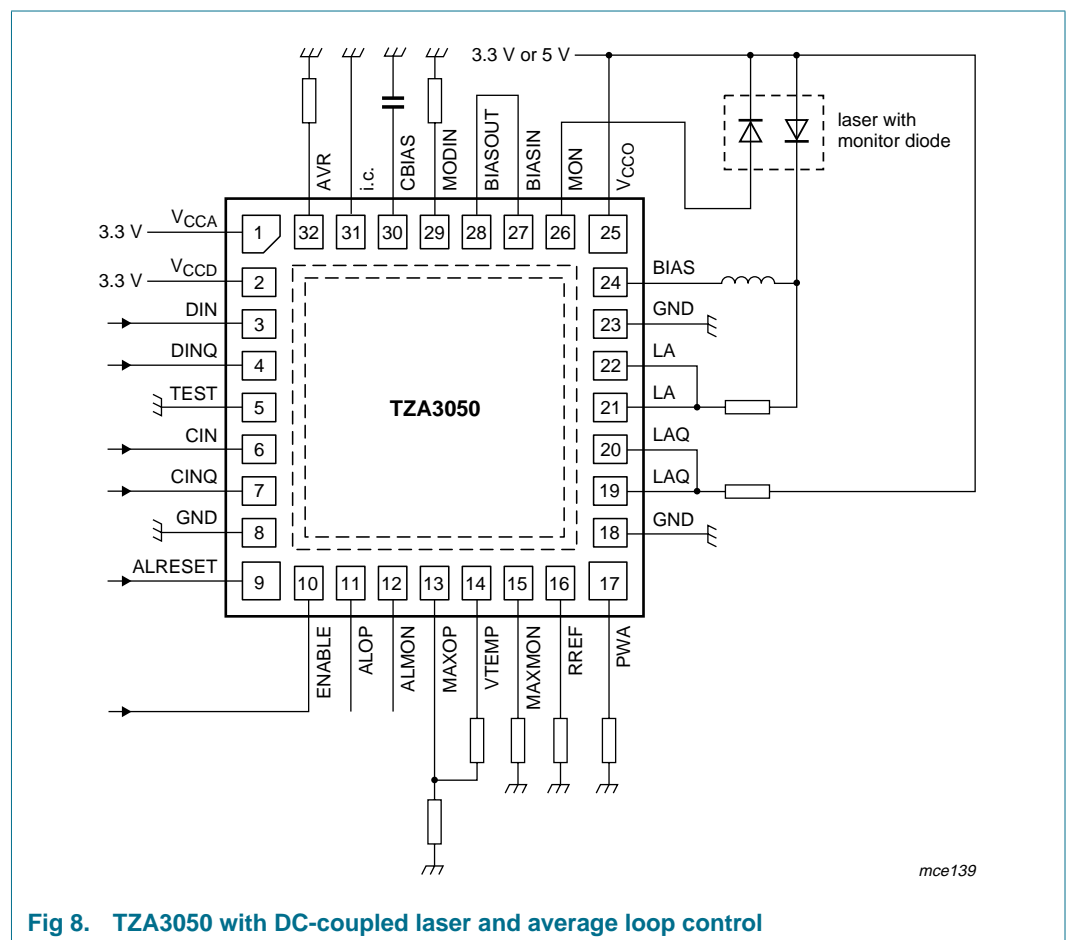

Fig 8. TZA3050 with DC-coupled laser and average loop control

13. Package outline

HBCC32: plastic thermal enhanced bottom chip carrier; 32 terminals; body 5 x 5 x 0.65 mm

SOT560-1

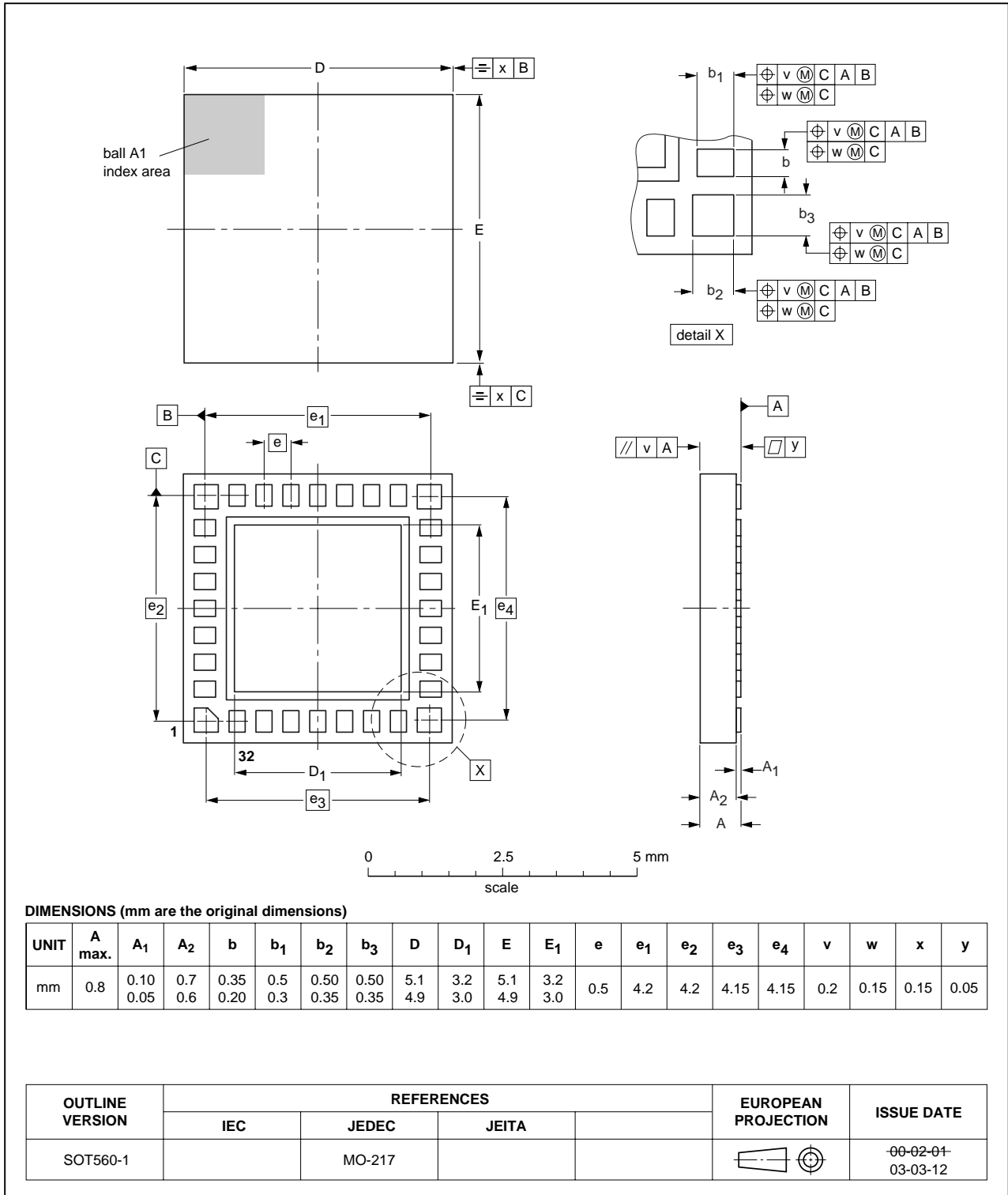

Fig 9. Package outline SOT560-1 (HBCC32)

14. Soldering

14.1 Introduction to soldering surface mount packages

This text gives a very brief insight to a complex technology. A more in-depth account of soldering ICs can be found in our *Data Handbook IC26; Integrated Circuit Packages* (document order number 9398 652 90011).

There is no soldering method that is ideal for all surface mount IC packages. Wave soldering can still be used for certain surface mount ICs, but it is not suitable for fine pitch SMDs. In these situations reflow soldering is recommended.

14.2 Reflow soldering

Reflow soldering requires solder paste (a suspension of fine solder particles, flux and binding agent) to be applied to the printed-circuit board by screen printing, stencilling or pressure-syringe dispensing before package placement. Driven by legislation and environmental forces the worldwide use of lead-free solder pastes is increasing.

Several methods exist for reflowing; for example, convection or convection/infrared heating in a conveyor type oven. Throughput times (preheating, soldering and cooling) vary between 100 seconds and 200 seconds depending on heating method.

Typical reflow peak temperatures range from 215 °C to 270 °C depending on solder paste material. The top-surface temperature of the packages should preferably be kept:

- below 225 °C (SnPb process) or below 245 °C (Pb-free process)
 - for all BGA, HTSSON..T and SSOP..T packages
 - for packages with a thickness ≥ 2.5 mm
 - for packages with a thickness < 2.5 mm and a volume ≥ 350 mm³ so called thick/large packages.
- below 240 °C (SnPb process) or below 260 °C (Pb-free process) for packages with a thickness < 2.5 mm and a volume < 350 mm³ so called small/thin packages.

Moisture sensitivity precautions, as indicated on packing, must be respected at all times.

14.3 Wave soldering

Conventional single wave soldering is not recommended for surface mount devices (SMDs) or printed-circuit boards with a high component density, as solder bridging and non-wetting can present major problems.

To overcome these problems the double-wave soldering method was specifically developed.

If wave soldering is used the following conditions must be observed for optimal results:

- Use a double-wave soldering method comprising a turbulent wave with high upward pressure followed by a smooth laminar wave.
- For packages with leads on two sides and a pitch (e):
 - larger than or equal to 1.27 mm, the footprint longitudinal axis is **preferred** to be parallel to the transport direction of the printed-circuit board;

- smaller than 1.27 mm, the footprint longitudinal axis **must** be parallel to the transport direction of the printed-circuit board.

The footprint must incorporate solder thieves at the downstream end.

- For packages with leads on four sides, the footprint must be placed at a 45° angle to the transport direction of the printed-circuit board. The footprint must incorporate solder thieves downstream and at the side corners.

During placement and before soldering, the package must be fixed with a droplet of adhesive. The adhesive can be applied by screen printing, pin transfer or syringe dispensing. The package can be soldered after the adhesive is cured.

Typical dwell time of the leads in the wave ranges from 3 seconds to 4 seconds at 250 °C or 265 °C, depending on solder material applied, SnPb or Pb-free respectively.

A mildly-activated flux will eliminate the need for removal of corrosive residues in most applications.

14.4 Manual soldering

Fix the component by first soldering two diagonally-opposite end leads. Use a low voltage (24 V or less) soldering iron applied to the flat part of the lead. Contact time must be limited to 10 seconds at up to 300 °C.

When using a dedicated tool, all other leads can be soldered in one operation within 2 seconds to 5 seconds between 270 °C and 320 °C.

14.5 Package related soldering information

Table 8: Suitability of surface mount IC packages for wave and reflow soldering methods

Package [1]	Soldering method	
	Wave	Reflow [2]
BGA, HTSSON..T [3], LBGA, LFBGA, SQFP, SSOP..T [3], TFBGA, VFBGA, XSON	not suitable	suitable
DHVQFN, HBCC, HBGA, HLQFP, HSO, HSOP, HSQFP, HSSON, HTQFP, HTSSOP, HVQFN, HVSON, SMS	not suitable [4]	suitable
PLCC [5], SO, SOJ	suitable	suitable
LQFP, QFP, TQFP	not recommended [5] [6]	suitable
SSOP, TSSOP, VSO, VSSOP	not recommended [7]	suitable
CWQCCN..L [8], PMFP [9], WQCCN..L [8]	not suitable	not suitable

[1] For more detailed information on the BGA packages refer to the *(LF)BGA Application Note (AN01026)*; order a copy from your Philips Semiconductors sales office.

[2] All surface mount (SMD) packages are moisture sensitive. Depending upon the moisture content, the maximum temperature (with respect to time) and body size of the package, there is a risk that internal or external package cracks may occur due to vaporization of the moisture in them (the so called popcorn effect). For details, refer to the Drypack information in the *Data Handbook IC26; Integrated Circuit Packages; Section: Packing Methods*.

[3] These transparent plastic packages are extremely sensitive to reflow soldering conditions and must on no account be processed through more than one soldering cycle or subjected to infrared reflow soldering with peak temperature exceeding 217 °C ± 10 °C measured in the atmosphere of the reflow oven. The package body peak temperature must be kept as low as possible.

- [4] These packages are not suitable for wave soldering. On versions with the heatsink on the bottom side, the solder cannot penetrate between the printed-circuit board and the heatsink. On versions with the heatsink on the top side, the solder might be deposited on the heatsink surface.
- [5] If wave soldering is considered, then the package must be placed at a 45° angle to the solder wave direction. The package footprint must incorporate solder thieves downstream and at the side corners.
- [6] Wave soldering is suitable for LQFP, QFP and TQFP packages with a pitch (e) larger than 0.8 mm; it is definitely not suitable for packages with a pitch (e) equal to or smaller than 0.65 mm.
- [7] Wave soldering is suitable for SSOP, TSSOP, VSO and VSSOP packages with a pitch (e) equal to or larger than 0.65 mm; it is definitely not suitable for packages with a pitch (e) equal to or smaller than 0.5 mm.
- [8] Image sensor packages in principle should not be soldered. They are mounted in sockets or delivered pre-mounted on flex foil. However, the image sensor package can be mounted by the client on a flex foil by using a hot bar soldering process. The appropriate soldering profile can be provided on request.
- [9] Hot bar soldering or manual soldering is suitable for PMFP packages.

15. Revision history

Table 9: Revision history

Document ID	Release date	Data sheet status	Change notice	Doc. number	Supersedes
TZA3050_3	20050407	Product data sheet	-	9397 750 14806	TZA3050_2
Modifications:	<ul style="list-style-type: none">The format of this data sheet has been redesigned to comply with the new presentation and information standard of Philips Semiconductors.				
TZA3050_2	20030326	Product specification	-	9397 750 11274	TZA3050_1
Modifications:	<ul style="list-style-type: none">Specification changed from Preliminary to Product.				
TZA3050_1	20021106	Preliminary specification	-	9397 750 10204	-

16. Data sheet status

Level	Data sheet status ^[1]	Product status ^[2] ^[3]	Definition
I	Objective data	Development	This data sheet contains data from the objective specification for product development. Philips Semiconductors reserves the right to change the specification in any manner without notice.
II	Preliminary data	Qualification	This data sheet contains data from the preliminary specification. Supplementary data will be published at a later date. Philips Semiconductors reserves the right to change the specification without notice, in order to improve the design and supply the best possible product.
III	Product data	Production	This data sheet contains data from the product specification. Philips Semiconductors reserves the right to make changes at any time in order to improve the design, manufacturing and supply. Relevant changes will be communicated via a Customer Product/Process Change Notification (CPCN).

[1] Please consult the most recently issued data sheet before initiating or completing a design.

[2] The product status of the device(s) described in this data sheet may have changed since this data sheet was published. The latest information is available on the Internet at URL <http://www.semiconductors.philips.com>.

[3] For data sheets describing multiple type numbers, the highest-level product status determines the data sheet status.

17. Definitions

Short-form specification — The data in a short-form specification is extracted from a full data sheet with the same type number and title. For detailed information see the relevant data sheet or data handbook.

Limiting values definition — Limiting values given are in accordance with the Absolute Maximum Rating System (IEC 60134). Stress above one or more of the limiting values may cause permanent damage to the device. These are stress ratings only and operation of the device at these or at any other conditions above those given in the Characteristics sections of the specification is not implied. Exposure to limiting values for extended periods may affect device reliability.

Application information — Applications that are described herein for any of these products are for illustrative purposes only. Philips Semiconductors make no representation or warranty that such applications will be suitable for the specified use without further testing or modification.

18. Disclaimers

Life support — These products are not designed for use in life support appliances, devices, or systems where malfunction of these products can reasonably be expected to result in personal injury. Philips Semiconductors customers using or selling these products for use in such applications do so at their own risk and agree to fully indemnify Philips Semiconductors for any damages resulting from such application.

Right to make changes — Philips Semiconductors reserves the right to make changes in the products - including circuits, standard cells, and/or software - described or contained herein in order to improve design and/or performance. When the product is in full production (status 'Production'), relevant changes will be communicated via a Customer Product/Process Change Notification (CPCN). Philips Semiconductors assumes no responsibility or liability for the use of any of these products, conveys no license or title under any patent, copyright, or mask work right to these products, and makes no representations or warranties that these products are free from patent, copyright, or mask work right infringement, unless otherwise specified.

19. Contact information

For additional information, please visit: <http://www.semiconductors.philips.com>

For sales office addresses, send an email to: sales.addresses@www.semiconductors.philips.com

20. Contents

1	General description	1	16	Data sheet status	23
2	Features	1	17	Definitions	23
2.1	General	1	18	Disclaimers	23
2.2	Control	2	19	Contact information	23
2.3	Protection	2			
3	Applications	2			
4	Ordering information	2			
5	Block diagram	3			
6	Pinning information	4			
6.1	Pinning	4			
6.2	Pin description	4			
7	Functional description	5			
7.1	Data and clock input	5			
7.2	Retiming	6			
7.3	Pulse width adjustment	6			
7.4	Modulator output stage	6			
7.5	Average loop control	6			
7.6	Direct current setting	6			
7.7	Soft start	6			
7.8	Burst mode	7			
7.9	Alarm functions	7			
7.10	Enable	7			
7.11	Reference block	7			
8	Limiting values	7			
9	Thermal characteristics	8			
10	Static characteristics	8			
11	Dynamic characteristics	11			
12	Application information	12			
12.1	Design equations	12			
12.1.1	Bias and modulation currents	12			
12.1.2	Average monitor current	13			
12.1.3	Alarm operating current	14			
12.1.4	Alarm monitor current	15			
12.1.5	Pulse width adjustment	15			
12.2	Burst mode application	15			
12.3	Average loop control	17			
13	Package outline	18			
14	Soldering	19			
14.1	Introduction to soldering surface mount packages	19			
14.2	Reflow soldering	19			
14.3	Wave soldering	19			
14.4	Manual soldering	20			
14.5	Package related soldering information	20			
15	Revision history	22			

© Koninklijke Philips Electronics N.V. 2005

All rights are reserved. Reproduction in whole or in part is prohibited without the prior written consent of the copyright owner. The information presented in this document does not form part of any quotation or contract, is believed to be accurate and reliable and may be changed without notice. No liability will be accepted by the publisher for any consequence of its use. Publication thereof does not convey nor imply any license under patent- or other industrial or intellectual property rights.

Date of release: 7 April 2005
Document number: 9397 750 14806

Published in The Netherlands

