

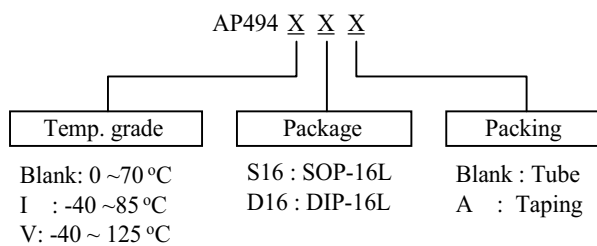
# AP494

## Voltage Mode PWM Controller

### ■ Features

- Complete PWM Power Control Circuitry
- Uncommitted Outputs for 200-mA Sink or Source Current
- Output Control Selects Single-Ended or Push-Pull Operation
- Internal Circuitry Prohibits Double Pulse at Either Output
- Variable Dead Time Provides Control Over Total Range
- Internal Regulator Provides a Stable 5-V Reference Supply with 3% Tolerance
- Circuit Architecture allows Easy Synchronization

### ■ Ordering Information



### ■ Description

The AP494 incorporates on a single monolithic chip all the functions required in the construction of a pulse-width-modulation control circuit. Designed primarily for power supply control, this device offers the systems engineer the flexibility to tailor the power supply control circuitry to a specific application.

The AP494 contains two error amplifiers, an on-chip adjustable oscillator, a dead-time control (DTC) comparator, a pulse-steering control flip-flop, a 5-V, 3%-precision regulator, and output-control circuits.

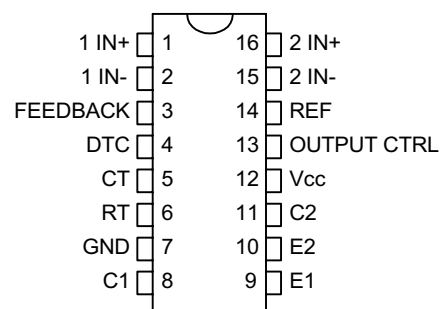
The error amplifiers exhibit a common-mode voltage range from  $-0.3V$  to  $V_{CC} - 2V$ . The dead-time control comparator has a fixed offset that provides approximately 5% dead time. The on-chip oscillator may be bypassed by terminating RT to the reference output and providing a sawtooth input to CT, or it may drive the common circuits in synchronous multiple-rail power supplies.

The uncommitted output transistors provide either common-emitter or emitter-follower output capability. The AP494 provides for push-pull or single-ended output operation, which may be selected through the output-control function. The architecture of this device prohibits the possibility of either output being pulsed twice during push-pull operation.

The AP494 is characterized for operation from 0°C to 70°C.

### ■ Connection Diagram

(TOP VIEW)

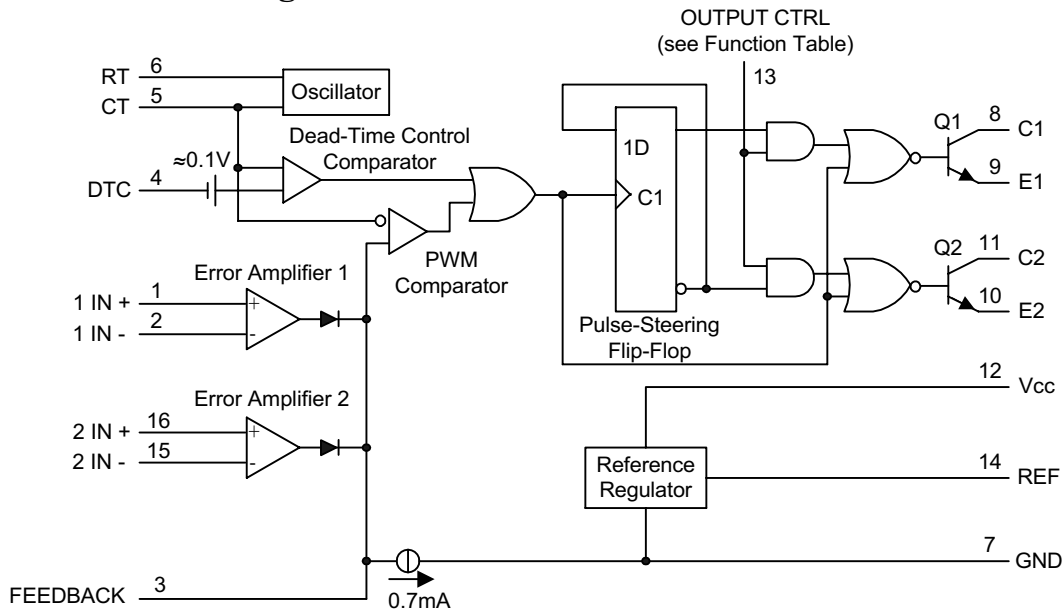


# AP494

## Voltage Mode PWM Controller



### Functional Block Diagram



### Absolute Maximum Ratings

Rating	Symbol	Value	Unit
Power Supply Voltage	$V_{CC}$	40	V
Collector Output Voltage	$V_{C1}, V_{C2}$	40	V
Collector Output Current (Each transistor)	$I_{C1}, I_{C2}$	500	mA
Amplifier Input Voltage Range	$V_{IR}$	-0.3 to +40	V
Power Dissipation @ $T_A \leq 45^\circ\text{C}$	$P_D$	1000	mW
Thermal Resistance, Junction-to-Ambient	$R_{\theta JA}$	80	$^\circ\text{C}/\text{W}$
Operating Junction Temperature	$T_J$	125	$^\circ\text{C}$
Storage Temperature Range	$T_{stg}$	-55 to +125	$^\circ\text{C}$
Operating Ambient Temperature Range	$T_A$	0 to +70	$^\circ\text{C}$
Derating Ambient Temperature	$T_A$	45	$^\circ\text{C}$

### Recommended Operating Conditions

Characteristics	Symbol	Min	Typ	Max	Unit
Power Supply Voltage	$V_{CC}$	7.0	15	40	V
Collector Output Voltage	$V_{C1}, V_{C2}$	-	30	40	V
Collector Output Current (Each transistor)	$I_{C1}, I_{C2}$	-	-	200	mA
Amplified Input Voltage	$V_{in}$	-0.3	-	$V_{CC}-2.0$	V
Current Into Feedback Terminal	$I_{fb}$	-	-	0.3	mA
Reference Output Current	$I_{ref}$	-	-	10	mA
Timing Resistor	$R_T$	1.8	30	500	$k\Omega$
Timing Capacitor	$C_T$	0.0047	0.001	10	$\mu\text{F}$
Oscillator Frequency	$f_{OSC}$	1.0	40	200	kHz

# AP494



## Voltage Mode PWM Controller

### ■ Electrical Characteristics

( $V_{CC}=15V$ ,  $C_T=0.01\mu F$ ,  $R_T=12\text{ k}\Omega$ , unless otherwise noted.) For typical values  $T_A=25^\circ C$ , for min/max values  $T_A$  is the operating ambient temperature range that applies, unless otherwise noted)

Characteristics	Symbol	Min	Typ	Max	Unit
-----------------	--------	-----	-----	-----	------

#### REFERENCE SECTION

Reference Voltage ( $I_O=1.0\text{mA}$ )	$I_{ref}$	4.85	5.0	5.15	V
Line Regulation ( $V_{CC}=7.0\text{ V to }40\text{V}$ )	$Reg_{line}$	-	2.0	25	mV
Load Regulation ( $I_O=1.0\text{mA to }20\text{mA}$ )	$Reg_{load}$	-	3.0	15	mA
Short Circuit Output Current ( $I_{ref}=0\text{ V}$ )	$I_{SC}$	4.5	60	75	mA

#### OUTPUT SECTION

Collector Off-State Current ( $V_{CC}=40V$ , $V_{CE}=40V$ )	$I_{C(off)}$	-	2.0	100	$\mu A$
Emitter Off-State Current ( $V_{CC}=40V$ , $V_C=40V$ , $V_E=0V$ )	$I_{E(off)}$	-	-	-100	$\mu A$
Collector-Emitter Saturation Voltage (Note 1) Common-Emitter ( $V_E=0V$ , $I_C=200\text{mA}$ )	$V_{sat(C)}$	-	1.1	1.5	V
Emitter-Follower ( $V_C=15V$ , $I_E=-200\text{mA}$ )	$V_{sat(E)}$	-	1.5	2.5	
Output Control Pin Current Low State ( $V_{OC}\leq 0.4V$ )	$I_{OCL}$	-	10	-	$\mu A$
High State ( $V_{OC}=V_{ref}$ )	$I_{OCH}$	-	0.2	3.5	mA
Output Voltage Rise Time Common-Emitter (See Figure 4) Emitter-Follower (See Figure 5)	$t_r$	-	100	200	ns
Output Voltage Fall Time Common-Emitter (See Figure 4) Emitter-Follower (See Figure 5)	$t_f$	-	25	100	ns

**NOTE:** 1. Low duty cycle pulse techniques are used during test to maintain junction temperature as close to ambient temperature as possible.

#### ERROR AMPLIFIER SECTION

Input Offset Voltage ( $V_{O(Pin\ 3)}=2.5V$ )	$V_{IO}$	-	2.0	10	mV
Input Offset Current ( $V_{O(Pin\ 3)}=2.5V$ )	$I_{IO}$	-	5.0	250	nA
Input Bias Current ( $V_{O(Pin\ 3)}=2.5V$ )	$V_{IB}$	-	-0.1	-0.1	$\mu A$
Input Common Mode Voltage Range ( $V_{CC}=40V$ , $T_A=25^\circ C$ )	$I_{ICR}$	-0.3 to $V_{CC}-2.0$			V
Open Loop Voltage Gain ( $\Delta V_O=3.0V$ , $V_O=0.5V\text{ to }3.5V$ , $R_L=2.0\text{ k}\Omega$ )	$A_{VOL}$	70	95	-	dB
Unity-Gain Crossover Frequency ( $V_O=0.5V\text{ to }3.5V$ , $R_L=2.0\text{ k}\Omega$ )	$f_c$	-	350	-	kHz
Common Mode Rejection Ratio ( $V_{CC}=40V$ )	CMRR	64	90	-	dB
Output Sink Current ( $V_{O(Pin\ 3)}=0.7V$ )	$I_{O-}$	0.3	0.7	-	mA
Output Source Current ( $V_{O(Pin\ 3)}=3.5V$ )	$I_{O+}$	-10	-15	-	mA

#### PWM COMPARATOR SECTION (Test Circuit Figure 1)

Input Threshold Voltage (Zero Duty Cycle)	$V_{TH}$	-	2.5	4.5	V
Input Sink Current ( $V_{(Pin\ 3)}=0.7V$ )	$I_L$	0.3	0.7	-	mA

#### DEADTIME CONTROL SECTION (Test Circuit Figure 1)

Input Bias Current (Pin 4) ( $V_{Pin4}=0V\text{ to }5.25V$ )	$I_{IB(DT)}$	-	-2.0	-10	$\mu A$
Maximum Duty Cycle, Each Output, Push-Pull Mode ( $V_{Pin4}=0V$ , $C_T=0.01\mu F$ , $R_T=12\text{ k}\Omega$ )	$DC_{max}$	45	48	50	%
Input Threshold Voltage (Pin4) (Zero Duty Cycle) (Maximum Duty Cycle)	$V_{th}$	-	2.8	3.3	V
		0	-	-	

# AP494

## Voltage Mode PWM Controller



### OSCILLATOR SECTION

Frequency ( $C_T=0.01\mu\text{F}, R_T=12\text{ k}\Omega$ )	$f_{\text{OSC}}$	-	10	-	kHz
Standard Deviation of Frequency* ( $C_T=0.001\mu\text{F}, R_T=30\text{ k}\Omega$ )	$\sigma f_{\text{OSC}}$	-	3.0	-	%
Frequency Change with Voltage ( $V_{\text{CC}}=7.0\text{V to }40\text{V}, T_A=25^\circ\text{C}$ )	$\Delta f_{\text{OSC}} (\Delta V)$	-	0.1	-	%
Frequency Change with Temperature ( $\Delta T_A=T_{\text{low}} \text{ to } T_{\text{high}}$ ) ( $C_T=0.01\mu\text{F}, R_T=12\text{ k}\Omega$ )	$\Delta f_{\text{OSC}} (\Delta T)$	-	-	12	%

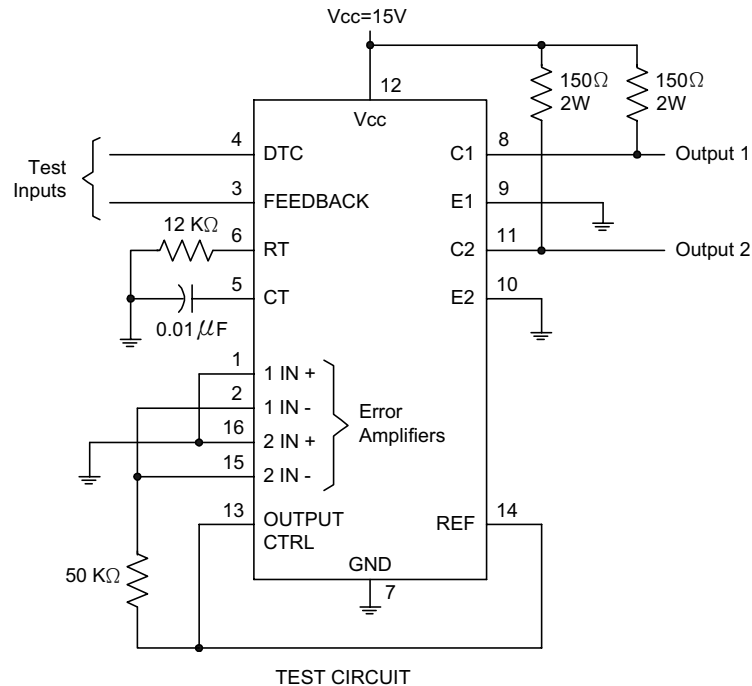
### TOTAL DEVICE

Standby Supply Current (Pin6 at $V_{\text{ref}}$ , All other inputs and outputs open) ( $V_{\text{CC}}=15\text{V}$ ) ( $V_{\text{CC}}=40\text{V}$ )	$I_{\text{CC}}$	-	5.5 7.0	10 15	mA
Average Supply Current ( $C_T=0.01\mu\text{F}, R_T=12\text{ k}\Omega, V_{(\text{pin}4)}=2.0\text{V}$ ) ( $V_{\text{CC}}=15\text{V}$ ) (See Figure 4)		-	7.0	-	mA

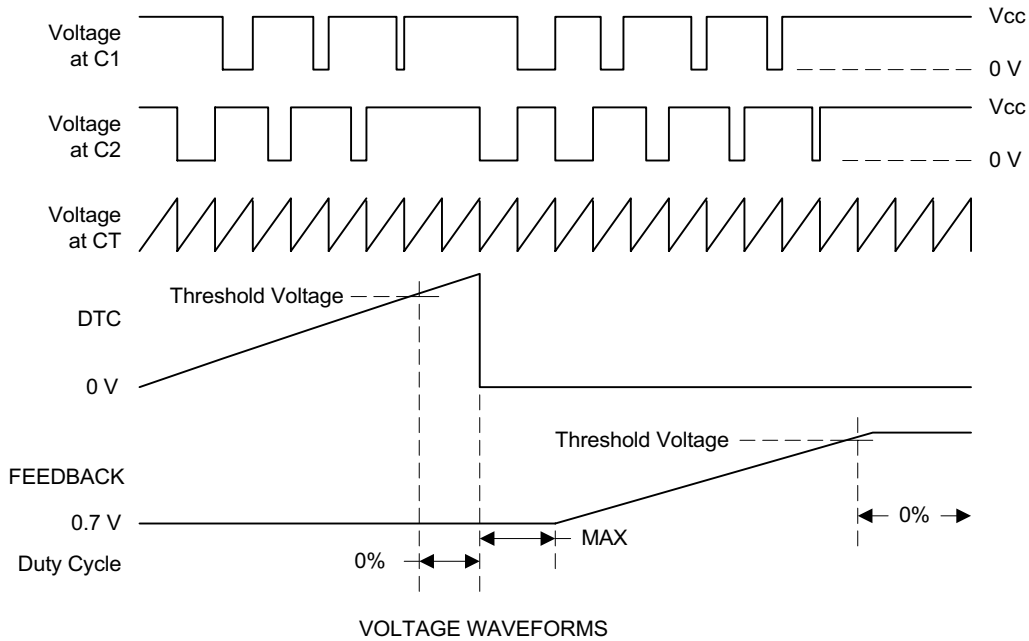
\*Standard deviation is a measure of the statistical distribution about the mean as derived from the formula,  $\sigma$

$$\sigma = \sqrt{\frac{\sum_{n=1}^N (X_n - \bar{X})^2}{N-1}}$$

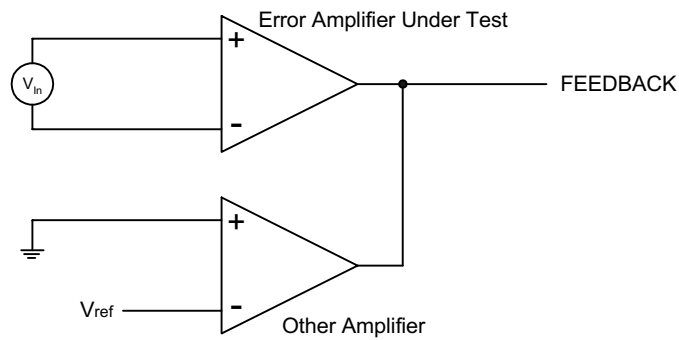
Figure 1. PARAMETER MEASUREMENT INFORMATION



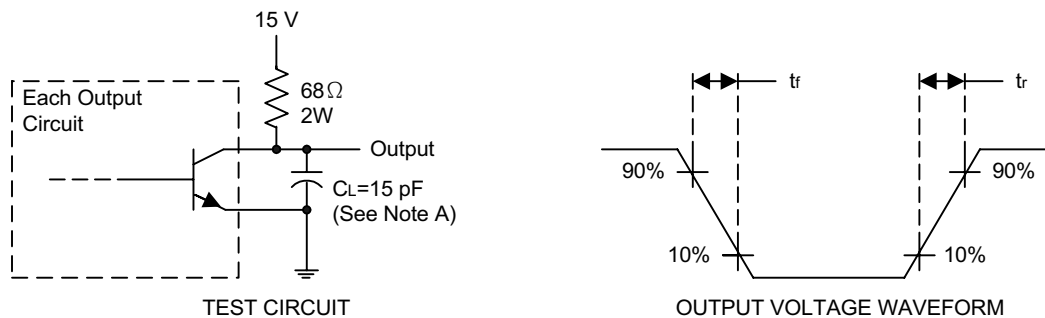
**Figure 2. OPERATIONAL TEST CIRCUIT AND WAVEFORMS**



**Figure 3. AMPLIFIER CHARACTERISTICS**

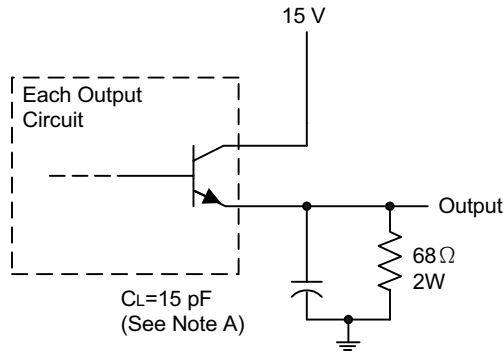


**Figure 4. COMMON-EMITTER CONFIGURATION**



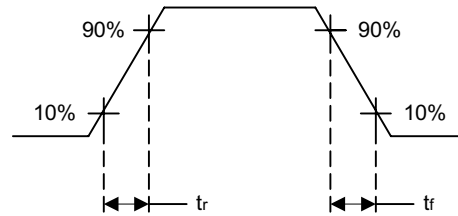
NOTE A. CL includes probe and jig capacitance.

**Figure 5. EMITTER-FOLLOWER CONFIGURATION**



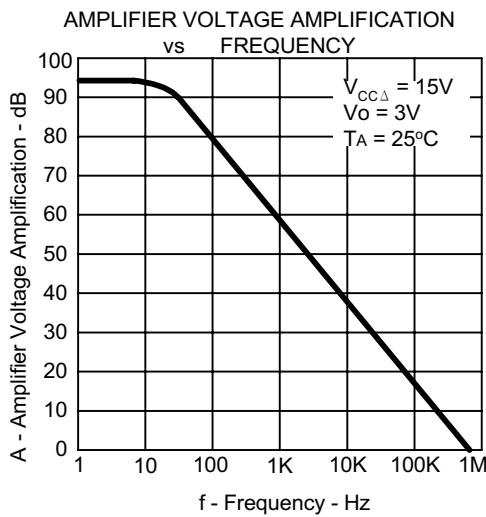
TEST CIRCUIT

NOTE A. CL includes probe and jig capacitance.

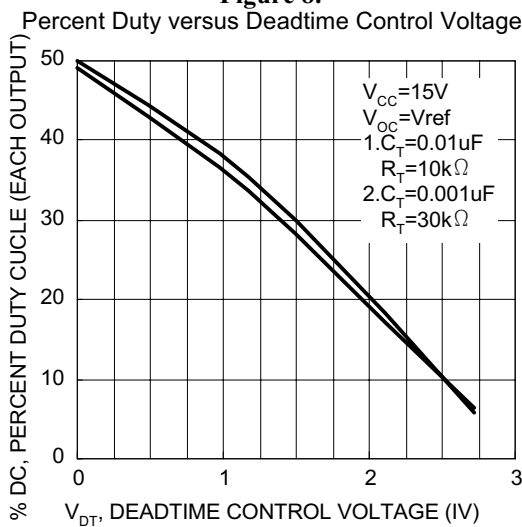


OUTPUT VOLTAGE WAVEFORM

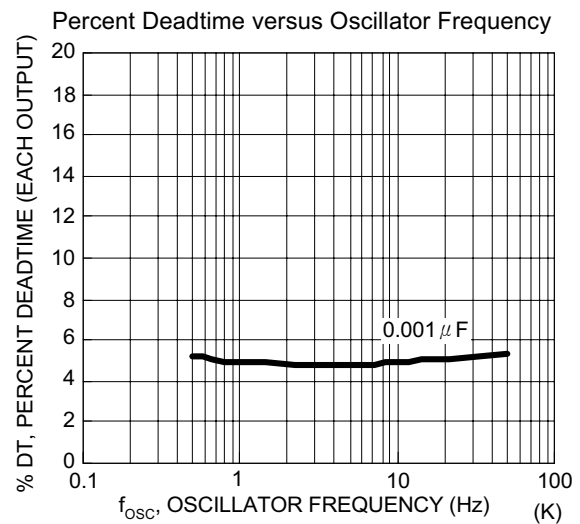
**Figure 6.**



**Figure 8.**



**Figure 7.**



**Figure 9.**

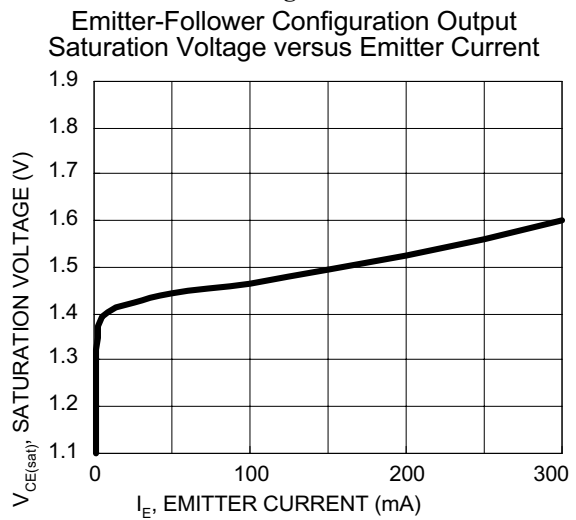


Figure 10.

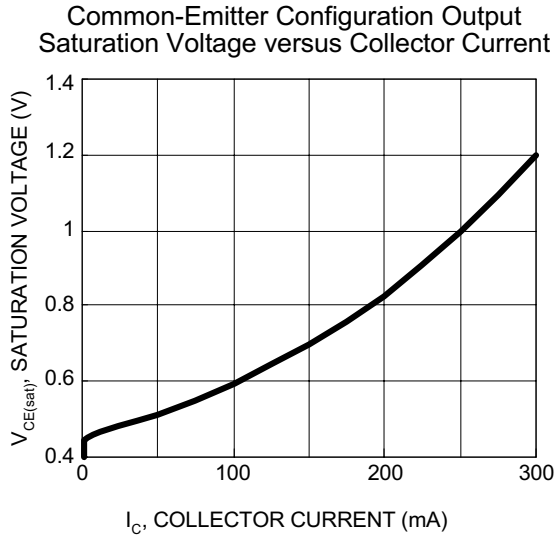


Figure 11.

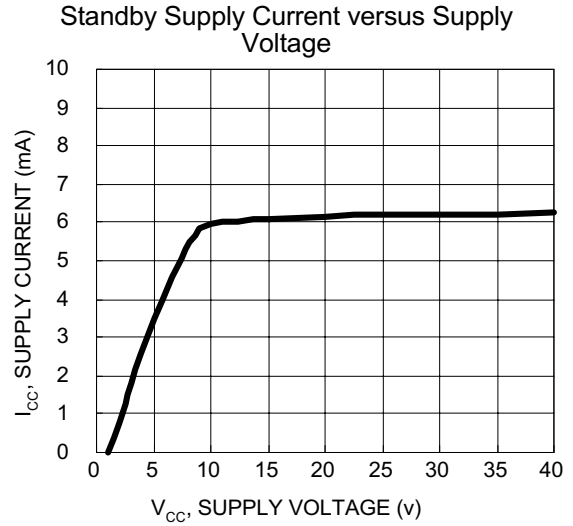
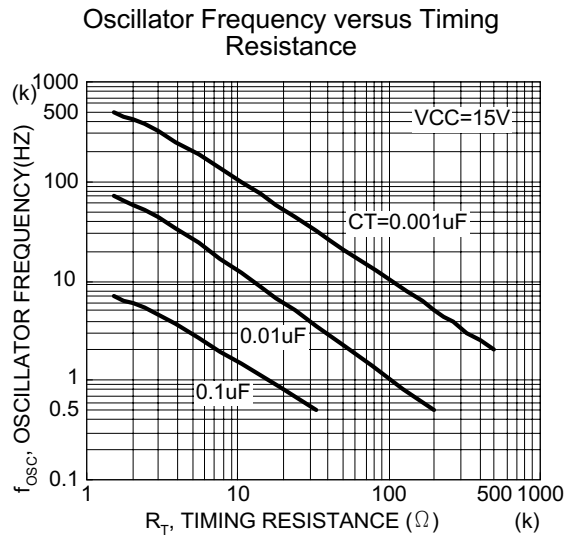


Figure 12.



# AP494

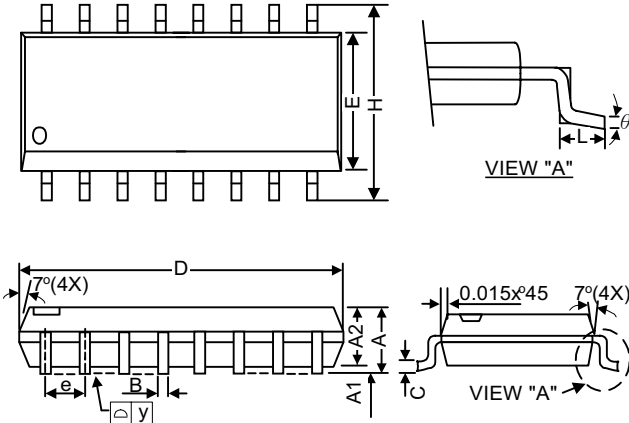
## Voltage Mode PWM Controller



### ■ Package Dimension

#### (1) SOP-16L

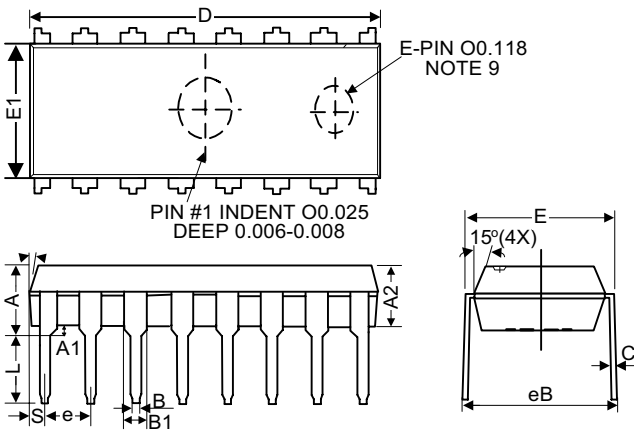
Package Dimension



Symbols	MILLIMETER			INCH		
	MIN	NOM	MAX	MIN	NOM	MAX
A	1.40	1.60	1.75	0.055	0.063	0.069
A1	0.10	-	0.25	0.040	-	0.010
A2	1.30	1.45	1.50	0.051	0.057	0.059
B	0.33	0.41	0.51	0.013	0.016	0.020
C	0.19	0.20	0.25	0.007 5	0.008	0.009 8
D	9.80	9.91	10.01	0.386	0.390	0.394
E	3.80	3.91	4.00	0.150	0.154	0.157
e	-	1.27	-	-	0.050	-
H	5.79	5.99	6.20	0.228	0.236	0.244
L	0.38	0.71	1.27	0.015	0.028	0.050
Θ	0	-	8	0	-	8

#### (2) PDIP-16L

Package Dimension



Symbol	MILLIMETER		
	MIN	NOM	MAX
A	*	*	5.33
A1	0.38	*	*
A2	3.1	3.3	3.5
B	0.36	0.46	0.56
B1	1.4	1.52	1.65
B2	0.81	0.99	1.14
C	0.2	0.25	0.36
D	18.9	19.10	19.30
E	7.62	7.94	8.26
E1	6.15	6.35	6.55
e	*	2.54	*
L	2.92	3.3	3.81
eB	8.38	8.89	9.4
S	0.71	0.84	0.97