

10-bit 33MSPS A/D Converter

Description

The CXA1844Q is a 10-bit 33MSPS 2-step parallel type A/D converter for video signal processing.

This A/D converter operates on $\pm 5V$ power supplies. The analog signal can be converted to the digital signal by using this IC in conjunction with the Sample-and-hold IC (CXA1843Q).

Features

- Maximum operating speed : 33MSPS (Min.)
- Resolution : 10-bit
- Low power dissipation : 320mW (Typ.)
- Wide-band analog input : 15MHz
- Low input capacitance : 50 pF (Typ.)
- Built-in digital correction
(Compensation within ± 16 LSB)
- TTL input (Except CLK which is ECL LIKE)
- TTL output
- Output code : binary/2S complement/
1S complement

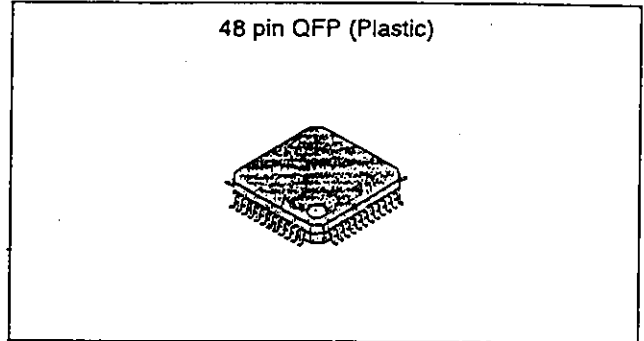

Function

10-bit 33MSPS 2-step parallel type A/D converter

Structure

Bipolar silicon monolithic IC

Applications

High resolution video signal processing

Block Diagram

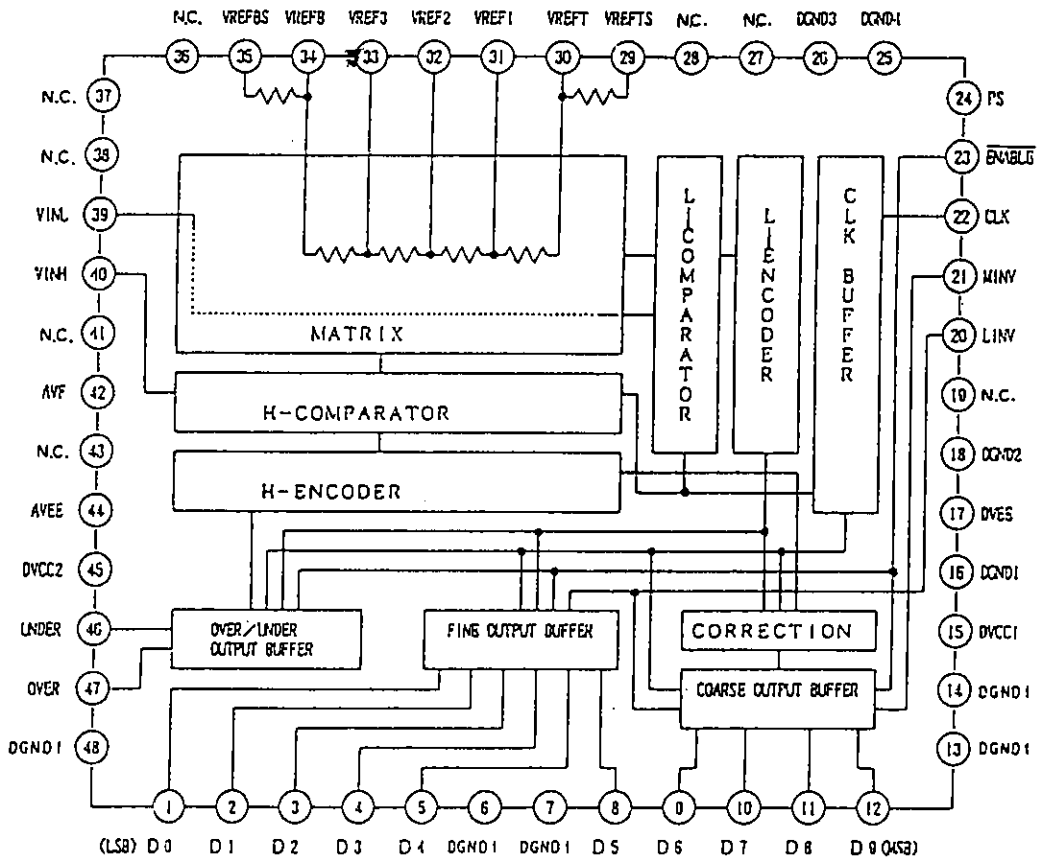

Sony reserves the right to change products and specifications without prior notice. This information does not convey any license by any implication or otherwise under any patents or other right. Application circuits shown, if any, are typical examples illustrating the operation of the devices. Sony cannot assume responsibility for any problems arising out of the use of these circuits.

Absolute Maximum Ratings (Ta=25°C)

• Supply voltage	DVcc1	0 to +6	V
	DVcc2	0 to +6	V
	AVEE	-6 to 0	V
	DVEE	-6 to 0	V
• Analog input voltage	VINH	AVEE to AVF+0.3	V
	VINL	AVEE to AVF+0.3	V
• Reference voltage	VREFT	AVEE to AVF+0.3	V
	VREFB	AVEE to AVF+0.3	V
• Digital input voltage	CLK	DGND1-0.5 to DVcc1	V
	MINV	DGND1-0.5 to DVcc1	V
	LINV	DGND1-0.5 to DVcc1	V
	PS	DGND1-0.5 to DVcc1	V
	ENABLE	DGND1-0.5 to DVcc1	V
• Digital output voltage	Vo	DGND1-0.5 to +3.6	V
	(Vo: The voltage is applied to the output pin for high impedance output.)		
• Storage temperature	Tstg	-65 to 150	°C
• Allowable power dissipation	Pd	0.62	W

Recommended Operating Conditions

		Min.	Typ.	Max.	Unit
• Supply voltage	DVcc1	+4.75	+5	+5.25	V
	DVcc2	+4.75	+5	+5.25	V
	DGND1		0		V
	DGND2		0		V
	DGND3		0		V
	DGND4		0		V
	AVF	+0.5	+0.7	+0.9	V
	AVEE	-5.25	-5	-4.75	V
• Analog input voltage	DVEE	-5.25	-5	-4.75	V
	VINH	-2		0	V
• Reference voltage	VINL	-2		0	V
	VREFT	-0.1	0	+0.1	V
• Digital input voltage	VREFB	-2.1	-2	-1.9	V
	(CLK)				
• Digital input voltage	VIH1	DVcc1-0.9	DVcc1-0.75		V
	VIL1		DVcc1-1.5	DVcc1-1.35	V
	(MINV, LINV, PS, ENABLE)				
	VIH2	+2			V
• Clock width	VIL2			+0.8	V
	tPWH	14			ns
• Operating temperature	tPWL	13			ns
	Topr	-20		+75	°C

Pin Description

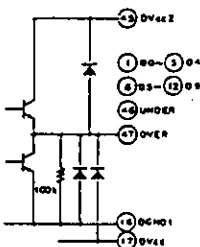
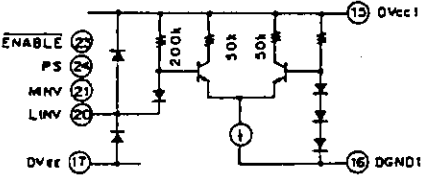
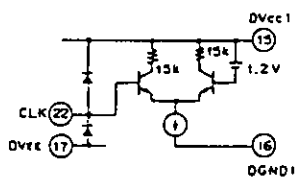
Pin No.	Symbol	I/O	Pin voltage	Equivalent circuit	Description
1 to 5 8 to 12	D0 to D9	O	TTL		Digital output D0 (LSB) to D9 (MSB)
46	UNDER	O			Underflow output
47	OVER	O			Overflow output
15	DVcc1	—	+5V Typ.		Digital power supply
45	DVcc2	—			
6, 7 13, 14 16, 48	DGND1	—	GND		Digital ground
18	DGND2				
26	DGND3				
25	DGND4				
17	DVEE	—	-5V Typ.		Digital negative power supply
44	AVEE	—			Analog negative power supply
20	LINV	I	TTL		This input can invert output form of D0 to D8. In open condition, this pin turns to high level input. (For details, refer to the Output Formula Chart.)
21	MINV	I	TTL		This input can invert output form of D9 (MSB). In open condition, this pin turns to high level input. (For details, refer to the Output Formula Chart.)
23	ENABLE	I	TTL		3-state control. Turns to enable when low is input. In open condition, this pin turns to high level input.
24	PS	I	TTL		Power save input. Power save condition is entered when high level is input. In open condition, this pin turns to high level input.
22	CLK	I	ECL LIKE		Clock input

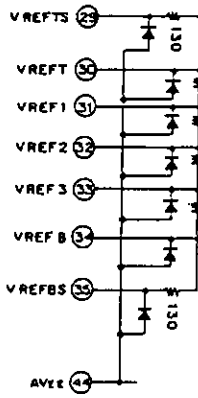
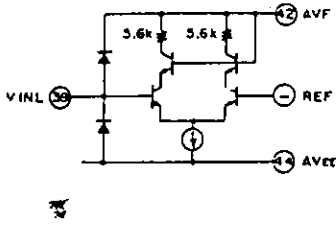
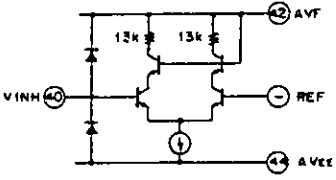
Pin No.	Symbol	I/O	Pin voltage	Equivalent circuit	Description
29	VREFTS	—	GND		Reference voltage sense (Top)
30	VREFT	I			Reference voltage force (Top)
31	VREF1	—	-0.5V		
32	VREF2	—	-1.0V		
33	VREF3	—	-1.5V		
34	VREFB	I	-2V		Reference voltage force (Bottom)
35	VREFBS	—			Reference voltage sense (Bottom)
39	VINL	I	-2V to 0V		Analog input (Lower comparator input)
40	VINH	I	-2V to 0V		Analog input (Upper comparator input)
42	AVF	—	+0.7V		Analog power supply
19, 27	N.C.	—	—		Open. Not connected to internal circuit, but connection to DGND (digital ground) is recommended.
28, 36 37, 38 41, 43	N.C.	—	—		Open. Not connected to internal circuit, but connection to AGND (analog ground) is recommended.

Electrical Characteristics

(Ta=25°C, DVcc1, 2=+5V, DGND1 to 4=0V, AVF=0.7V, AVEE, DVEE=-5V, VREFB=-2V, VREFT=0V)

Item	Symbol	Measurement Conditions	Min.	Typ.	Max.	Unit	
Resolution	n		10	10	10	bit	
DC characteristics							
Integral linearity error	EIL	VIN=-2 to 0V	-1.5		+1.5	LSB	
Differential linearity error	EDL		-1		+1	LSB	
Analog input							
Analog input current	IIN	VIN=0	0	25	120	μA	
Analog input capacitance	CIN	VIN=-1V+0.07Vrms		50		pF	
Analog input band width	BW	-1dB	15			MHz	
Reference voltage input							
Reference current	IREF	VREFB=-2V	-16	-10	-7	mA	
Reference resistance	RREF		120	200	280	Ω	
Offset voltage	EOT		5	10	25	mV	
	E08		5	10	25	mV	
Reference voltage	VREF1			-0.5		V	
	VREF2			-1.0		V	
	VREF3			-1.5		V	
Digital input							
Digital input voltage	VIH1	*1		DVcc1-0.9		V	
	VIL1				DVcc1-1.35	V	
	VIH2	*2		2		V	
	VIL2				0.8	V	
Digital input current	IiH1	*1	DVcc1 =Max.	VIH=DVcc1-0.8V	-10	+15	μA
	IiL1			VIL=DVcc1-1.6V	-15	+10	μA
	IiH2	*2		VIH=2.7V	-15	+15	μA
	IiL2			VIL=0.5V	-25	0	μA
Digital input characteristics				2		pF	

Item	Symbol	Measurement Conditions	Min.	Typ.	Max.	Unit	
Switching characteristics							
Maximum operating speed	Fc		33			MSPS	
Clock pulse width	tpWH	* 3	14			ns	
	tpWL		13			ns	
Sampling delay	tSH		-2	1	2	ns	
	tSL	-3	-2.5	1	ns		
Output delay time	tDLH	* 3 CL=30pF	4		18	ns	
	tDHL	* 5	4		18	ns	
3-state output disable time	tPHZ	* 4			150	ns	
	tPLZ				100	ns	
3-state output enable time	tpZH		* 6			300	ns
	tpZL				150	ns	
Digital output							
Digital output voltage	VOH	IOH=-500 μA	DVCC2=Min.	2.7	3.4		V
	VOL	IOL=1mA				0.5	V
Leak current during output off	IOZ	DVCC2=Max., VO=3.6V (Max.)	-20		150	μA	
Dynamic characteristics							
Differential gain error	DG	NTSC 40IRE mod ramp, Fc=14.3MSPS		0.5		%	
Differential phase error	DP			0.3		deg	
SNR	SNR	Fc=33MSPS FIN=1kHz		57		dB	
		Fc=33MSPS FIN=1MHz		53		dB	
		Fc=33MSPS FIN=8MHz		50		dB	

Item	Symbol	Measurement Conditions	Min.	Typ.	Max.	Unit
Power supply						
DVcc1 current	I _{DVCC1}	DVcc1=5V	9	20	30	mA
		*7 During power save	7.5	14.5	21.5	mA
DVcc2 current	I _{DVCC2}	DVcc2=5V	0.001	0.3	1	mA
		*7 During power save	0	0	0.1	mA
AVEE current + DVEE current	I _{VEE}	AVEE=-5V, DVEE=-5V	-57.5	-38	-20.8	mA
		*7 During power save	-4.4	-2.8	-1.6	mA
AVF current	I _{AVF}	AVF=0.7V	3.5	6.8	10.5	mA
		*7 During power save	30	55	85	μA
Power dissipation Pd=A+B+C A=(I _{DVCC1} +I _{DVCC2} + I _{VEE}) × 5V B=I _{AVF} × 0.7V C= I _{REF} × 2V	Pd		178	316	482	mW
		*7 During power save	59	107	163	mW

- *1 CLK input
- *2 MINV, LINV, ENABLE, and PS inputs
- *3 Refer to Timing Diagram (1)
- *4 Refer to Timing Diagram (2)
- *5 The load is a bi-state totem-pole output delay time test load circuit.
- *6 The load is a 3-state output test load circuit.
- *7 When PS and ENABLE inputs are in high level.

Bi-state Totem-pole Output Delay Time Test Load Circuit

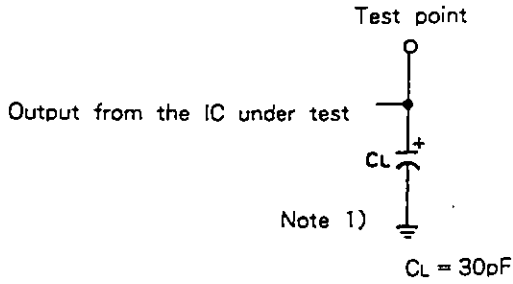

3-state Output Test Load Circuit

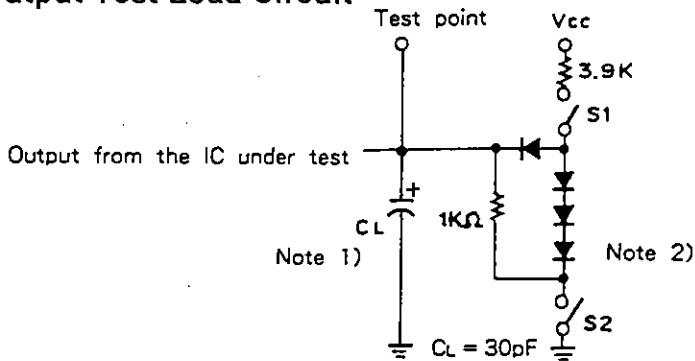

Test condition	S1	S2
tpZL	Close	Open
tpZH	Open	Close
tPLZ	Close	Close
tPHZ	Close	Close

Note 1) CL includes probe capacitance and parasitic capacitance in Test Board.

Note 2) All diodes are IS2076.

Error Rate Test Circuit

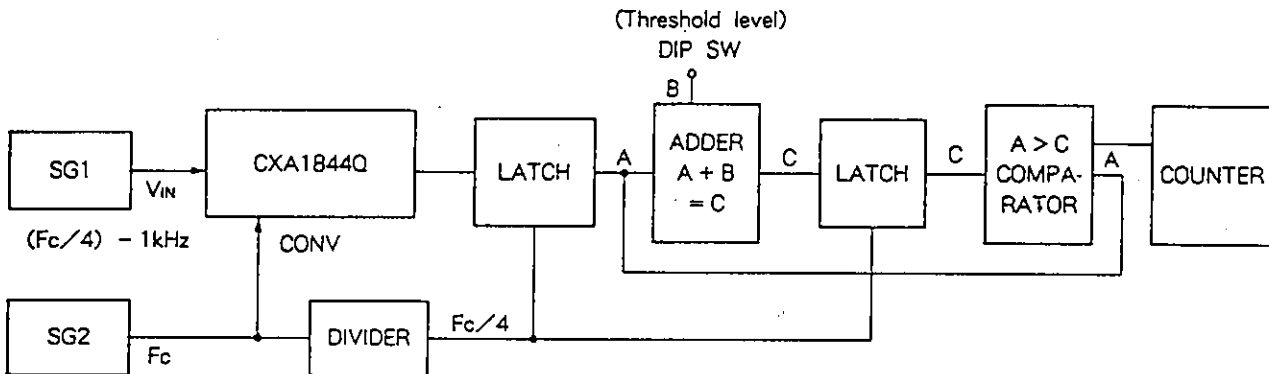

Notes on Operation

1. Analog ground (Analog ground on PCB)
Keep analog ground surface on PCB as wide as possible with impedance and resistance as low as possible.
2. Digital ground (DGND1, DGND2, DGND3, DGND4)
Upon mounting to PCB keep ground surface as wide as possible with impedance and resistance as low as possible.
Moreover, a common analog and digital ground immediately near ADC will help obtain characteristics smoothly.
3. Digital positive power supply (DVcc1, DVcc2)
Connect to the digital ground with a ceramic capacitor over $0.1\ \mu\text{F}$ and as close to the pins as possible.
Insert a ceramic capacitor between DVcc2 and DGND1 of TTL output power supply as shortly as possible because noise tends to occur.
4. Analog positive power supply (AVF)
As shown in the Standard Circuit, make the positive power supply about $+0.7\text{V}$ by connecting to the analog ground with a diode and $+5\text{V}$ with a pull-up resistor respectively.
Connect to the analog ground on PCB with a ceramic capacitor over $0.1\ \mu\text{F}$ as close to the pin as possible.
5. Analog negative power supply (AV \bar{E})
Connect to the analog ground on PCB with a ceramic capacitor over $0.1\ \mu\text{F}$ as close to the pin as possible.
6. Digital negative power supply (DV \bar{E})
Connect to the digital ground with a ceramic capacitor over $0.1\ \mu\text{F}$ as close to the pin as possible.
When $V_{\bar{E}}$ is divided into digital and analog, there is continuity because of about $4\ \Omega$ resistance between the two inside the IC. Accordingly, if an excessive potential difference (more than 100mV) is applied continuously, this may destroy the IC. To prevent the IC destruction, connect AV \bar{E} and DV \bar{E} with a inductance having good high frequency characteristics. Prevent noise mixing and the generation of potential difference between analog and digital.
7. Reference voltage (VREFTS, VREFT, VREF1, VREF2, VREF3, VREFB, VREFBS)
These pins provide reference voltage to upper and lower comparators. Voltage between VREFT and VREFB corresponds to input dynamic range.
There is a $200\ \Omega$ resistance between VREFT and VREFB. By applying 2V to both pins a current of about $10\ \text{mA}$ flows. When the reference voltage is destabilized by the clock, ADC characteristics are adversely affected. Connect VREFT and VREFB to the analog ground on PCB by means of a tantalum capacitor over $10\ \mu\text{F}$ and a ceramic capacitor over $0.1\ \mu\text{F}$ respectively. Also, connect each of VREF1, VREF2 and VREF3 to the analog ground on PCB using a ceramic capacitor over $0.1\ \mu\text{F}$. This will provide stability to the characteristics of high frequency. Strictly speaking on reference voltage VREFT side and VREFB side there is a respective about 10mV offset.
When there is no problem with the usage of those offset voltages, voltage is applied directly to VREFT, VREFB. In case the reference voltage is to be strictly applied, adjust to obtain an offset voltage of 0V , keeping VREFTS and VREFBS as sense pins and VREFT and VREFB as force pins to form a feedback loop circuit. For details, see the Standard Circuit.

8. Analog input (VINH, VINL)

VINH is the input pin for the upper comparator while VINL is the input pin for the lower comparator. Keep the input signal level within the level between VREFT and VREFB.

As this IC's analog input capacitance stands at about 50pF, it is necessary to drive with a buffer amplifier having sufficient driving capability. Also, when driving is done with the buffer amplifier of a low output impedance, as A/D converter input capacitance is large, ringing is generated and settling time grows longer. Here a small resistance of about 5 to 30Ω is connected in series between the buffer amplifier and each of A/D converter's VINH and VINL, as a dumping resistance. This eliminates ringing and shortens settling time. Also keep wiring between buffer amplifier and A/D converter as short as possible.

9. Clock input (CLK)

ECL LIKE input. Adds the signal of Vcc1 (5V) -0.8V at high level and Vcc1 (5V) -1.6V at low level. Clock line wiring should be the shortest possible while distanced from other signal lines to avoid affecting them.

This IC is 2-step parallel type A/D converter. Accordingly an external sample-and-hold circuit (SH) is necessary. However the timing between this SH circuit output waveform (A/D converter analog input waveform) and the A/D converter clock timing requires attention. In the relation between A/D converter clock and the A/D converter analog input signal, with the timing T_H of the rising edge of A/D converter clock, the upper comparator compares the input signal and the reference voltage to latch the results. After that, with the timing T_L of the falling edge of A/D converter clock, the lower comparator compares the input signal and reference signal to latch the results. (Strictly speaking, the sampling delay t_{SH} is in T_H and the sampling delay t_{SL} is in T_L .)

In this A/D converter, the lower comparator features a length of $\pm 32\text{mV}$ (± 16 LSB) redundancy in relation to the upper comparator. At the timing when the lower comparator compares input signal and reference signal to latch at the timing T_L , it is necessary to have the SH output settling performed. But at the timing when the upper comparator compares input signal and reference voltage to latch at the timing T_H , as long as the SH output is within the $\pm 32\text{mV}$ range to the final settling value, digital correction applies, A/D conversion precisely occurs. As seen from the above, A/D converter clock rise and fall timing versus SH output waveform should be duly considered. For the clock high level time t_{pWH} and low level time t_{pWL} , set to a value in excess of the time indicated for the respective operating conditions.

Output data is synchronously with the clock rising edge.

For details on timing, refer to the Timing Chart.

10. MINV input (MINV)

Digital output polarity inversion control pin of D9 (MSB).

TTL input. At open, turns to high level input.

For correspondence with analog input voltage and output data code, refer to the Output Formula Chart.

11. LINV input (LINV)

Digital output polarity inversion control pin of D8 to D0 (LSB).

TTL input. At open, turns to high level input.

For correspondence with analog input voltage and output data code, refer to the Output Formula Chart.

12. Output enable ($\overline{\text{ENABLE}}$)

3-state control pin of digital output (D0 to D9, UNDER, OVER)

TTL input. At open, turns to high level input. At that time digital output turns all to high impedance.

13. Power save input (PS)

Power save control pin of internal circuit.

TTL input. At open, turns to high level input.

To set to power save mode, turn both PS and $\overline{\text{ENABLE}}$ to high level input.

14. Digital output (D0 to D9)

Output pin of D9 (MSB) to D0 (LSB).

TTL output.

Output data polarity inversion is executed by means of MINV and LINV signals. Can output in binary, 1S complement and 2S complement.

Also, by turning $\overline{\text{ENABLE}}$ signal to high level, the output can be turned into high impedance output.

However, when the output level is for high impedance output or is in power save mode, the voltage of 3.6V or more must not be applied to prevent the destruction of IC.

For correspondence with analog input voltage and output data code, refer to the Output Formula Chart. For the timing, refer to the Timing Chart.

15. Overflow output (OVER)

When the input signal exceeds VREFT, overflow signal is output.

MINV and LINV have no effect on this pin.

Also by turning $\overline{\text{ENABLE}}$ signal to high level, the output can be turned into high impedance output.

However, when the output level is for high impedance output or is in power save mode, the voltage of 3.6V or more must not be applied to prevent the destruction of IC.

For correspondence with analog input voltage and output data code, refer to the Output Formula Chart.

For the timing, refer to the Timing Chart.

16. Underflow output (UNDER)

When the input signal turns below VREFB, underflow signal is output.

MINV and LINV have no effect on this pin.

Also by turning $\overline{\text{ENABLE}}$ signal to high level, the output can be turned into high impedance output.

However, when the output level is for high impedance output or is in power save mode, the voltage of 3.6V or more must not be applied to prevent the destruction of IC.

For correspondence with analog input voltage and output data code, refer to the Output Formula Chart.

For the timing, refer to the Timing Chart.

Output Formula Chart

ENABLE	0	0	0	0	1 (OPEN)	1 (OPEN)	1 (OPEN)	1 (OPEN)
MINV		1 (OPEN)						
LINV		1 (OPEN)						
OUTPUT		0F9876543210UF (MSB) (LSB)	0F9876543210UF (MSB) (LSB)	0F9876543210UF (MSB) (LSB)	0F9876543210UF (MSB) (LSB)	0F9876543210UF (MSB) (LSB)	0F9876543210UF (MSB) (LSB)	0F9876543210UF (MSB) (LSB)
0V	0	100000000000	101111111110	110000000000	111111111110	111111111110	111111111110	Z
:	1	000000000010	001111111100	010000000010	001111111100	010000000010	011111111100	Z
:	2	000000000100	001111111010	010000000100	001111111010	010000000100	011111111010	Z
:	3	000000000110	001111111000	010000000110	001111111000	010000000110	011111111000	Z
:	:	:	:	:	:	:	:	:
:	512	010000000000	011111111110	000000000000	011111111110	000000000000	001111111110	Z
:	:	:	:	:	:	:	:	:
:	1019	011111110110	010000001000	001111110110	010000001000	000000001000	000000001000	Z
:	1020	011111111000	010000000110	001111111000	010000000110	000000000110	000000000110	Z
:	1021	011111111010	010000000100	001111111010	010000000100	000000000100	000000000100	Z
:	1022	011111111100	010000000010	001111111100	010000000010	000000000010	000000000010	Z
-2V	1023	011111111111	010000000001	001111111111	010000000001	000000000001	000000000001	Z

0: VOLTAGE LEVEL-LOW OF: OVER FLOW
 1: VOLTAGE LEVEL-HIGH UF: UNDER FLOW
 Z: HIGH IMPEDANCE

Timing Chart (1)

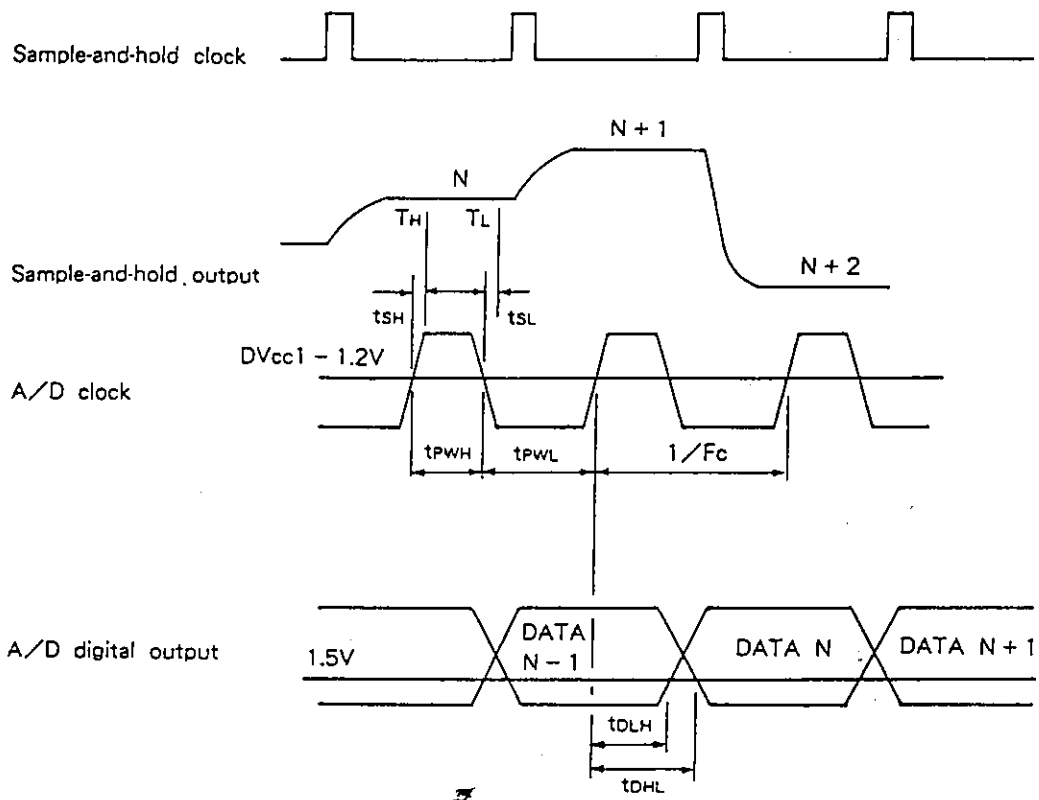

TH is the timing of latching result for the comparator of VIN and VREF in the upper comparators.
 TL is the timing of latching result for the comparator of VIN and VREF in the lower comparators.

Timing Chart (2)

Output waveform of 3-state enable and disable time *.
 (* Enable time= t_{PZL}/t_{PZH} , disable time= t_{PLZ}/t_{PHZ})

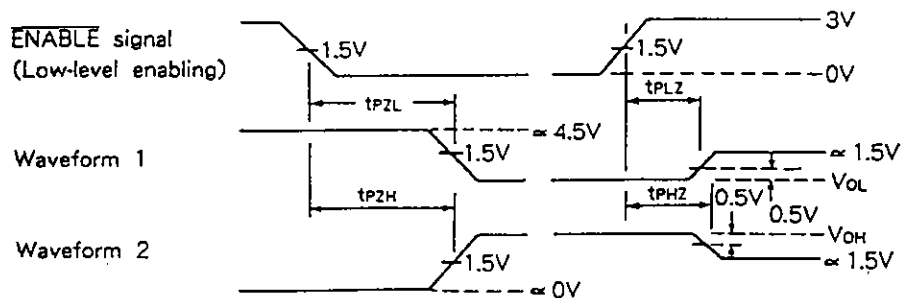

Notes) Waveform 1 indicates the output waveform when internal conditions are set to obtain a low level output, with the exception of when output is disabled by means of the $\overline{\text{ENABLE}}$ signal.
 Waveform 2 indicates the output waveform when internal conditions are set to obtain a high level output, with the exception of when output is disabled by means of the $\overline{\text{ENABLE}}$ signal.

Standard Circuit

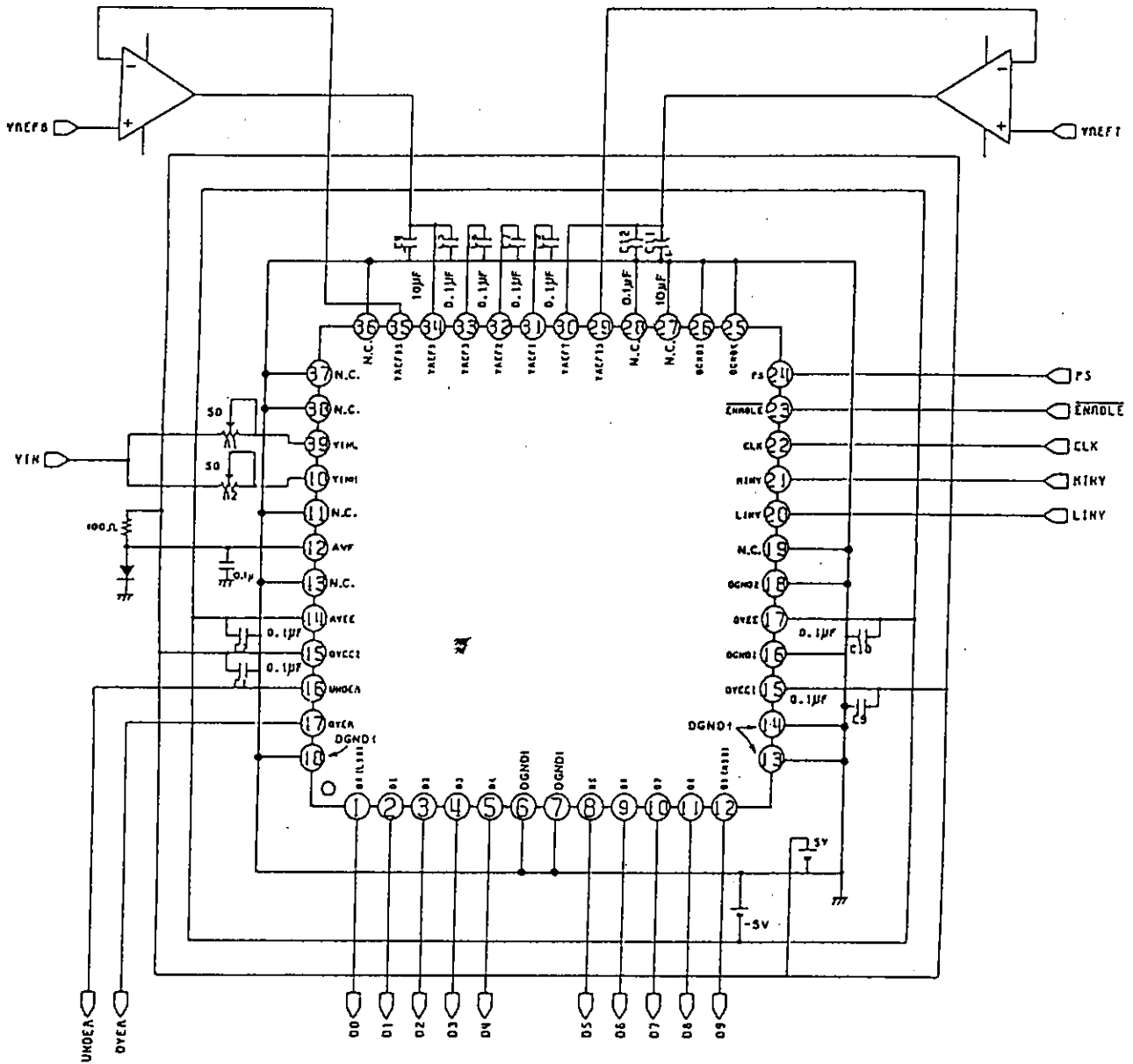

Package Outline Unit: mm

48PIN QFP (PLASTIC)

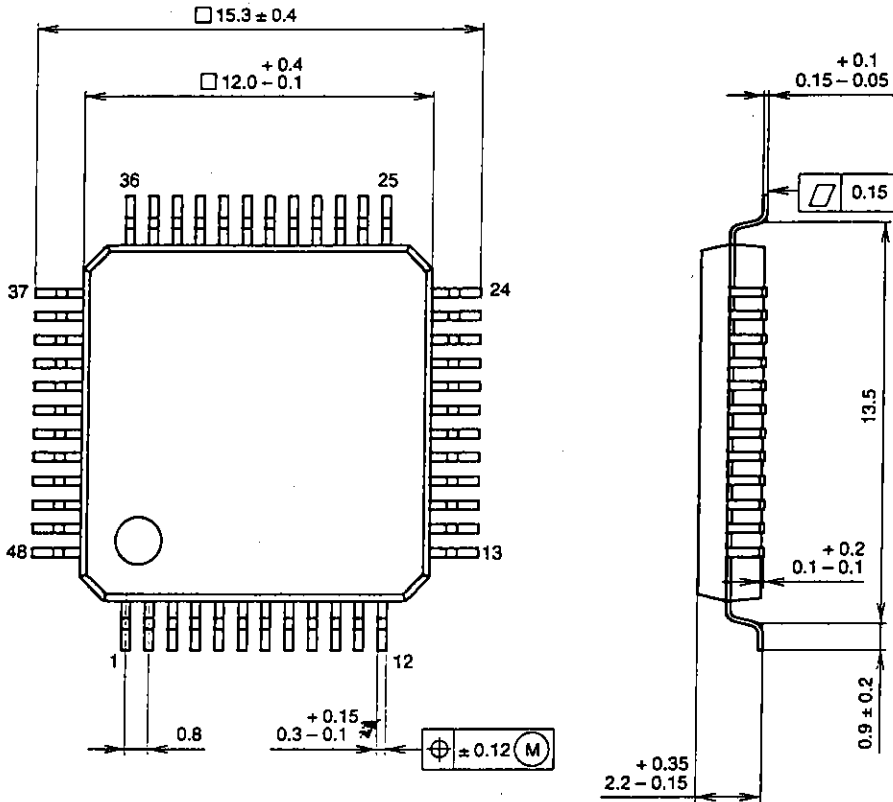

PACKAGE STRUCTURE

SONY CODE	QFP-48P-L04
EIAJ CODE	-QFP048-P-1212-B
JEDEC CODE	_____

PACKAGE MATERIAL	EPOXY RESIN
LEAD TREATMENT	SOLDER / PALLADIUM PLATING
LEAD MATERIAL	COPPER / 42 ALLOY
PACKAGE WEIGHT	0.7g

NOTE : PALLADIUM PLATING

This product uses S-PdPPF (Sony Spec.-Palladium Pre-Plated Lead Frame).