



The Infinite Bandwidth Company™

MIC809-5

Microprocessor Reset Circuits

General Description

The MIC809-5 is a power supply supervisor that provides under-voltage monitoring and power-on reset generation in an industry standard 3-pin SOT package and pinout. The reset output is asserted at power-on and any time the input voltage drops below the programmed threshold. It remains asserted for 30ms (min.) after the input subsequently rises back above the threshold boundary. The MIC809-5 has an active-low reset output. Hysteresis is included to prevent chattering due to noise, and the MIC809-5 is inherently immune to brief power supply transients. Typical supply current is a low 6µA. For those applications that require a manual reset function, see the MIC811/812. For those applications that require a longer reset timeout, see the MIC809/810. (The MIC809-5 is identical to the industry-standard MIC809 with the exception of a shorter reset timeout.)

Features

- Under-voltage monitor
- Power-on reset generation (30ms minimum)
- Choice of threshold voltages (contact Micrel regarding availability)
- Active-low reset output
- No external components required
- Rejects brief input transients
- Industry standard package and pinout
- 3-pin Itty-Bitty™ SOT23-3 package

Applications

- Monitoring processor, ASIC, or FPGA core and I/O voltages
- PDAs, hand-held PCs
- Embedded controllers
- Telecommunications systems
- Power supplies
- Wireless / Cellular systems
- Networking hardware

Ordering Information

Part Number	Marking**	Typical Application Voltage*	Nominal Threshold Voltage	T _{RST} (ms)	Junction Temperature Range	Package
MIC809-5S-U	IXxx	3.3V±5%	2.93	30	-40°C to +85°C	SOT23-3

*Other voltages available. Contact Micrel for details. Minimum order may apply. **xx indicates the lot code.

Typical Application

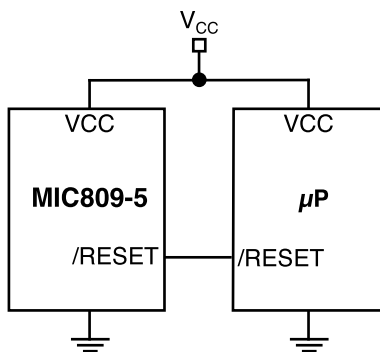

Typical Operating Circuit

Itty-Bitty is a trademark of Micrel, Inc.

Pin Configuration

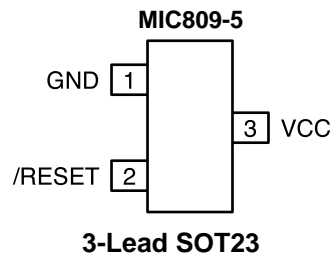

Pin Description

Pin Number	Pin Name	Pin Function
1	GND	Ground return for all IC functions.
2	/RESET	Digital Output. Active-low. Asserted whenever V_{CC} falls below the threshold voltage. It will remain asserted for no less than 30ms and be de-asserted after V_{CC} returns above the threshold.
3	VCC	Analog Input. Power supply input to the IC.

Absolute Maximum Ratings (Note 1)

Terminal Voltage (V_{CC})	-0.3V to 6.0V
Lead Temperature (soldering, 10 sec.)	300°C
Storage Temperature (T_S)	-65°C to 150°C
Rate of Rise (V_{CC})	100V/ μ s
ESD Rating, Note 3	

Operating Ratings (Note 2)

Ambient Temperature (T_A)	-40°C to +85°C
Power Dissipation ($T_A = +70^\circ\text{C}$)	320mW

Electrical Characteristics

$T_A = 25^\circ\text{C}$; $V_{CC} = 3.3\text{V}$ for MIC809-5S unless otherwise noted. Values in **bold** are for -40°C to $+85^\circ\text{C}$; unless otherwise noted

Symbol	Parameter	Condition	Min	Typ	Max	Units
V_{CC}	Operating Voltage Range	$T_A = 0^\circ\text{C}$ to 70°C	1.4		5.5	V
		$T_A = -40^\circ\text{C}$ to 85°C	1.6		5.5	V
I_{CC}	Supply Current	$V_{CC} < 3.6\text{V}$		6	10	μA
V_{TH}	Reset Voltage Threshold	S Voltage Options	2.85	2.93	3.00	V
V_{HYST}	Typical hysteresis			5		mV
T_{RST}	Reset Timeout Period		30		66	ms
T_{PROP}	Propogation delay	/RESET $< V_{OL}$, 100mV Overdrive		9.3		μs
V_{OH}	/RESET Output Voltage High	$I_{SOURCE} = 500\mu\text{A}$	$0.8 \cdot V_{CC}$			V
V_{OL}	/RESET Output Voltage Low	$V_{CC} = V_{TH}$ min., $I_{SINK} = 1.2\text{mA}$			0.3	V
		$V_{CC} > 1.4\text{V}$, $I_{SINK} = 50\mu\text{A}$, $T_A = 0^\circ\text{C}$ to $+70^\circ\text{C}$			0.3	V
		$V_{CC} > 1.6\text{V}$, $I_{SINK} = 50\mu\text{A}$, $T_A = -40^\circ$ to $+85^\circ\text{C}$			0.3	V

Note 1. Exceeding the absolute maximum rating may damage the device.

Note 2. The device is not guaranteed to function outside its operating rating.

Note 3. Devices are ESD sensitive. Handling precautions recommended. Human body model, 1.5k in series with 100pF.

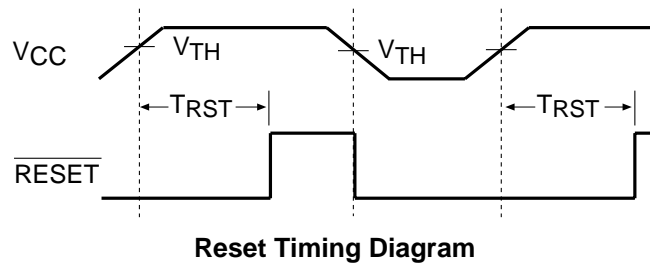
Timing Diagrams

Functional Diagram

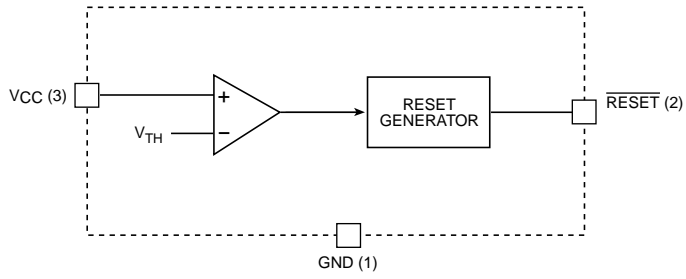

MIC809-5 Block Diagram

Applications Information

Microprocessor Reset

The /RESET pin is asserted whenever V_{CC} falls below the reset threshold voltage. The /RESET pin remains asserted for a period of 30ms after V_{CC} has risen above the reset threshold voltage. The reset function ensures the microprocessor is properly reset and powers up in a known condition after a power failure. /RESET will remain valid with V_{CC} as low as 1.4V.

Transients on V_{CC}

The MIC809-5 is inherently immune to very short “glitches” on V_{CC} . In the case of very brief transients, V_{CC} may drop below the under-voltage threshold without triggering a reset. As shown in the graph of Figure 1, the narrower the transient, the deeper the threshold overdrive that will be ignored. The line on the graph represents the typical allowable transient duration for a given amount of threshold overdrive that will *not* generate a reset. The data from which Figure 1 is derived was taken by adding negative-going square-wave pulses to a DC input voltage set at 0.5V above the actual measured threshold for the part being characterized.

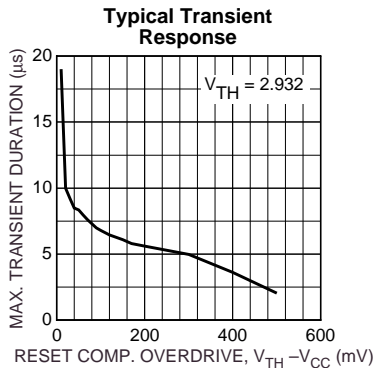

Figure 1. Comparator Overdrive vs. Duration

Ensuring Proper Operation at Low V_{CC}

At levels of V_{CC} below 1.4V, the MIC809-5’s output driver cannot always turn on sufficiently to produce a valid logic-low. In this situation, other circuits driven by /RESET could be allowed to float, causing undesired operation. (In most cases, however, it is expected that the circuits driven by the MIC809-5 will be similarly inoperative at $V_{CC} = 1.4V$.)

If a given application requires that /RESET be valid below $V_{CC} = 1.4V$, this can be accomplished by adding a pull-down resistor to the output. A value of 100kΩ is recommended, as this is usually an acceptable compromise of leakage current and pull-down current. The resistor’s value is not critical, however. See Figure 2.

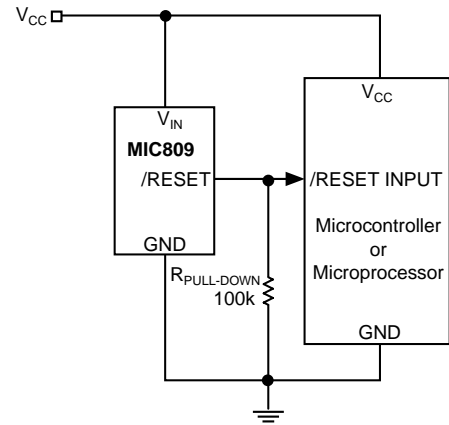

Figure 2. Ensuring a Valid /RESET Signal at Low Voltage

Interfacing to Processors with Bidirectional Reset Pins

Some microprocessors have reset signal pins that are bidirectional, rather than input only. The Motorola 68HC11 family is one example. To prevent excessive current flow when the processor asserts its reset output, a series resistor is employed between the MIC809-5’s output and the reset pin. This limits the current that will flow between the MIC809-5 and the reset pin to a theoretical maximum of V_{CC}/R_{SERIES} . Because this resistor also limits the drive capability of the supervisor’s output, a buffer may be required to drive additional circuitry. See Figure 3.

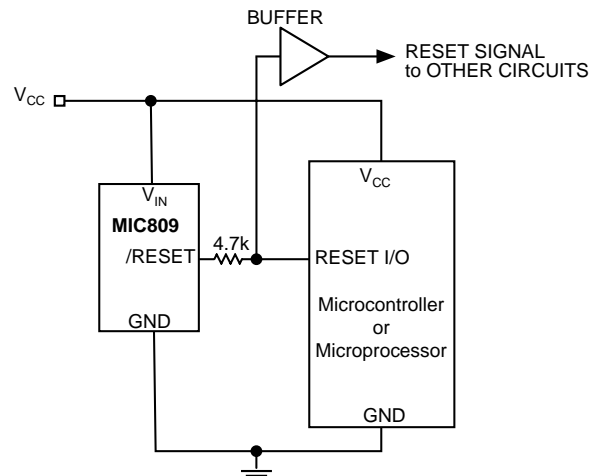
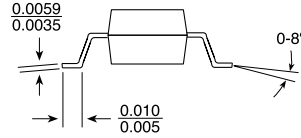
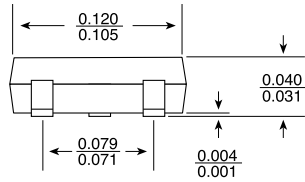
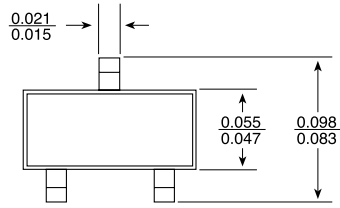

Figure 3. Interfacing to Processors with Bidirectional Reset Pins

Package Information



3-lead SOT-23 (M3)

MICREL INC. 1849 FORTUNE DRIVE SAN JOSE, CA 95131 USA

TEL + 1 (408) 944-0800 FAX + 1 (408) 944-0970 WEB <http://www.micrel.com>

This information is believed to be accurate and reliable, however no responsibility is assumed by Micrel for its use nor for any infringement of patents or other rights of third parties resulting from its use. No license is granted by implication or otherwise under any patent or patent right of Micrel Inc.

© 2001 Micrel Incorporated