



24LC08B/16B MODULES

8K/16K I²C™ Serial EEPROMs in ISO Micromodules

FEATURES

- ISO 7816 compliant contact locations
- Single supply with operation from 2.5-5.5V
- Low power CMOS technology
 - 1 mA active current typical
 - 10 μ A standby current typical at 5.5V
- Organized as 4 or 8 blocks of 256 bytes (4 x 256 x 8) or (8 x 256 x 8)
- 2-wire serial interface bus, I²C™ compatible
- Schmitt trigger inputs for noise suppression
- Output slope control to eliminate ground bounce
- 100 kHz (2.5V) and 400kHz (5V) compatibility
- Self-timed write cycle (including auto-erase)
- Page-write buffer for up to 16 bytes
- 2 ms typical write cycle time for page-write
- ESD protection > 4,000V
- 1,000,000 ERASE/WRITE cycles guaranteed
- Data retention > 200 years
- Temperature range
 - Commercial (C): 0°C to +70°C

DESCRIPTION

The Microchip Technology Inc. 24LC08B/16B are 8K and 16K bit Electrically Erasable PROMs in ISO modules for smart card applications. The device is organized as four or eight blocks of 256 x 8-bit memory with a 2-wire serial interface. The 24LC08B and 24LC16B also have a page-write capability for up to 16 bytes of data.

ISO MODULE LAYOUT

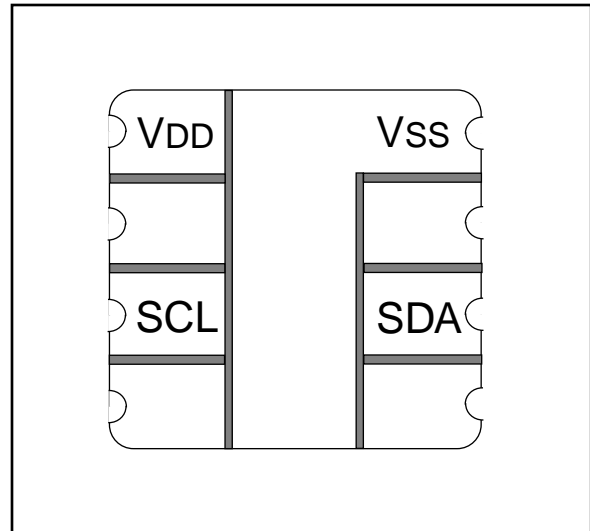

BLOCK DIAGRAM

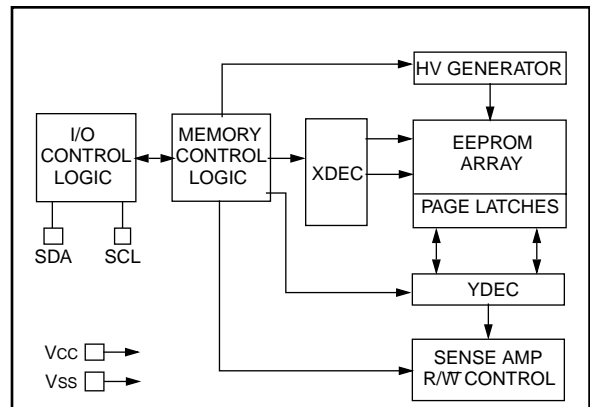

I²C is a trademark of Philips Corporation.

24LC08B/16B MODULES

1.0 ELECTRICAL CHARACTERISTICS

1.1 Maximum Ratings*

V_{CC}.....7.0V
 All inputs and outputs w.r.t. V_{SS}-0.6V to V_{CC} +1.0V
 Storage temperature -65°C to +150°C
 Ambient temp. with power applied..... -65°C to +125°C
 Soldering temperature of leads (10 seconds) +300°C
 ESD protection on all pins ≥ 4 kV

***Notice:** Stresses above those listed under "Maximum ratings" may cause permanent damage to the device. This is a stress rating only and functional operation of the device at those or any other conditions above those indicated in the operational listings of this specification is not implied. Exposure to maximum rating conditions for extended periods may affect device reliability.

TABLE 1-1: PIN FUNCTION TABLE

Name	Function
V _{SS}	Ground
SDA	Serial Data
SCL	Serial Clock
V _{CC}	+2.5V to 5.5V Power Supply

TABLE 1-2 DC CHARACTERISTICS

Parameter	Symbol	Min.	Max.	Units	Conditions
Commercial (C): T _{amb} = 0°C to +70°C, V _{CC} = 2.5V to 5.5V					
SCL and SDA pins:					
High level input voltage	V _{IH}	0.7 V _{CC}		V	(Note)
Low level input voltage	V _{IL}		0.3 V _{CC}	V	(Note)
Hysteresis of Schmitt trigger inputs	V _{HYS}	0.05 V _{CC}	—	V	V _{CC} ≥ 2.5V (Note)
Low level output voltage	V _{OL}		0.40	V	I _{OL} = 3.0 mA, V _{CC} = 4.5V I _{OL} = 2.1 mA, V _{CC} = 2.5V
Input leakage current	I _{LI}	-10	10	μA	V _{IN} = V _{CC} or V _{SS}
Output leakage current	I _{LO}	-10	10	μA	V _{OUT} = V _{CC} or V _{SS}
Pin capacitance (all inputs/outputs)	C _{IN} , C _{OUT}	—	10	pF	V _{CC} = 5.0V (Note) T _{amb} = 25°C, f = 1 MHz
Operating current	I _{CC} Write	—	3	mA	V _{CC} = 5.5V, SCL = 400 kHz
	I _{CC} Read	—	1	mA	V _{CC} = 5.5V, SCL = 400 kHz
Standby current	I _{CCS}	—	100	μA	V _{CC} = 5.5V, SDA = SCL = V _{CC}

Note: This parameter is periodically sampled and not 100% tested.

24LC08B/16B MODULES

TABLE 1-3 AC CHARACTERISTICS

All parameters apply across the specified operating ranges unless otherwise noted.		V _{CC} = 2.5V to 5.5V Commercial (C):				T _{amb} = 0°C to +70°C	
Parameter	Symbol	V _{CC} = 2.5V - 5.5V STD MODE		V _{CC} = 4.5V - 5.5V FAST MODE		Units	Remarks
		Min.	Max.	Min.	Max.		
Clock frequency	FCLK	—	100	—	400	kHz	
Clock high time	T _{HIGH}	4000	—	600	—	ns	
Clock low time	T _{LOW}	4700	—	1300	—	ns	
SDA and SCL rise time	T _R	—	1000	—	300	ns	(Note 1)
SDA and SCL fall time	T _F	—	300	—	300	ns	(Note 1)
START condition hold time	T _{HD:STA}	4000	—	600	—	ns	After this period the first clock pulse is generated
START condition setup time	T _{SU:STA}	4700	—	600	—	ns	Only relevant for repeated START condition
Data input hold time	T _{HD:DAT}	0	—	0	—	ns	(Note 2)
Data input setup time	T _{SU:DAT}	250	—	100	—	ns	
STOP condition setup time	T _{SU:STO}	4000	—	600	—	ns	
Output valid from clock	T _{AA}	—	3500	—	900	ns	(Note 2)
Bus free time	T _{BUF}	4700	—	1300	—	ns	Time the bus must be free before a new transmission can start
Output fall time from V _{IH} minimum to V _{IL} maximum	T _{OF}	—	250	20 + 0.1 C _B	250	ns	(Note 1), C _B ≤ 100 pF
Input filter spike suppression (SDA and SCL pins)	T _{SF}	—	50	—	50	ns	(Notes 1, 3)
Write cycle time	T _{WC}	—	10	—	10	ms	Byte or Page mode
Endurance		1M	—	1M	—	cycles	25°C, V _{CC} = 5.0V, Block Mode (Note 4)

Note 1: Not 100% tested. C_B = total capacitance of one bus line in pF.

2: As a transmitter, the device must provide an internal minimum delay time to bridge the undefined region (minimum 300 ns) of the falling edge of SCL to avoid unintended generation of START or STOP conditions.

3: The combined T_{SF} and V_{HYS} specifications are due to Schmitt trigger inputs which provide improved noise spike suppression. This eliminates the need for a TI specification for standard operation.

4: This parameter is not tested but guaranteed by characterization. For endurance estimates in a specific application, please consult the Total Endurance Model which can be obtained on our BBS or website.

FIGURE 1-1: BUS TIMING DATA

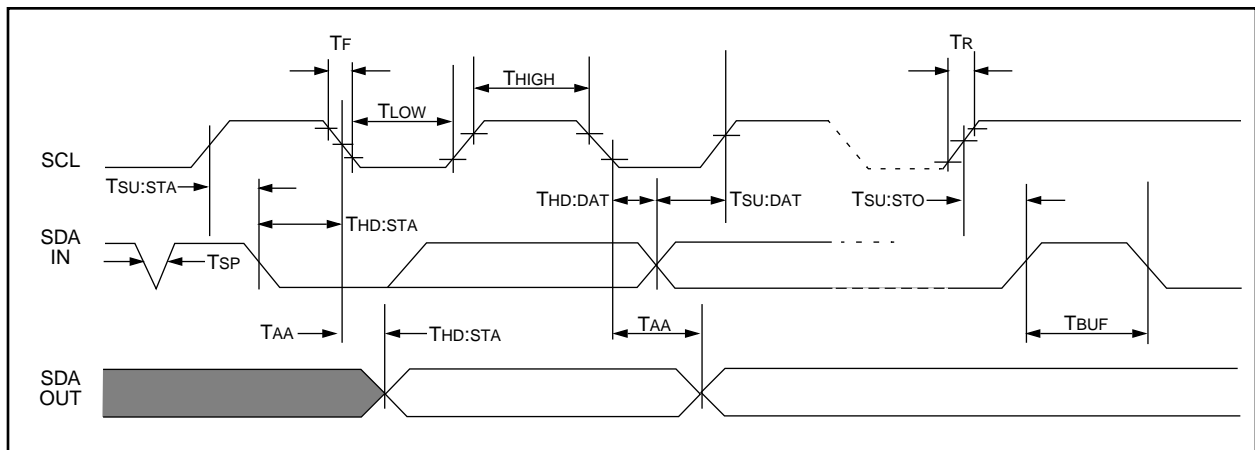

24LC08B/16B MODULES

2.0 PAD DESCRIPTIONS

2.1 SDA (Serial Data)

This is a Bi-directional pin used to transfer addresses and data into and data out of the device. It is an open drain terminal, therefore the SDA bus requires a pull-up resistor to Vcc (typical 10Ω).

For normal data transfer SDA is allowed to change only during SCL low. Changes during SCL high are reserved for indicating the START and STOP conditions.

2.2 SCL (Serial Clock)

This input is used to synchronize the data transfer from and to the device.

3.0 FUNCTIONAL DESCRIPTION

The 24LC08B/16B supports a Bi-directional 2-wire bus and data transmission protocol. A device that sends data onto the bus is defined as transmitter, and a device receiving data as receiver. The bus has to be controlled by a master device which generates the serial clock (SCL), controls the bus access, and generates the START and STOP conditions, while the 24LC08B/16B works as slave. Both, master and slave can operate as transmitter or receiver but the master device determines which mode is activated.

4.0 BUS CHARACTERISTICS

The following **bus protocol** has been defined:

- Data transfer may be initiated only when the bus is not busy.
- During data transfer, the data line must remain stable whenever the clock line is HIGH. Changes in the data line while the clock line is HIGH will be interpreted as a START or STOP condition.

Accordingly, the following bus conditions have been defined (Figure 5-2).

4.1 Bus not Busy (A)

Both data and clock lines remain HIGH.

4.2 Start Data Transfer (B)

A HIGH to LOW transition of the SDA line while the clock (SCL) is HIGH determines a START condition. All commands must be preceded by a START condition.

4.3 Stop Data Transfer (C)

A LOW to HIGH transition of the SDA line while the clock (SCL) is HIGH determines a STOP condition. All operations must be ended with a STOP condition.

4.4 Data Valid (D)

The state of the data line represents valid data when, after a START condition, the data line is stable for the duration of the HIGH period of the clock signal.

The data on the line must be changed during the LOW period of the clock signal. There is one clock pulse per bit of data.

Each data transfer is initiated with a START condition and terminated with a STOP condition. The number of the data bytes transferred between the START and STOP conditions is determined by the master device and is theoretically unlimited, although only the last 16 will be stored when doing a write operation. When an overwrite does occur it will replace data in a first in first out fashion.

24LC08B/16B MODULES

4.5 Acknowledge

Each receiving device, when addressed, is obliged to generate an acknowledge after the reception of each byte. The master device must generate an extra clock pulse which is associated with this acknowledge bit.

Note: The 24LC08B/16B does not generate any acknowledge bits if an internal programming cycle is in progress.

The device that acknowledges, has to pull down the SDA line during the acknowledge clock pulse in such a way that the SDA line is stable LOW during the HIGH period of the acknowledge related clock pulse. Of course, setup and hold times must be taken into account. During reads, a master must signal an end of data to the slave by NOT generating an acknowledge bit on the last byte that has been clocked out of the slave. In this case, the slave (24LC08B/16B) will leave the data line HIGH to enable the master to generate the STOP condition.

5.0 DEVICE ADDRESSING

A control byte is the first byte received following the start condition from the master device. The control byte consists of a 4-bit control code, for the 24LC08B/16B this is set as 1010 binary for read and write operations. The next three bits of the control byte are the block select bits (B2, B1, B0). They are used by the master device to select which of the eight 256 word blocks of memory are to be accessed. These bits are in effect the three most significant bits of the word address.

The last bit of the control byte defines the operation to be performed. When set to one a read operation is selected, when set to zero a write operation is selected. Following the start condition, the 24LC08B/16B monitors the SDA bus checking the device type identifier being transmitted, upon a 1010 code the slave device outputs an acknowledge signal on the SDA line. Depending on the state of the R/W bit, the 24LC08B/16B will select a read or write operation.

Operation	Control Code	Block Select	R/W
Read	1010	Block Address	1
Write	1010	Block Address	0

FIGURE 5-1: CONTROL BYTE ALLOCATION

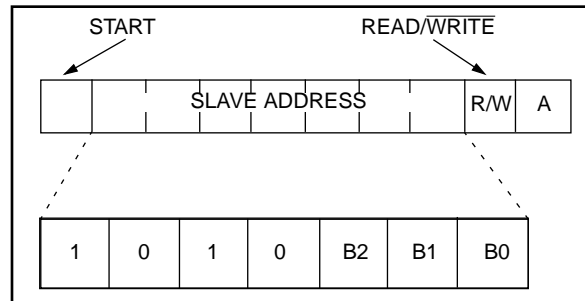
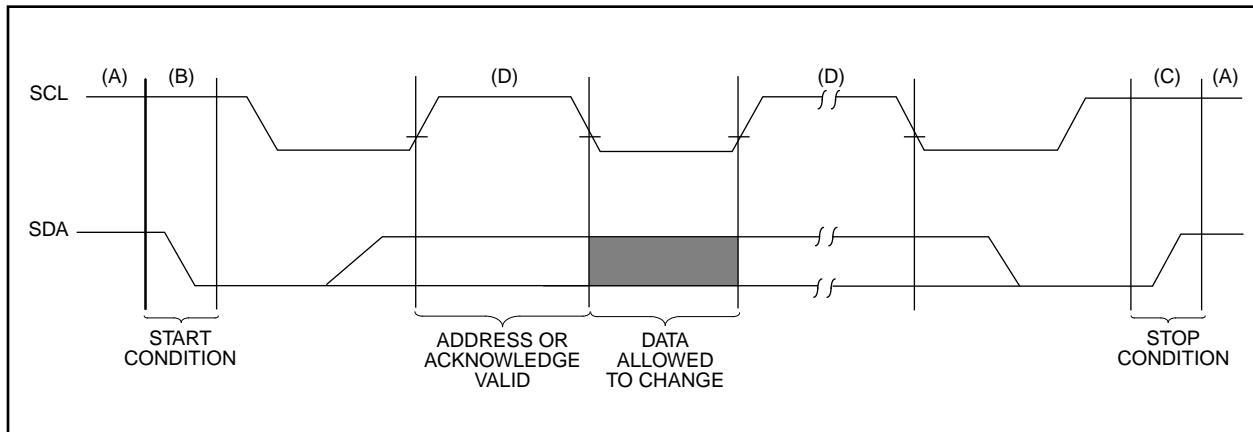

FIGURE 5-2: DATA TRANSFER SEQUENCE ON THE SERIAL BUS



24LC08B/16B MODULES

6.0 WRITE OPERATIONS

6.1 Byte Write

Following the start condition from the master, the device code (4 bits), the block address (3 bits), and the R/W bit which is a logic low is placed onto the bus by the master transmitter. This indicates to the addressed slave receiver that a byte with a word address will follow after it has generated an acknowledge bit during the ninth clock cycle. Therefore the next byte transmitted by the master is the word address and will be written into the address pointer of the 24LC08B/16B. After receiving another acknowledge signal from the 24LC08B/16B the master device will transmit the data word to be written into the addressed memory location. The 24LC08B/16B acknowledges again and the master generates a stop condition. This initiates the internal write cycle, and during this time the 24LC08B/16B will not generate acknowledge signals (Figure 6-1).

6.2 Page Write

The write control byte, word address and the first data byte are transmitted to the 24LC08B/16B in the same way as in a byte write. But instead of generating a stop condition the master transmits up to 16 data bytes to the 24LC08B/16B which are temporarily stored in the on-chip page buffer and will be written into the memory after the master has transmitted a stop condition. After the receipt of each word, the four lower order address pointer bits are internally incremented by one. The higher order seven bits of the word address remains constant. If the master should transmit more than 16 words prior to generating the stop condition, the address counter will roll over and the previously received data will be overwritten. As with the byte write operation, once the stop condition is received an internal write cycle will begin (Figure 6-2).

FIGURE 6-1: BYTE WRITE

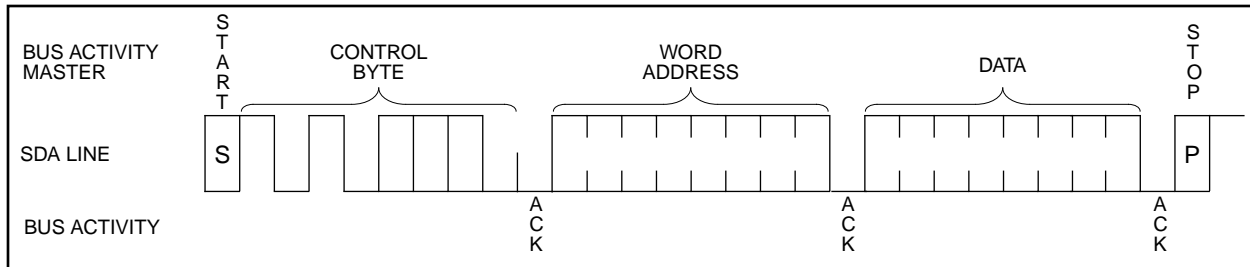
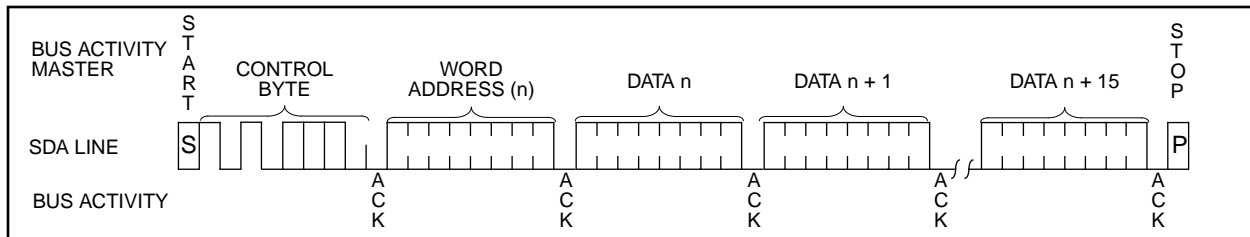

FIGURE 6-2: PAGE WRITE



7.0 ACKNOWLEDGE POLLING

Since the device will not acknowledge during a write cycle, this can be used to determine when the cycle is complete (this feature can be used to maximize bus throughput). Once the stop condition for a write command has been issued from the master, the device initiates the internally timed write cycle. ACK polling can be initiated immediately. This involves the master sending a start condition followed by the control byte for a write command ($R/\overline{W} = 0$). If the device is still busy with the write cycle, then no ACK will be returned. If the cycle is complete, then the device will return the ACK and the master can then proceed with the next read or write command. See Figure 7-1 for flow diagram.

FIGURE 7-1: ACKNOWLEDGE POLLING FLOW

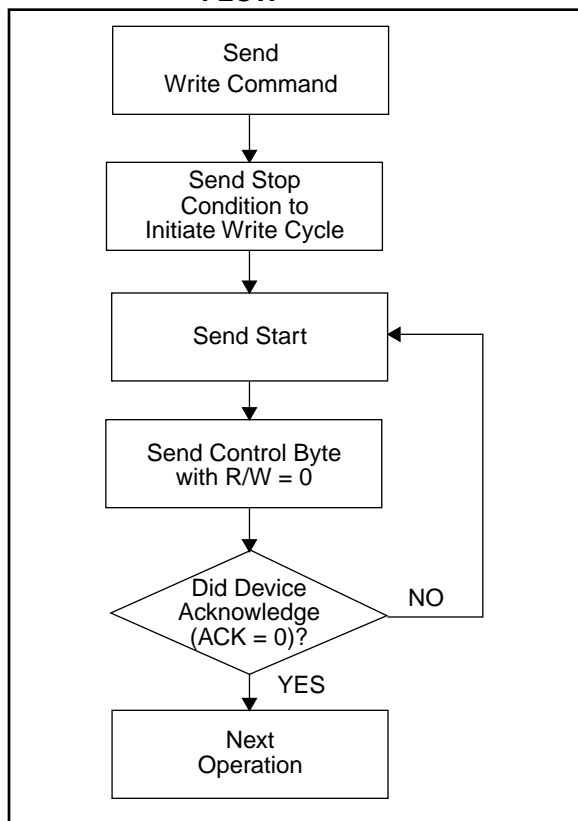

8.0 READ OPERATIONS

Read operations are initiated in the same way as write operations with the exception that the R/\overline{W} bit of the slave address is set to one. There are three basic types of read operations: current address read, random read, and sequential read.

8.1 Current Address Read

The 24LC08B/16B contains an address counter that maintains the address of the last word accessed, internally incremented by one. Therefore, if the previous access (either a read or write operation) was to address n , the next current address read operation would access data from address $n + 1$. Upon receipt of the slave address with R/\overline{W} bit set to one, the 24LC08B/16B issues an acknowledge and transmits the 8-bit data word. The master will not acknowledge the transfer but does generate a stop condition and the 24LC08B/16B discontinues transmission (Figure 8-1).

8.2 Random Read

Random read operations allow the master to access any memory location in a random manner. To perform this type of read operation, first the word address must be set. This is done by sending the word address to the 24LC08B/16B as part of a write operation. After the word address is sent, the master generates a start condition following the acknowledge. This terminates the write operation, but not before the internal address pointer is set. Then the master issues the control byte again but with the R/\overline{W} bit set to a one. The 24LC08B/16B will then issue an acknowledge and transmits the 8-bit data word. The master will not acknowledge the transfer but does generate a stop condition and the 24LC08B/16B discontinues transmission (Figure 8-2).

8.3 Sequential Read

Sequential reads are initiated in the same way as a random read except that after the 24LC08B/16B transmits the first data byte, the master issues an acknowledge as opposed to a stop condition in a random read. This directs the 24LC08B/16B to transmit the next sequentially addressed 8 bit word (Figure 8-3).

To provide sequential reads the 24LC08B/16B contains an internal address pointer which is incremented by one at the completion of each operation. This address pointer allows the entire memory contents to be serially read during one operation.

8.4 Noise Protection

The 24LC08B/16B employs a V_{cc} threshold detector circuit which disables the internal erase/write logic if the V_{cc} is below 1.5 volts at nominal conditions.

The SCL and SDA inputs have Schmitt trigger and filter circuits which suppress noise spikes to assure proper device operation even on a noisy bus.

24LC08B/16B MODULES

FIGURE 8-1: CURRENT ADDRESS READ

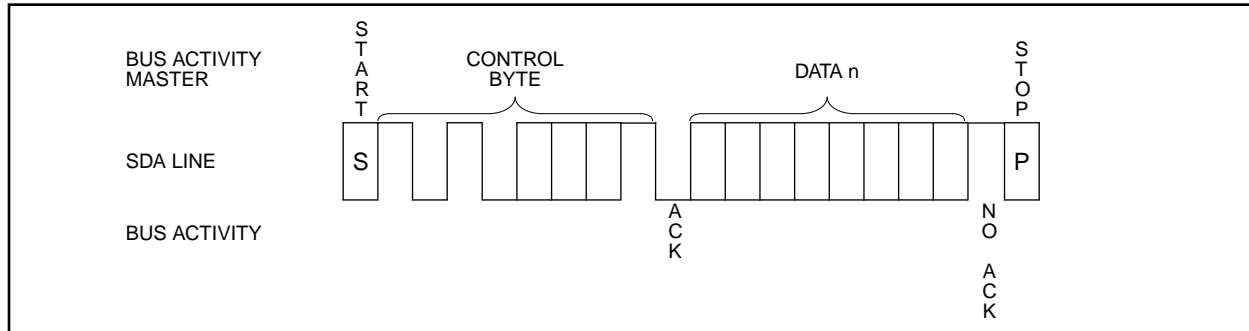

FIGURE 8-2: RANDOM READ

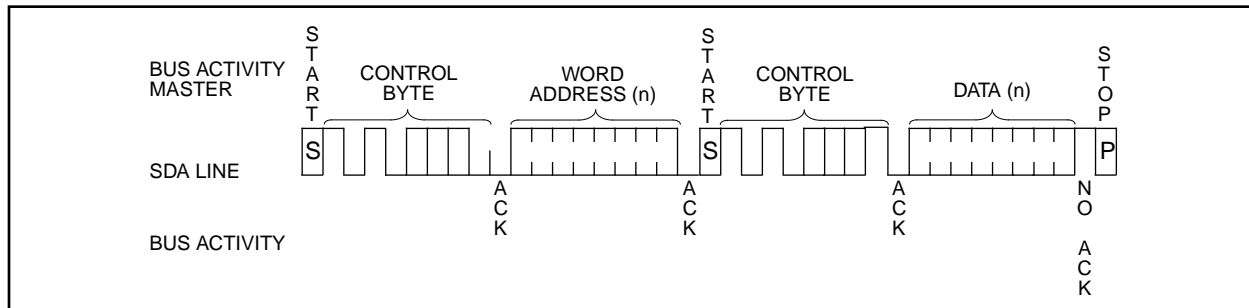
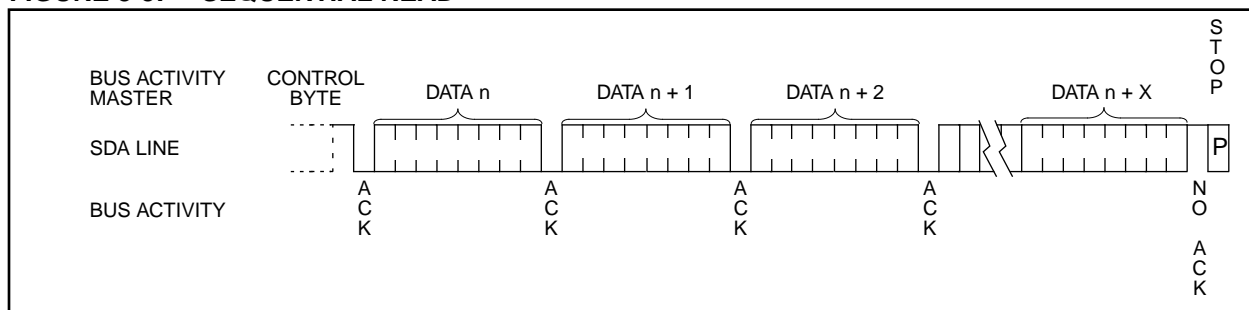

FIGURE 8-3: SEQUENTIAL READ



24LC08B/16B MODULES

9.0 SHIPPING METHOD

The micromodules will be shipped to customers in clear plastic trays. Each tray holds 150 modules, and the trays can be stacked in a manner similar to shipping die in waffle packs. A tray drawing with dimensions is shown in Figure 9-1.

FIGURE 9-1: TRAY DIMENSIONS

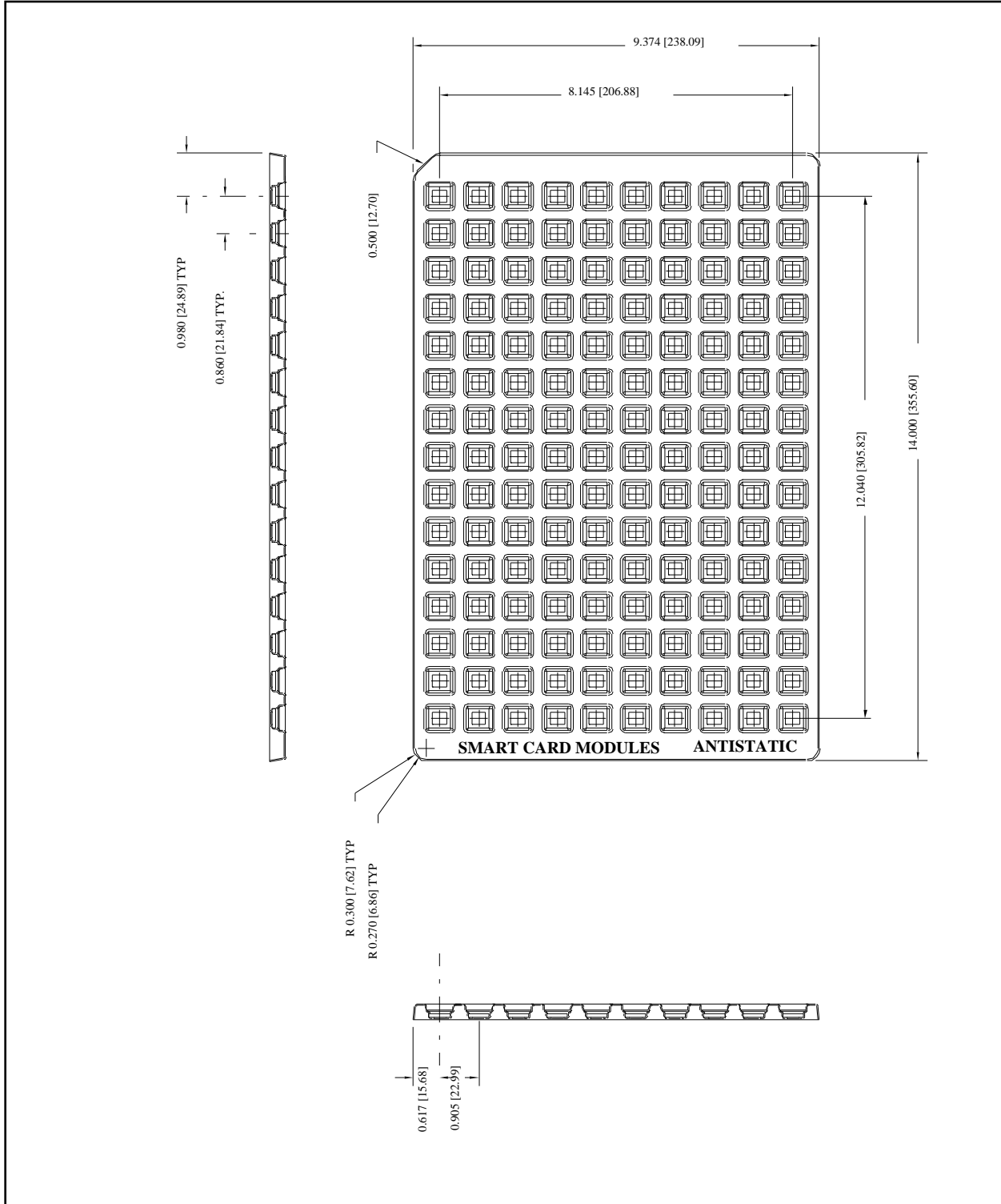

24LC08B/16B MODULES

FIGURE 9-2: MODULE DIMENSIONS

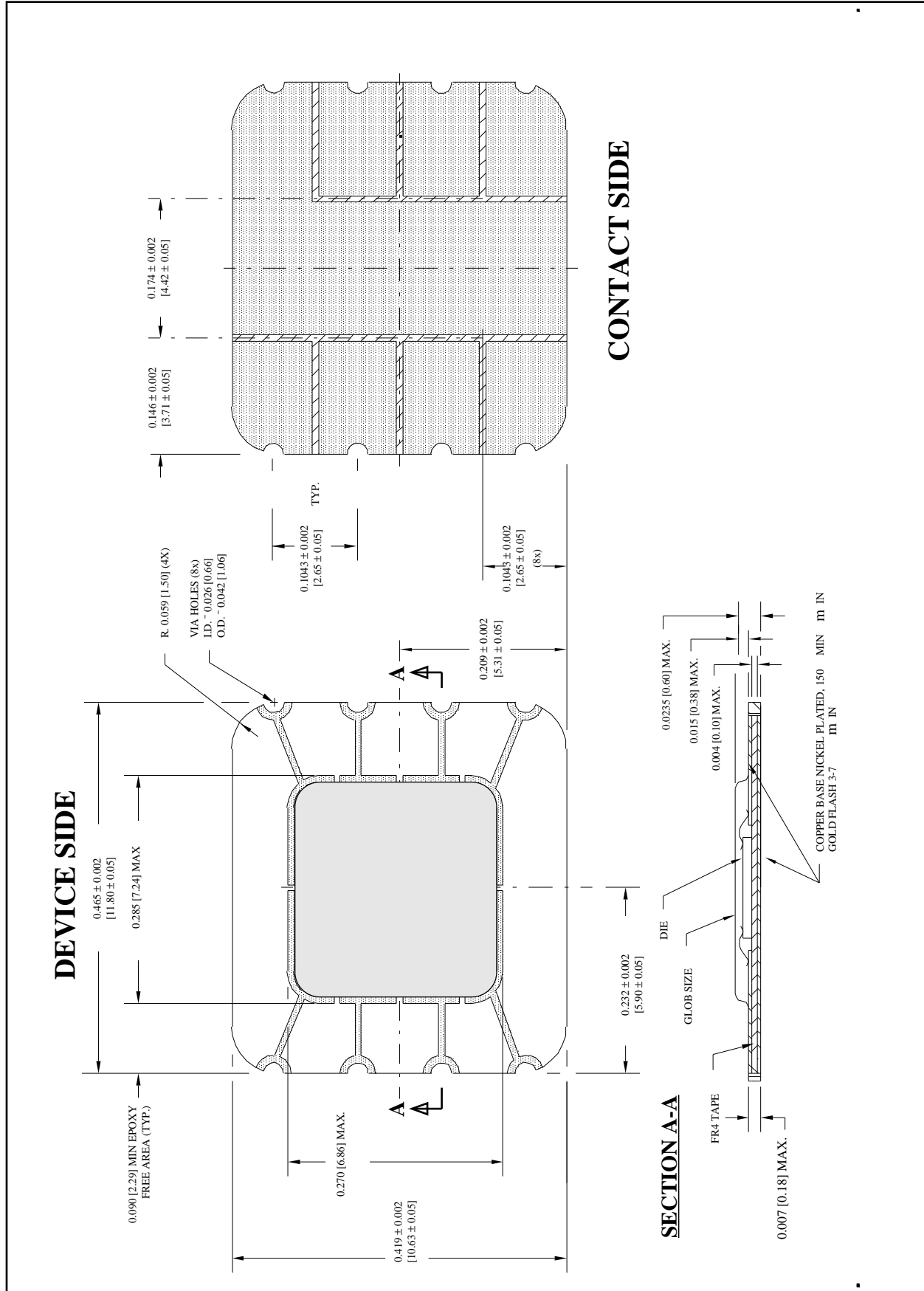

24LC08B/16B MODULES

24LC08B/16B MODULES PRODUCT IDENTIFICATION SYSTEM

To order or obtain information, e.g., on pricing or delivery, refer to the factory or the listed sales office.

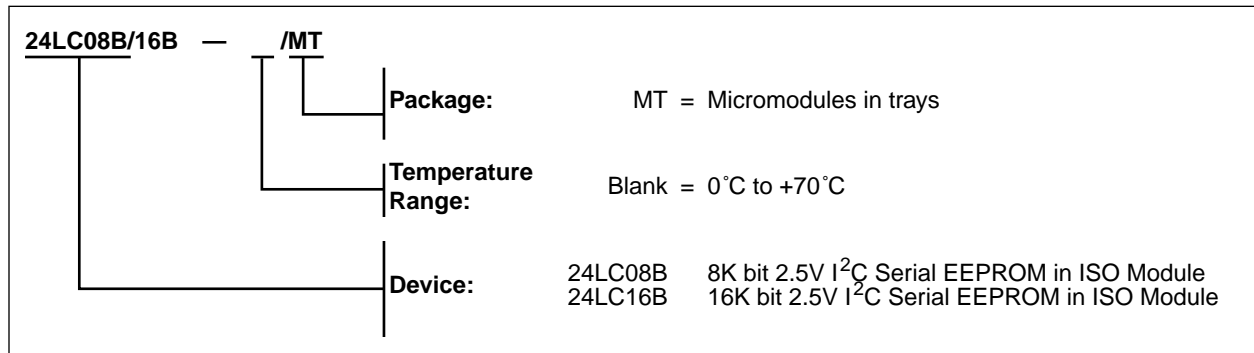

Sales and Support

Data Sheets

Products supported by a preliminary Data Sheet may have an errata sheet describing minor operational differences and recommended workarounds. To determine if an errata sheet exists for a particular device, please contact one of the following:

1. Your local Microchip sales office.
 2. The Microchip Corporate Literature Center U.S. FAX: (602) 786-7277.
 3. The Microchip's Bulletin Board, via your local CompuServe number (CompuServe membership NOT required).
- Please specify which device, revision of silicon and Data Sheet (include Literature #) you are using.



MICROCHIP

WORLDWIDE SALES & SERVICE

AMERICAS

Corporate Office

Microchip Technology Inc.
2355 West Chandler Blvd.
Chandler, AZ 85224-6199
Tel: 602-786-7200 Fax: 602-786-7277
Technical Support: 602 786-7627
Web: <http://www.microchip.com>

Atlanta

Microchip Technology Inc.
500 Sugar Mill Road, Suite 200B
Atlanta, GA 30350
Tel: 770-640-0034 Fax: 770-640-0307

Boston

Microchip Technology Inc.
5 Mount Royal Avenue
Marlborough, MA 01752
Tel: 508-480-9990 Fax: 508-480-8575

Chicago

Microchip Technology Inc.
333 Pierce Road, Suite 180
Itasca, IL 60143
Tel: 630-285-0071 Fax: 630-285-0075

Dallas

Microchip Technology Inc.
14651 Dallas Parkway, Suite 816
Dallas, TX 75240-8809
Tel: 972-991-7177 Fax: 972-991-8588

Dayton

Microchip Technology Inc.
Two Prestige Place, Suite 150
Miamisburg, OH 45342
Tel: 937-291-1654 Fax: 937-291-9175

Los Angeles

Microchip Technology Inc.
18201 Von Karman, Suite 1090
Irvine, CA 92612
Tel: 714-263-1888 Fax: 714-263-1338

New York

Microchip Technology Inc.
150 Motor Parkway, Suite 416
Hauppauge, NY 11788
Tel: 516-273-5305 Fax: 516-273-5335

San Jose

Microchip Technology Inc.
2107 North First Street, Suite 590
San Jose, CA 95131
Tel: 408-436-7950 Fax: 408-436-7955

Toronto

Microchip Technology Inc.
5925 Airport Road, Suite 200
Mississauga, Ontario L4V 1W1, Canada
Tel: 905-405-6279 Fax: 905-405-6253

ASIA/PACIFIC

Hong Kong

Microchip Asia Pacific
RM 3801B, Tower Two
Metroplaza
223 Hing Fong Road
Kwai Fong, N.T., Hong Kong
Tel: 852-2-401-1200 Fax: 852-2-401-3431

India

Microchip Technology Inc.
India Liaison Office
No. 6, Legacy, Convent Road
Bangalore 560 025, India
Tel: 91-80-229-4036 Fax: 91-80-559-9840

Korea

Microchip Technology Korea
168-1, Youngbo Bldg. 3 Floor
Samsung-Dong, Kangnam-Ku
Seoul, Korea
Tel: 82-2-554-7200 Fax: 82-2-558-5934

Shanghai

Microchip Technology
RM 406 Shanghai Golden Bridge Bldg.
2077 Yan'an Road West, Hong Qiao District
Shanghai, PRC 200335
Tel: 86-21-6275-5700
Fax: 86 21-6275-5060

Singapore

Microchip Technology Taiwan
Singapore Branch
200 Middle Road
#07-02 Prime Centre
Singapore 188980
Tel: 65-334-8870 Fax: 65-334-8850

Taiwan, R.O.C

Microchip Technology Taiwan
10F-1C 207
Tung Hua North Road
Taipei, Taiwan, ROC
Tel: 886 2-717-7175 Fax: 886-2-545-0139

EUROPE

United Kingdom

Arizona Microchip Technology Ltd.
Unit 6, The Courtyard
Meadow Bank, Furlong Road
Bourne End, Buckinghamshire SL8 5AJ
Tel: 44-1628-851077 Fax: 44-1628-850259

France

Arizona Microchip Technology SARL
Zone Industrielle de la Bonde
2 Rue du Buisson aux Fraises
91300 Massy, France
Tel: 33-1-69-53-63-20 Fax: 33-1-69-30-90-79

Germany

Arizona Microchip Technology GmbH
Gustav-Heinemann-Ring 125
D-81739 München, Germany
Tel: 49-89-627-144 0 Fax: 49-89-627-144-44

Italy

Arizona Microchip Technology SRL
Centro Direzionale Colleoni
Palazzo Taurus 1 V. Le Colleoni 1
20041 Agrate Brianza
Milan, Italy
Tel: 39-39-6899939 Fax: 39-39-6899883

JAPAN

Microchip Technology Intl. Inc.
Benex S-1 6F
3-18-20, Shinyokohama
Kohoku-Ku, Yokohama-shi
Kanagawa 222 Japan
Tel: 81-45-471- 6166 Fax: 81-45-471-6122

8/29/97

All rights reserved. © 1997, Microchip Technology Incorporated, USA. 9/97 Printed on recycled paper.

Information contained in this publication regarding device applications and the like is intended for suggestion only and may be superseded by updates. No representation or warranty is given and no liability is assumed by Microchip Technology Incorporated with respect to the accuracy or use of such information, or infringement of patents or other intellectual property rights arising from such use or otherwise. Use of Microchip's products as critical components in life support systems is not authorized except with express written approval by Microchip. No licenses are conveyed, implicitly or otherwise, under any intellectual property rights. The Microchip logo and name are registered trademarks of Microchip Technology Inc. in the U.S.A. and other countries. All rights reserved. All other trademarks mentioned herein are the property of their respective companies.