

## 1 $\mu$ A Low Dropout Positive Voltage Regulator

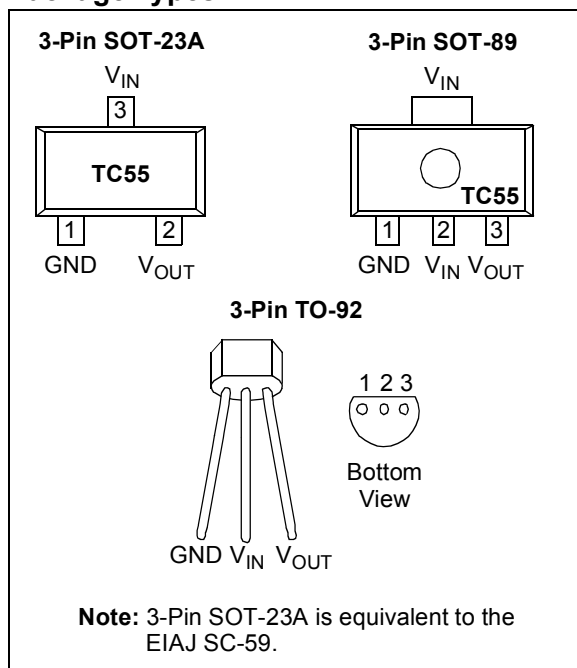
### Features

- Low Dropout Voltage: 120 mV (typ) at 100 mA, 380 mV (typ) at 200 mA
- High Output Current: 250 mA ( $V_{OUT} = 5.0V$ )
- High Accuracy Output Voltage:  $\pm 2\%$  (max) ( $\pm 1\%$  Semi-Custom Version)
- Low Power Consumption: 1.1  $\mu$ A (typ)
- Low Temperature Drift:  $\pm 100$  ppm/ $^{\circ}C$  (typ)
- Excellent Line Regulation: 0.2%/V (typ)
- Package Options: 3-Pin SOT-23A, 3-Pin SOT-89 and 3-Pin TO-92
- Short-Circuit Protection
- Standard Output Voltage Options: 1.2V, 1.8V, 2.5V, 3.0V, 3.3V, 5.0V

### Applications

- Battery-Powered Devices
- Cameras and Portable Video Equipment
- Pagers and Cellular Phones
- Solar Powered Instruments
- Consumer Products

### Package Types



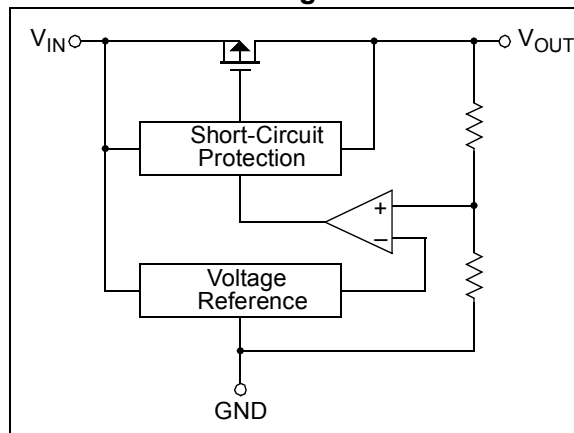
### General Description

The TC55 Series is a collection of CMOS low dropout, positive voltage regulators that can source up to 250 mA of current, with an extremely low input-output voltage differential of 380 mV (typ) at 200 mA.

The TC55's low dropout voltage, combined with the low current consumption of only 1.1  $\mu$ A (typ), makes it ideal for battery operation. The low voltage differential (dropout voltage) extends the battery operating lifetime. It also permits high currents in small packages when operated with minimum  $V_{IN} - V_{OUT}$  differentials.

The circuit also incorporates short-circuit protection to ensure maximum reliability.

### Functional Block Diagram



# TC55

## 1.0 ELECTRICAL CHARACTERISTICS

### Absolute Maximum Ratings†

Input Voltage .....	+12V
Output Current (Continuous).....	$P_D/(V_{IN} - V_{OUT})$ mA
Output Current (peak) .....	500 mA
Output Voltage .....	$(V_{SS} - 0.3V)$ to $(V_{IN} + 0.3V)$
Continuous Power Dissipation:	
3-Pin SOT-23A .....	240 mW
3-Pin SOT-89 .....	500 mW
3-Pin TO-92 .....	440 mW

† Stresses above those listed under "Absolute Maximum Ratings" may cause permanent damage to the device. These are stress ratings only and functional operation of the device at these or any other conditions above those indicated in the operation sections of the specifications is not implied. Exposure to Absolute Maximum Rating conditions for extended periods may affect device reliability.

### PIN FUNCTION TABLE

Symbol	Description
GND	Ground Terminal
$V_{OUT}$	Regulated Voltage Output
$V_{IN}$	Unregulated Supply Input

### TC55RP50: ELECTRICAL CHARACTERISTICS

Electrical Specifications: Unless otherwise specified, $V_{OUT}(S) = 5.0V$ , $T_A = +25^\circ C$ (see Note 1).						
Parameters	Sym	Min	Typ	Max	Units	Conditions
Output Voltage	$V_{OUT}(A)$	— 4.90	— 5.0	— 5.10	V	$I_{OUT} = 40$ mA $V_{IN} = 6.0V$
Maximum Output Current	$I_{OUTMAX}$	250	—	—	mA	$V_{IN} = 6.0V$ , $V_{OUT}(A) \geq 4.5V$
Load Regulation	$\Delta V_{OUT}$	—	40	80	mV	$V_{IN} = 6.0V$ , $1$ mA $\leq I_{OUT} \leq 100$ mA
I/O Voltage Difference	$V_{DIF}$	— —	120 380	300 600	mV	$I_{OUT} = 100$ mA $I_{OUT} = 200$ mA
Current Consumption	$I_{SS}$	—	1.1	3.0	$\mu A$	$V_{IN} = 6.0V$
Voltage Regulation	$\frac{V_{OUT}(A) \cdot 100}{\Delta V_{IN} \cdot V_{OUT}(S)}$	—	0.2	0.3	%/V	$I_{OUT} = 40$ mA, $6.0V \leq V_{IN} \leq 10.0V$
Input Voltage	$V_{IN}$	—	—	10	V	
Temperature Coefficient of Output Voltage	$\frac{\Delta V_{OUT}(A) \cdot 10^6}{V_{OUT}(S) \cdot \Delta T_A}$	—	$\pm 100$	—	ppm/ $^\circ C$	$I_{OUT} = 40$ mA, $-40^\circ C \leq T_A \leq +85^\circ C$
Long-Term Stability		—	0.5	—	%	$T_A = +125^\circ C$ , 1000 Hours

**Note 1:**  $V_{OUT}(S)$ : Preset value of output voltage;  $V_{OUT}(A)$ : Actual value of output voltage;  $V_{DIF}$ : Definition of I/O voltage difference =  $\{V_{IN1} - V_{OUT}(A)\}$ ;  $V_{OUT}(A)$ : Output voltage when  $I_{OUT}$  is fixed and  $V_{IN} = V_{OUT}(S) + 1.0V$ ;  $V_{IN1}$ : Input voltage when the output voltage is 98%  $V_{OUT}(A)$ .

### TC55RP40: ELECTRICAL CHARACTERISTICS

Electrical Specifications: Unless otherwise specified, $V_{OUT}(S) = 4.0V$ , $T_A = +25^\circ C$ (see Note 1).						
Parameters	Sym	Min	Typ	Max	Units	Conditions
Output Voltage	$V_{OUT}(A)$	— 3.92	— 4.0	— 4.08	V	$I_{OUT} = 40$ mA $V_{IN} = 5.0V$
Maximum Output Current	$I_{OUTMAX}$	200	—	—	mA	$V_{IN} = 5.0V$ , $V_{OUT}(A) \geq 3.6V$
Load Regulation	$\Delta V_{OUT}$	—	45	90	mV	$V_{IN} = 5.0V$ , $1$ mA $\leq I_{OUT} \leq 100$ mA
I/O Voltage Difference	$V_{DIF}$	— —	170 400	330 630	mV	$I_{OUT} = 100$ mA $I_{OUT} = 200$ mA
Current Consumption	$I_{SS}$	—	1.0	2.9	$\mu A$	$V_{IN} = 5.0V$
Voltage Regulation	$\frac{V_{OUT}(A) \cdot 100}{\Delta V_{IN} \cdot V_{OUT}(S)}$	—	0.2	0.3	%/V	$I_{OUT} = 40$ mA, $5.0V \leq V_{IN} \leq 10.0V$
Input Voltage	$V_{IN}$	—	—	10	V	
Temperature Coefficient of Output Voltage	$\frac{\Delta V_{OUT}(A) \cdot 10^6}{V_{OUT}(S) \cdot \Delta T_A}$	—	$\pm 100$	—	ppm/ $^\circ C$	$I_{OUT} = 40$ mA, $-40^\circ C \leq T_A \leq +85^\circ C$
Long-Term Stability		—	0.5	—	%	$T_A = +125^\circ C$ , 1000 Hours

**Note 1:**  $V_{OUT}(S)$ : Preset value of output voltage;  $V_{OUT}(A)$ : Actual value of output voltage;  $V_{DIF}$ : Definition of I/O voltage difference =  $\{V_{IN1} - V_{OUT}(A)\}$ ;  $V_{OUT}(A)$ : Output voltage when  $I_{OUT}$  is fixed and  $V_{IN} = V_{OUT}(S) + 1.0V$ ;  $V_{IN1}$ : Input voltage when the output voltage is 98%  $V_{OUT}(A)$ .

## TC55RP33: ELECTRICAL CHARACTERISTICS

Electrical Specifications: Unless otherwise specified, $V_{OUT(S)} = 3.3V$ , $T_A = +25^{\circ}C$ (see Note 1).						
Parameters	Sym	Min	Typ	Max	Units	Conditions
Output Voltage	$V_{OUT(A)}$	— 3.23	— 3.30	— 3.37	V	$I_{OUT} = 40\text{ mA}$ $V_{IN} = 4.3V$
Maximum Output Current	$I_{OUTMAX}$	150	—	—	mA	$V_{IN} = 4.3V$ , $V_{OUT(A)} \geq 3.0V$
Load Regulation	$\Delta V_{OUT}$	—	45	90	mV	$V_{IN} = 4.3V$ , $1\text{ mA} \leq I_{OUT} \leq 80\text{ mA}$
I/O Voltage Difference	$V_{DIF}$	—	180 400	360 700	mV	$I_{OUT} = 80\text{ mA}$ $I_{OUT} = 160\text{ mA}$
Current Consumption	$I_{SS}$	—	1.0	2.9	$\mu A$	$V_{IN} = 4.3V$
Voltage Regulation	$\frac{V_{OUT(A)} \cdot 100}{\Delta V_{IN} \cdot V_{OUT(S)}}$	—	0.2	0.3	%/V	$I_{OUT} = 40\text{ mA}$ , $4.3V \leq I_{OUT} \leq 10.0V$
Input Voltage	$V_{IN}$	—	—	10	V	
Temperature Coefficient of Output Voltage	$\frac{\Delta V_{OUT(A)} \cdot 10^6}{V_{OUT(S)} \cdot \Delta T_A}$	—	$\pm 100$	—	ppm/ $^{\circ}C$	$I_{OUT} = 40\text{ mA}$ , $-40^{\circ}C \leq T_A \leq +85^{\circ}C$
Long-Term Stability		—	0.5	—	%	$T_A = +125^{\circ}C$ , 1,000 Hours

**Note 1:**  $V_{OUT(S)}$ : Preset value of output voltage;  $V_{OUT(A)}$ : Actual value of output voltage;  $V_{DIF}$ : Definition of I/O voltage difference =  $\{V_{IN1} - V_{OUT(A)}\}$ ;  $V_{OUT(A)}$ : Output voltage when  $I_{OUT}$  is fixed and  $V_{IN} = V_{OUT(S)} + 1.0V$ ;  $V_{IN1}$ : Input voltage when the output voltage is 98%  $V_{OUT(A)}$ .

## TC55RP30: ELECTRICAL CHARACTERISTICS

Electrical Specifications: Unless otherwise specified, $V_{OUT(S)} = 3.0V$ , $T_A = +25^{\circ}C$ (see Note 1).						
Parameters	Sym	Min	Typ	Max	Units	Conditions
Output Voltage	$V_{OUT(A)}$	— 2.94	— 3.0	— 3.06	V	$I_{OUT} = 40\text{ mA}$ $V_{IN} = 4.0V$
Maximum Output Current	$I_{OUTMAX}$	150	—	—	mA	$V_{IN} = 4.0V$ , $V_{OUT(A)} \geq 2.7V$
Load Regulation	$\Delta V_{OUT}$	—	45	90	mV	$V_{IN} = 4.0V$ , $1\text{ mA} \leq I_{OUT} \leq 80\text{ mA}$
I/O Voltage Difference	$V_{DIF}$	—	180 400	360 700	mV	$I_{OUT} = 80\text{ mA}$ $I_{OUT} = 160\text{ mA}$
Current Consumption	$I_{SS}$	—	0.9	2.8	$\mu A$	$V_{IN} = 4.0V$
Voltage Regulation	$\frac{V_{OUT(A)} \cdot 100}{\Delta V_{IN} \cdot V_{OUT(S)}}$	—	0.2	0.3	%/V	$I_{OUT} = 40\text{ mA}$ , $4.0V \leq V_{IN} \leq 10.0V$
Input Voltage	$V_{IN}$	—	—	10	V	
Temperature Coefficient of Output Voltage	$\frac{\Delta V_{OUT(A)} \cdot 10^6}{V_{OUT(S)} \cdot \Delta T_A}$	—	$\pm 100$	—	ppm/ $^{\circ}C$	$I_{OUT} = 40\text{ mA}$ , $-40^{\circ}C \leq T_A \leq +85^{\circ}C$
Long-Term Stability		—	0.5	—	%	$T_A = +125^{\circ}C$ , 1000 Hours

**Note 1:**  $V_{OUT(S)}$ : Preset value of output voltage;  $V_{OUT(A)}$ : Actual value of output voltage;  $V_{DIF}$ : Definition of I/O voltage difference =  $\{V_{IN1} - V_{OUT(A)}\}$ ;  $V_{OUT(A)}$ : Output voltage when  $I_{OUT}$  is fixed and  $V_{IN} = V_{OUT(S)} + 1.0V$ ;  $V_{IN1}$ : Input voltage when the output voltage is 98%  $V_{OUT(A)}$ .

# TC55

## TC55RP25: ELECTRICAL CHARACTERISTICS

Electrical Specifications: Unless otherwise specified, $V_{OUT(S)} = 2.5V$ , $T_A = +25^\circ C$ (see Note 1).						
Parameters	Sym	Min	Typ	Max	Units	Conditions
Output Voltage	$V_{OUT(A)}$	— 2.45	— 2.5	— 2.55	V	$I_{OUT} = 40\text{ mA}$ $V_{IN} = 3.5V$
Maximum Output Current	$I_{OUTMAX}$	125	—	—	mA	$V_{IN} = 3.5V$ , $V_{OUT(A)} \geq 2.25V$
Load Regulation	$\Delta V_{OUT}$	—	45	90	mV	$V_{IN} = 3.5V$ , $1\text{ mA} \leq I_{OUT} \leq 60\text{ mA}$
I/O Voltage Difference	$V_{DIF}$	—	180 400	360 700	mV	$I_{OUT} = 60\text{ mA}$ $I_{OUT} = 120\text{ mA}$
Current Consumption	$I_{SS}$	—	1.0	2.8	$\mu A$	$V_{IN} = 3.5V$
Voltage Regulation	$\frac{V_{OUT(A)} \cdot 100}{\Delta V_{IN} \cdot V_{OUT(S)}}$	—	0.2	0.3	%/V	$I_{OUT} = 40\text{ mA}$ , $3.5V \leq I_{OUT} \leq 10.0V$
Input Voltage	$V_{IN}$	—	—	10	V	
Temperature Coefficient of Output Voltage	$\frac{\Delta V_{OUT(A)} \cdot 10^6}{V_{OUT(S)} \cdot \Delta T_A}$	—	$\pm 100$	—	ppm/ $^\circ C$	$I_{OUT} = 40\text{ mA}$ , $-30^\circ C \leq T_A \leq +80^\circ C$
Long-Term Stability		—	0.5	—	%	$T_A = +125^\circ C$ , 1,000 Hours

**Note 1:**  $V_{OUT(S)}$ : Preset value of output voltage;  $V_{OUT(A)}$ : Actual value of output voltage;  $V_{DIF}$ : Definition of I/O voltage difference =  $\{V_{IN1} - V_{OUT(A)}\}$ ;  $V_{OUT(A)}$ : Output voltage when  $I_{OUT}$  is fixed and  $V_{IN} = V_{OUT(S)} + 1.0V$ ;  $V_{IN1}$ : Input voltage when the output voltage is 98%  $V_{OUT(A)}$ .

## TC55RP18: ELECTRICAL CHARACTERISTICS

Electrical Specifications: Unless otherwise specified, $V_{OUT(S)} = 1.8V$ , $T_A = +25^\circ C$ (see Note 1).						
Parameters	Sym	Min	Typ	Max	Units	Conditions
Output Voltage	$V_{OUT(A)}$	— 1.764	— 1.8	— 1.836	V	$I_{OUT} = 0.5\text{ mA}$ $V_{IN} = 2.8V$
Maximum Output Current	$I_{OUTMAX}$	110	—	—	mA	$V_{IN} = 2.8V$ , $V_{OUT(A)} \geq 1.62V$
Load Regulation	$\Delta V_{OUT}$	—	—	30	mV	$V_{IN} = 2.8V$ , $1\text{ mA} \leq I_{OUT} \leq 30\text{ mA}$
I/O Voltage Difference	$V_{DIF}$	—	—	300	mV	$I_{OUT} = 0.5\text{ mA}$
Current Consumption	$I_{SS}$	—	—	3.0	$\mu A$	$V_{IN} = 2.8V$
Voltage Regulation	$\frac{V_{OUT(A)} \cdot 100}{\Delta V_{IN} \cdot V_{OUT(S)}}$	—	—	0.25	%/V	$I_{OUT} = 0.5\text{ mA}$ , $2.8V \leq I_{OUT} \leq 10.0V$
Input Voltage	$V_{IN}$	—	—	6.0	V	
Temperature Coefficient of Output Voltage	$\frac{\Delta V_{OUT(A)} \cdot 10^6}{V_{OUT(S)} \cdot \Delta T_A}$	—	$\pm 100$	—	ppm/ $^\circ C$	$I_{OUT} = 0.5\text{ mA}$ , $-30^\circ C \leq T_A \leq +80^\circ C$
Long-Term Stability		—	0.5	—	%	$T_A = +125^\circ C$ , 1,000 Hours

**Note 1:**  $V_{OUT(S)}$ : Preset value of output voltage;  $V_{OUT(A)}$ : Actual value of output voltage;  $V_{DIF}$ : Definition of I/O voltage difference =  $\{V_{IN1} - V_{OUT(A)}\}$ ;  $V_{OUT(A)}$ : Output voltage when  $I_{OUT}$  is fixed and  $V_{IN} = V_{OUT(S)} + 1.0V$ ;  $V_{IN1}$ : Input voltage when the output voltage is 98%  $V_{OUT(A)}$ .

## TC55RP12: ELECTRICAL CHARACTERISTICS

Electrical Specifications: Unless otherwise specified, $V_{OUT(S)} = 1.2V$ , $T_A = +25^\circ C$ (see Note 1).						
Parameters	Sym	Min	Typ	Max	Units	Conditions
Output Voltage	$V_{OUT(A)}$	— 1.176	— 1.200	— 1.224	V	$I_{OUT} = 0.5\text{ mA}$ $V_{IN} = 2.2V$
Maximum Output Current	$I_{OUTMAX}$	50	—	—	mA	$V_{IN} = 2.2V$ , $V_{OUT(A)} \geq 1.08V$
Load Regulation	$\Delta V_{OUT}$	—	—	30	mV	$V_{IN} = 2.2V$ , $1\text{ mA} \leq I_{OUT} \leq 30\text{ mA}$
I/O Voltage Difference	$V_{DIF}$	—	—	300	mV	$I_{OUT} = 0.5\text{ mA}$
Current Consumption	$I_{SS}$	—	—	3.0	$\mu A$	$V_{IN} = 2.2V$
Voltage Regulation	$\frac{V_{OUT(A)} \cdot 100}{\Delta V_{IN} \cdot V_{OUT(S)}}$	—	—	0.25	%/V	$I_{OUT} = 0.5$ , $2.2V \leq I_{OUT} \leq 10.0V$
Input Voltage	$V_{IN}$	—	—	6.0	V	
Temperature Coefficient of Output Voltage	$\frac{\Delta V_{OUT(A)} \cdot 10^6}{V_{OUT(S)} \cdot \Delta T_A}$	—	$\pm 100$	—	ppm/ $^\circ C$	$I_{OUT} = 0.5\text{ mA}$ , $-30^\circ C \leq T_A \leq +80^\circ C$
Long-Term Stability		—	0.5	—	%	$T_A = +125^\circ C$ , 1,000 Hours

**Note 1:**  $V_{OUT(S)}$ : Preset value of output voltage;  $V_{OUT(A)}$ : Actual value of output voltage;  $V_{DIF}$ : Definition of I/O voltage difference =  $\{V_{IN1} - V_{OUT(A)}\}$ ;  $V_{OUT(A)}$ : Output voltage when  $I_{OUT}$  is fixed and  $V_{IN} = V_{OUT(S)} + 1.0V$ ;  $V_{IN1}$ : Input voltage when the output voltage is 98%  $V_{OUT(A)}$ .

## TEMPERATURE CHARACTERISTICS

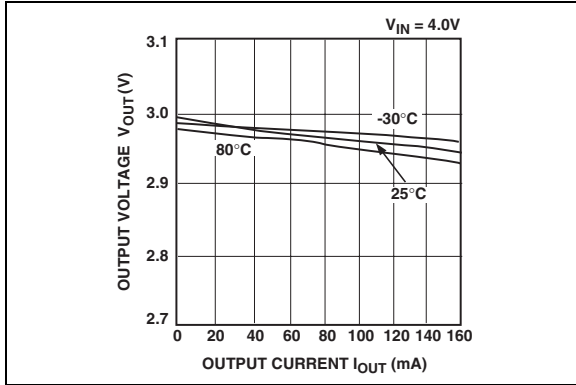
Electrical Specifications: Unless otherwise specified, $V_{OUT(S)} = 5.0V$ , $T_A = +25^\circ C$ .						
Parameters	Sym	Min	Typ	Max	Units	Conditions
<b>Temperature Ranges</b>						
Specified Temperature Range (E)	$T_A$	-40	—	+85	$^\circ C$	
Storage Temperature Range	$T_A$	-65	—	+150	$^\circ C$	
<b>Package Thermal Resistances</b>						
Thermal Resistance, 3L-SOT-23A	$\theta_{JA}$	—	359	—	$^\circ C/W$	
Thermal Resistance, 3L-SOT-89	$\theta_{JA}$	—	110	—	$^\circ C/W$	When mounted on 1 square inch of copper
Thermal Resistance, 3L-TO-92	$\theta_{JA}$	—	131.9	—	$^\circ C/W$	

# TC55

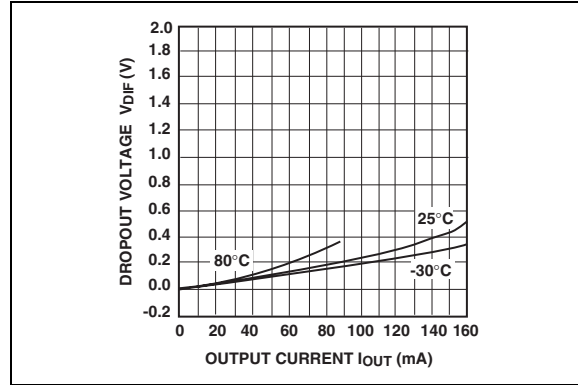
## 2.0 TYPICAL PERFORMANCE CURVES

**Note:** The graphs and tables provided following this note are a statistical summary based on a limited number of samples and are provided for informational purposes only. The performance characteristics listed herein are not tested or guaranteed. In some graphs or tables, the data presented may be outside the specified operating range (e.g., outside specified power supply range) and therefore outside the warranted range.

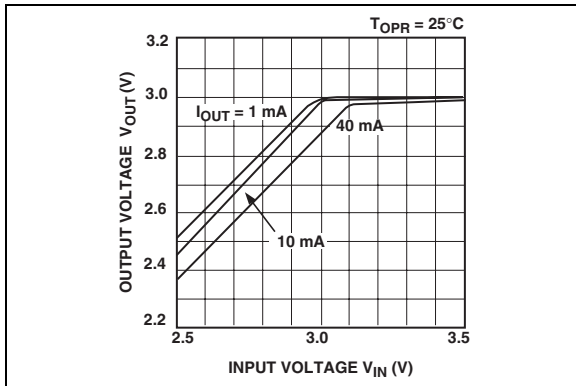
**Notes:** Unless otherwise specified,  $V_{OUT(S)} = 3.0V, 5.0V$ ,  $T_A = +25^\circ C$ ,  $C_{IN} = 1 \mu F$  Tantalum,  $C_{OUT} = 1 \mu F$  Tantalum.



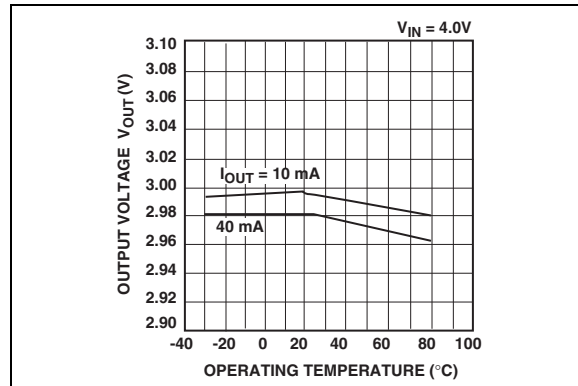
**FIGURE 2-1:** Output Voltage vs. Output Current (TC55RP3002).



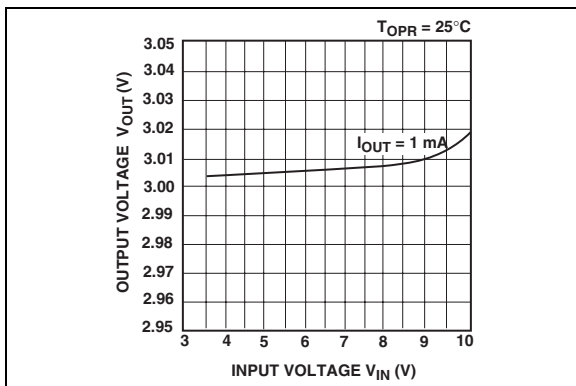
**FIGURE 2-4:** Dropout Voltage vs. Output Current (TC55RP3002).



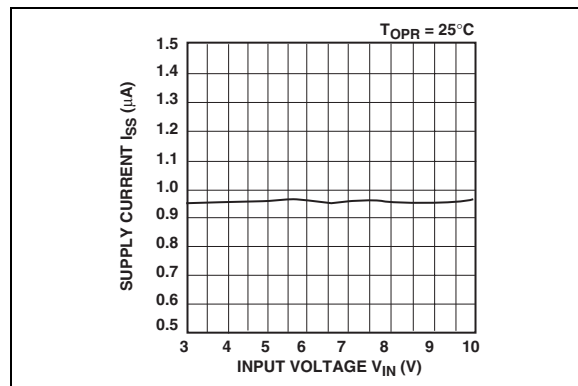
**FIGURE 2-2:** Output Voltage vs. Input Voltage (TC55RP3002).



**FIGURE 2-5:** Output Voltage vs. Operating Temperature (TC55RP3002).

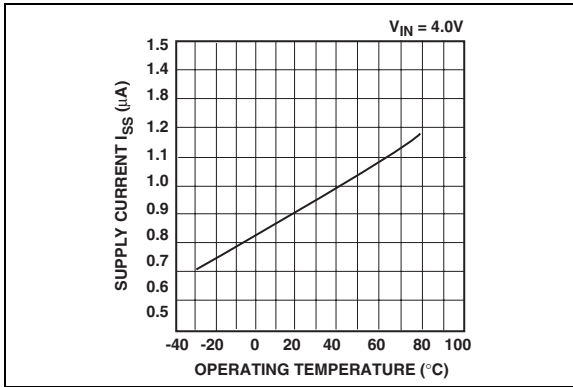


**FIGURE 2-3:** Output Voltage vs. Input Voltage (TC55RP3002).

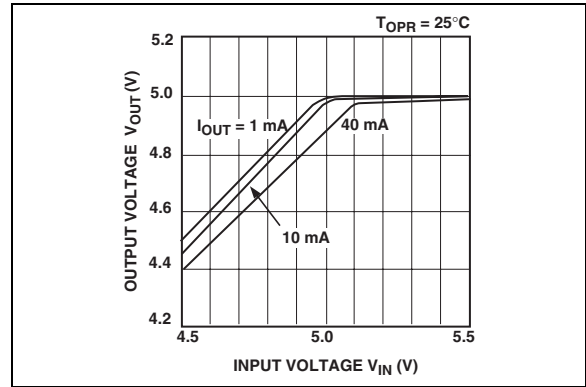


**FIGURE 2-6:** Supply Current vs. Input Voltage (TC55RP3002).

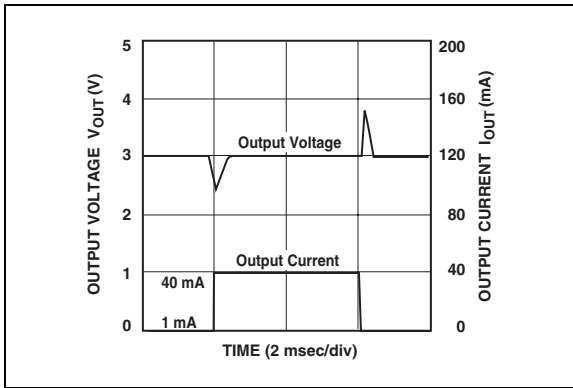
**Note:** Unless otherwise indicated,  $V_{OUT(S)} = 3.0V, 5.0V, T_A = +25^\circ C, C_{IN} = 1 \mu F$  Tantalum,  $C_{OUT} = 1 \mu F$  Tantalum.



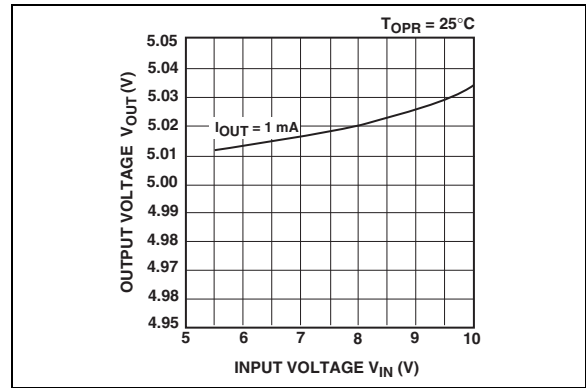
**FIGURE 2-7:** Supply Current vs. Operating Temperature (TC55RP3002).



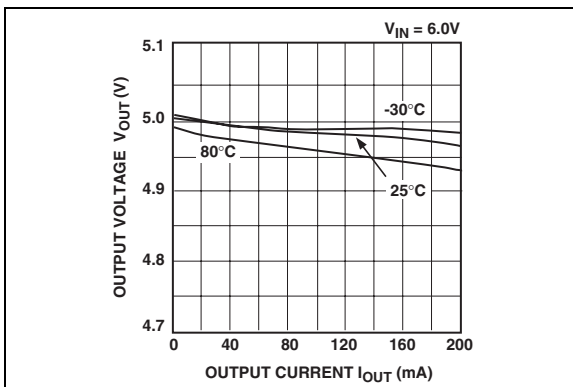
**FIGURE 2-10:** Output Voltage vs. Input Voltage (TC55RP5002).



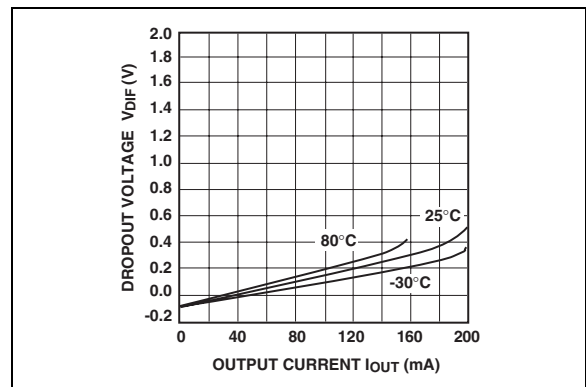
**FIGURE 2-8:** Load Transient Response (TC55RP3002).



**FIGURE 2-11:** Output Voltage vs. Input Voltage (TC55RP5002).



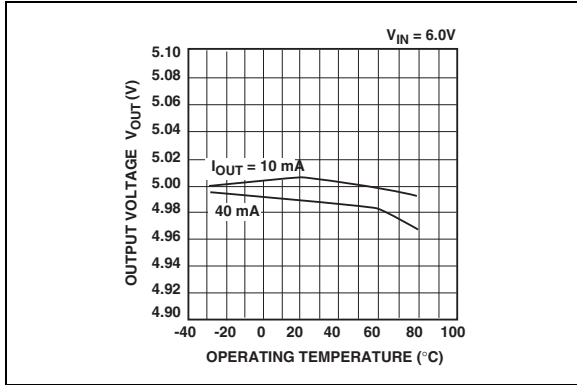
**FIGURE 2-9:** Output Voltage vs. Output Current (TC55RP5002).



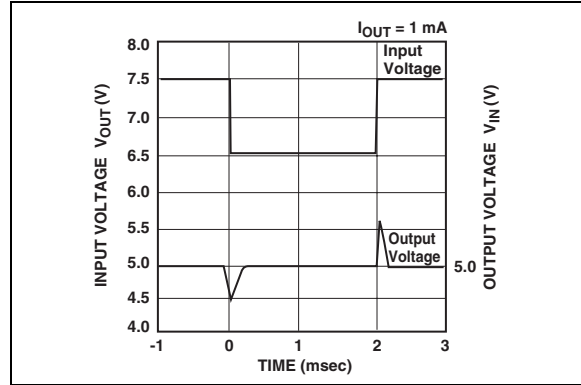
**FIGURE 2-12:** Dropout Voltage vs. Output Current (TC55RP5002).

# TC55

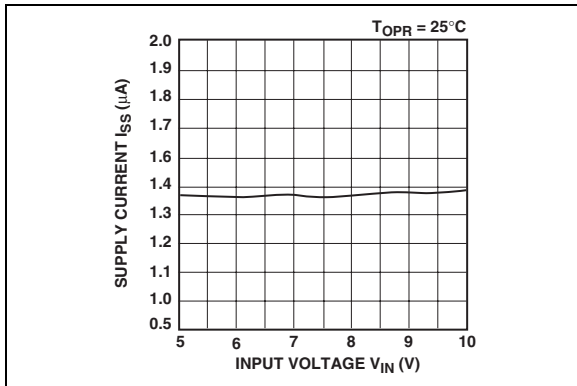
Note: Unless otherwise indicated,  $V_{OUT(S)} = 3.0V, 5.0V$ ,  $T_A = +25^\circ C$ ,  $C_{IN} = 1 \mu F$  Tantalum,  $C_{OUT} = 1 \mu F$  Tantalum.



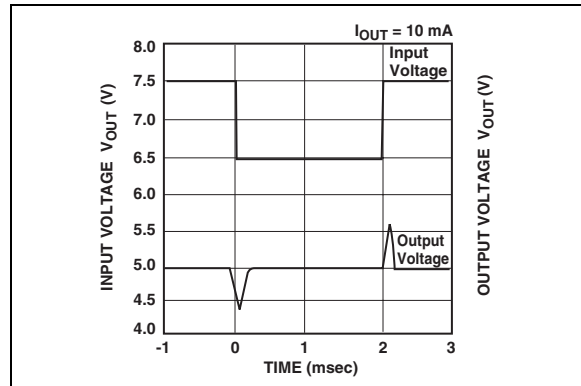
**FIGURE 2-13:** Output Voltage vs. Operating Temperature (TC55RP5002).



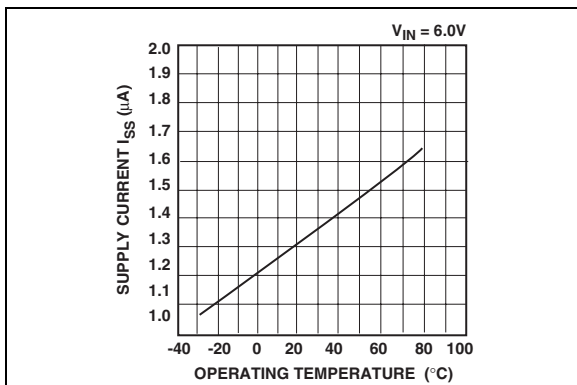
**FIGURE 2-16:** Input Transient Response, 1 mA (TC55RP5002).



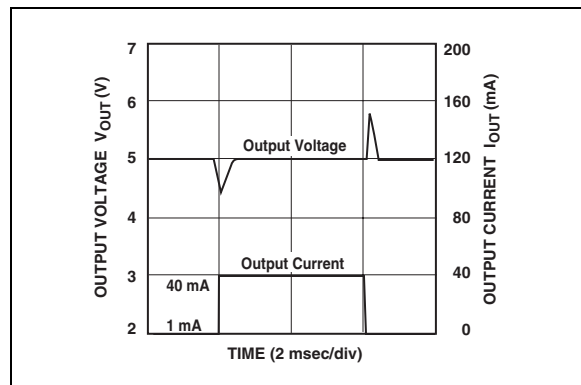
**FIGURE 2-14:** Supply Current vs. Input Voltage (TC55RP5002).



**FIGURE 2-17:** Input Transient Response, 10 mA (TC55RP5002).



**FIGURE 2-15:** Supply Current vs. Operating Temperature (TC55RP5002).



**FIGURE 2-18:** Load Transient Response (TC55RP5002).

## 3.0 PIN DESCRIPTIONS

The descriptions of the pins are listed in Table 3-1.

**TABLE 3-1: PIN FUNCTION TABLE**

Pin No.	Symbol	Description
1	GND	Ground Terminal
2	V <sub>OUT</sub>	Regulated Voltage Output
3	V <sub>IN</sub>	Unregulated Supply Input

### 3.1 Ground Terminal (GND)

Regulator ground. Tie GND to the negative side of the output and the negative side of the input capacitor. Only the LDO bias current (1  $\mu$ A typical) flows out of this pin, there is no high current. The LDO output regulation is referenced to this pin. Minimize voltage drops between this pin and the minus side of the load.

### 3.2 Regulated Voltage Output (V<sub>OUT</sub>)

Connect V<sub>OUT</sub> to the positive side of the load and the positive terminal of the output capacitor. The positive side of the output capacitor should be physically located as close to the LDO V<sub>OUT</sub> pin as is practical. The current flowing out of this pin is equal to the DC load current.

### 3.3 Unregulated Supply Input (V<sub>IN</sub>)

Connect the input supply voltage and the positive side of the input capacitor to V<sub>IN</sub>. The input capacitor should be physically located as close as is practical to V<sub>IN</sub>. The current flow into this pin is equal to the DC load current, plus the LDO bias current (1  $\mu$ A typical.)

## 4.0 DETAILED DESCRIPTION

The TC55 is a low quiescent current, precision, fixed-output voltage LDO. Unlike bipolar regulators, the TC55 supply current does not increase proportionally with load current.

### 4.1 Output Capacitor

A minimum of 1  $\mu$ F output capacitor is required. The output capacitor should have an effective series resistance (esr) greater than 0.1 $\Omega$  and less than 5 $\Omega$ , plus a resonant frequency above 1 MHz. Larger output capacitors can be used to improve supply noise rejection and transient response. Care should be taken when increasing C<sub>OUT</sub> to ensure that the input impedance is not high enough to cause high input impedance oscillation.

### 4.2 Input Capacitor

A 1  $\mu$ F input capacitor is recommended for most applications when the input impedance is on the order of 10 $\Omega$ . Larger input capacitance may be required for stability when operating off of a battery input, or if there is a large distance from the input source to the LDO. When large values of output capacitance are used, the input capacitance should be increased to prevent high source impedance oscillations.

## 5.0 THERMAL CONSIDERATIONS

### 5.1 Power Dissipation

The amount of power dissipated internal to the low dropout linear regulator is the sum of the power dissipation within the linear pass device (P-Channel MOS-FET) and the quiescent current required to bias the internal reference and error amplifier. The internal linear pass device power dissipation is calculated by multiplying the voltage across the linear device by the current through the device.

#### EQUATION

$$P_D (\text{Pass Device}) = (V_{IN} - V_{OUT}) \times I_{OUT}$$

The internal power dissipation, as a result of the bias current for the LDO internal reference and error amplifier, is calculated by multiplying the ground or quiescent current by the input voltage.

#### EQUATION

$$P_D (\text{Bias}) = V_{IN} \times I_{GND}$$

The total internal power dissipation is the sum of  $P_D$  (Pass Device) and  $P_D$  (Bias).

#### EQUATION

$$P_{TOTAL} = P_D (\text{Pass Device}) + P_D (\text{Bias})$$

For the TC55, the internal quiescent bias current is so low (1  $\mu$ A typical) that the  $P_D$  (Bias) term of the power dissipation equation can be ignored. The maximum power dissipation can be estimated by using the maximum input voltage and the minimum output voltage to obtain a maximum voltage differential between input and output. The next step would be to multiply the maximum voltage differential by the maximum output current.

#### EQUATION

$$P_D = (V_{INMAX} - V_{OUTMIN}) \times I_{OUTMAX}$$

Given:

$$V_{IN} = 3.3V \text{ to } 4.1V$$

$$V_{OUT} = 3.0V \pm 2\%$$

$$I_{OUT} = 1 \text{ mA to } 100 \text{ mA}$$

$$T_{AMAX} = 55^\circ\text{C}$$

$$P_{MAX} = (4.1V - (3.0V \times 0.98)) \times 100 \text{ mA}$$

$$P_{MAX} = 116.0 \text{ milliwatts}$$

To determine the junction temperature of the device, the thermal resistance from junction-to-ambient must be known. The 3-pin SOT-23 thermal resistance from junction-to-air ( $R_{\theta JA}$ ) is estimated to be approximately 359°C/W. The SOT-89  $R_{\theta JA}$  is estimated to be approximately 110°C/W when mounted on 1 square inch of copper. The TO-92  $R_{\theta JA}$  is estimated to be 131.9°C/W. The  $R_{\theta JA}$  will vary with physical layout, airflow and other application-specific conditions.

The device junction temperature is determined by calculating the junction temperature rise above ambient, then adding the rise to the ambient temperature.

#### EQUATION

##### Junction Temperature

##### SOT-23 Example:

$$T_J = P_{DMAX} \times R_{\theta JA} + T_A$$

$$T_J = 116.0 \text{ milliwatts} \times 359^\circ\text{C/W} + 55^\circ\text{C}$$

$$T_J = 96.6^\circ\text{C}$$

##### SOT-89 Example:

$$T_J = 116.0 \text{ milliwatts} \times 110^\circ\text{C/W} + 55^\circ\text{C}$$

$$T_J = 67.8^\circ\text{C}$$

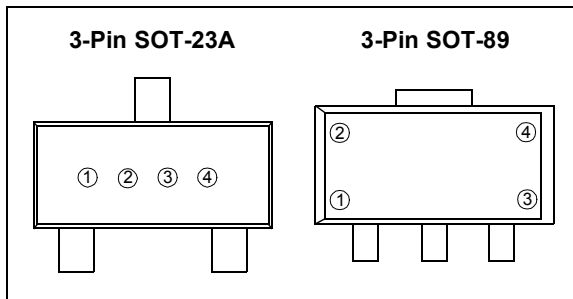
##### TO-92 Example:

$$T_J = 116.0 \text{ milliwatts} \times 131.9^\circ\text{C/W} + 55^\circ\text{C}$$

$$T_J = 70.3^\circ\text{C}$$

## 6.0 PACKAGING INFORMATION

### 6.1 Package Marking Information



① represents first voltage digit  
2V, 3V, 4V, 5V, 6V

Ex: 3.xV = ③ ○ ○ ○

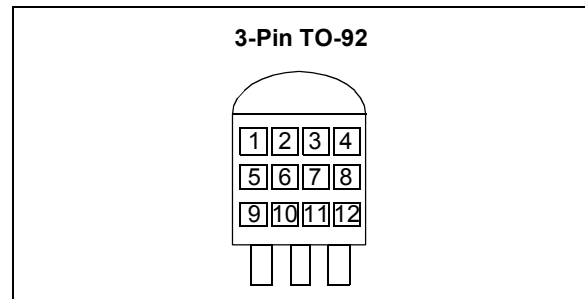
② represents first decimal place voltage (x.0 - x.9)

Ex: 3.4V = ③ ④ ○ ○

Symbol	Voltage	Symbol	Voltage
A	x.0	F	x.5
B	x.1	H	x.6
C	x.2	K	x.7
D	x.3	L	x.8
E	x.4	M	x.9

③ represents polarity  
0 = Positive (fixed)

④ represents assembly lot number



①, ②, ③ & ④ = 55RP (fixed)

⑤ represents first voltage digit (2-6)

⑥ represents first voltage decimal (0-9)

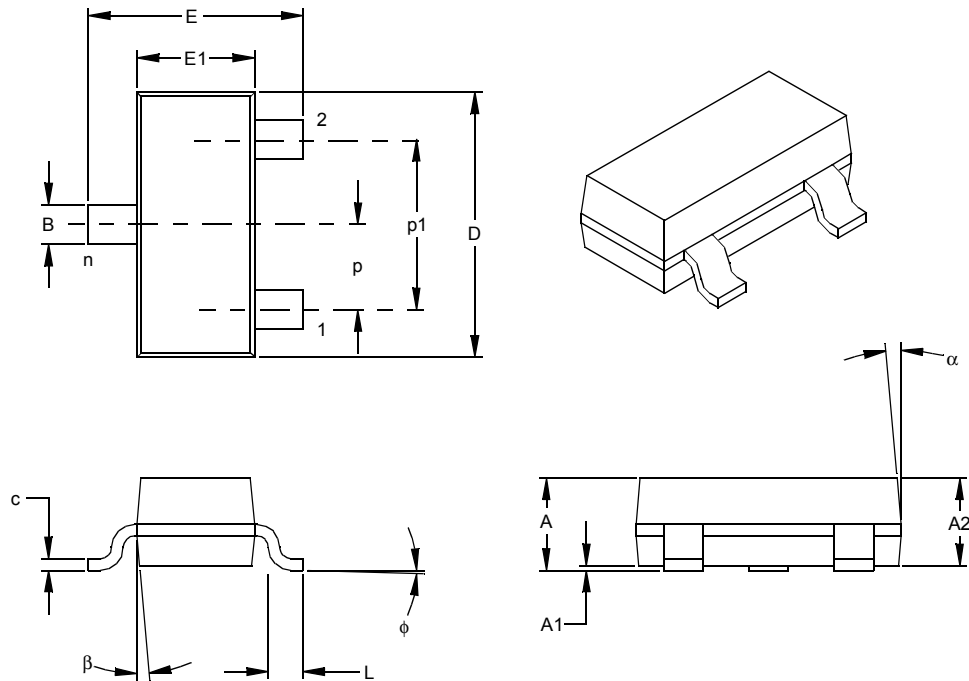
⑦ represents extra feature code: fixed: 0

⑧ represents regulation accuracy  
1 = ±1.0% (custom), 2 = ±2.0% (standard)

⑨, ⑩, ⑪ & ⑫ represents assembly lot number

# TC55

## 3-Lead Plastic Small Outline Transistor (CB) (SOT23)



Units		INCHES*			MILLIMETERS		
Dimension Limits		MIN	NOM	MAX	MIN	NOM	MAX
Number of Pins	n		3			3	
Pitch	p		.038			0.96	
Outside lead pitch (basic)	p1		.076			1.92	
Overall Height	A	.035	.040	.044	0.89	1.01	1.12
Molded Package Thickness	A2	.035	.037	.040	0.88	0.95	1.02
Standoff §	A1	.000	.002	.004	0.01	0.06	0.10
Overall Width	E	.083	.093	.104	2.10	2.37	2.64
Molded Package Width	E1	.047	.051	.055	1.20	1.30	1.40
Overall Length	D	.110	.115	.120	2.80	2.92	3.04
Foot Length	L	.014	.018	.022	0.35	0.45	0.55
Foot Angle	φ	0	5	10	0	5	10
Lead Thickness	c	.004	.006	.007	0.09	0.14	0.18
Lead Width	B	.015	.017	.020	0.37	0.44	0.51
Mold Draft Angle Top	α	0	5	10	0	5	10
Mold Draft Angle Bottom	β	0	5	10	0	5	10

\* Controlling Parameter  
 § Significant Characteristic

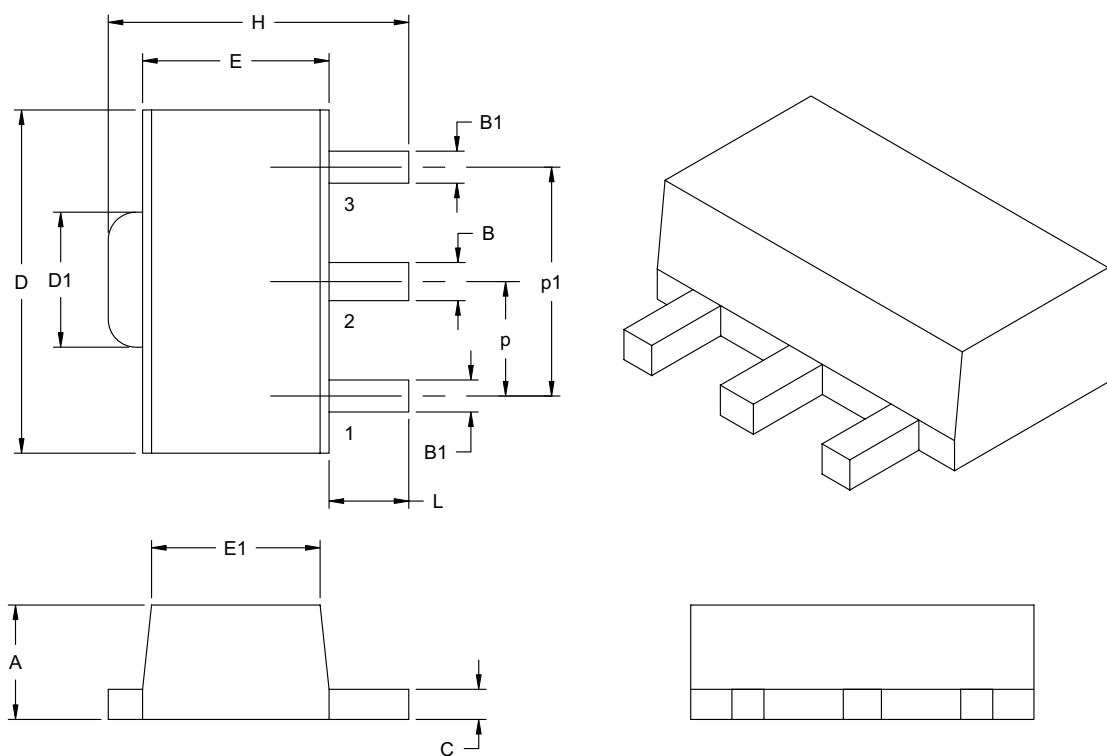
Notes:

Dimensions D and E1 do not include mold flash or protrusions. Mold flash or protrusions shall not exceed .010" (0.254mm) per side.

JEDEC Equivalent: TO-236

Drawing No. C04-104

## 3-Lead Plastic Small Outline Transistor (MB) (SOT89)



Dimension Limits	Units	INCHES		MILLIMETERS*	
		MIN	MAX	MIN	MAX
Pitch	P	.059 BSC		1.50 BSC	
Outside lead pitch (basic)	p1	.118 BSC		3.00 BSC	
Overall Height	A	.055	.063	1.40	1.60
Overall Width	H	.155	.167	3.94	4.25
Molded Package Width at Base	E	.090	.102	2.29	2.60
Molded Package Width at Top	E1	.084	.090	2.13	2.29
Overall Length	D	.173	.181	4.40	4.60
Tab Length	D1	.064	.072	1.62	1.83
Foot Length	L	.035	.047	0.89	1.20
Lead Thickness	c	.014	.017	0.35	0.44
Lead 2 Width	B	.017	.022	0.44	0.56
Leads 1 & 3 Width	B1	.014	.019	0.36	0.48

\*Controlling Parameter

Notes:

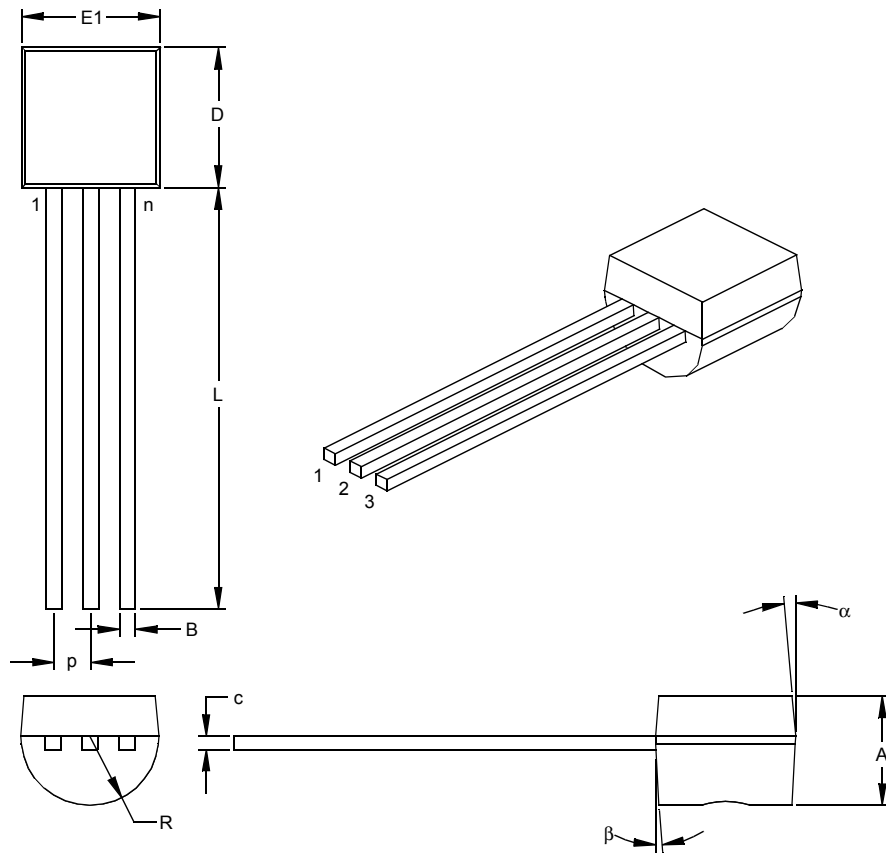
Dimensions D and E1 do not include mold flash or protrusions. Mold flash or protrusions shall not exceed .005" (0.127mm) per side.

JEDEC Equivalent: TO-243

Drawing No. C04-29

# TC55

## 3-Lead Plastic Transistor Outline (ZB) (TO-92)



Dimension Limits	Units	INCHES*			MILLIMETERS		
		MIN	NOM	MAX	MIN	NOM	MAX
Number of Pins	n		3			3	
Pitch	p		.050			1.27	
Bottom to Package Flat	A	.130	.143	.155	3.30	3.62	3.94
Overall Width	E1	.175	.186	.195	4.45	4.71	4.95
Overall Length	D	.170	.183	.195	4.32	4.64	4.95
Molded Package Radius	R	.085	.090	.095	2.16	2.29	2.41
Tip to Seating Plane	L	.500	.555	.610	12.70	14.10	15.49
Lead Thickness	c	.014	.017	.020	0.36	0.43	0.51
Lead Width	B	.016	.019	.022	0.41	0.48	0.56
Mold Draft Angle Top	$\alpha$	4	5	6	4	5	6
Mold Draft Angle Bottom	$\beta$	2	3	4	2	3	4

\*Controlling Parameter

Notes:

Dimensions D and E1 do not include mold flash or protrusions. Mold flash or protrusions shall not exceed .010" (0.254mm) per side.

JEDEC Equivalent: TO-92

Drawing No. C04-101

## PRODUCT IDENTIFICATION SYSTEM

To order or obtain information, e.g., on pricing or delivery, refer to the factory or the listed sales office.

<u>PART NO.</u>	<u>XX</u>	<u>X</u>	<u>X</u>	<u>X</u>	<u>XX</u>	<u>XX</u>
Device	Output Voltage	Feature Code	Tolerance	Temp.	Package	Taping Direction
Device:	TC55: 1 $\mu$ A Low Dropout Positive Voltage Regulator					
Output Voltage:	12 = 1.2V "Standard" 18 = 1.8V "Standard" 25 = 2.5V "Standard" 30 = 3.0V "Standard" 33 = 3.3V "Standard" 50 = 5.0V "Standard"					
Extra Feature Code:	0 = Fixed					
Tolerance:	1 = 1.0% (Custom) 2 = 2.0% (Standard)					
Temperature:	E = -40°C to +85°C					
Package Type:	CB = 3-Pin SOT-23A (equivalent to EIAJ SC-59) MB = 3-Pin SOT-89 ZB = 3-Pin TO-92					
Taping Direction:	TR = Standard 713 = Standard					

<b>Examples:</b>	
a)	TC55RP1802ECB713: 1.8V LDO Positive Voltage Regulator, 2% Tolerance SOT23-A-3 package.
b)	TC55RP2502EMB713: 1.8V LDO Positive Voltage Regulator, 2% Tolerance. SOT89-3 package.
c)	TC55RP2502ECB713: 2.5V LDO Positive Voltage Regulator, 2% Tolerance. SOT23-A-3 package.
d)	TC55RP3002ECB713: 3.0V LDO Positive Voltage Regulator, 2% Tolerance. SOT23-A-3 package.
e)	TC55RP3002EMB713: 3.0V LDO Positive Voltage Regulator, 2% Tolerance. SOT89-3 package.
f)	TC55RP3302ECB713: 3.3V LDO Positive Voltage Regulator, 2% Tolerance. SOT23-A-3 package.
g)	TC55RP3302EMB713: 3.3V LDO Positive Voltage Regulator, 2% Tolerance. SOT89-3 package.
h)	TC55RP5002ECB713: 5.0V LDO Positive Voltage Regulator, 2% Tolerance. SOT23-A-3 package.
i)	TC55RP5002EMB713: 5.0V LDO Positive Voltage Regulator, 2% Tolerance. SOT89-3 package.

## Sales and Support

### Data Sheets

Products supported by a preliminary Data Sheet may have an errata sheet describing minor operational differences and recommended workarounds. To determine if an errata sheet exists for a particular device, please contact one of the following:

1. Your local Microchip sales office
2. The Microchip Corporate Literature Center U.S. FAX: (480) 792-7277
3. The Microchip Worldwide Site ([www.microchip.com](http://www.microchip.com))

Please specify which device, revision of silicon and Data Sheet (include Literature #) you are using.

### Customer Notification System

Register on our web site ([www.microchip.com/cn](http://www.microchip.com/cn)) to receive the most current information on our products.

# TC55

---

NOTES:

---

---

**Note the following details of the code protection feature on Microchip devices:**

- Microchip products meet the specification contained in their particular Microchip Data Sheet.
- Microchip believes that its family of products is one of the most secure families of its kind on the market today, when used in the intended manner and under normal conditions.
- There are dishonest and possibly illegal methods used to breach the code protection feature. All of these methods, to our knowledge, require using the Microchip products in a manner outside the operating specifications contained in Microchip's Data Sheets. Most likely, the person doing so is engaged in theft of intellectual property.
- Microchip is willing to work with the customer who is concerned about the integrity of their code.
- Neither Microchip nor any other semiconductor manufacturer can guarantee the security of their code. Code protection does not mean that we are guaranteeing the product as "unbreakable."

Code protection is constantly evolving. We at Microchip are committed to continuously improving the code protection features of our products. Attempts to break microchip's code protection feature may be a violation of the Digital Millennium Copyright Act. If such acts allow unauthorized access to your software or other copyrighted work, you may have a right to sue for relief under that Act.

---

Information contained in this publication regarding device applications and the like is intended through suggestion only and may be superseded by updates. It is your responsibility to ensure that your application meets with your specifications. No representation or warranty is given and no liability is assumed by Microchip Technology Incorporated with respect to the accuracy or use of such information, or infringement of patents or other intellectual property rights arising from such use or otherwise. Use of Microchip's products as critical components in life support systems is not authorized except with express written approval by Microchip. No licenses are conveyed, implicitly or otherwise, under any intellectual property rights.

#### Trademarks

The Microchip name and logo, the Microchip logo, KEELOQ, MPLAB, PIC, PICmicro, PICSTART, PRO MATE and PowerSmart are registered trademarks of Microchip Technology Incorporated in the U.S.A. and other countries.


FilterLab, microID, MXDEV, MXLAB, PICMASTER, SEEVAL and The Embedded Control Solutions Company are registered trademarks of Microchip Technology Incorporated in the U.S.A.

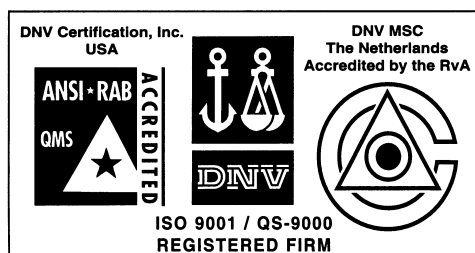
Accuron, Application Maestro, dsPIC, dsPICDEM, dsPICDEM.net, ECONOMONITOR, FanSense, FlexROM, fuzzyLAB, In-Circuit Serial Programming, ICSP, ICEPIC, microPort, Migratable Memory, MPASM, MPLIB, MPLINK, MPSIM, PICC, PICkit, PICDEM, PICDEM.net, PowerCal, PowerInfo, PowerMate, PowerTool, rLAB, rPIC, Select Mode, SmartSensor, SmartShunt, SmartTel and Total Endurance are trademarks of Microchip Technology Incorporated in the U.S.A. and other countries.

Serialized Quick Turn Programming (SQTP) is a service mark of Microchip Technology Incorporated in the U.S.A.

All other trademarks mentioned herein are property of their respective companies.

© 2003, Microchip Technology Incorporated, Printed in the U.S.A., All Rights Reserved.

 Printed on recycled paper.



*Microchip received QS-9000 quality system certification for its worldwide headquarters, design and wafer fabrication facilities in Chandler and Tempe, Arizona in July 1999 and Mountain View, California in March 2002. The Company's quality system processes and procedures are QS-9000 compliant for its PICmicro® 8-bit MCUs, KEELOQ® code hopping devices, Serial EEPROMs, microperipherals, non-volatile memory and analog products. In addition, Microchip's quality system for the design and manufacture of development systems is ISO 9001 certified.*



## WORLDWIDE SALES AND SERVICE

### AMERICAS

#### Corporate Office

2355 West Chandler Blvd.  
Chandler, AZ 85224-6199  
Tel: 480-792-7200 Fax: 480-792-7277  
Technical Support: 480-792-7627  
Web Address: <http://www.microchip.com>

#### Atlanta

3780 Mansell Road, Suite 130  
Alpharetta, GA 30022  
Tel: 770-640-0034 Fax: 770-640-0307

#### Boston

2 Lan Drive, Suite 120  
Westford, MA 01886  
Tel: 978-692-3848 Fax: 978-692-3821

#### Chicago

333 Pierce Road, Suite 180  
Itasca, IL 60143  
Tel: 630-285-0071 Fax: 630-285-0075

#### Dallas

4570 Westgrove Drive, Suite 160  
Addison, TX 75001  
Tel: 972-818-7423 Fax: 972-818-2924

#### Detroit

Tri-Atria Office Building  
32255 Northwestern Highway, Suite 190  
Farmington Hills, MI 48334  
Tel: 248-538-2250 Fax: 248-538-2260

#### Kokomo

2767 S. Albright Road  
Kokomo, IN 46902  
Tel: 765-864-8360 Fax: 765-864-8387

#### Los Angeles

18201 Von Karman, Suite 1090  
Irvine, CA 92612  
Tel: 949-263-1888 Fax: 949-263-1338

#### Phoenix

2355 West Chandler Blvd.  
Chandler, AZ 85224-6199  
Tel: 480-792-7966 Fax: 480-792-4338

#### San Jose

Microchip Technology Inc.  
2107 North First Street, Suite 590  
San Jose, CA 95131  
Tel: 408-436-7950 Fax: 408-436-7955

#### Toronto

6285 Northam Drive, Suite 108  
Mississauga, Ontario L4V 1X5, Canada  
Tel: 905-673-0699 Fax: 905-673-6509

### ASIA/PACIFIC

#### Australia

Microchip Technology Australia Pty Ltd  
Marketing Support Division  
Suite 22, 41 Rawson Street  
Epping 2121, NSW  
Australia  
Tel: 61-2-9868-6733 Fax: 61-2-9868-6755

#### China - Beijing

Microchip Technology Consulting (Shanghai)  
Co., Ltd., Beijing Liaison Office  
Unit 915  
Bei Hai Wan Tai Bldg.  
No. 6 Chaoyangmen Beidajie  
Beijing, 100027, No. China  
Tel: 86-10-85282100 Fax: 86-10-85282104

#### China - Chengdu

Microchip Technology Consulting (Shanghai)  
Co., Ltd., Chengdu Liaison Office  
Rm. 2401-2402, 24th Floor,  
Ming Xing Financial Tower  
No. 88 TIDU Street  
Chengdu 610016, China  
Tel: 86-28-86766200 Fax: 86-28-86766599

#### China - Fuzhou

Microchip Technology Consulting (Shanghai)  
Co., Ltd., Fuzhou Liaison Office  
Unit 28F, World Trade Plaza  
No. 71 Wusi Road  
Fuzhou 350001, China  
Tel: 86-591-7503506 Fax: 86-591-7503521

#### China - Hong Kong SAR

Microchip Technology Hongkong Ltd.  
Unit 901-6, Tower 2, Metroplaza  
223 Hing Fong Road  
Kwai Fong, N.T., Hong Kong  
Tel: 852-2401-1200 Fax: 852-2401-3431

#### China - Shanghai

Microchip Technology Consulting (Shanghai)  
Co., Ltd.  
Room 701, Bldg. B  
Far East International Plaza  
No. 317 Xian Xia Road  
Shanghai, 200051  
Tel: 86-21-6275-5700 Fax: 86-21-6275-5060

#### China - Shenzhen

Microchip Technology Consulting (Shanghai)  
Co., Ltd., Shenzhen Liaison Office  
Rm. 1812, 18/F, Building A, United Plaza  
No. 5022 Binhe Road, Futian District  
Shenzhen 518033, China  
Tel: 86-755-82901380 Fax: 86-755-8295-1393

#### China - Qingdao

Rm. B505A, Fullhope Plaza,  
No. 12 Hong Kong Central Rd.  
Qingdao 266071, China  
Tel: 86-532-5027355 Fax: 86-532-5027205

#### India

Microchip Technology Inc.  
India Liaison Office  
Marketing Support Division  
Divyasree Chambers  
1 Floor, Wing A (A3/A4)  
No. 11, O'Shaughnessey Road  
Bangalore, 560 025, India  
Tel: 91-80-2290061 Fax: 91-80-2290062

### Japan

Microchip Technology Japan K.K.  
Benex S-1 6F  
3-18-20, Shinyokohama  
Kohoku-Ku, Yokohama-shi  
Kanagawa, 222-0033, Japan  
Tel: 81-45-471-6166 Fax: 81-45-471-6122

### Korea

Microchip Technology Korea  
168-1, Youngbo Bldg. 3 Floor  
Samsung-Dong, Kangnam-Ku  
Seoul, Korea 135-882  
Tel: 82-2-554-7200 Fax: 82-2-558-5934

### Singapore

Microchip Technology Singapore Pte Ltd.  
200 Middle Road  
#07-02 Prime Centre  
Singapore, 188980  
Tel: 65-6334-8870 Fax: 65-6334-8850

### Taiwan

Microchip Technology (Barbados) Inc.,  
Taiwan Branch  
11F-3, No. 207  
Tung Hua North Road  
Taipei, 105, Taiwan  
Tel: 886-2-2717-7175 Fax: 886-2-2545-0139

### EUROPE

#### Austria

Microchip Technology Austria GmbH  
Durisolstrasse 2  
A-4600 Wels  
Austria  
Tel: 43-7242-2244-399  
Fax: 43-7242-2244-393

#### Denmark

Microchip Technology Nordic ApS  
Regus Business Centre  
Lautrup høj 1-3  
Ballerup DK-2750 Denmark  
Tel: 45-4420-9895 Fax: 45-4420-9910

#### France

Microchip Technology SARL  
Parc d'Activite du Moulin de Massy  
43 Rue du Saule Trapu  
Batiment A - ler Etage  
91300 Massy, France  
Tel: 33-1-69-53-63-20 Fax: 33-1-69-30-90-79

#### Germany

Microchip Technology GmbH  
Steinheilstrasse 10  
D-85737 Ismaning, Germany  
Tel: 49-89-627-144-0  
Fax: 49-89-627-144-44

#### Italy

Microchip Technology SRL  
Via Quasimodo, 12  
20025 Legnano (MI)  
Milan, Italy  
Tel: 39-0331-742611 Fax: 39-0331-466781

#### United Kingdom

Microchip Ltd.  
505 Eskdale Road  
Winnersh Triangle  
Wokingham  
Berkshire, England RG41 5TU  
Tel: 44-118-921-5869 Fax: 44-118-921-5820

05/30/03