

ULTRA HIGH SPEED SWITCHING APPLICATION.

FEATURES

- Small Package : ESM.
- Low Forward Voltage : $V_F=0.92V$ (Typ.).
- Fast Reverse Recovery Time : $t_{rr}=1.6ns$ (Typ.).
- Small Total Capacitance : $C_T=2.2pF$ (Typ.).

MAXIMUM RATING (Ta=25°C)

CHARACTERISTIC	SYMBOL	RATING	UNIT
Maximum (Peak) Reverse Voltage	V_{RM}	85	V
Reverse Voltage	V_R	80	V
Maximum (Peak) Forward Current	I_{FM}	300 *	mA
Average Forward Current	I_O	100 *	mA
Surge Current (10ms)	I_{FSM}	2 *	A
Power Dissipation	P_D	100	mW
Junction Temperature	T_j	150	°C
Storage Temperature Range	T_{stg}	-55 ~ 150	°C

Note : * Unit Rating. Total Rating=Unit Rating x 1.5

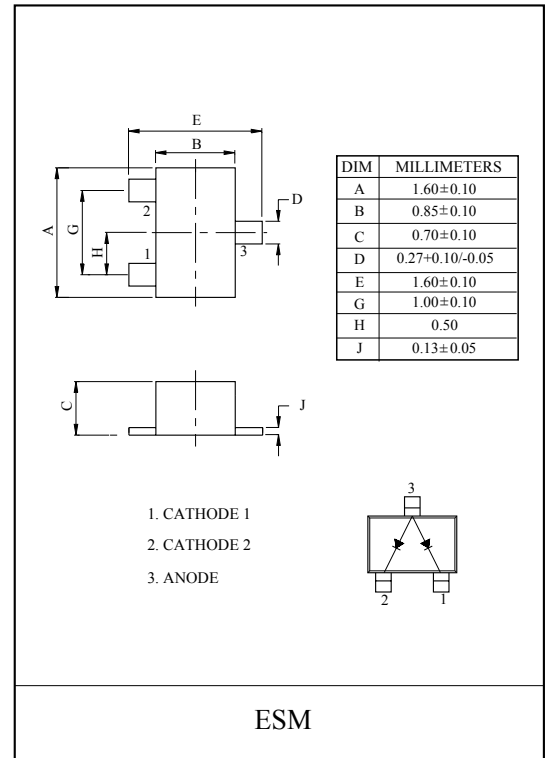

Marking

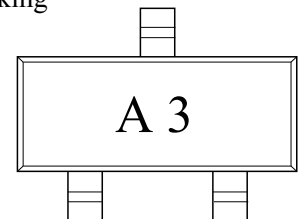

ELECTRICAL CHARACTERISTICS (Ta=25°C)

CHARACTERISTIC	SYMBOL	TEST CONDITION	MIN.	TYP.	MAX.	UNIT
Forward Voltage	$V_{F(1)}$	$I_F=1mA$	-	0.61	-	V
	$V_{F(2)}$	$I_F=10mA$	-	0.74	-	
	$V_{F(3)}$	$I_F=100mA$	-	0.92	1.20	
Reverse Current	I_R	$V_R=80V$	-	-	0.5	μA
Total Capacitance	C_T	$V_R=0, f=1MHz$	-	2.2	4.0	pF
Reverse Recovery Time	t_{rr}	$I_F=10mA$	-	1.6	4.0	nS