

DUAL OPERATIONAL AMPLIFIER

- In the Linear Mode the Input Common Mode Voltage Range Includes Ground.
- Two Internally Compensated OP Amps are in Single Package.
- Low Power Dissipation and Power Drain Suitable for Battery Operation.
- Differential Input Voltage Range Equal to the Power Supply Voltage.
- Wide Power Supply Voltage Range and Signal Power Supply
: Single Supply $3V_{DC}$ to $36V_{DC}$ Dual Supplies $\pm 1.5V_{DC}$ to $\pm 18V_{DC}$
- Large Output Voltage Swing : $0V_{DC}$ to $V_{CC}-1.5V_{DC}$
- Low Input Biasing Current : $I_I=45nA_{DC}$ (Typ.)
- Possible to Exchange the Position of Pin ⑨ for Pin ① Because of Pin Connection Being Symmetric. (KIA358S only)
- The Pin ① and Pin ⑨ of Lead Frame was Each Other Connected. (KIA358S Only)

PIN CONNECTION (TOP VIEW)

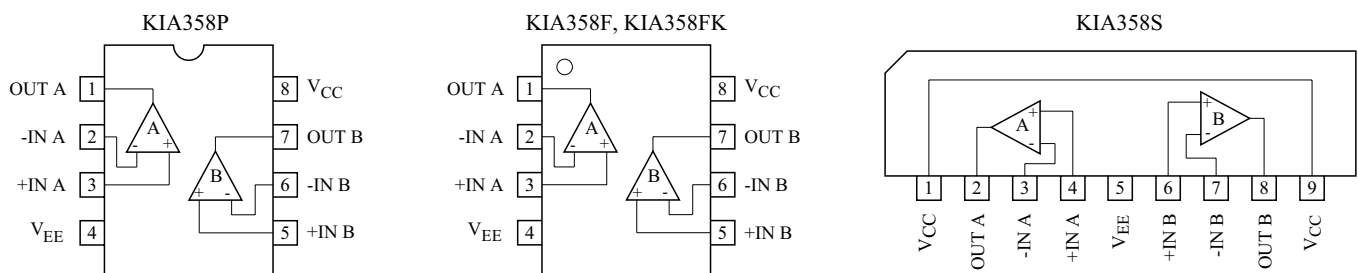

MARKING

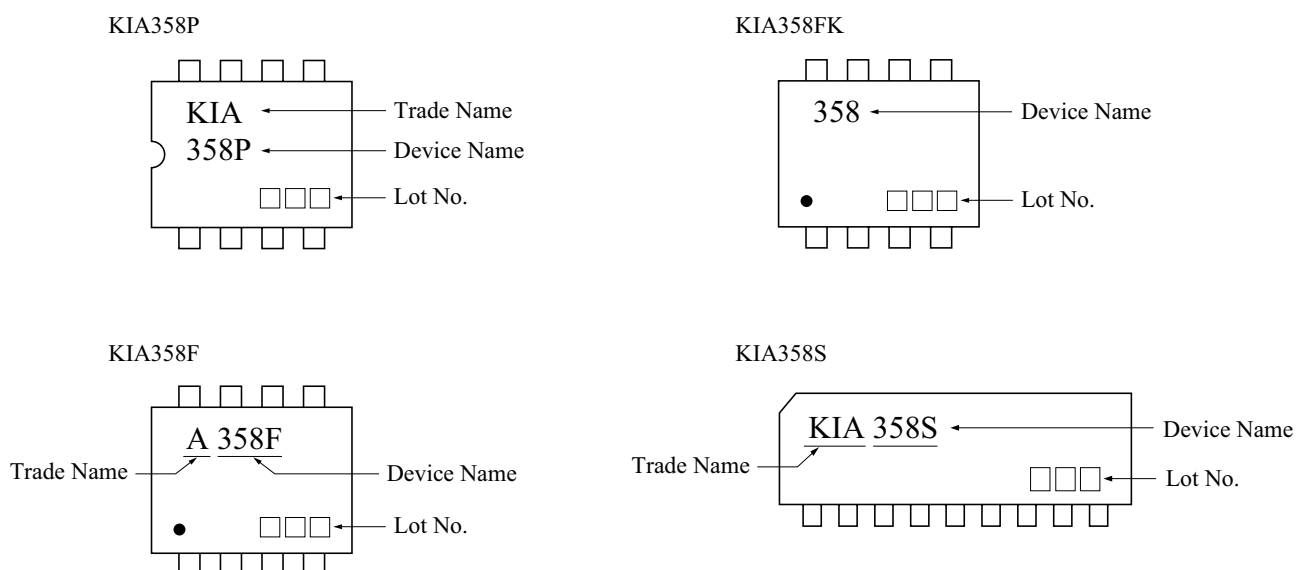

KIA358P/S/F/FK

EQUIVALENT CIRCUIT

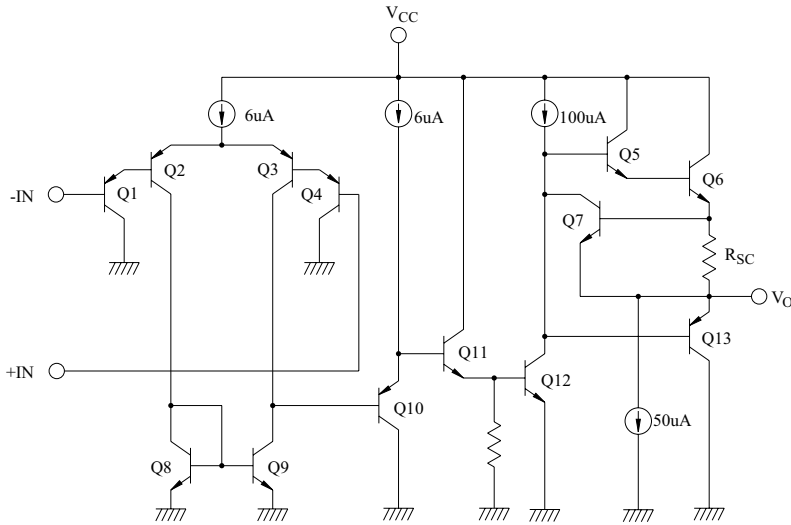

MAXIMUM RATINGS (Ta=25 °C)

CHARACTERISTIC		SYMBOL	RATING	UNIT
Supply Voltage		V_{CC}	36, +18	V
		V_{EE}	0, -18	
Differential Input Voltage		DV_{IN}	± 36	V
Input Voltage		V_{IN}	-0.3 ~ 36	V
Power Dissipation	KIA358P/S	P_D	500	mW
	KIA358F		280	
	KIA358FK		200	
Operating Temperature		T_{opr}	-40 ~ 85	°C
Storage Temperature		T_{stg}	-55 ~ 125	°C
Pin ① to Pin ⑨ Maximum Current	KIA358S	I_{max}	1	A

ELECTRICAL CHARACTERISTICS (V_{CC}=5V, V_{EE}=GND, Ta=25 °C)

CHARACTERISTIC	SYMBOL	TEST CONDITION	MIN.	TYP.	MAX.	UNIT
Input Offset Voltage	V_{IO}	$R_g \leq 10k \Omega$	-	2	7	mV
Input Offset Current	I_{IO}	-	-	5	30	nA
Input Bias Current	I_I	-	-	45	150	nA
Common Mode Input Voltage	CMV_{IN}	$V_{CC}=30V, V_{EE}=GND$	0	-	$V_{CC}-1.5$	V
Supply Current	I_{CC}, I_{EE}	$R_L = \infty, \text{ All OP Amps}$	-	0.7	1.2	mA
Voltage Gain	G_V	$R_L \geq 2k \Omega$	86	100	-	dB
Maximum Output Voltage Swing	V_{OP-P}	$R_L = 2k \Omega$	0	$V_{CC}-1.5$	-	V
Common Mode Input Signal Rejection Ratio	CMRR	-	60	85	-	dB
Supply Voltage Rejection Ratio	SVRR	$R_g = 10k \Omega$	60	100	-	dB
Source Current	I_{source}	-IN=0V _{DC} , +IN=1V _{DC}	20	40	-	mA
Sink Current	I_{sink}	-IN=1V _{DC} , +IN=0V _{DC}	10	20	-	mA

KIA358P/S/F/FK

$V_{CC} - I_{CC}$

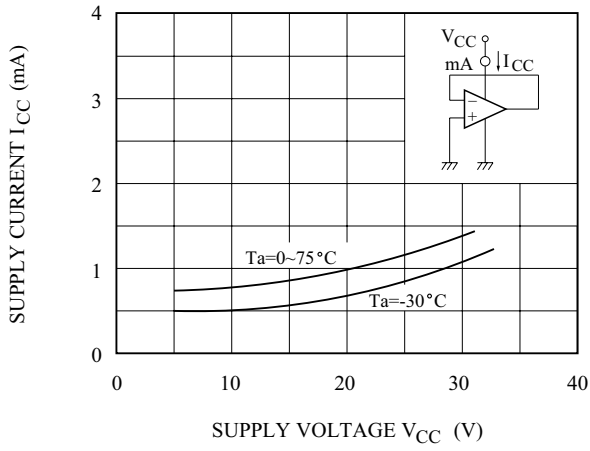

$V_{CC} - I_I$

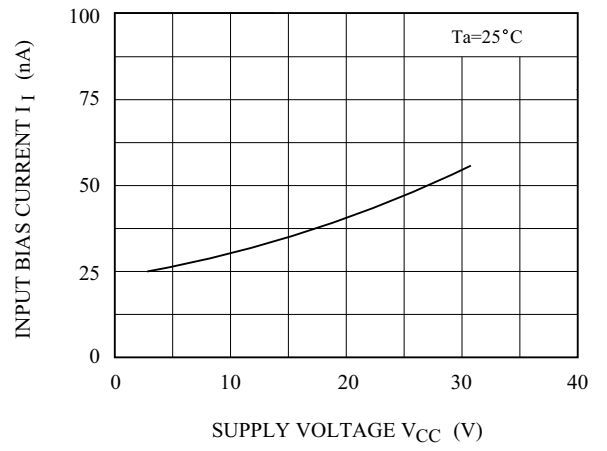

$V_{CC} - G_V$

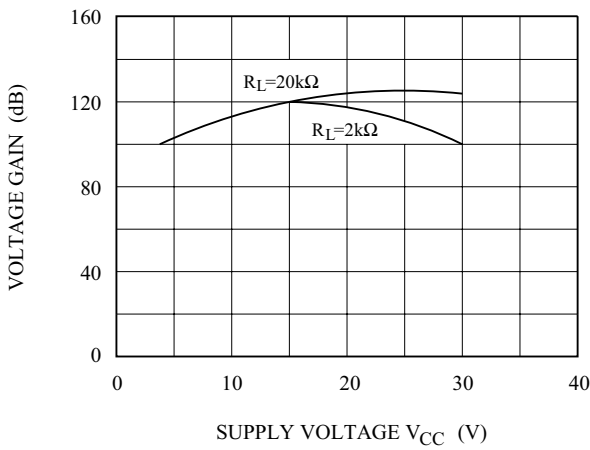

$I_{SOURCE} - T_a$

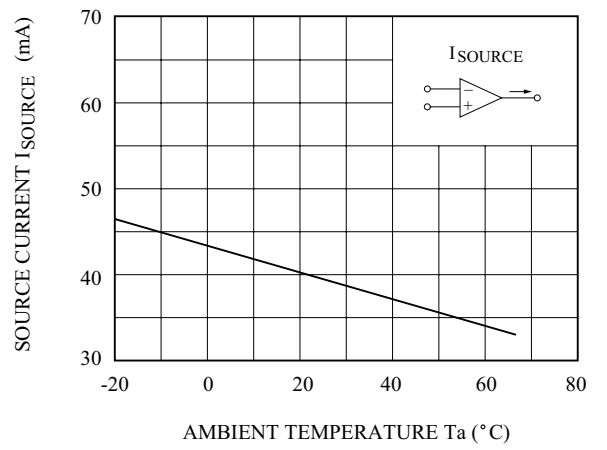

CMRR - f

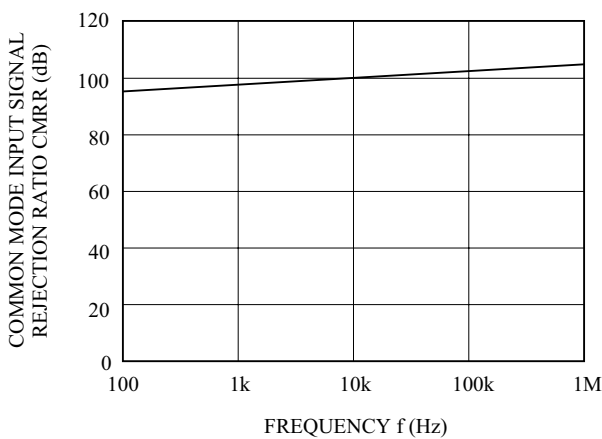

$G_V - f$

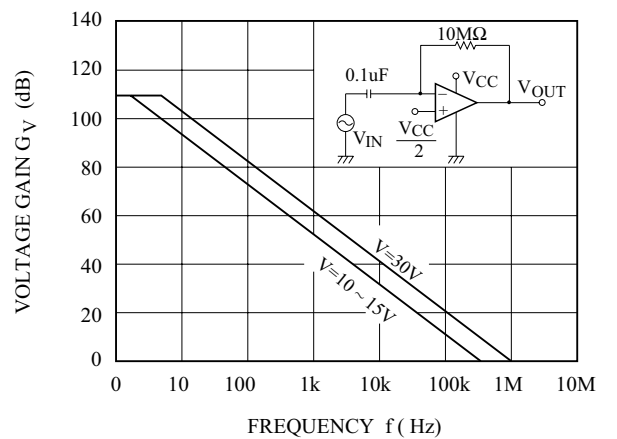

KIA358P/S/F/FK

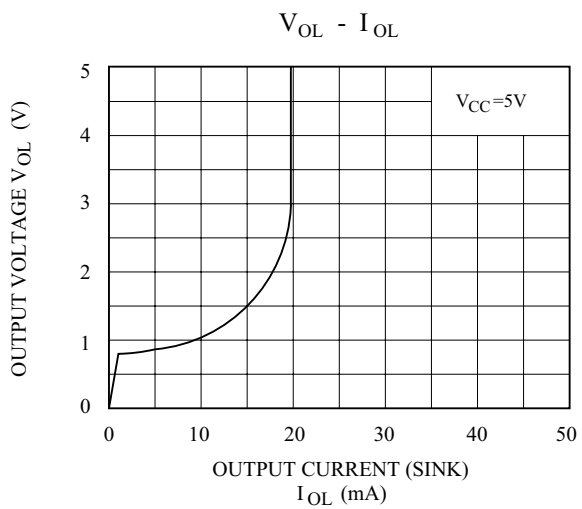
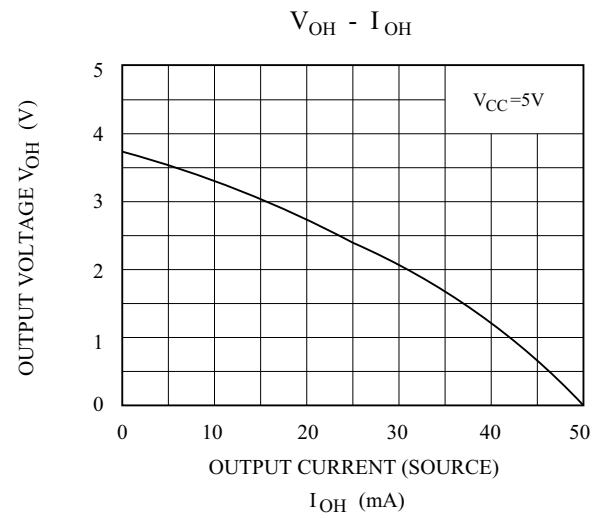
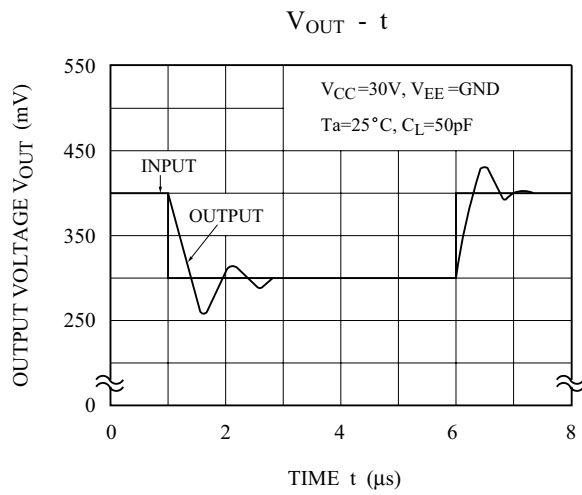
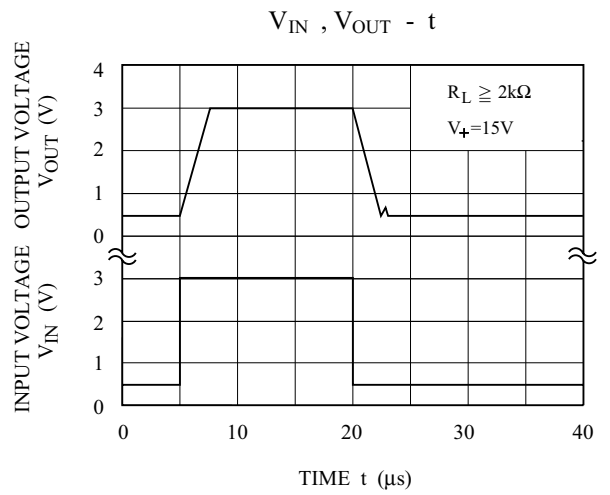
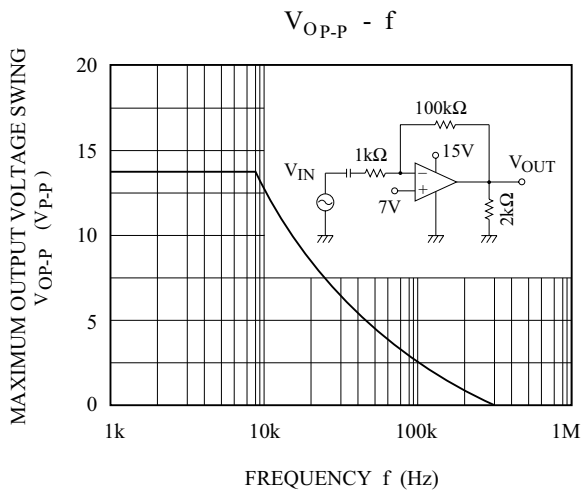

KIA358P/S/F/FK

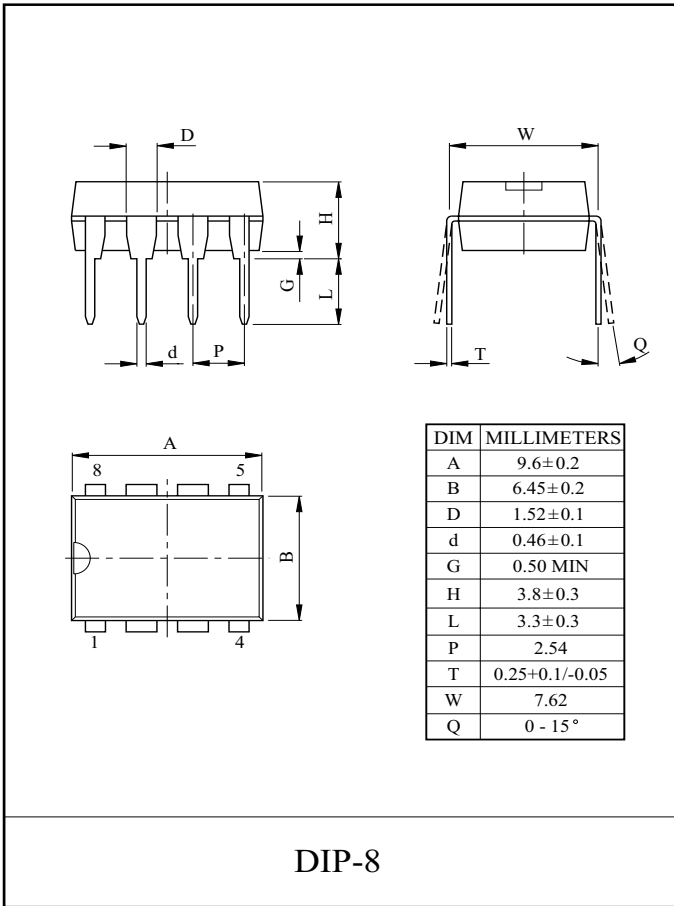

DIP-8

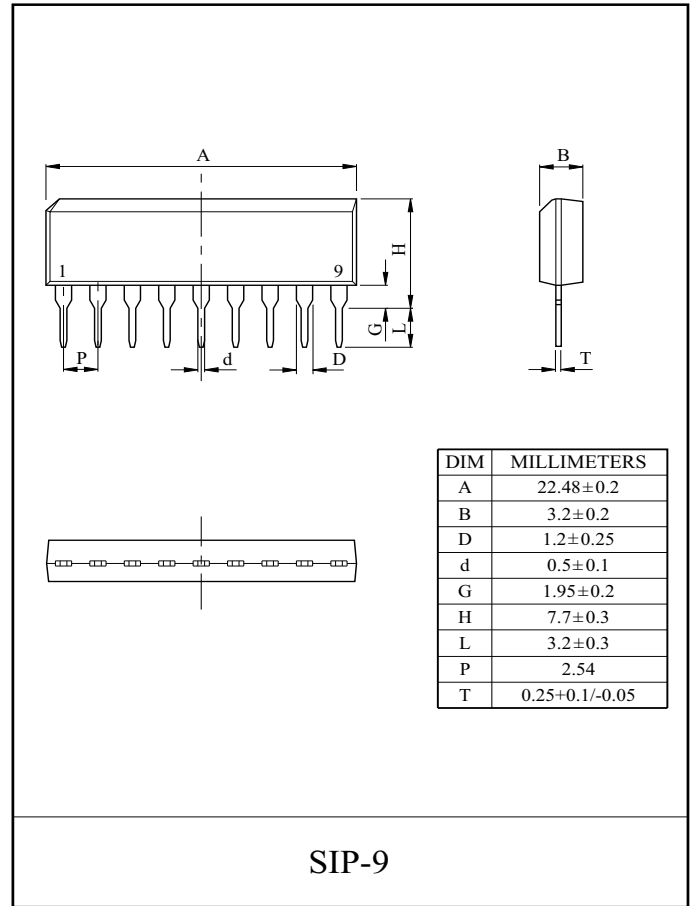

SIP-9

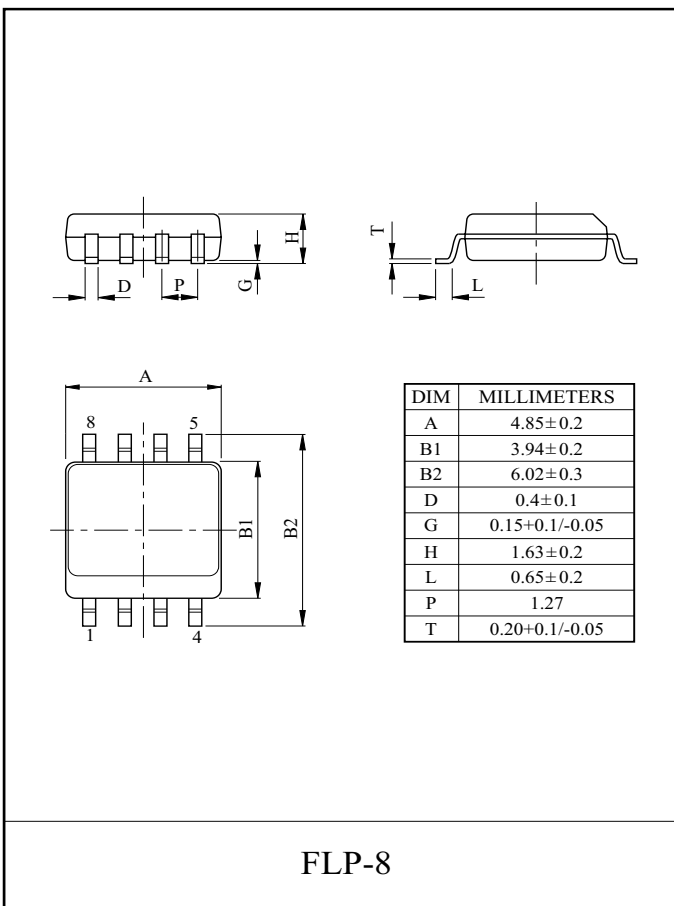

FLP-8

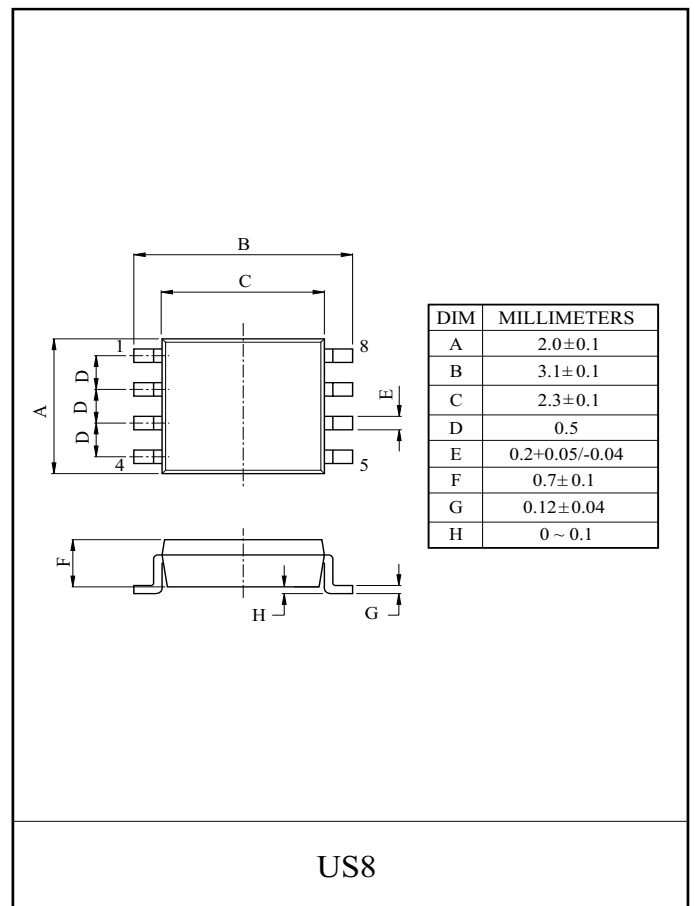

US8