

Voltage-Mode PWM Controller IC

The KIA494AP/AF incorporates on a single monolithic chip all the functions required in the construction of a pulse-width-modulation control circuit. Designed primarily for power supply control, this device offers the systems engineer the flexibility to tailor the power supply control circuitry to a specific application.

The KIA494AP/AF contains two error amplifiers, an on-chip adjustable oscillator, a dead-time control(DTC) comparator, a pulse-steering control flip-flop, a 5-V, 5%-precision regulator, and output-control circuits.

The error amplifiers exhibit a common-mode voltage range from $-0.3V$ to $V_{CC} - 2V$. The dead-time control comparator has a fixed offset that provides approximately 5% dead time. The on-chip oscillator may be bypassed by terminating RT to the reference output and providing a sawtooth input to CT, or it may drive the common circuits in synchronous multiple-rail power supplies.

The uncommitted output transistors provide either common-emitter or emitter-follower output capability. The KIA494AP/AF provides for push-pull or single-ended output operation, which may be selected through the output-control function.

The architecture of this device prohibits the possibility of either output being pulsed twice during push-pull operation.

FEATURES

- Completed PWM Power Control Circuitry.
- Uncommitted Outputs for 200mA Sink or Source Current.
- Output Control Selects Single-Ended or Push-Pull Operation.
- Internal Circuitry Prohibits Double Pulse at Either Output.
- Variable Dead Time Provides Control Over Total Range.
- Internal Regulator Provides a Stable 5V Reference Supply With 5% Tolerance.
- Circuit Architecture Allows Easy Synchronization.

MAXIMUM RATINGS ($T_a=25^\circ C$)

ITEM	SYMBOL	RATING	UNIT
Supply Voltage	V_{CC}	41	V
Error Amplifier Input Voltage	V_{IN}	$V_{CC}+0.3$	V
Collector Output Voltage	V_O	41	V
Collector Output Current	I_O	250	mA
Power Consumption	KIA494AP	750	mW
	KIA494AF	400	
Operating Temperature	T_{opr}	$-40 \sim 85$	$^\circ C$
Storage Temperature	T_{stg}	$-65 \sim 150$	$^\circ C$

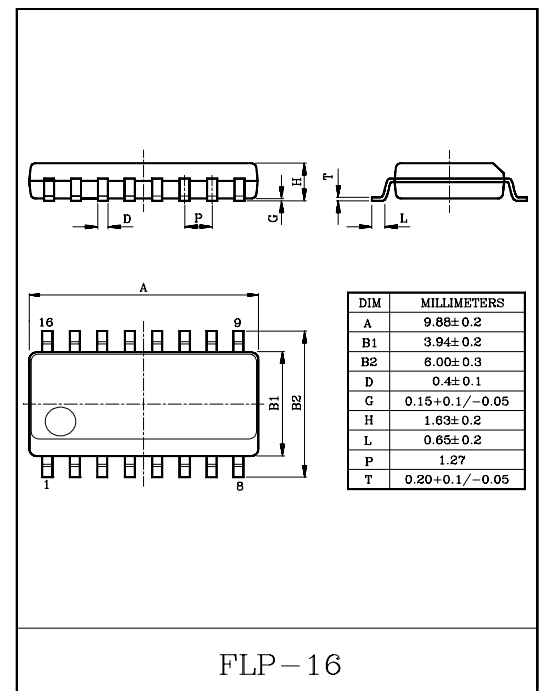
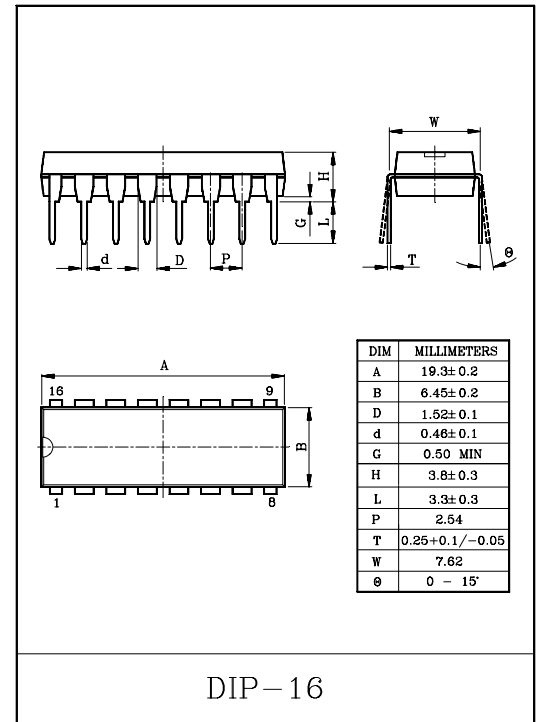

FUNCTION TABLE

INPUT TO OUTPUT CTRL	OUTPUT FUNCTION
$V_I = GND$	Single-ended or paralled output
$V_I = V_{ref}$	Normal push-pull operation

KIA494AP/AF

RECOMMENDED OPERATING CONDITIONS

ITEM	SYMBOL	MIN.	TYP.	MAX.	UNIT
Supply Voltage	V_{CC}	7	-	40	V
Ampified Input Voltage	V_{IN}	-0.3	-	$V_{CC}-2.0$	V
Collector Output Voltage	V_O	-	-	40	V
Output Current (per one stage of output unit)	I_O	-	-	200	mA
Current Into Feedback Terminal	I_{fb}	-	-	0.3	mA
Timing Capacitor	C_T	0.47	-	10,000	nF
Timing Resister	R_T	1.8	-	500	k Ω
Oscillation Frequency	f_{osc}	1	-	300	kHz
Operating Temperature	T_{opr}	-40	-	85	$^{\circ}C$

ELECTRICAL CHARACTERISTICS

REFERENCE VOLTAGE UNIT

CHARACTERISTIC	SYMBOL	TEST CONDITION	MIN.	TYP.	MAX.	UNIT
Output Voltage	V_{ref}	$I_{ref}=1mA, T_a=25^{\circ}C$	4.75	5.00	5.25	V
Input Stability	$R_{eg IN}$	$7V \leq V_{CC} \leq 40V,$ $I_{ref}=1mA, T_a=25^{\circ}C$	-	2	25	mV
Load Stability	$R_{eg L}$	$1mA \leq I_{ref} \leq 10mA, T_a=25^{\circ}C$	-	1	15	
Output Voltage Temp. Change	$T_C V_{ref}$	$-40^{\circ}C \leq T_a \leq 85^{\circ}C, I_{ref}=1mA$	-	0.01	0.03	%/ $^{\circ}C$
Output Short-Circuit Current	I_S	$V_{ref}=0$	-	35	-	mA

OSCILLATION UNIT

CHARACTERISTIC	SYMBOL	TEST CONDITION	MIN.	TYP.	MAX.	UNIT
Oscillation Frequency Set Value	f_{osc}	$C_T=0.001\mu F, R_T=30k\Omega$	-	40	-	kHz
Oscillation Frequency Setting Accuracy	f_{DIV}	$C_T=0.001\mu F, R_T=30k\Omega$	-	3.0	-	%
Frequency Input Stability	f_{VIN}	$7V \leq V_{CC} \leq 40V, T_a=25^{\circ}C$	-	0.1	-	
Frequency Temp. Change	f_{Ta}	$-45^{\circ}C \leq T_a \leq 85^{\circ}C$	-	1	2	

PAUSE PERIOD ADJUSTING UNIT

CHARACTERISTIC	SYMBOL	TEST CONDITION	MIN.	TYP.	MAX.	UNIT
Input Bias Current	I_{IND}	$0 \leq V_{IN} \leq 5.25V$ PIN 4	-	-2	-10	μA
Max. Duty (Each Output Stage)	Dy MAX.	$V_{IN}=0, C_T=0.1\mu F, R_T=12k\Omega$	45	-	-	%
Input Threshold Voltage 1	V_{TH-1}	Output pulse 0% duty	-	2.8	3.3	V
Input Threshold Voltage 2	V_{TH-2}	Output pulse max. duty	0	-	-	

KIA494AP/AF

ERROR AMPLIFIER I, II

CHARACTERISTIC	SYMBOL	TEST CONDITION	MIN.	TYP.	MAX.	UNIT
Input Offset Voltage	V_{IO}	V_O PIN 3=2.5V	-	2	10	mV
Input Offset Current	I_{IO}	V_O PIN 3=2.5V	-	5.0	250	nA
Input Bias Current	I_{IB}	V_O PIN 3=2.5V	-	0.1	1	μ A
In-phase Input Voltage Range	CMR_{IN}	$7V \leq V_{CC} \leq 40V$	0.3	-	$V_{CC}-2$	V
Open Load Gain	G_V	V_O PIN 3=0.5~3.5V, $R_L=2k\Omega$	70	95	-	dB
Unity Gain Frequency	f_o	V_O PIN 3=0.5~3.5V, $R_L=2k\Omega$	-	350	-	kHz
Common-mode rejection Ratio	CMRR	$V_{CC}=40V$	65	90	-	dB
Output Sink Current (Feedback)	I_{O+}	V_O PIN 3=0.7V	0.3	0.7	-	mA
Output Source Current (Feedback)	I_{O+}	V_O PIN 3=3.5V	-2	-10	-	

PWM COMPARATOR

CHARACTERISTIC	SYMBOL	TEST CONDITION	MIN.	TYP.	MAX.	UNIT
Input Threshold Voltage (Feedback)	V_{TH}	Zero duty cycle	-	4	4.5	V
Input Sink Current (Feedback)	I_I	V_O PIN 3=0.7V	0.3	0.7	-	mA

OUTPUT UNIT

CHARACTERISTIC	SYMBOL	TEST CONDITION	MIN.	TYP.	MAX.	UNIT	
Collector off-state Current	$I_{C(off)}$	$V_{CE}=40V, V_{CC}=40V$ Emitter grounded	-	-	100	μ A	
Emitter off-state Current	$I_{E(OFF)}$	$V_{CC}=V_C=40V, V_E=0V$ Emitter follower	-	-	-100		
Emitter Saturation Voltage (Emitter grounded)	$V_{SAT(C)}$	$I_C=200mA, V_E=0V$	-	1.1	1.3	V	
Collector Saturation Voltage (Emitter follower)	$V_{SAT(E)}$	$I_E=-200mA, V_C=15V$	-	1.5	2.5		
Output Voltage Rise Time (Emitter grounded)	t_{r1}		-	100	200	nS	
Output Voltage Fall Time (Emitter follower)	t_{f1}		-	25	100		
Output Voltage Rise Time (Emitter follower)	t_{r2}		-	100	200		
Output Voltage Fall Time (Emitter grounded)	t_{f2}		-	40	100		
Output Control Input Operating Current	"L" State	I_{OCL}	$V_{OC} \leq 0.4V$	-	10	-	μ A
	"H" State	I_{OCH}	$V_{OC}=V_{ref}$	-	0.2	3.5	mA

CURRENT CONSUMPTION (TOTAL)

CHARACTERISTIC	SYMBOL	TEST CONDITION	MIN.	TYP.	MAX.	UNIT
Standby Current	$I_{CC(S-B)}$	$V_{CC}=15V,$ Other terminal opened	-	6	10	mA
Average Supply Current	I_{CC} total	$V_{(PIN4)}=2V, C_T=0.01\mu F$ $R_T=12k\Omega, V_{CC}=15V$	-	7.5	-	

KIA494AP/AF

BLOCK DIAGRAM

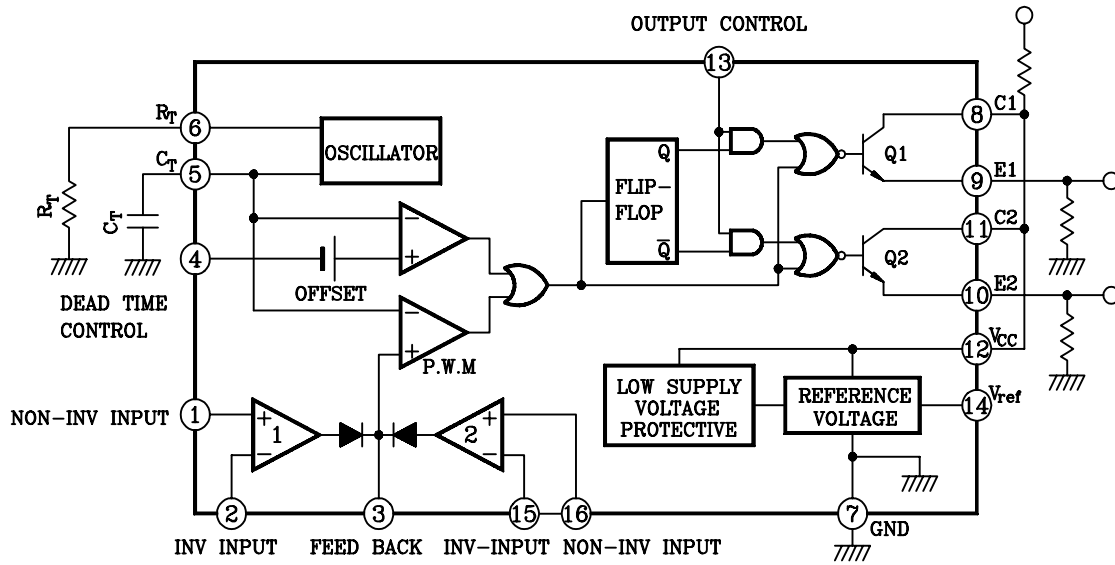

(Note) PIN (13) BECOMES SINGLE MODE AT "L" AND PUSH-PULL MODE AT "H"

OPERATING WAVEFORM

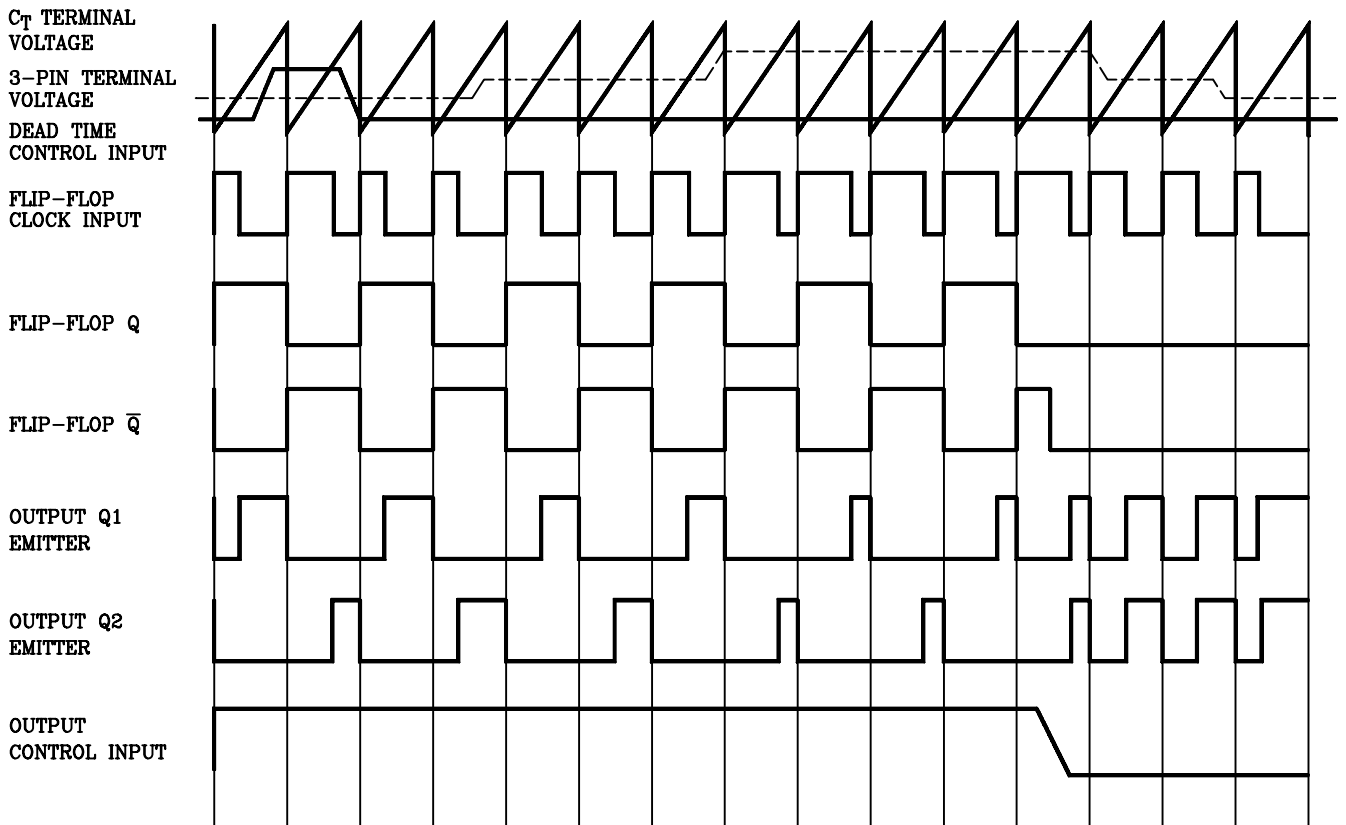

KIA494AP/AF

TEST CIRCUIT

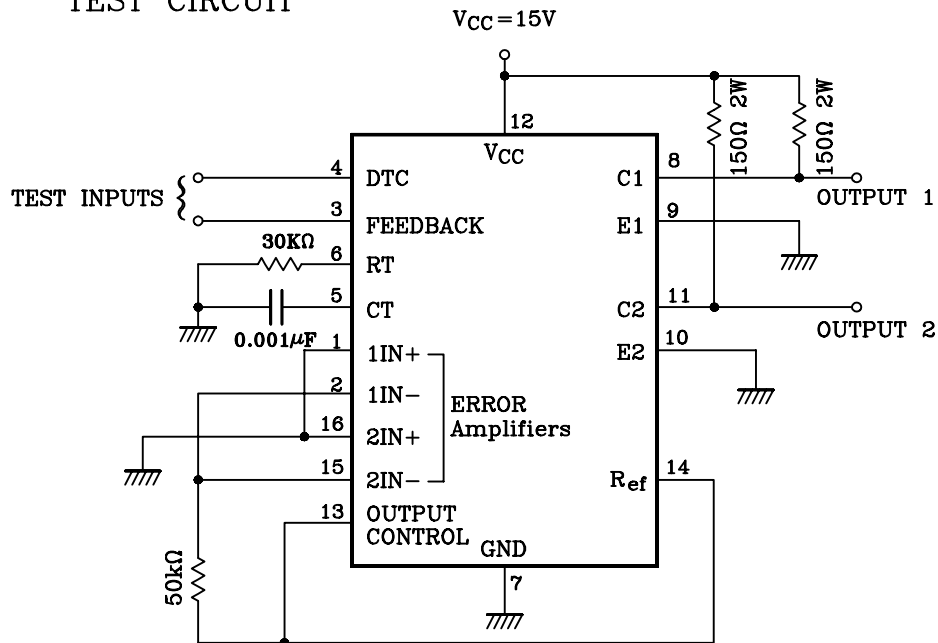

Error Amplifier Characteristics

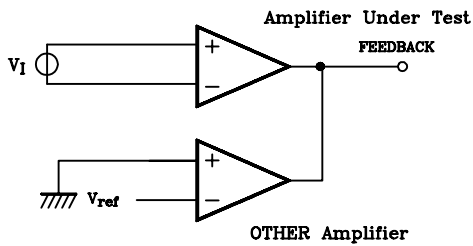

Common-Emitter Configuration Test Circuit and Waveform

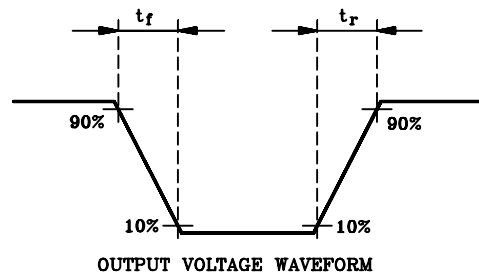
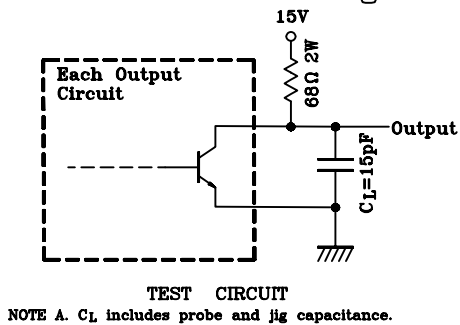

Emitter-Follower Configuration Test Circuit and Waveform

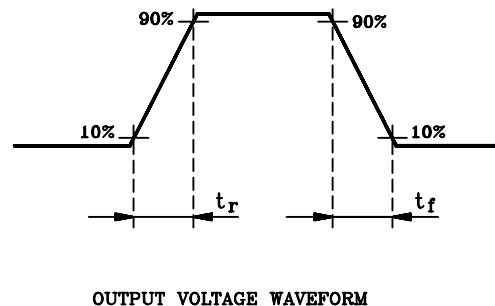
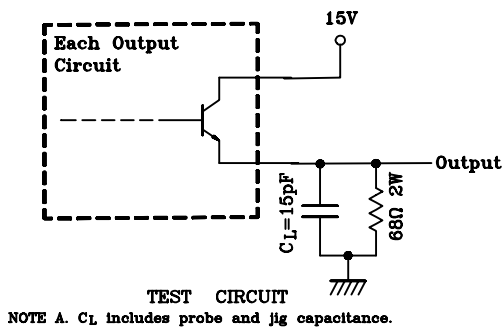

KIA494AP/AF

