

HIGH FREQUENCY LOW NOISE AMPLIFIER APPLICATION.  
VHF BAND AMPLIFIER APPLICATION.

### FEATURES

- Small Reverse Transfer Capacitance  
:  $C_{re}=0.7\text{pF(Typ.)}$
- Low Noise Figure :  $NF=2.5\text{dB(Typ.)}$  ( $f=100\text{MHz}$ ).

### MAXIMUM RATING (Ta=25°C)

CHARACTERISTIC	SYMBOL	RATING	UNIT
Collector-Base Voltage	$V_{CBO}$	40	V
Collector-Emitter Voltage	$V_{CEO}$	30	V
Emitter-Base Voltage	$V_{EBO}$	4	V
Collector Current	$I_C$	20	mA
Emitter Current	$I_E$	-20	mA
Collector Power Dissipation	$P_C$	100	mW
Junction Temperature	$T_j$	150	°C
Storage Temperature Range	$T_{stg}$	-55 ~ 150	°C

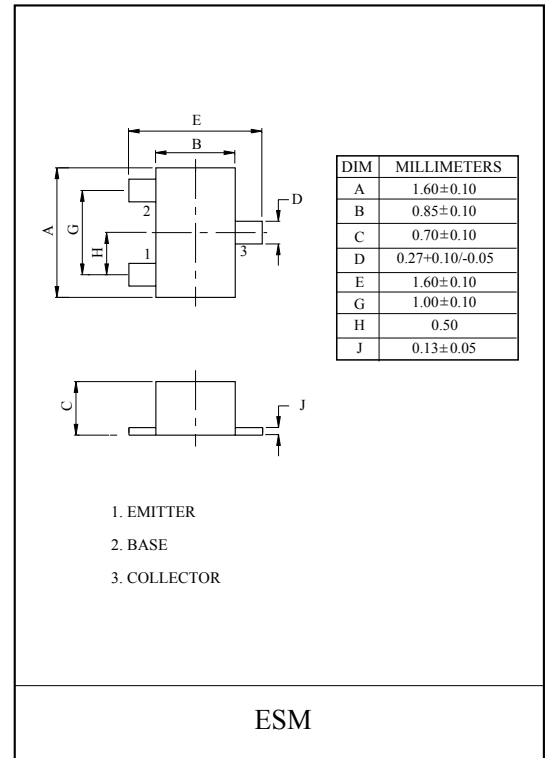

### Marking

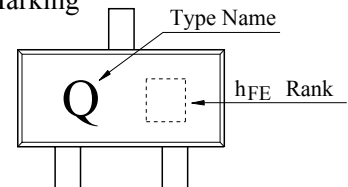

### ELECTRICAL CHARACTERISTICS (Ta=25°C)

CHARACTERISTIC	SYMBOL	TEST CONDITION	MIN.	TYP.	MAX.	UNIT
Collector Cut-off Current	$I_{CBO}$	$V_{CB}=18\text{V}, I_E=0$	-	-	0.5	$\mu\text{A}$
Emitter Cut-off Current	$I_{EBO}$	$V_{EB}=4\text{V}, I_C=0$	-	-	0.5	$\mu\text{A}$
DC Current Gain	$h_{FE}(\text{Note})$	$V_{CE}=6\text{V}, I_C=1\text{mA}$	40	-	200	
Reverse Transfer Capacitance	$C_{re}$	$V_{CE}=6\text{V}, f=1\text{MHz}$	-	0.7	-	pF
Transition Frequency	$f_T$	$V_{CE}=6\text{V}, I_C=1\text{mA}$	300	550	-	MHz
Collector-Base Time Constant	$C_C \cdot r_{bb}$	$V_{CB}=6\text{V}, I_E=-1\text{mA}, f=30\text{MHz}$	-	-	30	pS
Noise Figure	NF	$V_{CC}=6\text{V}, I_E=-1\text{mA}$ $f=100\text{MHz (Fig.)}$	-	2.5	5.0	dB
Power Gain	$G_{pe}$		15	18	-	

Note :  $h_{FE}$  Classification R(1):40 ~ 80 , O(2):70 ~ 140 , Y(4):100 ~ 200

# KTC4080E

Fig.  $G_{pe}$  TEST CIRCUIT

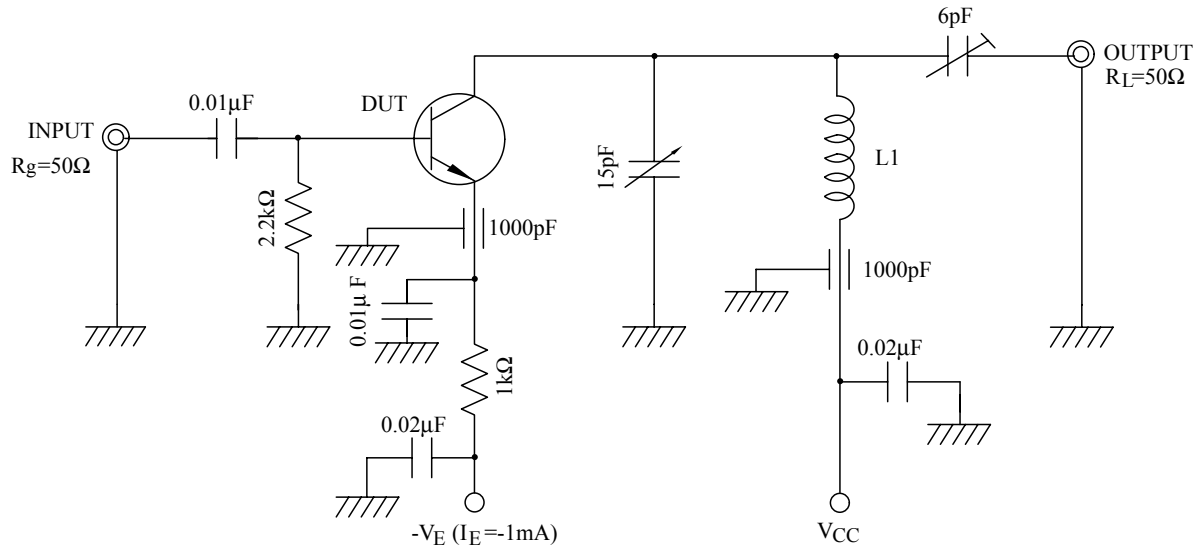

L1 : 0.8mm $\Phi$  SILVER PLATED COPPER WIRE, 4Turns.  
10mm ID, 8mm Length.

y PARAMETERS (Typ.)

(1) COMMON EMITTER ( $V_{CE}=6V$ ,  $I_E=-1mA$ ,  $f=100MHz$ )

CHARACTERISTIC	SYMBOL	TYP.	UNIT
Input Conductance	$g_{ie}$	2.9	mS
Input Capacitance	$C_{ie}$	10.2	pF
Reverse Transfer Admittance	$ y_{re} $	0.33	$\mu S$
Phase Angle of Reverse Transfer Admittance	$\theta_{re}$	-90	$^{\circ}$
Forward Transfer Admittance	$ y_{fe} $	40	mS
Phase Angle of Forward Transfer Admittance	$\theta_{fe}$	-20	$^{\circ}$
Output Conductance	$g_{oe}$	45	$\mu S$
Output Capacitance	$C_{oe}$	1.1	pF

(2) COMMON BASE ( $V_{CE}=6V$ ,  $I_E=-1mA$ ,  $f=100MHz$ )

CHARACTERISTIC	SYMBOL	TYP.	UNIT
Input Conductance	$g_{ib}$	34	mS
Input Capacitance	$C_{ib}$	-10	pF
Reverse Transfer Admittance	$ y_{rb} $	0.27	$\mu S$
Phase Angle of Reverse Transfer Admittance	$\theta_{rb}$	-105	$^{\circ}$
Forward Transfer Admittance	$ y_{fb} $	34	mS
Phase Angle of Forward Transfer Admittance	$\theta_{fb}$	165	$^{\circ}$
Output Conductance	$g_{ob}$	45	$\mu S$
Output Capacitance	$C_{ob}$	1.1	pF

# KTC4080E

## STATIC CHARACTERISTICS

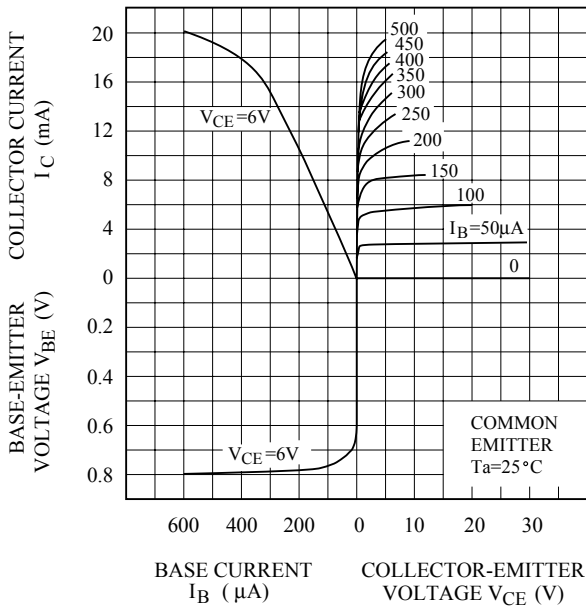

## $h_{FE} - I_C$

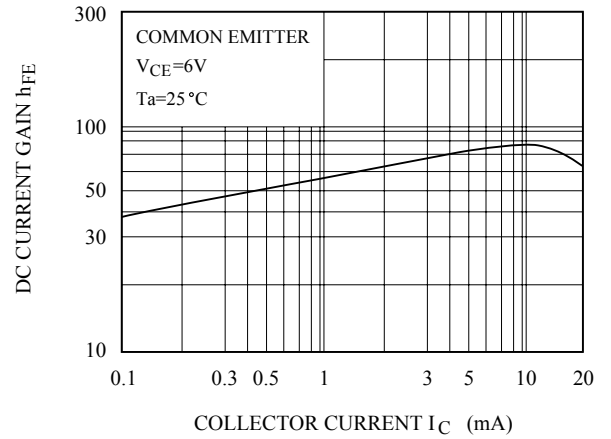

## $C_{ie}, g_{ie} - I_E$

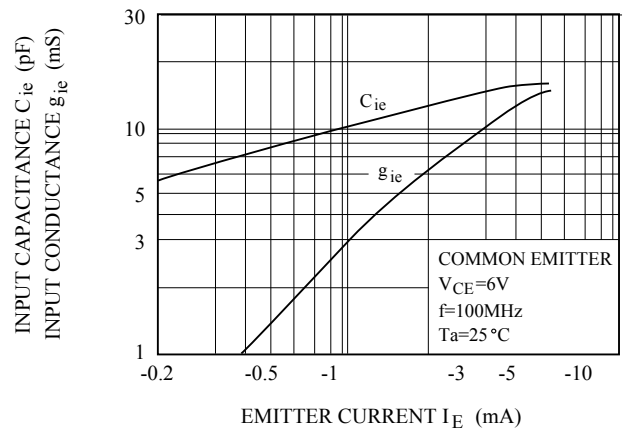

## $C_{oe}, g_{oe} - I_E$

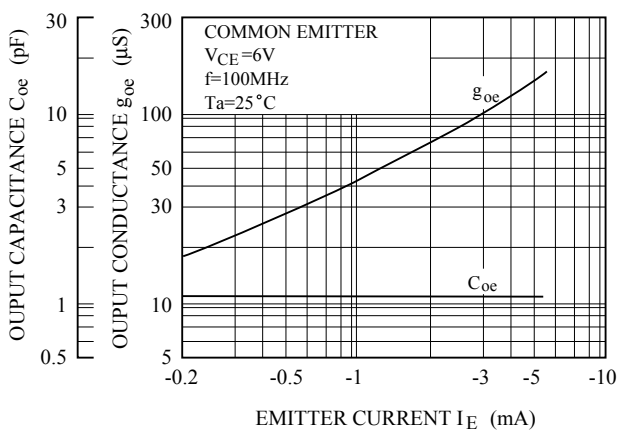

## $|y_{re}|, \Theta_{re} - I_E$

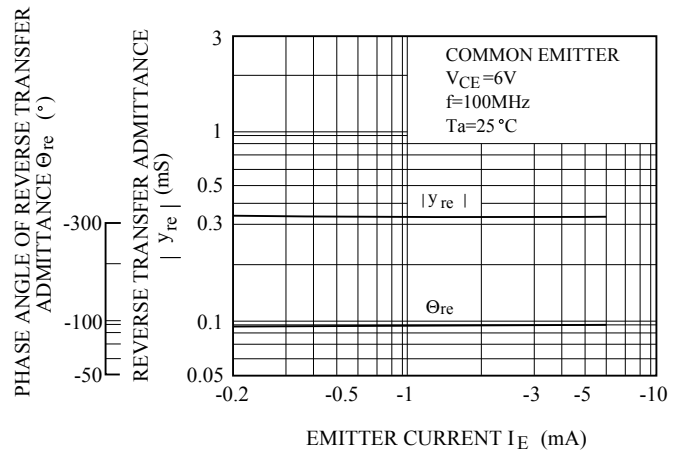

# KTC4080E

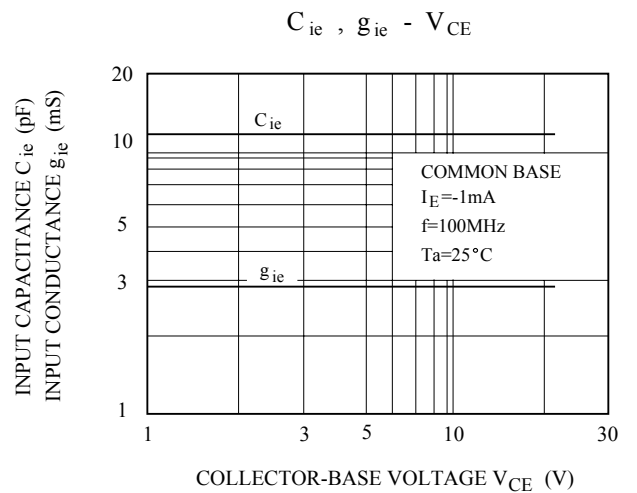
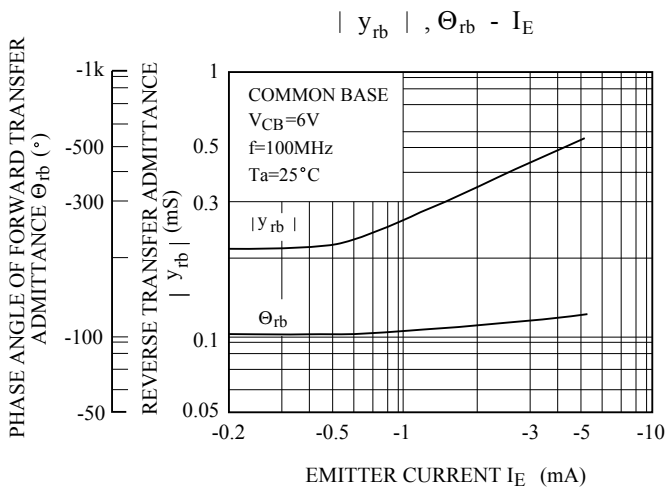
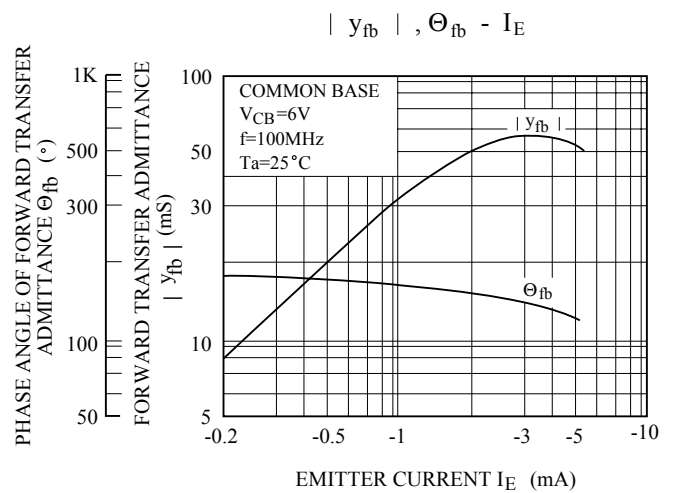
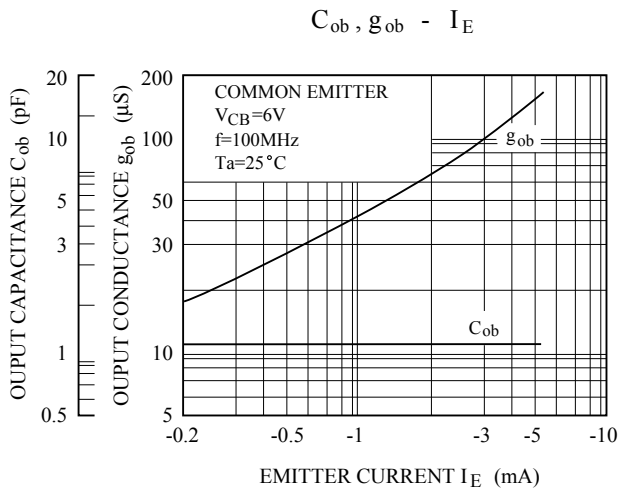
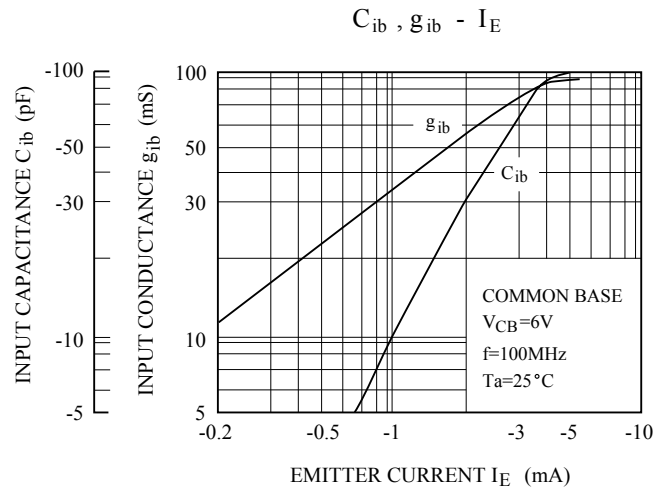
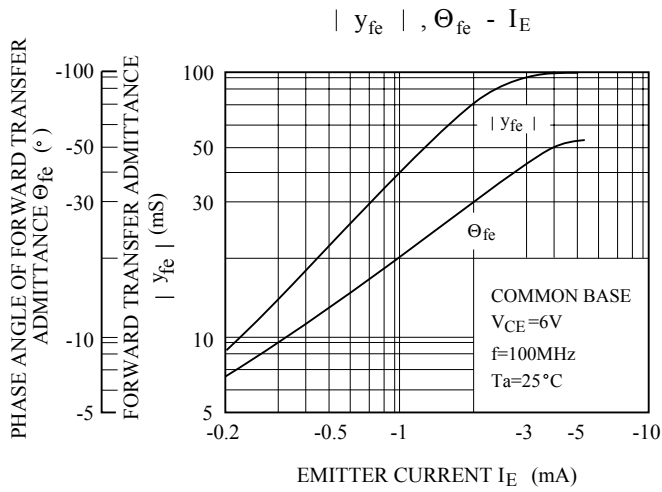

# KTC4080E

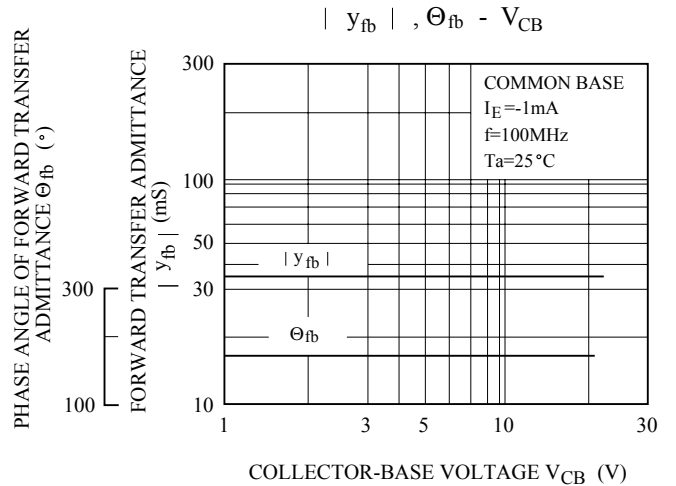
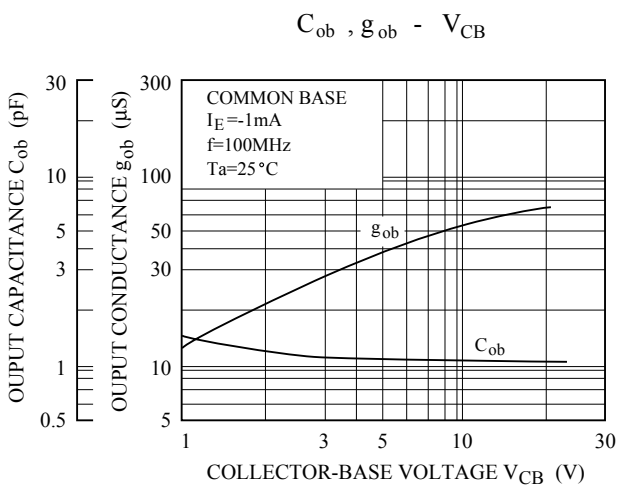
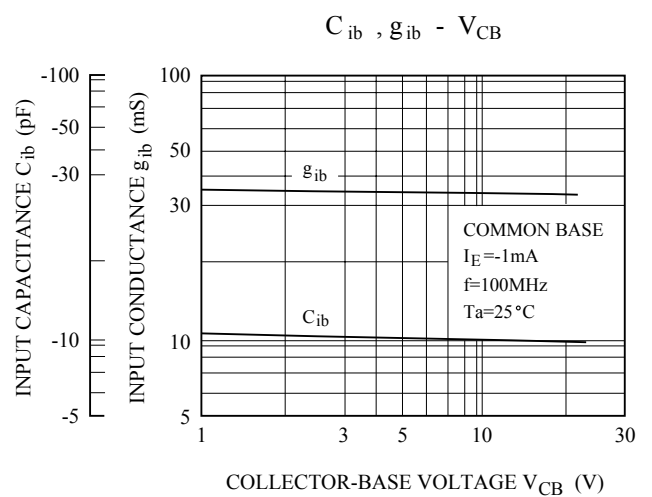
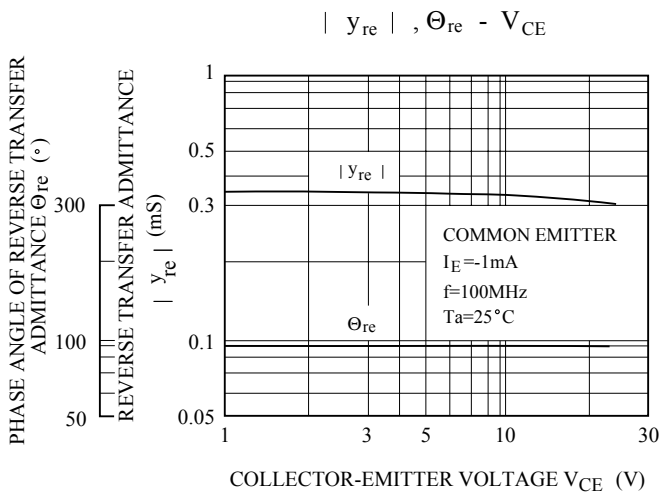
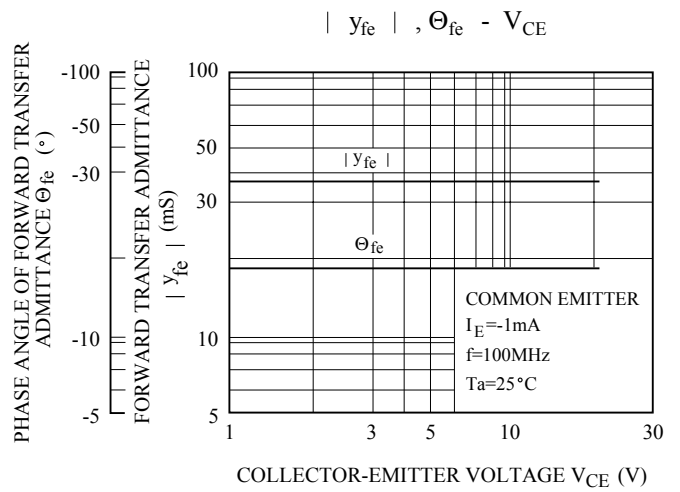
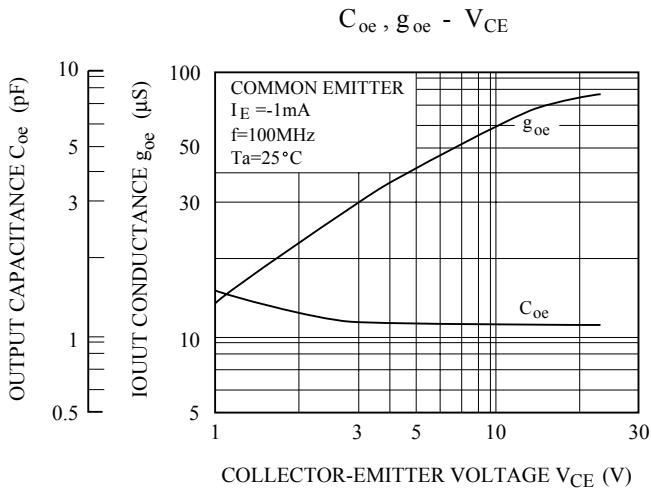

# KTC4080E

