

TOSHIBA FIELD EFFECT TRANSISTOR
GaAs N CHANNEL SINGLE GATE MODULATION DOPE TYPE

2SK2496

SHF BAND LOW NOISE AMPLIFIER APPLICATIONS

Unit in mm

- Low Noise Figure : NF=0.9dB (f=12GHz)
- High Gain : Ga=11dB (f=12GHz)

MAXIMUM RATINGS (Ta = 25°C)

CHARACTERISTIC	SYMBOL	RATING	UNIT
Gate-Drain Voltage	V _{GDO}	-3	V
Gate-Source Voltage	V _{GSO}	-3	V
Drain Current	I _D	80	mA
Power Dissipation	P _D	150	mW
Channel Temperature	T _{ch}	125	°C
Storage Temperature Range	T _{stg}	-55~125	°C

Marking

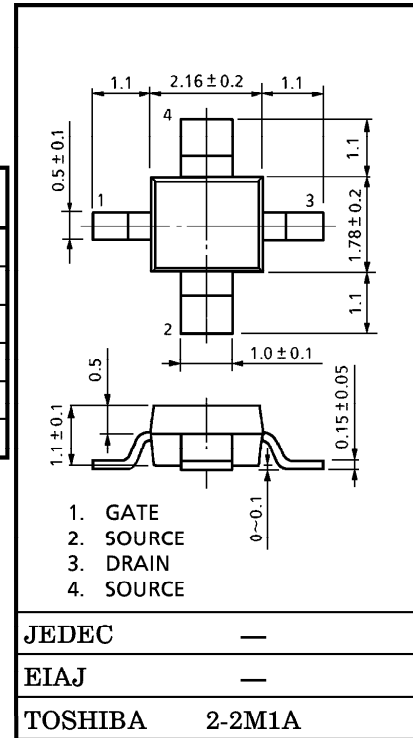
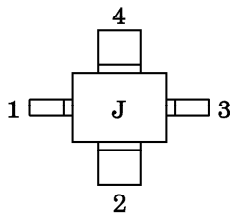

JEDEC	—
EIAJ	—
TOSHIBA	2-2M1A

Weight : 0.016g (Typ.)

ELECTRICAL CHARACTERISTICS (Ta = 25°C)

CHARACTERISTIC	SYMBOL	TEST CONDITION	MIN.	TYP.	MAX.	UNIT
Gate Leakage Current	I _{GSS}	V _{DS} =0, V _{GS} =-2V	—	—	-20	μA
Drain Current	I _{DSS}	V _{DS} =2V, V _{GS} =0	20	40	80	mA
Gate-Source Cut-off Voltage	V _{GS(OFF)}	V _{DS} =2V, I _D =100μA	-0.2	-0.8	-2	V
Forward Transfer Admittance	Y _{fs}	V _{DS} =2V, I _D =15mA, f=1kHz	—	80	—	mS
Noise Figure	NF	V _{DS} =2V, I _D =15mA, f=12GHz	—	0.9	1.2	dB
Associated Gain	Ga	V _{DS} =2V, I _D =15mA, f=12GHz	10	11	—	dB

CAUTION

GaAs (Gallium Arsenide) is used in this product. The dust or vapor can be dangerous to humans. Do not break, cut, crush or dissolve chemically. Dispose of this product properly according to law. Do not intermingle with normal industrial or domestic waste.

This device electrostatic sensitivity. Please handle with caution.

961001EAC2

- TOSHIBA is continually working to improve the quality and the reliability of its products. Nevertheless, semiconductor devices in general can malfunction or fail due to their inherent electrical sensitivity and vulnerability to physical stress. It is the responsibility of the buyer, when utilizing TOSHIBA products, to observe standards of safety, and to avoid situations in which a malfunction or failure of a TOSHIBA product could cause loss of human life, bodily injury or damage to property. In developing your designs, please ensure that TOSHIBA products are used within specified operating ranges as set forth in the most recent products specifications. Also, please keep in mind the precautions and conditions set forth in the TOSHIBA Semiconductor Reliability Handbook.
- Gallium arsenide (GaAs) is a substance used in the products described in this document. GaAs dust and fumes are toxic. Do not break, cut or pulverize the product, or use chemicals to dissolve them. When disposing of the products, follow the appropriate regulations. Do not dispose of the products with other industrial waste or with domestic garbage.
- The information contained herein is presented only as a guide for the applications of our products. No responsibility is assumed by TOSHIBA CORPORATION for any infringements of intellectual property or other rights of the third parties which may result from its use. No license is granted by implication or otherwise under any intellectual property or other rights of TOSHIBA CORPORATION or others.
- The information contained herein is subject to change without notice.

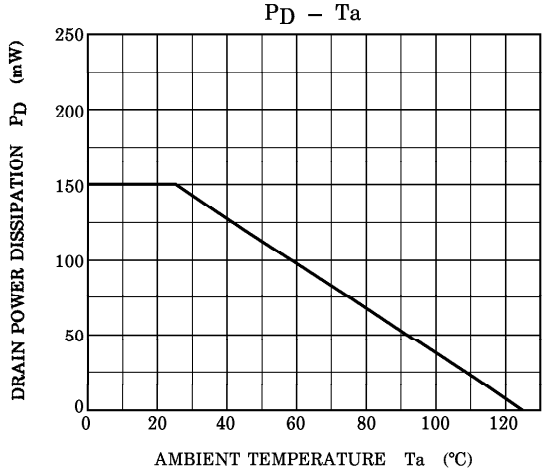
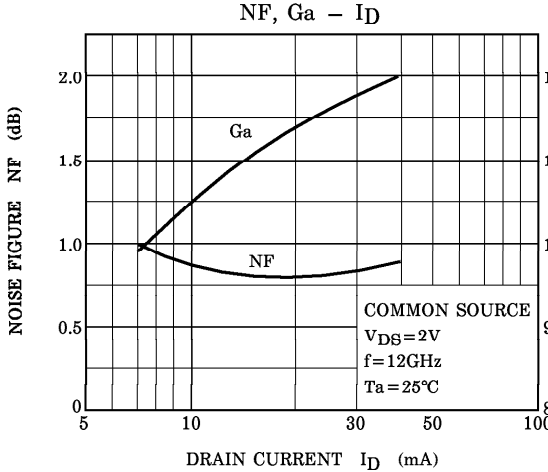
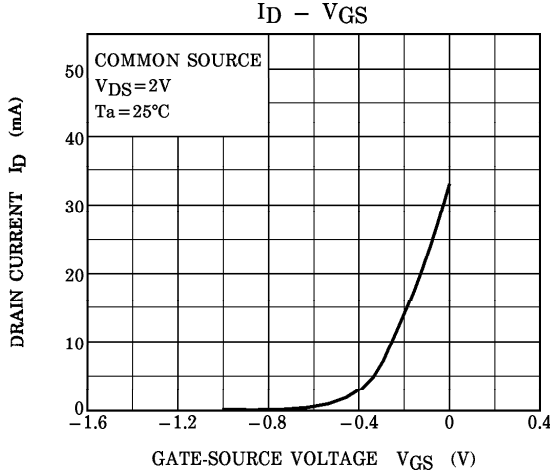
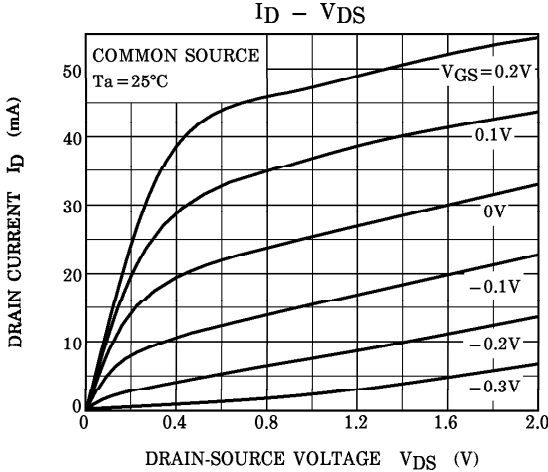

S-PARAMETER

COMMON SOURCE

($V_{DS}=2V$, $I_D=15mA$, $T_a=25^\circ C$, $Z_o=50\Omega$)

FREQ. (MHz)	S ₁₁		S ₂₁		S ₁₂		S ₂₂	
	MAG	ANG	MAG	ANG	MAG	ANG	MAG	ANG
2000	0.934	-27	5.446	148	0.040	76	0.381	-15
3000	0.867	-43	5.286	134	0.058	70	0.345	-27
4000	0.791	-60	5.123	117	0.076	58	0.298	-38
5000	0.704	-80	4.897	97	0.096	47	0.231	-53
6000	0.616	-101	4.578	83	0.108	38	0.162	-73
7000	0.544	-122	4.201	68	0.120	27	0.117	-95
8000	0.477	-144	3.843	53	0.127	17	0.075	-126
9000	0.422	-172	3.510	36	0.132	3	0.066	148
10000	0.415	162	3.228	22	0.139	-5	0.124	114
11000	0.433	142	3.038	9	0.144	-15	0.169	100
12000	0.458	117	2.805	-10	0.151	-29	0.225	80
13000	0.493	95	2.606	-25	0.151	-41	0.284	64
14000	0.539	74	2.430	-44	0.153	-56	0.331	51
15000	0.605	51	2.174	-64	0.154	-73	0.417	33
16000	0.670	30	1.837	-80	0.140	-86	0.505	17

S₁₁
COMMON SOURCE
V_{DS}=2V
I_D=15mA
T_a=25°C
(UNIT : Ω)

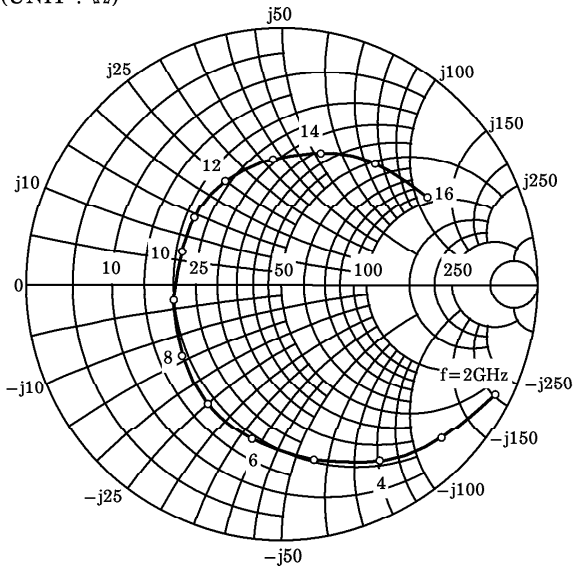

S₂₁
COMMON SOURCE
V_{DS}=2V
I_D=15mA
T_a=25°C

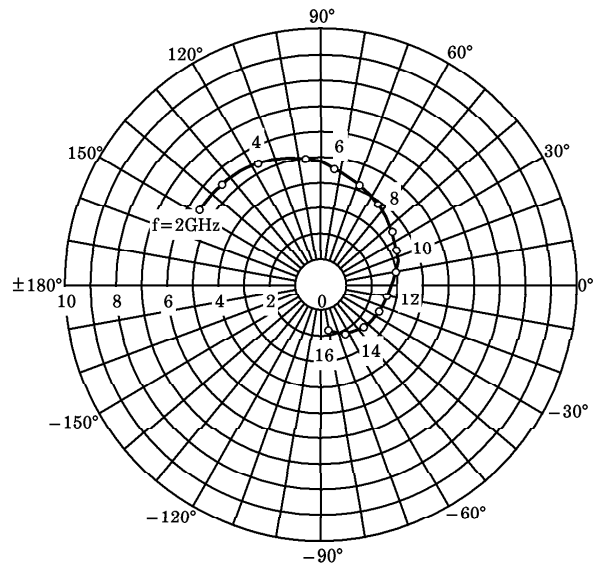

S₁₂
COMMON SOURCE
V_{DS}=2V
I_D=15mA
T_a=25°C

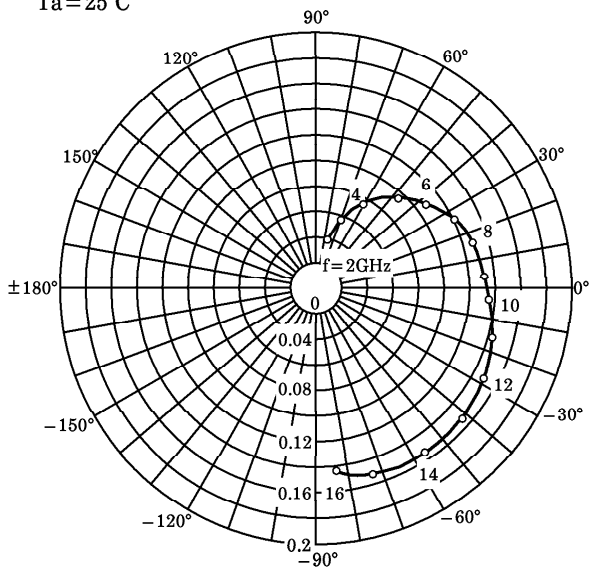

S₂₂
COMMON SOURCE
V_{DS}=2V
I_D=15mA
T_a=25°C
(UNIT : Ω)

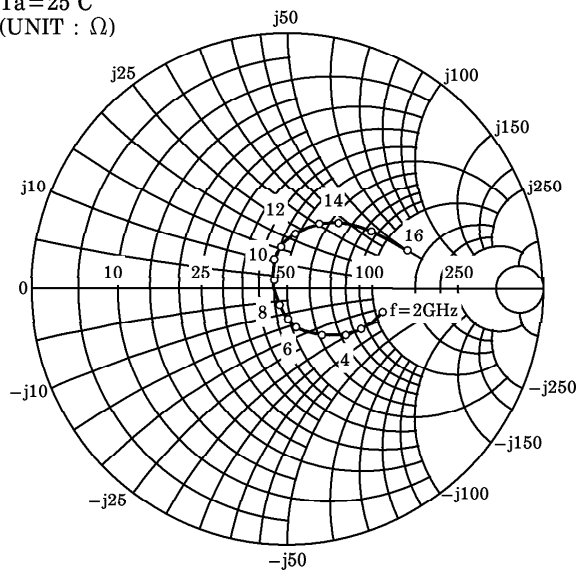

CONSTANT NOISE FIGURE

NF min = 0.65dB, $\Gamma_{opt} = 0.16 \angle 164$, $R_n = 4.7\Omega$

@ $V_{DS} = 2V$, $I_D = 15mA$, $f = 12GHz$

$T_a = 25^\circ C$, $Z_0 = 50\Omega$

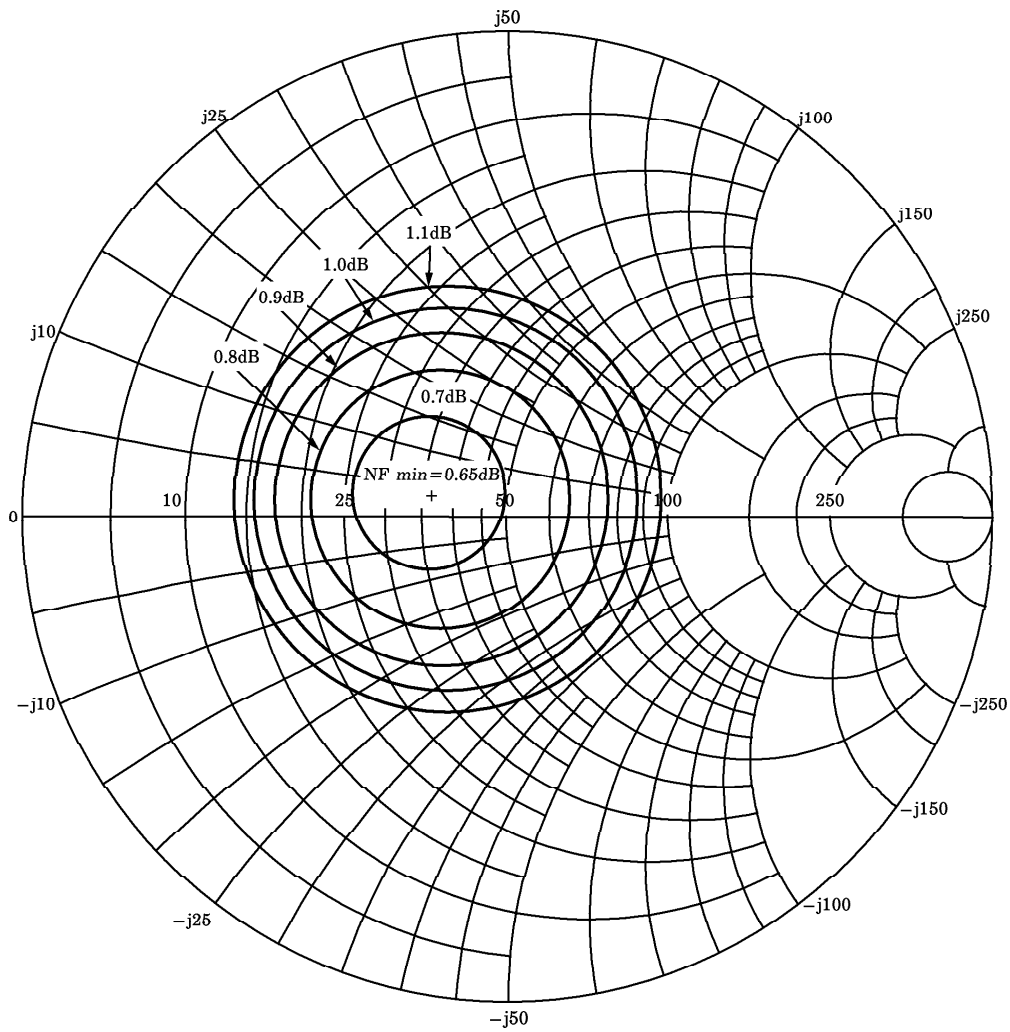

Recommended Methods of Mounting for This Device

Mounting method				
Solder flow	Nearinfrared reflow	Farinfrared reflow	VPS & hot air reflow	Soldering iron
×	○	◎	◎	○

◎ : Applicable

○ : Applicable only once

× : Not applicable; other methods are recommended.

Note 1 : For either method of mounting, the above table shows whether applicable or not under Toshiba's recommended mounting conditions.

Note 2 : When mounted a number of times, those marked by ◎ can only be used. In this case, mounting is allowed up to three times, with the interval from the first to the third mounting completed within 24 hours.