

# TLP3213

MEASUREMENT INSTRUMENTS

LOGIC IC TESTERS / MEMORY TESTERS

BOARD TESTERS / SCANNERS

The TOSHIBA TLP3213 is a super small-outline photorelay, suitable for surface-mount assembly. The TLP3213 consists of a GaAs infrared-emitting diode optically coupled to a photo-MOS FET and housed in a 4-pin package. Its characteristics include low OFF-state current and low output pin capacitance, enabling it to be used in high-frequency measuring instruments.

**FEATURES**

- 4 pin SSOP (SSOP4) : 1.8 mm high, 1.27 mm pitch
- 1-Form-A
- Peak Off-State Voltage : 40 V (MIN.)
- Trigger LED Current : 4 mA (MAX.)
- On-State Current : 80 mA (MAX.)
- On-State Resistance : 35 (MAX.), 25 (TYP.)
- Output Capacitance : 1.4 pF (MAX.), 0.6 pF (TYP.)
- Isolation Voltage : 1500 Vrms (MIN.)

**PIN CONFIGURATION (TOP VIEW)**

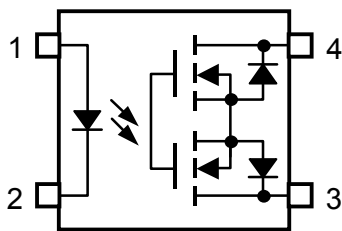

- 1 : ANODE
- 2 : CATHODE
- 3 : DRAIN
- 4 : DRAIN

Unit: mm

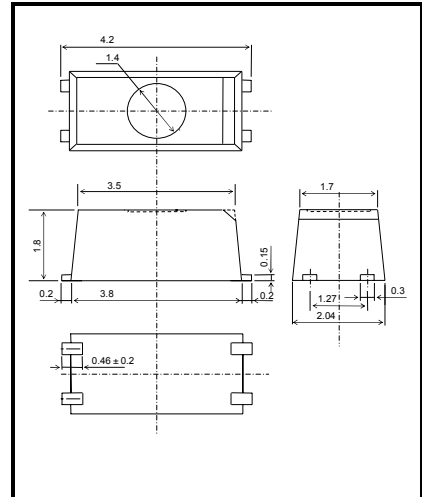

JEDEC	
EIAJ	
TOSHIBA	11-2A1

Weight: 0.03 g

## MAXIMUM RATINGS (Ta = 25°C)

CHARACTERISTIC		SYMBOL	RATING	UNIT
LED	Forward Current	I <sub>F</sub>	50	mA
	Forward Current Derating (Ta ≥ 25°C)	ΔI <sub>F</sub> /°C	-0.5	mA/°C
	Reverse Voltage	V <sub>R</sub>	5	V
	Junction Temperature	T <sub>j</sub>	125	°C
DETECTOR	Off-State Output Terminal Voltage	V <sub>OFF</sub>	40	V
	On-State Current	I <sub>ON</sub>	80	mA
	On-State Current Derating (Ta ≥ 25°C)	ΔI <sub>ON</sub> /°C	-0.8	mA/°C
	Junction Temperature	T <sub>j</sub>	125	°C
Storage Temperature Range		T <sub>stg</sub>	-40~125	°C
Operating Temperature Range		T <sub>opr</sub>	-20~85	°C
Lead Soldering Temperature (10 s)		T <sub>sol</sub>	260	°C
Isolation Voltage (AC, 1 minute, R.H. ≤ 60%) (NOTE1)		BV <sub>S</sub>	1500	V <sub>rms</sub>

(NOTE1) : Device considered a two-terminal device : Pins 1 and, 2 shorted together, and pins 3 and 4 shorted together.

## Caution

This device is sensitive to electrostatic discharge. When using this device, please ensure that all tools and equipment are earthed.

This device is applying super small package which is free for Moisture-Proof packing. However, the application of this device is premised on use under controlled environmental condition like as measuring instrument. It is necessary to take precautions of storage condition and operating environmental condition.

## RECOMMENDED OPERATING CONDITIONS

CHARACTERISTIC	SYMBOL	MIN.	TYP.	MAX.	UNIT
Supply Voltage	V <sub>DD</sub>	—	—	32	V
Forward Current	I <sub>F</sub>	10	—	30	mA
On-State Current	I <sub>ON</sub>	—	—	80	mA
Operating Temperature	T <sub>opr</sub>	25	—	60	°C

## INDIVIDUAL ELECTRICAL CHARACTERISTICS (Ta = 25°C)

CHARACTERISTIC		SYMBOL	TEST CONDITION	MIN.	TYP.	MAX.	UNIT
LED	Forward Voltage	V <sub>F</sub>	I <sub>F</sub> = 10 mA	1.0	1.15	1.3	V
	Reverse Current	I <sub>R</sub>	V <sub>R</sub> = 5 V	—	—	10	μA
	Capacitance	C <sub>T</sub>	V = 0, f = 1 MHz	—	15	—	pF
DETECTOR	Off-State Current	I <sub>OFF</sub>	V <sub>OFF</sub> = 30 V, Ta = 50°C	—	—	1000	pA
	Capacitance	C <sub>OFF</sub>	V = 0, f = 100 MHz, t < 1 s	—	0.6	1.4	pF

**COUPLED ELECTRICAL CHARACTERISTICS (Ta = 25°C)**

CHARACTERISTIC	SYMBOL	TEST CONDITION	MIN.	TYP.	MAX.	UNIT
Trigger LED Current	$I_{FT}$	$I_{ON} = 80 \text{ mA}$	—	—	4	mA
Return LED Current	$I_{FC}$	$I_{OFF} = 10 \text{ } \mu\text{A}$	0.2	0.75	—	mA
On-State Resistance	$R_{ON}$	$I_{ON} = 80 \text{ mA}, I_F = 5 \text{ mA}, t < 1 \text{ s}$	—	25	35	$\Omega$

**ISOLATION CHARACTERISTICS (Ta = 25°C)**

CHARACTERISTIC	SYMBOL	TEST CONDITION	MIN.	TYP.	MAX.	UNIT
Capacitance Input to Output	$C_S$	$V_S = 0 \text{ V}, f = 1 \text{ MHz}$	—	0.8	—	pF
Isolation Resistance	$R_S$	$V_S = 500 \text{ V}, \text{R.H.} \leq 60\%$	$5 \times 10^{10}$	$10^{14}$	—	$\Omega$
Isolation Voltage	$BV_S$	AC, 1 minute	1500	—	—	Vrms
		AC, 1 second (in oil)	—	3000	—	—
		DC, 1 minute (in oil)	—	3000	—	Vdc

**SWITCHING CHARACTERISTICS (Ta = 25°C)**

CHARACTERISTIC	SYMBOL	TEST CONDITION	MIN.	TYP.	MAX.	UNIT
Turn-on Time	$t_{ON}$	$R_L = 200 \text{ } \Omega$ (NOTE 4) $V_{DD} = 10 \text{ V}, I_F = 5 \text{ mA}$	—	50	500	$\mu\text{s}$
Turn-off Time	$t_{OFF}$		—	90	500	

(NOTE 4) : SWITCHING TIME TEST CIRCUIT

