

## Cordless Telephone-Signal Processor

### Description

The programmable cordless phone-signal processor includes all necessary low-frequency parts such as microphone- and earphone amplifier, compander, pre-emphasis, deemphasis, scrambler, FSK modem, power-supply management, as well as RF receiving parts

such as IF converter, FM demodulator, RSSI. Several gains and mutes in transmit and receive direction are controlled by a serial bus while compander, pre- and deemphasis and scrambler can be bypassed.

### Features

#### RF Receiver Part

- IF converter
- FM demodulator
- RSSI

#### Low-Frequency Part

- Symmetrical input of microphone amplifier
- Symmetrical output of earpiece amplifier

- Compander
- Pre- and deemphasis
- Scrambler
- Data management by FSK coding
- Power-supply management
- Serial bus

**Application:** CT1, CT1 plus, 900 MHz USA

### Block Diagram

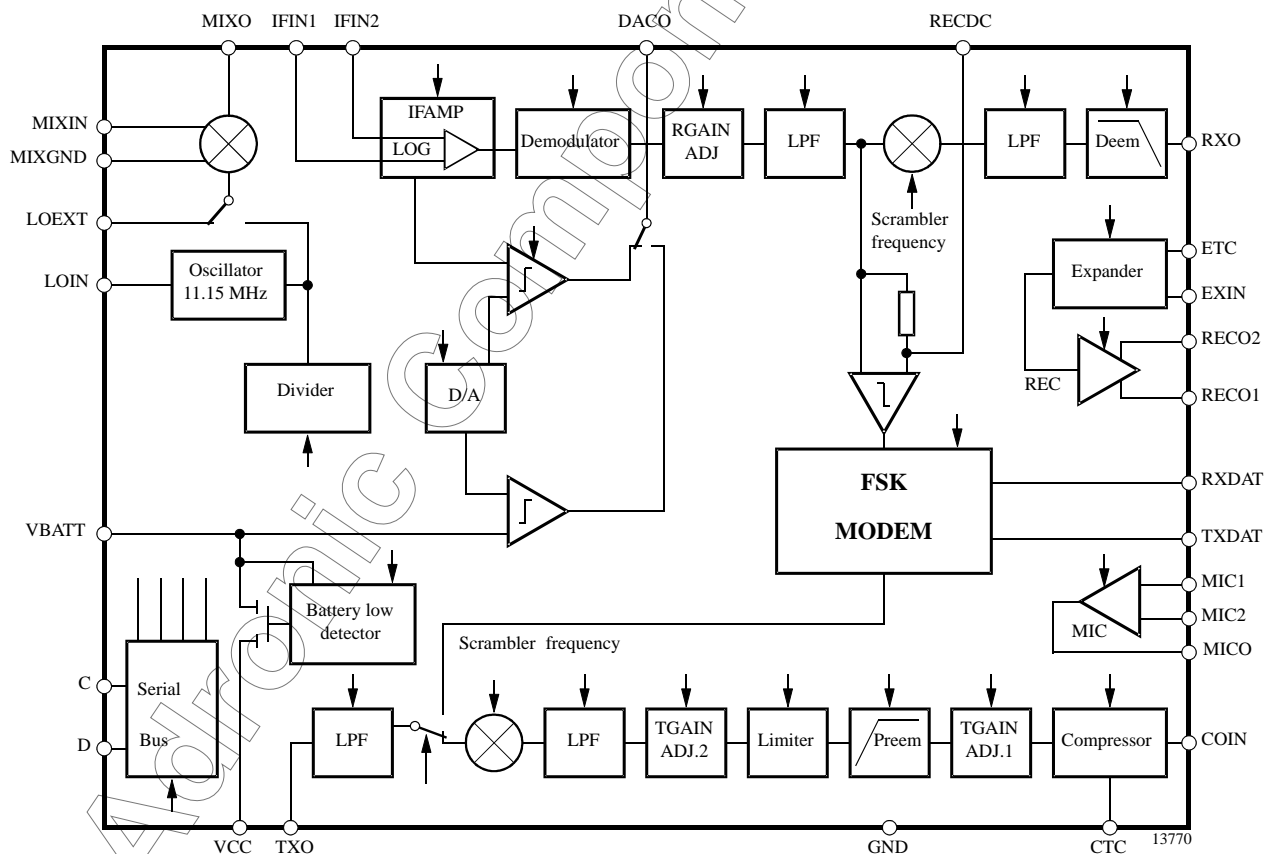

Figure 1. Block diagram

## Ordering Information

Extended Type Number	Package	Remarks
U3501BM	SO28	

## Pin Description

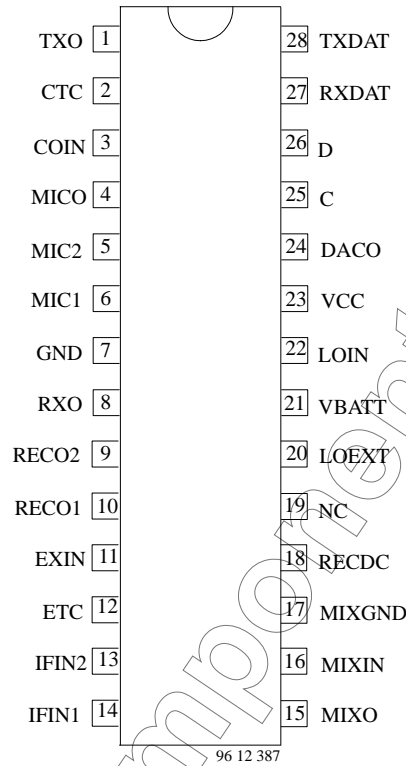
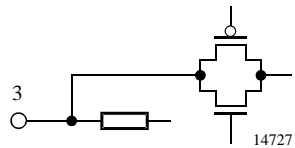
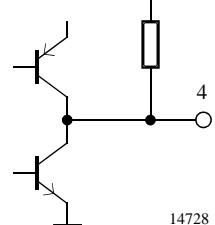
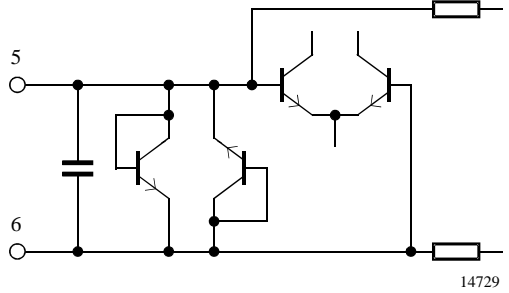
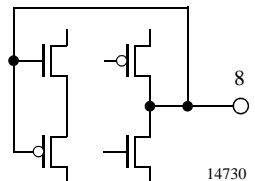
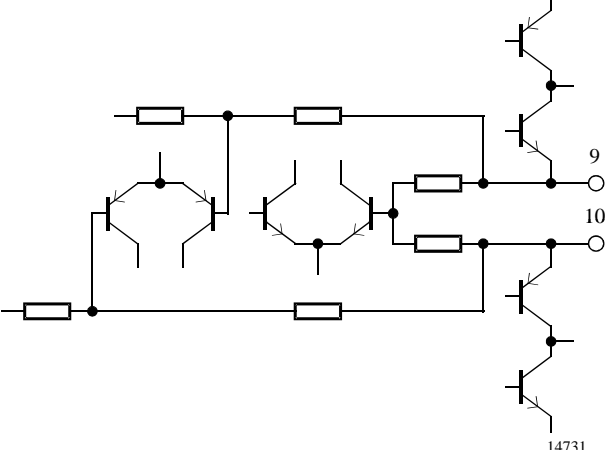

Figure 2. Pinning

Pin	Symbol	Function	Configuration
1	TXO	Transmit section analog output	
2	CTC	Compressor time constant control analog output	

Pin	Symbol	Function	Configuration
3	COIN	Compressor analog input	
4	MICO	Microphone amplifier output	
5	MIC2	Non-inverting input of microphone amplifier	
6	MIC1	Inverting input of microphone amplifier	
7	GND	LF analog/ digital ground	
8	R XO	Intermediate receive analog output	
9	RECO2	Symmetrical output of receive amplifier	
10	RECO1	Symmetrical output of receive amplifier	

Adi

Pin	Symbol	Function	Configuration
11	EXIN	Expander analog input	
12	ETC	Expander time constant control analog output	
13	IFIN2	Symmetrical IF amplifier input	
14	IFIN1	Symmetrical IF amplifier input	
15	MIXO	Mixer output	
16	MIXIN	Mixer input	
17	MIXGND	IF amplifier and mixer ground	

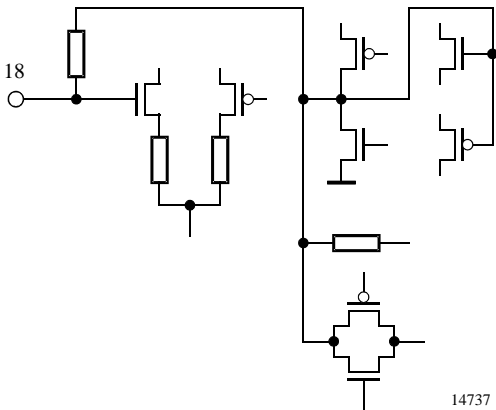
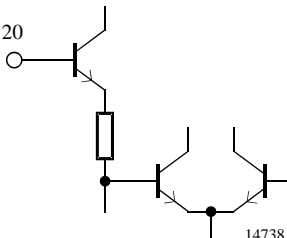
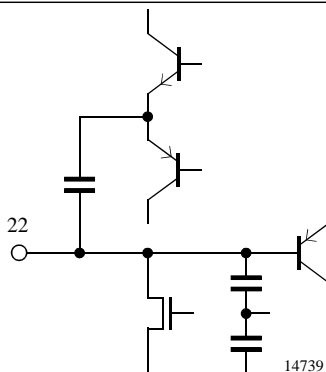
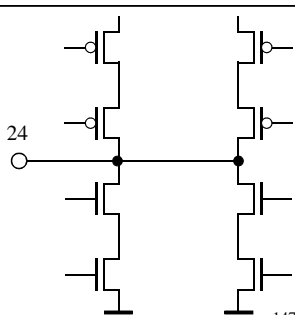
Pin	Symbol	Function	Configuration
18	RE CDC	Reference-voltage generation for FSK demodulator	 <p>14737</p>
19	NC	Not connected	
20	LOEXT	External LO input	 <p>14738</p>
21	VBATT	Battery supply	
22	LOIN	Local oscillator input for TCO or SC filter oscillator: 11.15 MHz	 <p>14739</p>
23	VCC	Supply-voltage output for peripherals and internal supply of digital part	
24	DACO	D/A comparator output	 <p>14740</p>

Pin	Symbol	Function	Configuration
25	C	Clock input of serial bus	
26	D	Data input of serial bus	
27	RXDAT	Receive data digital output	
28	TXDAT	Transmit data digital input	

## Absolute Maximum Ratings

Parameters	Symbol	Value	Unit
Supply voltage	$V_{Batt}, V_{CC}$	5.5	V
Junction temperature	$T_j$	+125	°C
Ambient temperature	$T_{amb}$	-25 to +75	°C
Storage temperature	$T_{stg}$	-50 to +125	°C
Power dissipation $T_{amb} = 60^\circ\text{C}$	$P_{tot}$	1	W

## Thermal Resistance

Parameters	Symbol	Value	Unit
Junction ambient SO28	$R_{thJA}$	120	K/W

## Electrical Characteristics

Test conditions (unless otherwise specified):  $V_{Batt} = V_{CC} = 3.6\text{ V}$ ,  $T_{amb} = +25^{\circ}\text{C}$

Parameters	Test Conditions	Symbol	Min.	Typ.	Max.	Unit	Fig.	
<b>Current consumption</b>								
ERX2	ELNA	ERXHF	ERX1	ERXO	EEA	EDEE	ETX	EPREE
0	0	0	0	0	0	0	0	0
Operating voltage range			3.1	3.6	4.7	V		
Inactive mode	$V_{Batt} = 2.9\text{ V}$		30	60	80	$\mu\text{A}$		
Standby mode				0.3	0.5	$\text{mA}$		
RX waiting for RSSI	ERXHF = 1		1.0	1.6	2.4	$\text{mA}$		
RX demodulating MODEM-signal	ERXHF = ERX1 = 1		1.7	2.6	3.7	$\text{mA}$		
Operating current, RX and TX completely active	ERX2 = ELNA = ERXHF = ERX1 = ERXO = EEA = EDEE = GDEM = ETX = 1			7	11.5	$\text{mA}$		
Input resistance			2	3	4	$\text{k}\Omega$	3	
Input capacitance				3		$\text{pF}$	3	
Output impedance			1.2	1.5	1.8	$\text{k}\Omega$	3	
Gain GVMIX	Input level $7\text{ mV}_{\text{rms}}$	$G_{\text{MIX}}$	13	15	17	$\text{dB}$	3	
Input compression point			-17			$\text{dBm}$	3	
Third-order input intercept point			-9			$\text{dBm}$	3	
Carrier breakthrough from internal LO (11.15 MHz) to IF output					300	$\mu\text{V}_{\text{rms}}$	3	
Carrier breakthrough from internal LO (11.15 MHz) to RF input					10	$\mu\text{V}$	3	
<b>Receiver</b>								
<b>IF mixer, <math>f = 10.7\text{ MHz}</math></b>								
<b>IF amplifier: RSSI</b>								
Input resistance			1.6	2	2.5	$\text{k}\Omega$	4	
RSSI sensitivity	$V_{\text{IF}} = 0\ \mu\text{V}_{\text{rms}}$ starting from 0 increase RSSI level until mean of sampled signal at DACO is $\leq 0.2$ RSSI level = CON0  $V_{\text{IF}} = 6\ \mu\text{V}_{\text{rms}}$ , $F = 450\text{ kHz}$  increase RSSI level again until mean of sampled signal at DACO is $\leq 0.2$ . RSSI level = CON1 RSSI sensitivity = CON1-CON0		4				4	
RSSI input voltage dynamic range				65		$\text{dB}$	4	
RSSI level number of steps *)				127			4	
RSSI level step-size in the logarithmic region				0.46		$\text{dB}$	4	

## \*) RSSI Level Programming (Typical Values)

Input Voltage $V_{IF}$ ( $\mu V_{rms}$ )	RSSI Level (Decimal)
0	8
6	15
10	23
100	67
1000	114
10000	

Parameters	Test Conditions	Symbol	Min.	Typ.	Max.	Unit	Fig.	
<b>RF demodulator</b> $f_{IF} = 450$ kHz, $f_{mod} = 1$ kHz, $V_{IF} = 500$ $\mu V_{rms}$								
BSCR	EDEE	GRX0	GRX1	GRX2	GRX3	ERX1	ERX0	
1	0	1	1	1	0	1	1	
Recovered audio (peak-to-peak)	GDEM = 0, $\Delta f_{FM} = 2.5$ kHz GDEM = 1, $\Delta f_{FM} = 5$ kHz			0.4 0.4	0.8 0.8	1.6 1.6	V V	5
Recovered audio output voltage drop	$V_{Batt} = 3.2$ V to 4.7 V			-3			dB	5
AM rejection ratio	30% AM				35		dB	5
<b>RX audio, GDEM = 0</b>								
Change of RX0 signal deemphasis bypass	EDEE = 0; 1			-0.5	0	0.5	dB	5
Gain adjust range					15		dB	5
Gain adjust step				0.8	1	1.2	dB	5
Output signal vs. frequency relative to 1 kHz (0 dB) deemphasis bypassed	100 Hz 300 Hz 1800 Hz 3400 Hz 4350 Hz			-8.0 -2.2 -1.4 -0.8 -80	-7.0 -1.2 -0.4 0.2 -60	-6.0 -0.2 0.6 1.2 -55	dB	5
Output signal versus frequency relative to 1 kHz (0 dB) deemphasis enable EDEE = 1	100 Hz 300 Hz 1800 Hz 3400 Hz 4350 Hz			-1.6 3.2 -5.7 -10.5 -80	-0.6 4.2 -4.7 -9.5 -60	0.4 5.2 -3.7 -8.5 -55	dB	5
Total harmonic distortion	$\Delta FM = 250$ Hz $\Delta FM = 2.50$ kHz					2.5 2.5	%	5
Audio mute	$\Delta FM = 2.5$ kHz ERX0 = 0 ERX1 = 0 ERX2 = 0			65			dB	5
Output impedance						100	$\Omega$	5

Parameters	Test Conditions	Symbol	Min.	Typ.	Max.	Unit	Fig.
<b>Expander</b>							
EEA 1	GEA0 0	GEA1 0	GEA2 0	GEA3 1	GEA4 1		
Gain reference level	$V_{EXIN} = -10 \text{ dBV}_{\text{rms}}$	G <sub>OREC</sub>	11	13	15	dB	6
Change of gain when expander is bypassed	BCOMP = 1		-0.5		0.5	dB	6
Gain tracking	$V_{EXIN} = -20 \text{ dBV}_{\text{rms}}$ $V_{EXIN} = -30 \text{ dBV}_{\text{rms}}$ $V_{EXIN} = -35 \text{ dBV}_{\text{rms}}$ $V_{EXIN} = -40 \text{ dBV}_{\text{rms}}$		-21 -41 -53	-50 -60	-19 -39 -47	dB	6
Input impedance			9.5		14.5	k $\Omega$	6
Gain change versus supply voltage	$V_{\text{Batt}} = 3.2 \text{ V to } 4.7 \text{ V}$		-0.5		0.5	dB	6
Attack time	$V_{EXIN} = \text{step}$ $-20 \text{ dBV}_{\text{rms}} \rightarrow -14 \text{ dBV}_{\text{rms}}$ , measure time after step when output voltage is 0.75 times the final value	$t_r$		16		ms	6
Release time	$V_{EXIN} = \text{step}$ $14 \text{ dBV}_{\text{rms}} \rightarrow -20 \text{ dBV}_{\text{rms}}$ , measure time after step when output voltage is 1.5 times the final value	$t_f$		16		ms	6
<b>Earpiece amplifier</b> BCOMP = 1, EEA = 1, $V_{EXIN} = 100 \text{ mV}_{\text{rms}}$							
Maximum gain	GEA0 GEA1 GEA2 GEA3 1 1 1 1 GEA4 = 1		19	20	21	dB	6
Medium gain	GEA0 GEA1 GEA2 GEA3 0 0 0 0 GEA4 = 1		4	5	6	dB	6
Minimum gain	GEA0 GEA1 GEA2 GEA3 0 0 0 0 GEA4 = 0		-12	-11	-10	dB	6
Gain change vs. supply voltage	$V_{\text{Batt}} = 3.2 \text{ V to } 4.7 \text{ V}$		-0.2		0.2	dB	6
Gain adjust range				31		dB	6
Gain adjust step			0.8	1	1.2	dB	6
Output impedance				10	30	$\Omega$	6
Distortion		$d_t$			1	%	6
Output offset voltage	$V_{EXIN} = 0 \text{ mV}_{\text{rms}}$		-200		200	mV	6
Output voltage swing (peak-to-peak)	Increase $V_{EXIN}$ until distortion (RECO1/ RECO2) is 5%	$V_{pp}$	4.8	5.0		V	6

Parameters	Test Conditions	Symbol	Min.	Typ.	Max.	Unit	Fig.	
<b>Low-frequency transmitter</b>								
GMIC	EPREE	BXCR	G1TX	G2TX	BCOMP	ETX		
1	1	1	1000	1000	1	1		
<b>Microphone amplifier</b> $V_{MIC} = 10 \text{ mV}_{\text{rms}}$ , $f_{IN} = 1 \text{ kHz}$								
Gain	High gain: GMIC = 1 Low gain: GMIC = 0			31 23	32 24	33 25	dB	7
Gain change vs. supply voltage	$V_{Batt} = 3.2 \text{ V to } 4.7 \text{ V}$			-0.2	0	0.2	dB	7
Differential input impedance				41	75	103	k $\Omega$	7
Output impedance					10	35	$\Omega$	7
Distortion	$V_{MIC} = 10 \text{ mV}_{\text{rms}}$		$d_t$			1	%	7
Output noise (psophometrically weighted)	$V_{MIC} = 0 \text{ V}_{\text{rms}}$ high gain (inputs closed across 200 $\Omega$ )					50	$\mu\text{V}_{\text{rmsp}}$	7
<b>TX audio</b> $V_{COIN} = -20 \text{ dBV}_{\text{rms}}$								
Gain	GTX (TXO, COIN)			2.5	5.5	8.5	dB	8
Change of gain TXO	EPREE = 0			-0.5	0	0.5	dB	8
Gain between 3.2 and 4.7 V				-1	0	-1	dB	8
TX gain adjust range adj. 1					15		dB	8
TX gain adjust step adj. 1				0.8	1	1.2	dB	8
LIM gain adjust range adj. 2					15		dB	8
LIM gain adjust range adj.2				0.8	1	1.2	dB	8
TX gain versus frequency (pre-emphasis bypassed) relative to 1 kHz reference level 0 dB	100 Hz 300 Hz 1800 Hz 3400 Hz 4350 Hz			-1.3 -1.2 -0.8 -1.1 -20.0	-0.3 -0.2 0.2 -0.1 -24.0	0.7 0.8 1.2 0.7 -28.0	dB	8
Gain versus frequency with pre-emphasis relative to 1 kHz reference level 0 dB	100 Hz 300 Hz 1800 Hz 3400 Hz 4350 Hz			-7.5 -6.5 3.3 6.9 -15.0	-6.5 -5.8 4.3 7.0 -14.0	-5.5 -4.5 5.3 8.9 -13.0	dB	8
Total band ripple	$V_{Batt} = 3.2 \text{ V to } 4.7 \text{ V}$ $V_{COIN} = -20 \text{ dBV}$					2	dB	8
<b>Limiter</b>								
Output voltage (peak-to-peak)	Increase $V_{COIN}$ until $d = 5\%$ at TX0 then measure VTX0			1.2	1.68	2.3	V	
Mute	ETX = 0, $V_{COIN} = -10 \text{ dBV}$ attenuation at TX0 output			65			dB	
Output impedance				7	10	14	k $\Omega$	

Parameters	Test Conditions	Symbol	Min.	Typ.	Max.	Unit	Fig.			
<b>Componder / compressor</b>										
BSCR	EPREE	G2TX0	G2TX1	G2TX2	G2TX3	ETX	G1TX0	G2TX1	G1TX2	G1TX3
1	0	0	1	0	1	1	0	0	1	0
Input impedance	BCOMP = 1			9	14	22	kΩ	8		
Gain reference level G0TX	V <sub>COIN</sub> = -10 dBV <sub>rms</sub>		G <sub>0TX</sub>	1	5.5	10	dB	8		
Gain change when compressor is bypassed	V <sub>COIN</sub> = -10 dBV <sub>rms</sub> BCOMP = 1			0.5		0.5	dB	8		
Gain tracking	V <sub>COIN</sub> = -30 dBV <sub>rms</sub> V <sub>COIN</sub> = -50 dBV <sub>rms</sub> V <sub>COIN</sub> = -60 dBV <sub>rms</sub> V <sub>COIN</sub> = -70 dBV <sub>rms</sub>			-11 -21 -22		-9 -19 -28	dB	8		
Attack time	V <sub>COIN</sub> = step -30 dBV <sub>rms</sub> → -18 dBV <sub>rms</sub> measure time after step when output voltage is 1.5 times the final value		t <sub>r</sub>		3.5		ms	8		
Release time	V <sub>COIN</sub> = step -18 dBV <sub>rms</sub> → -30 dBV <sub>rms</sub> measure time after step when output voltage is 0.75 times the final value		t <sub>r</sub>		14.4		ms	8		
<b>Scrambler</b>										
EPREE	BSCR	BCOMP								
0	0	1								
Conversion gain versus frequency f <sub>IN</sub> (1 kHz) reference level 0 dB	f <sub>IN</sub> =100Hz, f <sub>OUT</sub> =4255Hz f <sub>IN</sub> =300Hz, f <sub>OUT</sub> =4055Hz f <sub>IN</sub> =700Hz, f <sub>OUT</sub> =3655Hz f <sub>IN</sub> =1800Hz, f <sub>OUT</sub> =2555Hz f <sub>IN</sub> =2600Hz, f <sub>OUT</sub> =1755Hz f <sub>IN</sub> =3400Hz, f <sub>OUT</sub> =955Hz f <sub>IN</sub> =3600Hz, f <sub>OUT</sub> =755Hz f <sub>IN</sub> =1000Hz, f <sub>OUT</sub> =3355Hz			-4.5 -2.3 -0.9 -1.1 -1.1 -2.5 -4.9 -1	-3.5 -1.3 0.1 -0.1 -0.1 -1.5 -3.9 0	-2.5 -0.3 1.1 0.9 0.9 -0.5 -2.8 1	dB	9		
Carrier break through	Measure f <sub>OUT</sub> = 4355 kHz				10	20	mV <sub>rms</sub>			
<b>Descrambler</b>										
EDEE	BSCR	BCOMP								
0	0	1								
Conversion gain versus frequency	f <sub>IN</sub> =4255Hz, f <sub>OUT</sub> =100Hz f <sub>IN</sub> =4055Hz, f <sub>OUT</sub> =300Hz f <sub>IN</sub> =3655Hz, f <sub>OUT</sub> =700Hz f <sub>IN</sub> =2555Hz, f <sub>OUT</sub> =1800Hz f <sub>IN</sub> =1755Hz, f <sub>OUT</sub> =2600Hz f <sub>IN</sub> =955Hz, f <sub>OUT</sub> =3400Hz f <sub>IN</sub> =755Hz, f <sub>OUT</sub> =3600Hz f <sub>IN</sub> =3355Hz, f <sub>OUT</sub> =1000Hz			-3.8 -1.6 -0.5 -1.7 -0.7 -1.4 -1.7 -1	-2.6 -0.6 0.5 -0.7 6.3 -0.4 -0.7 0	-1.8 0.1 1.5 0.3 1.3 0.6 0.3 1	dB	9		
Carrier break through	Measure f <sub>OUT</sub> = 4355 kHz				0.1	0.5	mV <sub>rms</sub>			

Parameters	Test Conditions	Symbol	Min.	Typ.	Max.	Unit	Fig.
<b>FSK modem (1200 Bauds)</b>							
FSK-demodulator Input signal discriminator IFIN1-IFIN2—RXDAT  2100 Hz — = 0 1300 Hz — = 1	IFIN = 450 kHz VIFIN = 0.5 mV <sub>rms</sub> df = 2.4 kHz ERX1 = 1 GDEM = 0 (high gain) GRX3 = 1 (+1dB)		1720		1660	Hz Hz	
FSK – modulator TXDAT — TXO Output signal level TXDAT — TXOUT  Signal distortion TXDAT — TXOUT	ETX = 1 EFSK = 1 TXDAT = 0 TXOUT = 2100 Hz TXDAT = 1 TXOUT = 1300 Hz TXDAT = 0 TXOUT = 2100 Hz TXDAT = 1 TXOUT = 1300 Hz		0.87		1.54 1.54 2 2	V <sub>pp</sub> V <sub>pp</sub> % %	
Output signal frequency	TXDAT = 0 TXDAT = 1		2100 1300			Hz	
Output signal – Distortion – Offset level			1.5	2		% V	
<b>Logical part</b>							
Inputs: C, D, TXDAT Low-voltage input High-voltage input Input leakage current (0 < V <sub>I</sub> < V <sub>CC</sub> )			2.5 –1		0.5 1	V V μA μA	
Input LOIN Input leakage current pin XCK (0 < V <sub>I</sub> < V <sub>CC</sub> )			–5		5	μA	
Outputs: DACO, RXDAT Output low Output high	I <sub>ol</sub> = 10 μA I <sub>oh</sub> = –10 μA		0.9 × V <sub>CC</sub>		0.1 × V <sub>CC</sub>		
Serial bus Data set-up time Data hold time Clock low time Clock high time Hold time before transfer condition Data low pulse on transfer condition Data high pulse on transfer condition		t <sub>sud</sub> t <sub>hd</sub> t <sub>cl</sub> t <sub>ch</sub> t <sub>eon</sub>  t <sub>eh</sub> t <sub>eof</sub>	0.1 0 2 2 0.1  0.2 0.2			μs μs μs μs μs  μs μs	12

Parameters	Test Conditions	Symbol	Min.	Typ.	Max.	Unit	Fig.
<b>Battery management</b>							
Max batlow	DA0 to 6 = 1, RBAT = 1		3.8	3.95	4.1	V	
Min batlow over switch	DA0 to 6 = 27 BIN, RBAT = 1		3.05	3.2	3.35	V	
Max bathigh	DA0 to 6 = 1, RBAT = 0		4.85	5.05	5.25	V	
Min bathigh	DA0 to 6 = 0, RBAT = 0		3.93	4.1	4.27	V	
Adjust step			3.5	7.5	11.5	mV	
Max – Min			852.5	952.5	1052.5	mV	
MINBL – SWOFF			100	200	300	mV	
<b>Battery switch</b>							
Off threshold	DA0 to 6 = 1, RBAT = 1		2.9	3.0	3.1	V	
On threshold	DA0 to 6 = 27 BIN, RBAT = 1		3.15	3.25	3.35	V	
Hysteresis			220	250	280	mV	
Switch $R_{on}$	DA0 to 6 = 0, RBAT = 0			35	50	$\Omega$	

- Max batlow** : MAXBL (battery voltage when all DAC bits are high, low range)  
**Min batlow** : MINBL (battery voltage when DAC bits are 0011011, low range)  
**Max bathigh** : MAXBH (battery voltage when all DAC bits are high, high range)  
**Min bathigh** : MINBH (battery voltage when all DAC bits are low, high range)  
**Adjust step** : Adjust step  
**Max – Min** : MAXBH – MINBH  
**MINBL – SWOFF** : MINBL – SWOFF  
**Off threshold** : SWOFF (off threshold of the battery switch)  
**On threshold** : SWON (on threshold of the battery switch)  
**Hysteresis** : SWON – SWOFF  
**Switch  $R_{on}$**  : Switch  $R_{on}$  (resistance of the switch transistor, when switch is “ON”)

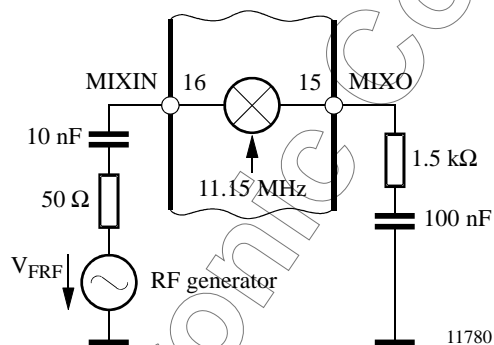

Figure 3. Test circuit

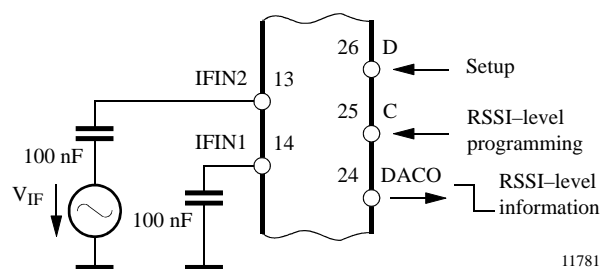

Figure 4.

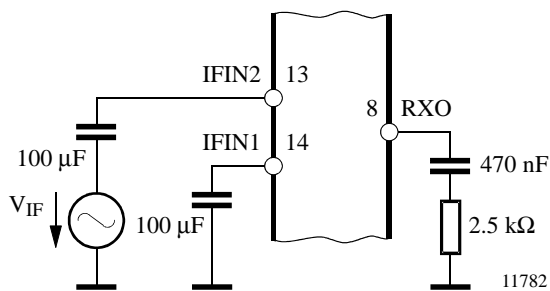

Figure 5.

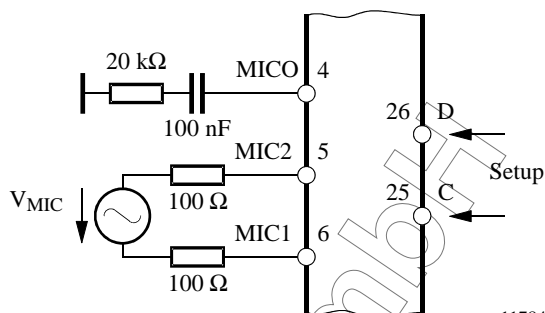

Figure 7.

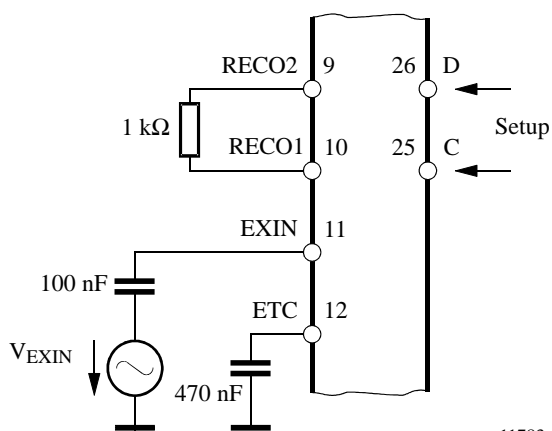

Figure 6.

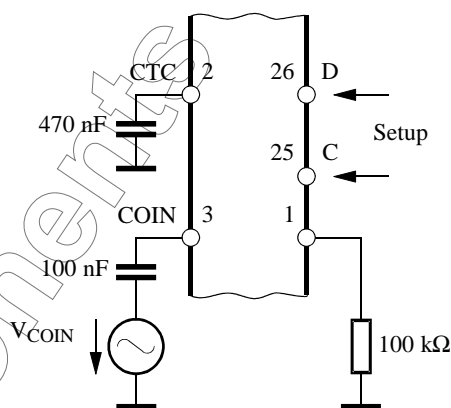

Figure 8.

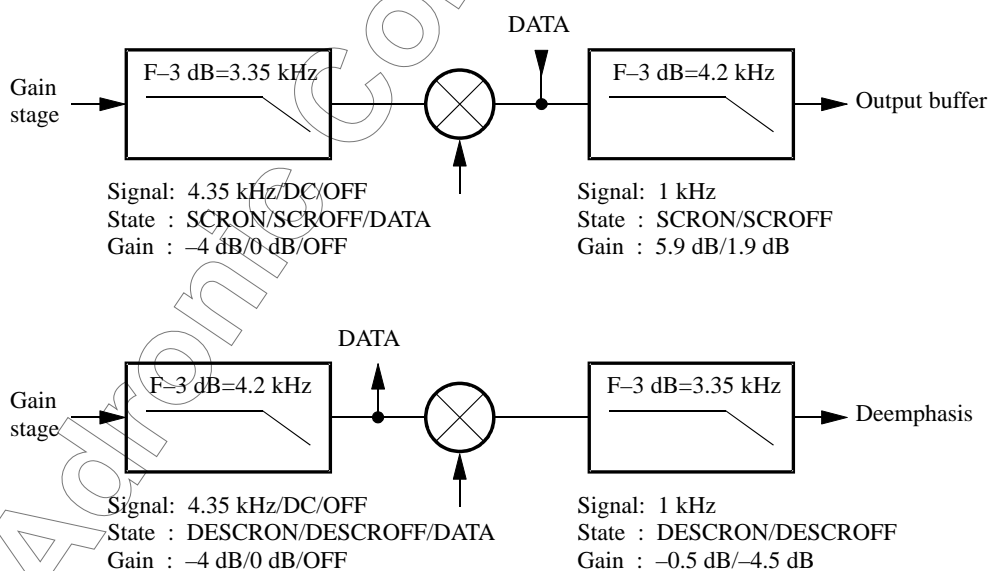

Figure 9.

**Serial Bus Interface**

The circuit is remoted by an external microcontroller trough the serial bus.

The data is an 12-bit word:

A3 – A0: address of the destination register (0 to 15)

D7 – D0: contents of register

The data line must be stable when the clock is high and data must be shifted serially.

After 12 clock periods, the transfer to the destination register is generated (internally) by a low to high transition of the data line when the clock is high.

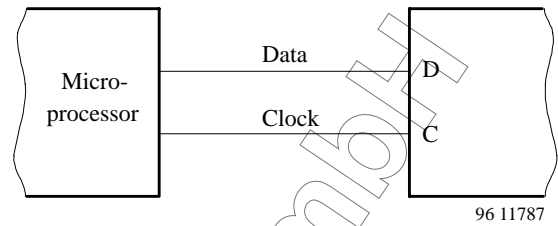

Figure 10.

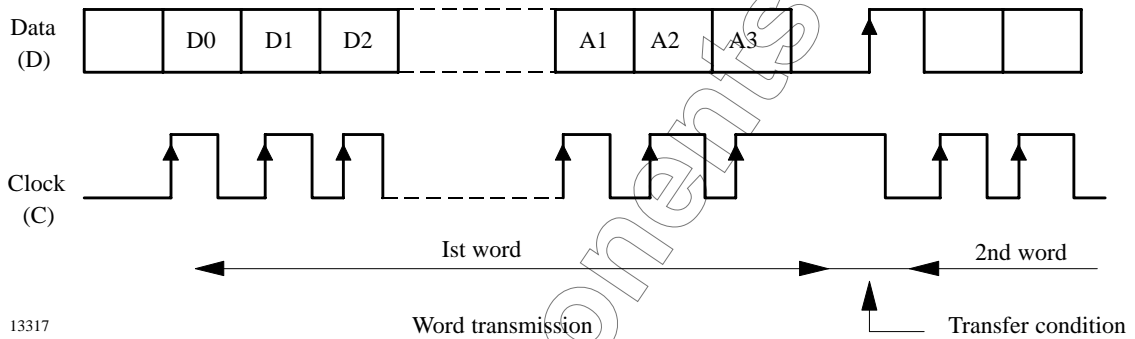

Figure 11. Serial bus transmission

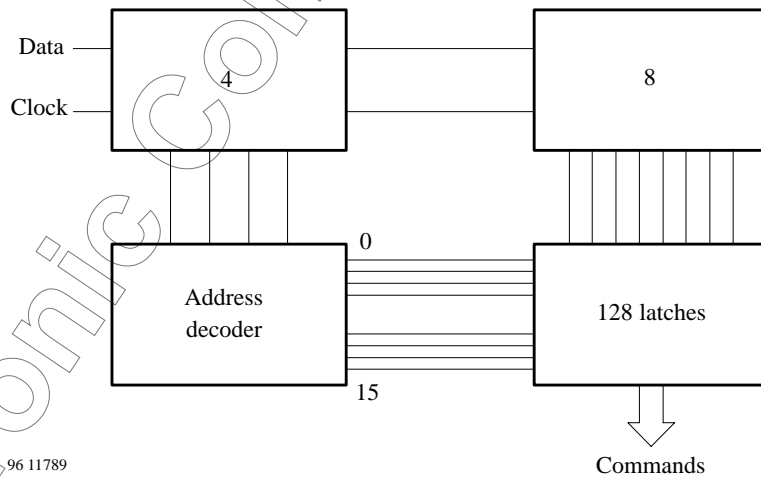

Figure 12.

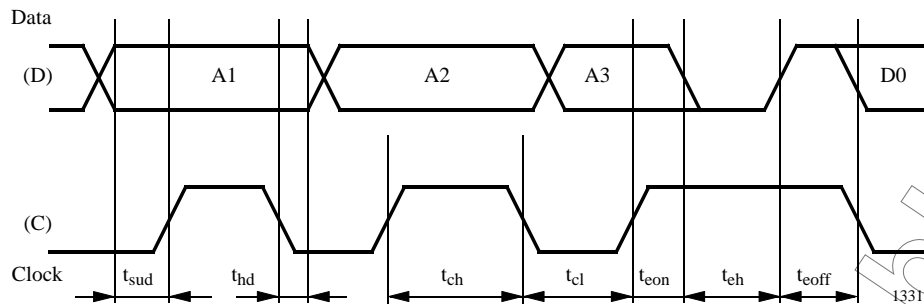

Figure 13.

## Content of Internal Registers

The register have the following structure:

D7	D6	D5	D4	D3	D2	D1	D0
----	----	----	----	----	----	----	----

R0: Reference for D/A converter

MUXDA	DA6	DA5	DA4	DA3	DA2	DA1	DA0
-------	-----	-----	-----	-----	-----	-----	-----

MUXDA: D/A multiplexing

DA(6:0): Reference voltage D/A

R1: Gain adjustment RECLF

GEA3	GEA2	GEA1	GEA0	GRX3	GRX2	GRX1	GRX0
------	------	------	------	------	------	------	------

GEA(3:0): Gain earpiece amplifier (see also R5)

GRX(3:0): Gain adjustment RX

R2: Gain adjustment TRANLF

G2TX3	G2TX2	G2TX1	G2TX0	G1TX3	G1TX2	G1TX1	G1TX0
-------	-------	-------	-------	-------	-------	-------	-------

G2TX(3:0): Gain adjustment TX after limiter

G1TX(3:0): Gain adjustment TX

R3: Enable functions receive

GDEM	EDDE	EEA	ERXO	ERX1	ERXHF	free	ERX2
------	------	-----	------	------	-------	------	------

GDEM: Gain demodulator

EDDE: Enable deemphasis (disables bypass)

EEA: Enable earpiece amplifier

ERXO: Enable RXO output

ERXHF: Enable mixer and IF amplifier

ERX(1:2): Enable parts of RXLF

R4: Enable functions transmit

SRSSI	RBAT	BCOMP	BSCR	GMIC	EFSK	EPREE	ETX
-------	------	-------	------	------	------	-------	-----

SRSSI: RSSI sample hold  
 RBAT: Battery detection high/low range  
 BCOMP: Bypass compressor and expander  
 BSCR: Bypass scrambler and descrambler  
 GMIC: Gain of microphone preamplifier  
 EFSK: Enable modulator of FSK modem  
 EPREE: Enable pre-emphasis (disables bypass)  
 ETX: Enable TX low frequency part

R5:

free	free	free	free	free	free	GEA4	EXTLO
------	------	------	------	------	------	------	-------

GEA4: Gain earpiece amplifier MSB (see also R1)  
 EXTLO: Select input mixer

R6 – R15: reserved for U3500BM

## Example of Mode Setting Using Enable Bits and Battery Switch

U3501BM, see figure 14

	Active Mode (Transmission)	Active Mode (PLL Convergence Waiting)	Receive Mode (Only Data)	Receive Mode (RX Waiting)	Standby Mode (ex: Battery Low)	Inactive Mode (Switch Off)
Transmitter *MC	X					
*ETX, ERX2, ERXO	X	X				
ERX1	X	X	X			
ERXHF, ELNA *EVCO3 RSSI/Battery Management (MUXDA)	X	X	X	X		
MC + LOGIC PART (Enabled when $V_{Batt} > 3.2V$ )	X	X	X	X	X	
Switch Comparator of VCC (Always Enabled)	X	X	X	X	X	X

MC = Microcontroller, \*MC = Link directly from microcontroller

## Application Circuit

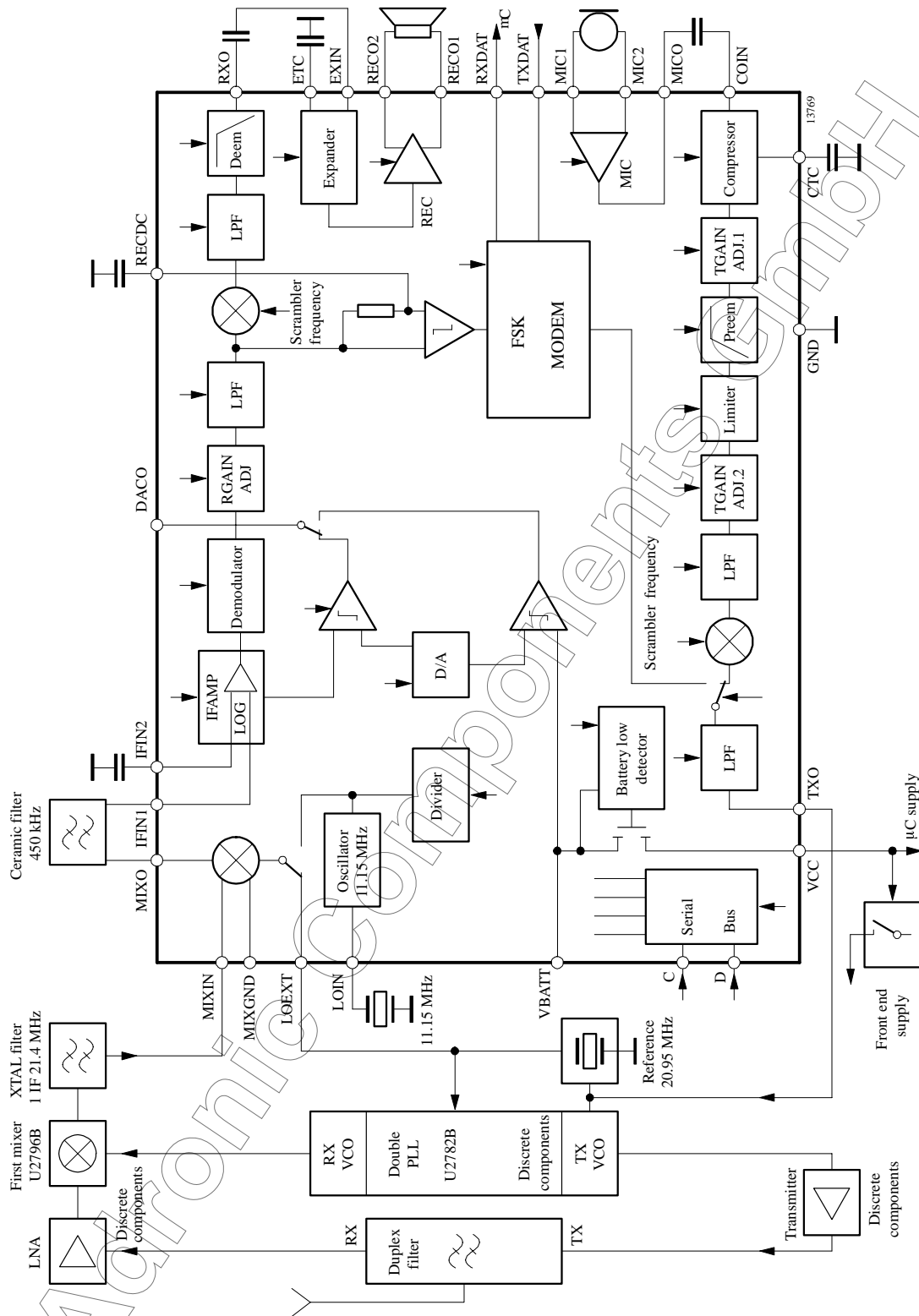
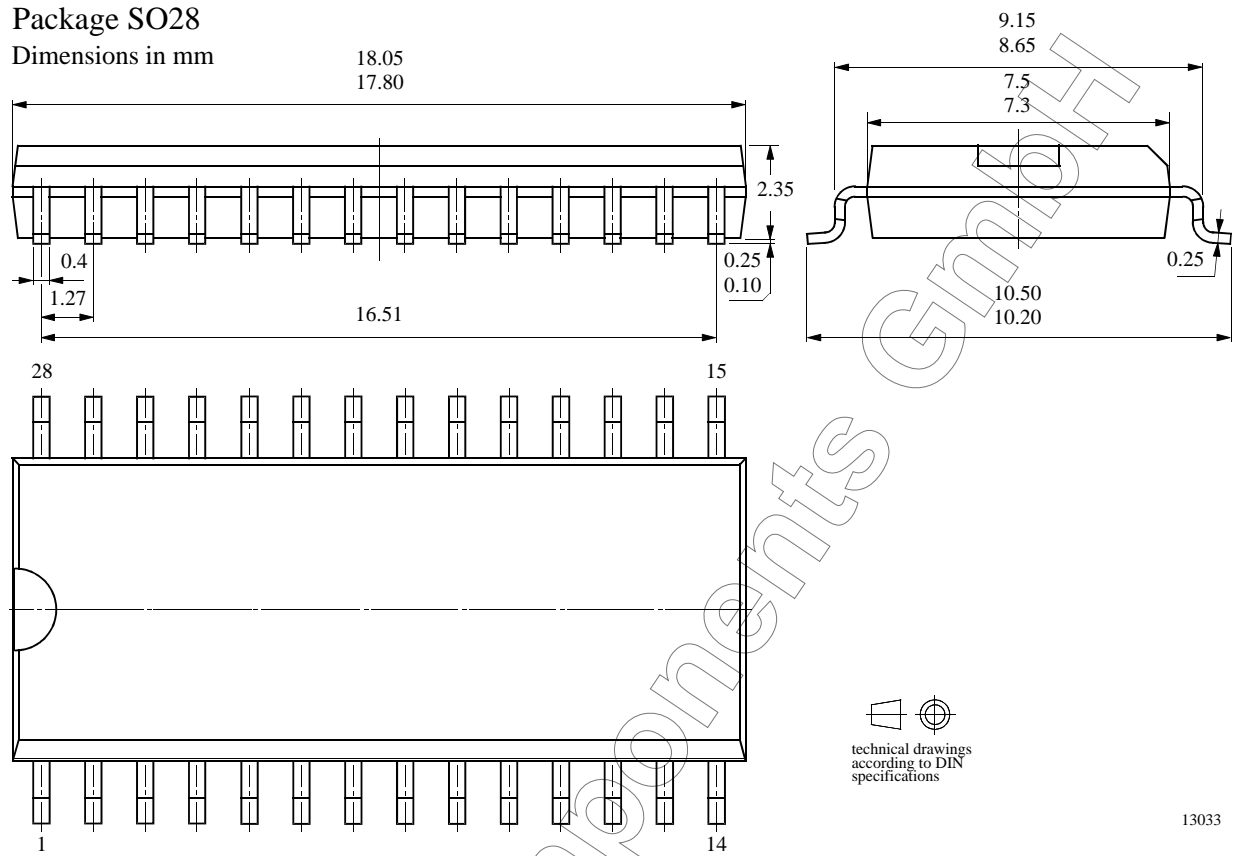

Figure 14. Application circuit

**Package Information**

Package SO28

Dimensions in mm



technical drawings  
according to DIN  
specifications

13033

## Ozone Depleting Substances Policy Statement

It is the policy of **TEMIC Semiconductor GmbH** to

1. Meet all present and future national and international statutory requirements.
2. Regularly and continuously improve the performance of our products, processes, distribution and operating systems with respect to their impact on the health and safety of our employees and the public, as well as their impact on the environment.

It is particular concern to control or eliminate releases of those substances into the atmosphere which are known as ozone depleting substances (ODSs).

The Montreal Protocol (1987) and its London Amendments (1990) intend to severely restrict the use of ODSs and forbid their use within the next ten years. Various national and international initiatives are pressing for an earlier ban on these substances.

**TEMIC Semiconductor GmbH** has been able to use its policy of continuous improvements to eliminate the use of ODSs listed in the following documents.

1. Annex A, B and list of transitional substances of the Montreal Protocol and the London Amendments respectively
2. Class I and II ozone depleting substances in the Clean Air Act Amendments of 1990 by the Environmental Protection Agency (EPA) in the USA
3. Council Decision 88/540/EEC and 91/690/EEC Annex A, B and C (transitional substances) respectively.

**TEMIC Semiconductor GmbH** can certify that our semiconductors are not manufactured with ozone depleting substances and do not contain such substances.

**We reserve the right to make changes to improve technical design and may do so without further notice.**

Parameters can vary in different applications. All operating parameters must be validated for each customer application by the customer. Should the buyer use TEMIC products for any unintended or unauthorized application, the buyer shall indemnify TEMIC against all claims, costs, damages, and expenses, arising out of, directly or indirectly, any claim of personal damage, injury or death associated with such unintended or unauthorized use.

TEMIC Semiconductor GmbH, P.O.B. 3535, D-74025 Heilbronn, Germany  
Telephone: 49 (0)7131 67 2594, Fax number: 49 (0)7131 67 2423