

Logarithmic AM Demodulator / RSSI

Description

The U4314B is a monolithic Integrated Circuit in bipolar technology for low current super-heterodyne receivers. It can be used as a logarithmic **R**eceived **S**ignal **S**trength **I**ndicator (RSSI) or as a logarithmic AM demodulator. Its bandwidth is optimized for intermediate frequencies of 9 to 10.7 MHz (see figure 9).

Its low current consumption and wide power supply voltage range make this IC predestined to add a temperature compensated field strength indication to new or existing receiver or instrumentation designs, missing such a function.

It can also be used as a logarithmic AM demodulator. Its dynamic range in excess of 60 dB (see figure 10) supports a receiver design without the need of an automatic gain control (AGC). The usable data rate is up to several

hundred kBauds. Typical applications are keyless entry and alarm systems for cars and buildings.

The U4314B supports a superhet receiver design with less than 1 mA total current consumption, which is a peremptory requirement claimed by international car manufacturers. As this IC needs only 3.0 V supply voltage, the front end may be a stacked design in order to reach this extremely low total receiver current consumption.

A proposal for a discrete RF front end with a surface acoustic wave (SAW) resonator based local oscillator special low current UHF-transistors like S822T or S852T can be found in the application notes ANT012 and ANT013.

Features

- Logarithmic RSSI / AM demodulator output
- Sensitive IF-amplifier for 10.7 MHz operating frequency
- Usable for ASK data systems up to several hundred kBauds
- Extreme low current consumption typically 0.8 mA
- Wide power supply voltage range 3 to 12 V
- Temperature compensated reference voltage of 2.4 V externally available
- Only one additional part (capacitor) necessary
- ESD hardened

Block Diagram

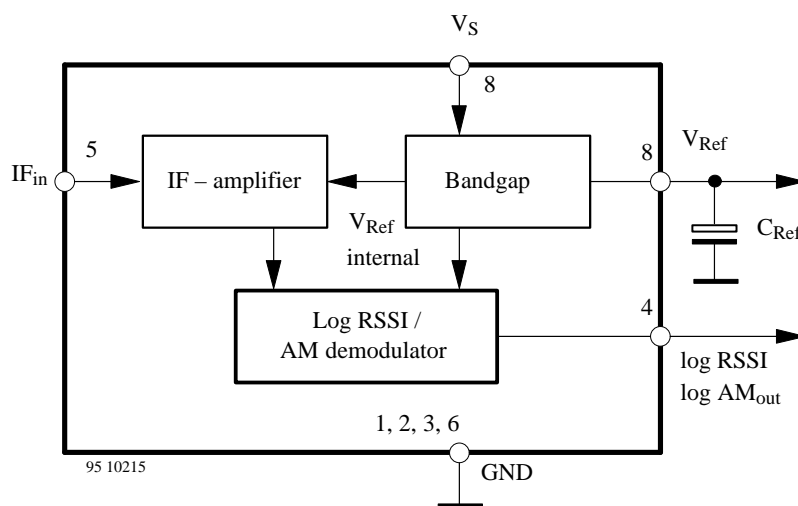
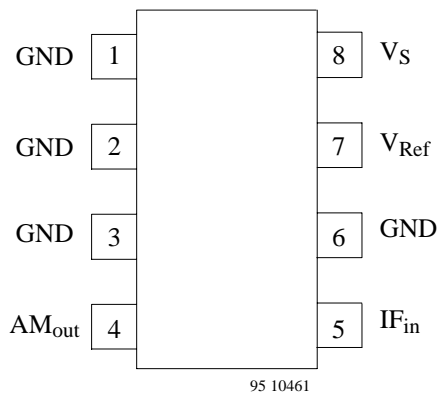

Figure 1. Block diagram

Ordering Information

Extended Type Number	Package	Remarks
U4314B-AFP	SO8	

Pin Description



Pin	Symbol	Function
1, 2, 3, 6	GND	Ground
4	AM _{out}	RSSI / AM current output
5	IF _{in}	IF input
7	V _{Ref}	Reference voltage
8	V _S	Supply voltage

Figure 2. Pin description

Absolute Maximum Ratings

Parameters	Symbol	Value	Unit
Supply voltage	V _S	13	V
Power dissipation at T _{amb} = 85°C	P _{tot}	220	mW
Junction temperature	T _j	125	°C
Ambient temperature	T _{amb}	-40 to +85	°C
Storage temperature	T _{stg}	-55 to +125	°C

Thermal Resistance

Parameters	Symbol	Value	Unit
Junction ambient	R _{thJA}	180	K/W

Electrical Characteristics

V_S = 5 V, T_{amb} = 25°C, f_{in} = 10.7 MHz unless otherwise specified. Test circuit see figure 8. IF voltage levels are referred to the input of the matching network and therefore approximately 5.6 dB higher than referred to Pin 5.

Parameters	Test Conditions / Pins	Symbol	Min.	Typ.	Max.	Unit
Characteristics						
Supply voltage range	Pin 8	V _S	3		12	V
Supply current	Pin 8	I _S		0.8	1.25	mA
Bandgap						
Regulated voltage (without external load)	Pin 7	V _{ref}	2.3	2.4	2.5	V
Source resistance	Pin 7	R _{ref}		2	5	Ω
Output current	Pin 7	I _{ref}			5	mA
External capacitor	Pin 7	C _{ref}		4.7		μF
Power supply rejection ratio	f = 50 Hz Pin 7	psrr		60		dB
IF amplifier						
Input resistance	Pin 5	R _{in}	200	330	650	Ω
Input capacitance	Pin 5	C _{in}		5		pF
-3 dB limiting point	Pin 5	V _{IFin}	26	36	46	dBμV
Maximum AM input voltage	Pin 5	V _{IFinmax}		96		dBμV
AM _{out} quiescent current	R _{load} = 10 kΩ Pin 4	I _{AMout}	10	22	38	μA
Maximum AM _{out} current	V _{IFin} = 96 dBμV, R _{load} = 10 kΩ Pin 4	I _{AMoutmax}	75	105	125	μA

Circuit Description

General functions

The integrated circuit U4314B includes the following functions: IF-amplifier, logarithmic RSSI / AM demodulator and voltage-regulator.

The 10.7 MHz IF-signal from the front end passes the integrated IF-amplifier which operates to a logarithmic RSSI/AM-demodulator. A logarithmic demodulator was implemented to avoid settling time problems effected by use of an AGC. The temperature compensated reference voltage of 2.4 V is externally available. The value of the external blocking capacitor can be adapted to the maximum expected load current out of the voltage regulator. The total supply current is typically 0.8 mA plus this load current.

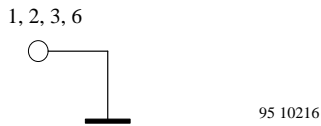

Figure 3. Pin 1, 2, 3, 6 GND

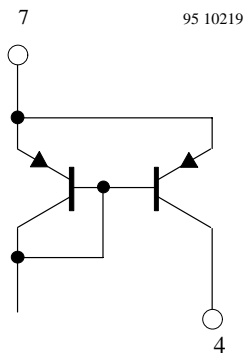

Figure 4. Pin 4 AM_{out}

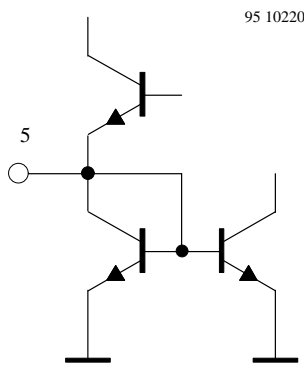

Figure 5. Pin 5 IF_{in}

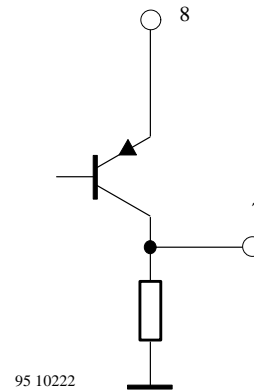

Figure 6. Pin 7 V_{Ref}

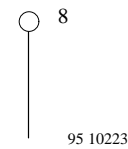

Figure 7. Pin 8 V_S

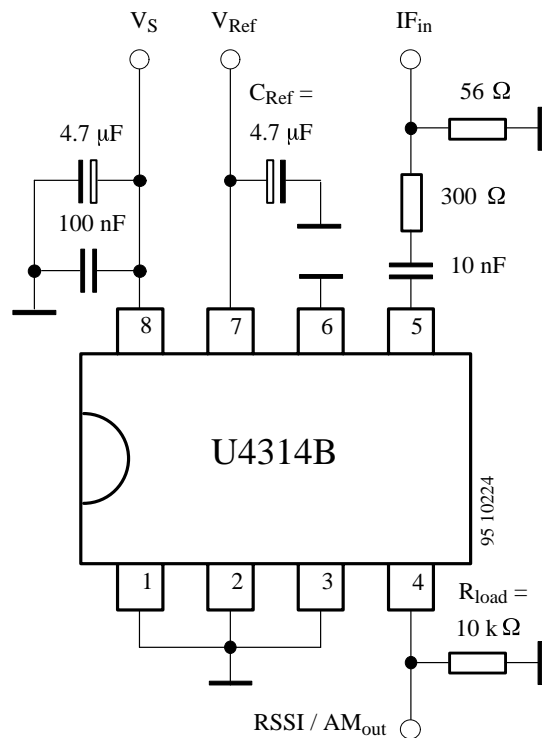
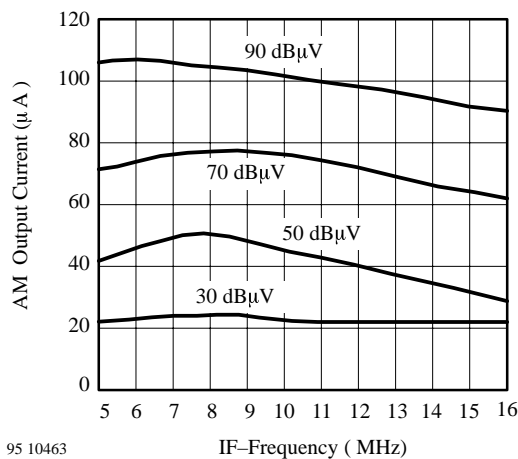
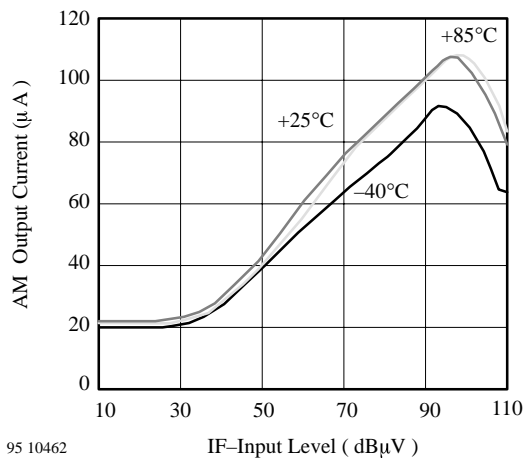

Figure 8. Test circuit



95 10463

Figure 9. IF-Frequency response



95 10462

Figure 10. AM-demodulator characteristic ($f_{in} = 10.7$ MHz)

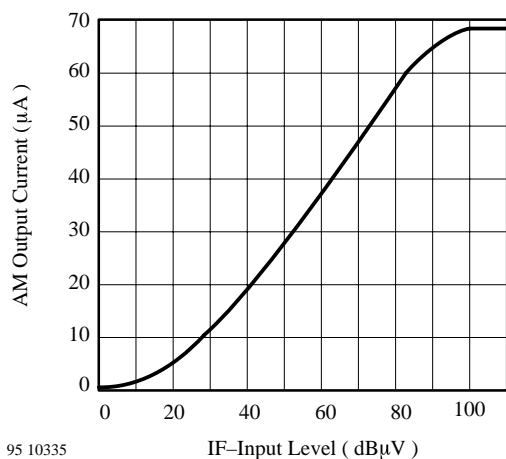

95 10335

Figure 11. $I_{AM_{out}}$ of U4314B in the application circuit of figure 12 ($f_{in} = 107$ MHz)

The following circuit is a mere proposal, how to improve sensitivity and extend the dynamic range of U4314B to more than 90 dB. However in most applications the basic dynamic range of more than 60 dB is sufficient. TEMIC Semiconductor GmbH makes no representation that the use of this circuit will not reframe on existing or future patents and no responsibility for the use of the information contained herein is assumed. This circuit is neither optimized concerning tolerances of the components nor tested versus temperature. It should work with a single supply voltage of 3 to 12 V. A npn transistor array CA3045 or similar is used. At least four transistors are needed to realize two current mirrors and the fifth acts as a preamplifier. The variable resistor P_1 is used to compensate the quiescent current of the logarithmic demodulator output and may be replaced by a fixed resistor (typ. 3.3 kΩ). The total supply current depends on the IF-input level and varies between 2 and 7 mA. It is mainly determined by the current through the PIN diode. We recommend to use the BA679S PIN diode available from TEMIC Semiconductor GmbH. The input impedance of this application circuit is approximately $1.5 \text{ k}\Omega \parallel 13 \text{ pF}$.

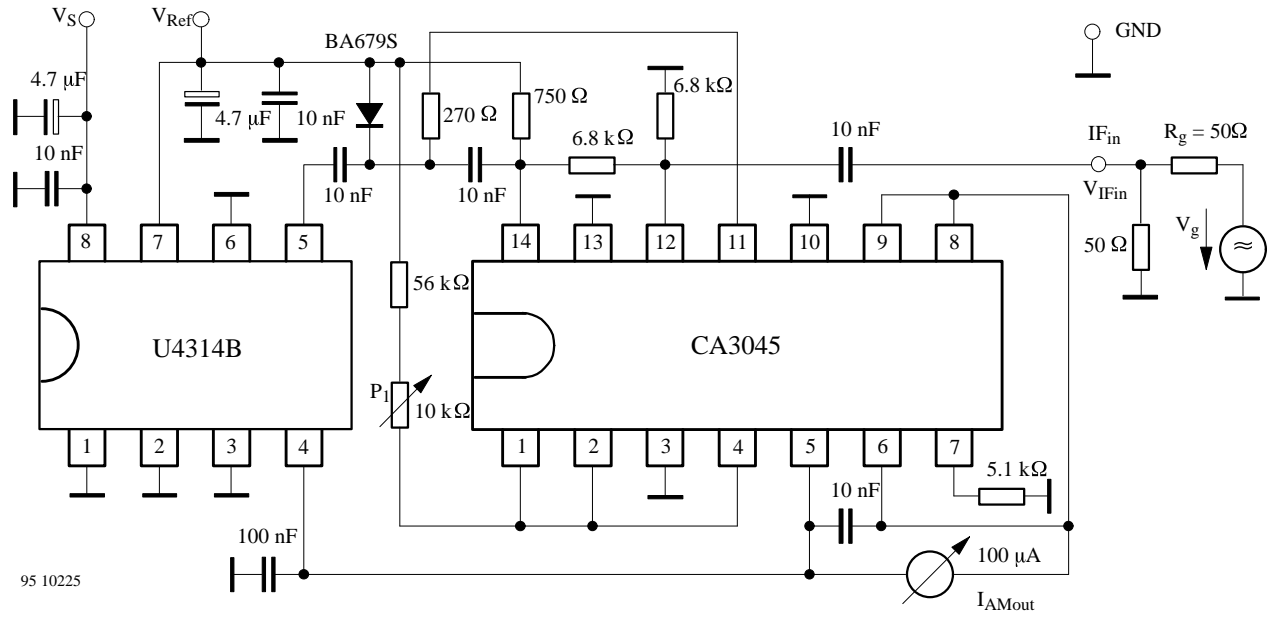
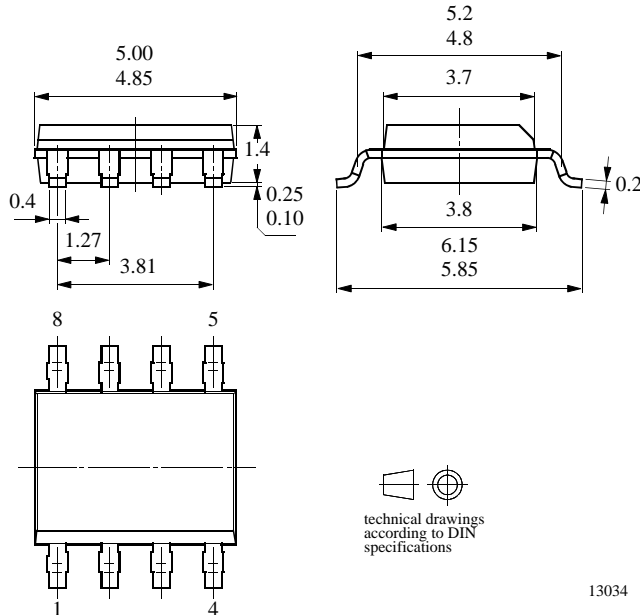

Figure 12. Application circuit with a dynamic range in excess of 90 dB

Dimensions in mm

Package SO8

Dimensions in mm



13034

Ozone Depleting Substances Policy Statement

It is the policy of **TEMIC Semiconductor GmbH** to

1. Meet all present and future national and international statutory requirements.
2. Regularly and continuously improve the performance of our products, processes, distribution and operating systems with respect to their impact on the health and safety of our employees and the public, as well as their impact on the environment.

It is particular concern to control or eliminate releases of those substances into the atmosphere which are known as ozone depleting substances (ODSs).

The Montreal Protocol (1987) and its London Amendments (1990) intend to severely restrict the use of ODSs and forbid their use within the next ten years. Various national and international initiatives are pressing for an earlier ban on these substances.

TEMIC Semiconductor GmbH has been able to use its policy of continuous improvements to eliminate the use of ODSs listed in the following documents.

1. Annex A, B and list of transitional substances of the Montreal Protocol and the London Amendments respectively
2. Class I and II ozone depleting substances in the Clean Air Act Amendments of 1990 by the Environmental Protection Agency (EPA) in the USA
3. Council Decision 88/540/EEC and 91/690/EEC Annex A, B and C (transitional substances) respectively.

TEMIC Semiconductor GmbH can certify that our semiconductors are not manufactured with ozone depleting substances and do not contain such substances.

We reserve the right to make changes to improve technical design and may do so without further notice.

Parameters can vary in different applications. All operating parameters must be validated for each customer application by the customer. Should the buyer use TEMIC products for any unintended or unauthorized application, the buyer shall indemnify TEMIC against all claims, costs, damages, and expenses, arising out of, directly or indirectly, any claim of personal damage, injury or death associated with such unintended or unauthorized use.

TEMIC Semiconductor GmbH, P.O.B. 3535, D-74025 Heilbronn, Germany
Telephone: 49 (0)7131 67 2594, Fax number: 49 (0)7131 67 2423