



# AG603

InGaP HBT Gain Block

The Communications Edge™

Preliminary Product Information

## Product Features

- DC - 2700MHz
- +18.5 dBm P1dB at 900MHz
- +33.5 dBm OIP3 at 900MHz
- 17.6 dB Gain at 900MHz
- Single Voltage Supply
- SOT-89 SMT Package
- Internally matched to 50 Ω

## Product Description

The AG603 is a general-purpose buffer amplifier that offers high dynamic range in a low-cost surface-mount package. At 900 MHz, the AG603 typically provides 17.6 dB of gain, +33.5 dBm Output IP3, and +18.5 dBm P1dB. The device combines dependable performance with consistent quality to maintain MTBF values exceeding 100 years at mounting temperatures of +85°C and is housed in a SOT-89 industry standard SMT package.

The AG603 consists of Darlington pair amplifiers using the high reliability InGaP/GaAs HBT technology process technology and only requires DC-blocking capacitors, a bias resistor, and an inductive RF choke for operation.

The broadband MMIC amplifier can be directly applied to various current and next generation wireless technologies such as GPRS, GSM, CDMA, W-CDMA, and UMTS. In addition, the AG603 will work for other various applications within the DC to 2.7 GHz frequency range such as CATV and fixed wireless.

## Functional Diagram

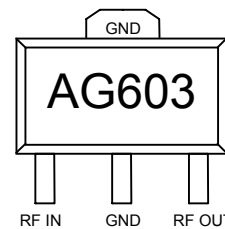

AG603-89

## Specifications

Parameters <sup>1</sup>	Units	Min	Typ	Max
Frequency Range	MHz		DC-2700	
S21 - Gain	dB		17.6	
S11 - Input Return Loss	dB		-15	
S22 - Output Return Loss	dB		-12	
Output P1dB	dBm		+18.5	
Output IP3	dBm		+33.5	
Noise Figure	dB		4.5	
Device Voltage	V		4.9	
Device Current	mA		75	

Test conditions unless otherwise noted

1. T = 25°C, Supply Voltage = +6 V, R<sub>bias</sub> = 10 Ω, Frequency = 900MHz, 50 Ω System.

2. 3OIP measured with two tones at an output power of 0 dBm/tone separated by 10MHz. The suppression on the largest IM3 product is used to calculate the 3OIP using a 2:1 rule.

## Typical Parameters

Parameter <sup>1</sup>	Units	Typical	
Frequency	MHz	900	1900
S21	dB	17.6	16
S11	dB	-20	-25
S22	dB	-15	-15
Output P1dB	dBm	+18.5	+18.1
Output IP3	dBm	+33.5	+32.3
Noise Figure	dB	4.5	4.5
Supply Voltage	V	6	6
Device Current	mA	75	75

1. Data represents typical performance in an application board with T = 25°C, V<sub>s</sub> = +6 V, and R<sub>bias</sub> = 10 Ω in a 50 Ω system.

## Absolute Maximum Ratings

Parameters	Rating
Operating Case Temperature	-40 to +85 °C
Storage Temperature	-40 to +125 °C

Operation of this device above any of these parameters may cause permanent damage

## Application Circuit

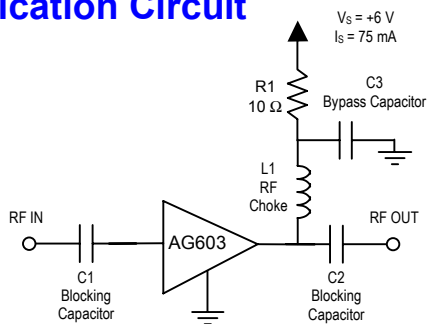

## Ordering Information

Part No.	Description
AG603-89	InGaP HBT Gain Block SOT-89 Style Package (Available in Tape & Reel)
AG603-89PCB	Fully Assembled Application Board

This document contains information on a new product. Specifications and information are subject to change without notice



# AG603

InGaP HBT Gain Block

Preliminary Product Information

## AG603-89 Package Information

### Outline Drawing

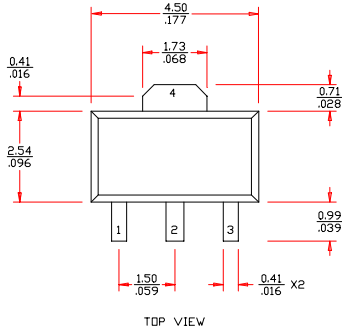

mm  
inch

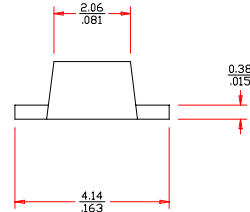
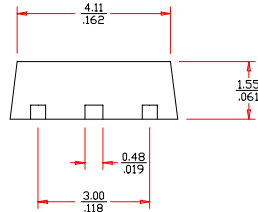

### Land Pattern

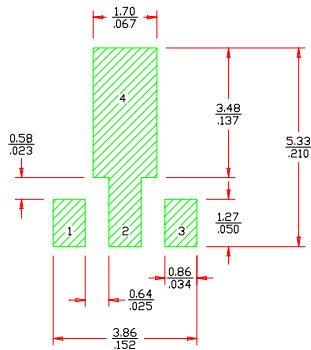

FUNCTION	PIN NO.
INPUT	1
GROUND	2
OUTPUT (BIAS)	3
GROUND	4

### Mounting Configuration

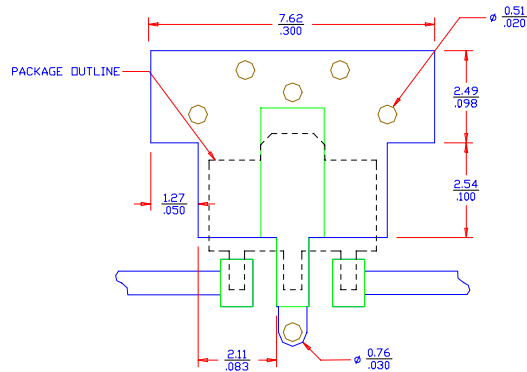

- Notes: 1. Ground vias are critical for thermal and RF grounding considerations.
- 2. Two 2-56 screws with washers should be used for thermal grounding to the main chassis.
- 3. Ground plane on the backside should extend past the holes for the 2-56 screws as a minimum.
- 4. No soldermask should be applied to the backside where heat sink area contacts the main chassis.
- 5. Holes for the 2-56 screws should be plated through.
- 6. Keepout diameter for the 2-56 screw is to allow good thermal contact for the screw and washer.
- 7. Trace width depends on PC board.
- 8. A minimum of 1 oz. / 1 oz. copper should be used.

This document contains information on a new product. Specifications and information are subject to change without notice.