



AH201

Medium Power, High Linearity Amplifier

Product Features

- 400 – 2200 MHz
- +30 dBm P1dB
- +47 dBm Output IP3
- 17 dB Gain @ 900 MHz
- MTBF >100 Years
- Single Positive Supply (9-12V)
- Internally Matched
- 24dBm IS-95 Channel Power @ -45dBc ACPR



Actual Size

Product Description

The AH201 is a 1W driver amplifier that offers excellent dynamic range in a low cost, 6x6mm surface mount package. This device can be biased as low as +9V for lower power applications and as high as +12V for improved P1dB and OIP3 performance.

The backside metalization allows excellent thermal dissipation while allowing visible evidence of solder reflow throughout the bottom of the package on a SMT board. Superior thermal design allows the product an MTBF of over 100 years at a mounting temperature of +85°C. All devices are 100% RF & DC tested.

The product is targeted for use as driver amplifiers for wireless infrastructure where high linearity and medium power is required.

Functional Diagram

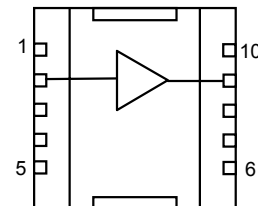

Top View

Function	Pin No.
Input	2
Output/Bias	9
Ground	1, 2, 3, 5
Ground	6, 7, 8, 10
Not Connected	4

Specifications

Parameters	Units	Min	Typ.	Max
Frequency Range	MHz		400-2200	
S21 - Gain	dB		15	
S11 - Input Return Loss	dB		-9.5	
S22 - Output Return Loss	dB		-10	
Noise Figure	dB		4	
Output P1dB	dBm		+30	
Output IP3	dBm		+47	
Operating Current Range	mA	310	330	370
Supply Voltage	V		11	
Thermal Resistance	Rth			14

Test conditions unless otherwise noted.
 1. T = 25°C, Vdd = 11V, Frequency = 800 MHz, 50 Ohm system.
 2. 3OIP measured with two tones at an output power of 10 dBm/tone separated by 10 MHz.
 The suppression on the largest IM3 product is used to calculate the 3OIP using a 2:1 rule.

Typical Specifications

Parameters	Units	Typical		
Frequency	MHz	900	1900	2200
S21 - Gain	dB	17	15	14
S11 - Input R.L.	dB	-13	-9.5	-9.3
S22 - Output R.L.	dB	-15	-9.5	-9.0
Noise Figure	dB	3.8	4.3	4.4
Output P1dB	dBm	+30.0	+29.5	+29.3
Output IP3	dBm	+47	+47	+47
IS-95 Channel Power @ -45dBc ACPR	dBm	+24	+23.6	+23.5

Typical parameters reflect performance in an application circuit.
 1. T = 25°C, Vdd = 11V
 2. 3OIP measured with two tones at an output power of 10 dBm/tone separated by 10 MHz.
 The suppression on the largest IM3 product is used to calculate the 3OIP using a 2:1 rule.

Recommended Maximum Rating

Parameters	Rating
Operating Case Temperature	-40 to +85 °C
Storage Temperature	-40 to +125 °C
DC Voltage	+15 V
RF Input Power (continuous)	+20 dBm
Junction Temperature	+155° C

Ordering Information

Part No.	Description
AH201	Med. Power High Linearity Amp. (Available in Tape & Reel)
AH201-PCB-900	400-1000 MHz Evaluation Board
AH201-PCB-1900	1600-2200 MHz Evaluation Board



AH201

Medium Power, High Linearity Amplifier

Preliminary Product Information

Application Circuit: 900 MHz and 1900 MHz

Typical Specifications

Frequency	MHz	900	1900	2200
S21 - Gain	dB	17	15	14
S11 - Input R.L.	dB	-13	-9.5	-9.3
S22 - Output R.L.	dB	-15	-9.5	-9.0
Noise Figure	dB	3.8	4.3	4.4
Output P1dB	dBm	+30.0	+29.5	+29.3
Output IP3	dBm	+47	+47	+47
IS-95 Channel Power @ -45dBc ACPR	dBm	+24	+23.6	+23.5

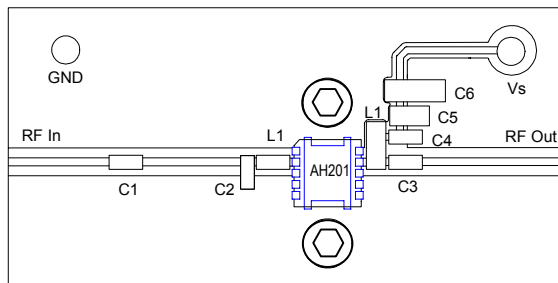

Board Material: 14 mil GETEK ($\epsilon_r = 4.1$)
 Line Width: 28 mil
 Line Spacing: 36 mil

Notes:

- Via holes are omitted for clarity.
- The microstrip line is weakly co-planar. Ground planes around it are not necessary for operation of the AH201.
- Adequate heat sinking is required for the device. Further mounting instructions will be shown in the "Mounting Configuration" section of this datasheet on the next revision for the datasheet.
- The pin configuration must be soldered accordingly (shown on the "Functional Diagram").
- The 900 MHz application circuit board is labeled as AH201-PCB-900.
- The 1900 MHz and 2200 MHz application circuit board is labeled as AH201-PCB-1900.

CIRCUIT SCHEMATIC

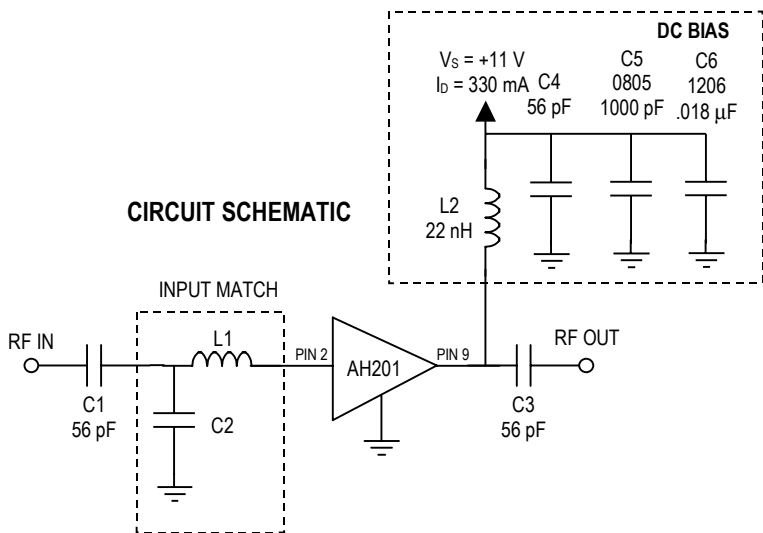

900 MHz

L1 = 3.3 nH
 C2 = 2.2 pF
 AH201-PCB-900

1900 MHz

L1 = 0 Ω
 C2 = no load
 AH201-PCB-1900

2200 MHz

L1 = 0 Ω
 C2 = no load
 AH201-PCB-1900



AH201

Medium Power, High Linearity Amplifier

Preliminary Product Information

Outline Drawing

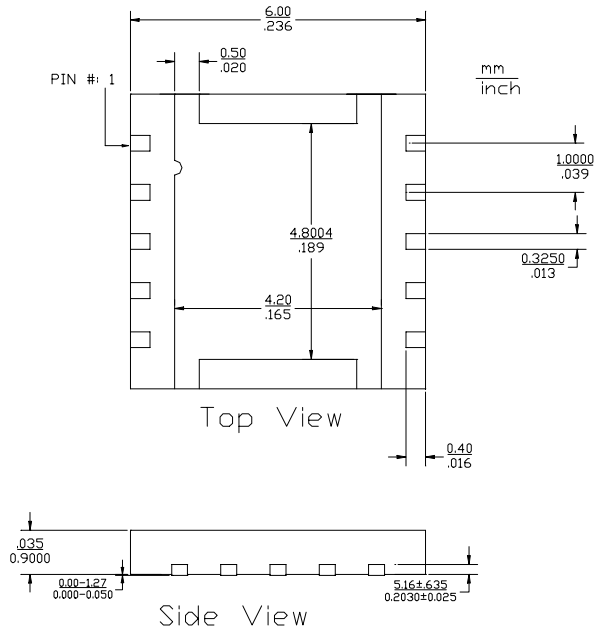

Mounting Configuration

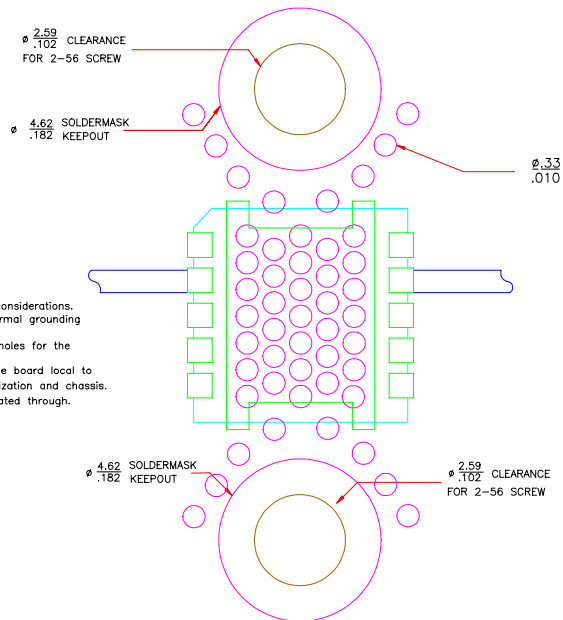

- Notes:
1. Ground vias are critical for thermal and RF grounding considerations.
 2. Two 2-56 screws with washers should be used for thermal grounding to the main chassis.
 3. Ground plane on the backside should extend past the holes for the 2-56 screws as a minimum.
 4. No soldermask should be applied to the backside of the board local to the part to ensure contact between the backside metalization and chassis.
 5. Via holes and holes for the 2-56 screws should be plated through.
 6. Trace width depends on PC board.
 7. A minimum of 1 oz. / 1 oz. copper should be used.

This document contains information on a new product. Specifications and information are subject to change without notice.



AH201

Medium Power, High Linearity Amplifier

The Communications Edge™

Preliminary Product Information

Typical Test Data

S-Parameters ($V_{DS} = +10V$, $I_{DS} = 360$ mA, $T = 25^{\circ}C$, unmatched device in a 50Ω system)

Freq (MHz)	S11 (dB)	S11 (ang)	S21 (dB)	S21 (ang)	S12 (dB)	S12 (ang)	S22 (dB)	S22 (ang)
200	-18.13	-141.77	17.77	156.16	-21.60	-12.80	-15.22	158.80
400	-14.01	-151.43	17.47	134.85	-22.01	-27.05	-15.91	138.77
600	-11.32	-161.69	17.03	113.80	-22.50	-40.65	-19.50	119.22
800	-9.60	-175.43	16.52	93.61	-23.08	-54.53	-28.09	86.76
1000	-8.38	170.85	15.98	74.11	-23.75	-66.32	-28.42	-67.31
1200	-7.72	156.06	15.50	55.43	-24.58	-80.56	-18.92	-96.94
1400	-7.51	140.70	15.09	37.11	-25.23	-94.35	-14.49	-115.52
1600	-7.69	123.37	14.78	18.41	-25.58	-107.34	-11.68	-131.45
1800	-8.42	102.05	14.63	-0.87	-26.55	-124.66	-9.76	-146.54
2000	-9.90	76.87	14.53	-21.84	-26.58	-144.30	-7.87	-160.86
2200	-12.60	27.48	14.50	-45.98	-26.08	-170.04	-7.03	-176.78
2400	-11.30	-52.35	14.07	-74.59	-25.82	158.59	-7.07	169.02
2600	-6.47	-110.35	12.82	-105.64	-25.42	125.63	-7.82	159.81
2800	-3.46	-149.16	10.54	-135.77	-25.19	97.73	-8.39	158.80
3000	-2.00	-178.37	7.60	-161.74	-25.67	70.96	-7.81	158.95

S-Parameters ($V_{DS} = +11V$, $I_{DS} = 360$ mA, $T = 25^{\circ}C$, unmatched device in a 50Ω system)

Freq (MHz)	S11 (dB)	S11 (ang)	S21 (dB)	S21 (ang)	S12 (dB)	S12 (ang)	S22 (dB)	S22 (ang)
200	-18.23	-140.99	17.78	156.01	-21.55	-12.99	-15.65	157.55
400	-13.98	-150.55	17.45	134.66	-21.89	-26.89	-16.32	136.16
600	-11.28	-161.20	17.01	113.54	-22.42	-40.61	-20.06	113.27
800	-9.55	-174.85	16.51	93.30	-22.97	-54.78	-28.14	66.80
1000	-8.37	170.96	15.97	73.75	-23.63	-68.09	-25.96	-57.60
1200	-7.72	156.06	15.48	54.97	-24.49	-80.75	-18.30	-91.67
1400	-7.52	140.70	15.06	36.62	-25.19	-92.07	-14.20	-111.26
1600	-7.63	123.63	14.76	17.90	-25.65	-110.24	-11.62	-128.20
1800	-8.33	101.89	14.61	-1.59	-26.17	-126.52	-9.75	-144.01
2000	-9.90	76.65	14.52	-22.62	-26.54	-146.07	-7.92	-158.95
2200	-12.60	27.68	14.47	-46.91	-26.12	-171.34	-7.13	-174.81
2400	-11.31	-52.94	14.03	-75.60	-25.97	158.68	-7.18	170.91
2600	-6.49	-110.68	12.76	-106.82	-25.45	124.53	-7.89	162.45
2800	-3.44	-149.63	10.46	-136.86	-25.52	96.19	-8.36	161.68
3000	-2.05	-178.91	7.50	-162.88	-25.80	71.90	-7.77	161.32

S-Parameters ($V_{DS} = +12V$, $I_{DS} = 360$ mA, $T = 25^{\circ}C$, unmatched device in a 50Ω system)

Freq (MHz)	S11 (dB)	S11 (ang)	S21 (dB)	S21 (ang)	S12 (dB)	S12 (ang)	S22 (dB)	S22 (ang)
200	-18.35	-139.11	17.75	155.83	-21.46	-12.62	-16.01	156.27
400	-13.96	-149.61	17.42	134.38	-21.90	-27.52	-16.71	134.14
600	-11.27	-160.54	16.97	113.21	-22.28	-41.26	-20.68	108.17
800	-9.51	-174.44	16.46	92.97	-22.95	-54.74	-27.61	52.71
1000	-8.29	171.17	15.92	73.44	-23.62	-66.33	-24.66	-52.59
1200	-7.65	156.23	15.44	54.51	-24.34	-80.72	-17.92	-86.86
1400	-7.46	140.57	15.02	36.13	-25.26	-95.25	-14.07	-108.70
1600	-7.60	123.49	14.70	17.27	-25.70	-109.40	-11.57	-126.27
1800	-8.36	102.04	14.55	-2.24	-26.19	-126.14	-9.74	-142.18
2000	-9.83	76.66	14.45	-23.38	-26.34	-147.66	-7.94	-157.44
2200	-12.66	26.81	14.41	-47.75	-26.11	-171.50	-7.19	-173.18
2400	-11.27	-53.63	13.95	-76.69	-25.80	158.48	-7.30	172.65
2600	-6.43	-111.31	12.64	-107.97	-25.53	126.43	-8.02	164.30
2800	-3.48	-150.13	10.33	-138.03	-25.41	96.00	-8.31	164.25
3000	-2.07	-179.12	7.37	-163.88	-25.85	70.82	-7.60	163.02

This document contains information on a new product. Specifications and information are subject to change without notice.