

Silicon Schottky Diode

Preliminary data

- General-purpose diode for high-speed switching
- Circuit protection
- Voltage clamping
- High-level detecting and mixing
- Available with CECC quality assessment

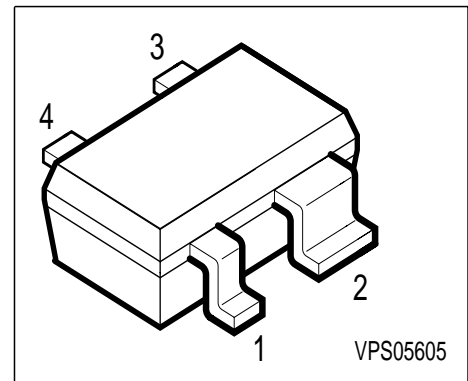

BAS 40-07W

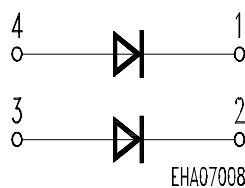

Type	Marking	Ordering Code	Pin Configuration				Package
BAS 40-07W	47s	Q62702-	1=C1	2=C2	3=A2	4=A1	SOT-343

Maximum Ratings

Parameter	Symbol	Value	Unit
Diode reverse voltage	V_R	40	V
Forward current	I_F	120	mA
Surge forward current, $t \leq 10\text{ms}$	I_{FSM}	200	
Total power dissipation, $T_S \leq 81^\circ\text{C}$	P_{tot}	250	mW
Junction temperature	T_j	150	$^\circ\text{C}$
Operating temperature range	T_{op}	- 55 ...+150	
Storage temperature	T_{stg}	- 55 ...+150	

Maximum Ratings

Junction - ambient ¹⁾	R_{thJA}	≤ 345	K/W
Junction - soldering point	R_{thJS}	≤ 275	

1) Package mounted on epoxy pcb 40mm x 40mm x 1.5mm / 6cm² Cu

Electrical Characteristics at $T_A = 25^\circ\text{C}$, unless otherwise specified.

Parameter	Symbol	Values			Unit
		min.	typ.	max.	
DC characteristics					
Breakdown voltage $I_{(BR)} = 10 \mu\text{A}$	$V_{(BR)}$	40	-	-	V
Reverse current $V_R = 30 \text{ V}$ $V_R = 40 \text{ V}$	I_R	- -	- -	1 10	μA
Forward voltage $I_F = 1 \text{ mA}$ $I_F = 10 \text{ mA}$ $I_F = 40 \text{ mA}$	V_F	- - -	310 450 720	380 500 1000	mV
AC characteristics					
Diode capacitance $V_R = 0 \text{ V}, f = 1 \text{ MHz}$	C_T	-	4	5	pF
Charge carrier life time $I_F = 25 \text{ mA}$	τ	-	-	100	ps
Differential forward resistance $I_F = 10 \text{ mA}, f = 10 \text{ kHz}$	r_f	-	10	-	Ω

Forward current $I_F = f(V_F)$

$T_A = 25^\circ\text{C}$

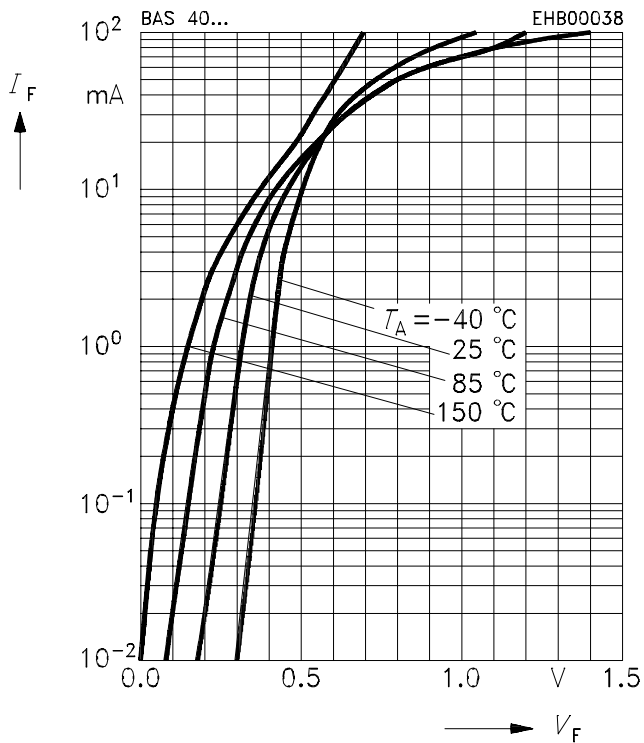

Reverse current $I_R = f(V_R)$

$T_A = \text{Parameter}$

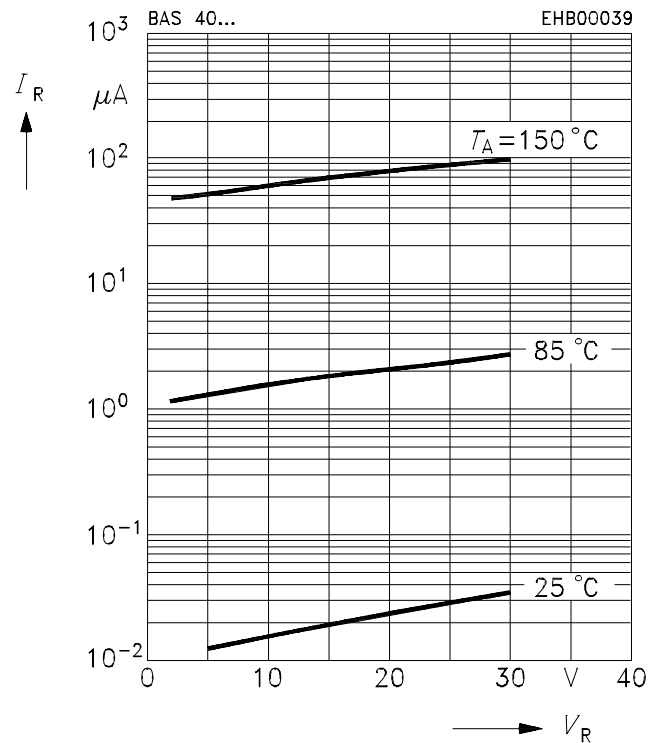

Diode capacitance $C_T = f(V_R)$

$f = 1\text{MHz}$

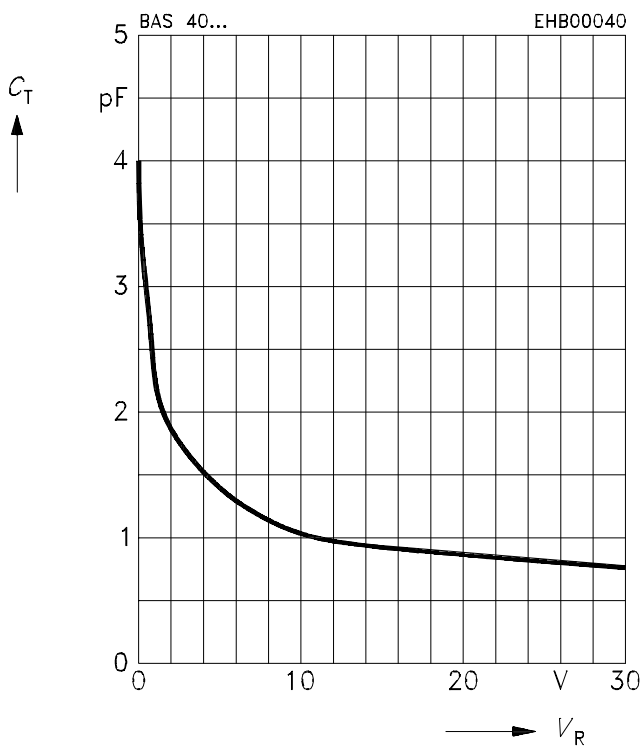

Differential forward resistance $r_f = f(I_F)$

$f = 10\text{kHz}$

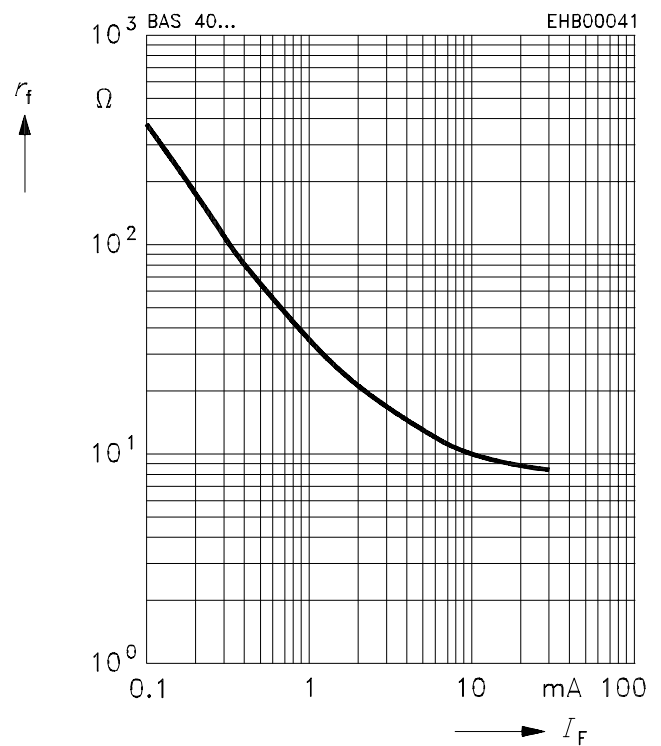

Forward current $I_F = f(T_A^*; T_S)$

* Package mounted on alumina

