

## Silicon Schottky Diode

**BAT 17-07**

- For mixer applications in the VHF/UHF range
- For high-speed switching

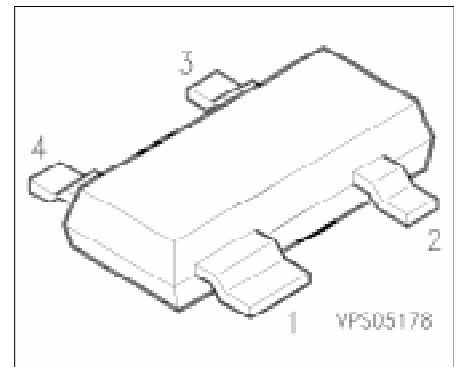

Type	Ordering Code (tape and reel)	Pin Configuration				Marking	Package
		1	2	3	4		
BAT 17-07	Q62702-A918	C1	C2	A2	A1	57	SOT-143

### Maximum Ratings

Parameter	Symbol	Values	Unit
Reverse voltage	$V_R$	4	V
Forward current	$I_F$	130	mA
Total power dissipation $T_S \leq 60\text{ °C}$	$P_{tot}$	150	mW
Junction temperature	$T_j$	150	°C
Operating temperature range	$T_{op}$	- 55 ... + 150	°C
Storage temperature range	$T_{stg}$	- 55 ... + 150	°C

### Thermal Resistance

Junction-ambient <sup>1)</sup>	$R_{th JA}$	≤ 750	K/W
Junction-soldering point	$R_{th JS}$	≤ 590	K/W

1) Package mounted on epoxy pcb 40 mm x 40 mm x 1.5 mm/1cm<sup>2</sup> Cu.

## Electrical Characteristics

at  $T_A = 25\text{ °C}$ , unless otherwise specified.

Parameter	Symbol	Value			Unit
		min.	typ.	max.	
<b>DC Characteristics</b>					
Breakdown voltage $I_R = 10\text{ }\mu\text{A}$	$V_{(BR)}$	4	–	–	V
Reverse current $V_R = 3\text{ V}$ $V_R = 3\text{ V}, T_A = 60\text{ °C}$ $V_R = 4\text{ V}$	$I_R$	–	–	0.25 1.25 10	$\mu\text{A}$
Forward voltage $I_F = 0.1\text{ mA}$ $I_F = 1\text{ mA}$ $I_F = 10\text{ mA}$	$V_F$	200 750 350	275 340 425	350 450 600	mV
Diode capacitance $V_R = 0\text{ V}, f = 1\text{ MHz}$	$C_T$	–	0.75	1	pF
Differential forward resistance $I_F = 5\text{ mA}, f = 10\text{ kHz}$	$r_S$	–	8	15	$\Omega$

**Forward current  $I_F = f(V_F)$**

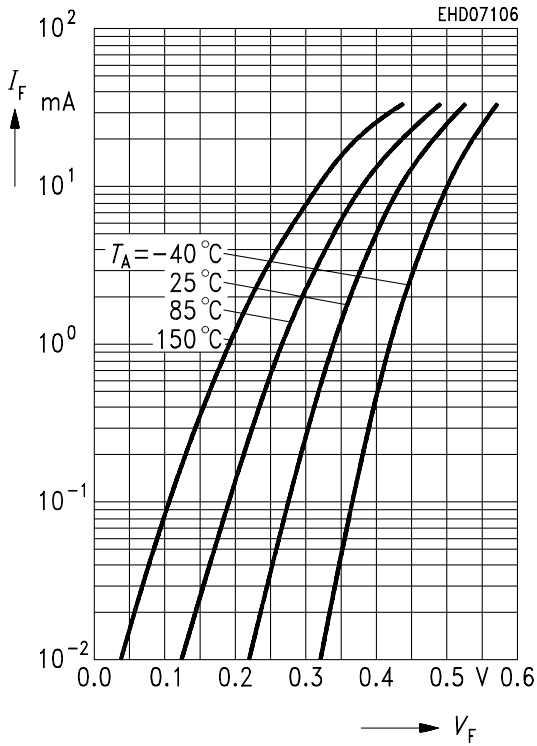

**Reverse current  $I_R = f(V_R)$**

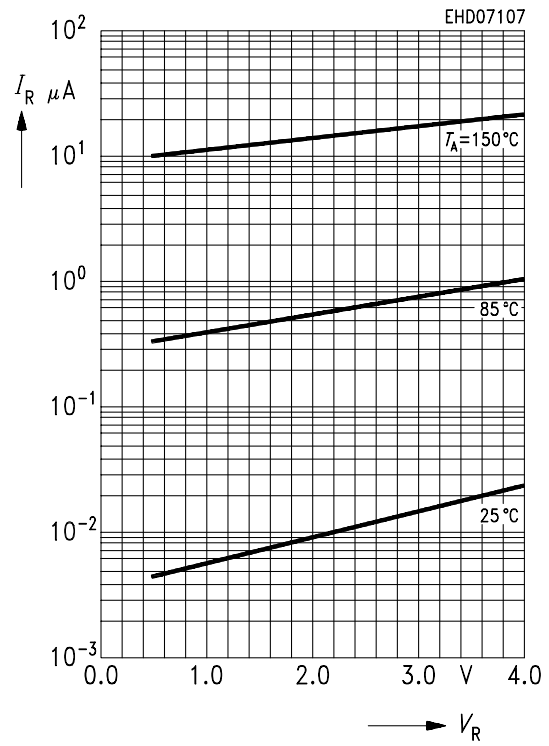

**Diode capacitance  $C_T = f(V_R)$**

$f = 1 \text{ MHz}$

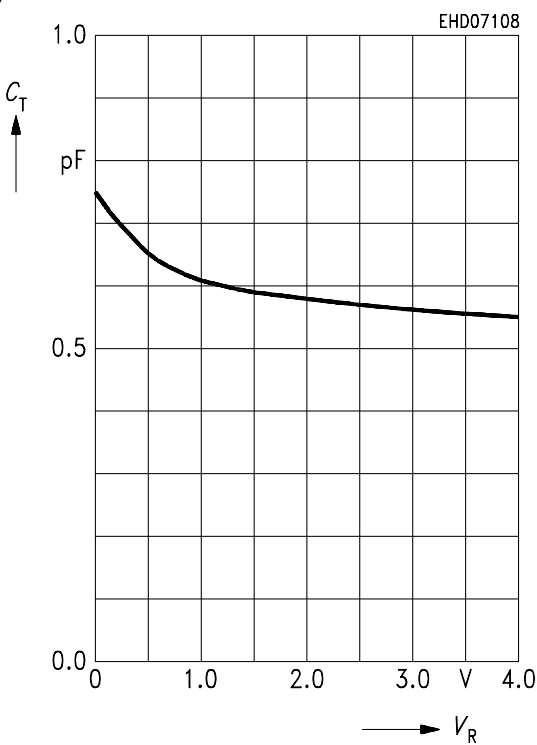

**Differential forward resistance  $R_F = f(I_F)$**

$f = 10 \text{ kHz}$

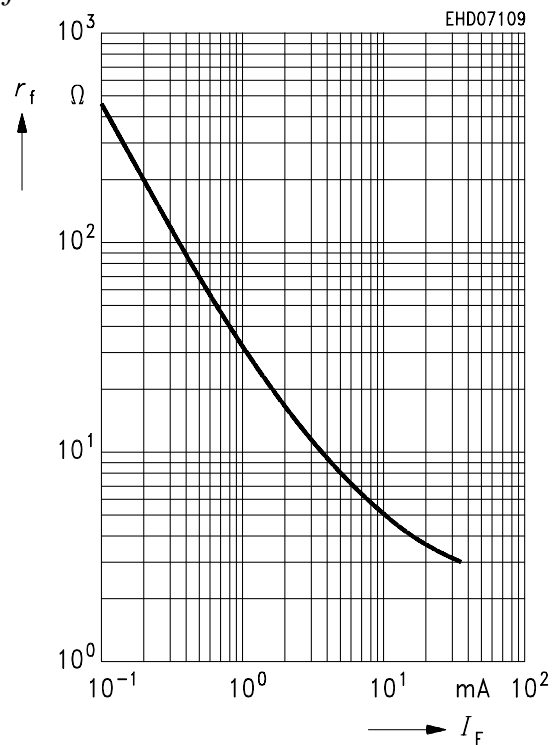

Forward current  $I_F = f(T_A; T_S^*)$

\*Package mounted on aluminum

