

## ICs for Communications

Memory Time Switch Extended Large  
MTSXL

PEB 2447 Version 1.2

Data Sheet 03.97

T2447-XV12-D2-7600

<b>PEB 2447</b>		
<b>Revision History:</b>		<b>Current Version: 03.97 (Editorial Update)</b>
Previous Version:		01.95
Page (in previous Version)	Page (in current Version)	Subjects (major changes since last revision)
-	32	Register Address Arrangement (new)

### **Edition 03.97**

This edition was realized using the software system FrameMaker®.

**Published by Siemens AG,  
Bereich Halbleiter, Marketing-  
Kommunikation, Balanstraße 73,  
81541 München**

© Siemens AG 1997.  
All Rights Reserved.

### **Attention please!**

As far as patents or other rights of third parties are concerned, liability is only assumed for components, not for applications, processes and circuits implemented within components or assemblies.

The information describes the type of component and shall not be considered as assured characteristics.

Terms of delivery and rights to change design reserved.

For questions on technology, delivery and prices please contact the Semiconductor Group Offices in Germany or the Siemens Companies and Representatives worldwide (see address list).

Due to technical requirements components may contain dangerous substances. For information on the types in question please contact your nearest Siemens Office, Semiconductor Group.

Siemens AG is an approved CECC manufacturer.

### **Packing**

Please use the recycling operators known to you. We can also help you – get in touch with your nearest sales office. By agreement we will take packing material back, if it is sorted. You must bear the costs of transport.

For packing material that is returned to us unsorted or which we are not obliged to accept, we shall have to invoice you for any costs incurred.

### **Components used in life-support devices or systems must be expressly authorized for such purpose!**

Critical components<sup>1</sup> of the Semiconductor Group of Siemens AG, may only be used in life-support devices or systems<sup>2</sup> with the express written approval of the Semiconductor Group of Siemens AG.

- 1 A critical component is a component used in a life-support device or system whose failure can reasonably be expected to cause the failure of that life-support device or system, or to affect its safety or effectiveness of that device or system.
- 2 Life support devices or systems are intended (a) to be implanted in the human body, or (b) to support and/or maintain and sustain human life. If they fail, it is reasonable to assume that the health of the user may be endangered.

<b>Table of Contents</b>		<b>Page</b>
<b>1</b>	<b>Overview</b> .....	4
1.1	Features .....	4
1.2	Logic Symbol .....	5
1.3	General Device Overview .....	5
1.4	Pin Configuration .....	6
1.5	Pin Definitions and Functions .....	6
<b>2</b>	<b>Functional Description</b> .....	11
2.1	General Operation .....	11
2.2	Special Functions .....	13
2.2.1	Control Memory Reset .....	13
2.2.2	Evaluate Frame Measurement Signal .....	13
2.2.3	MTSXL Selftest .....	13
2.3	Boundary Scan and TAP Controller .....	14
2.3.1	Boundary Scan .....	14
2.3.2	TAP Controller .....	18
2.3.3	Use of Built in Selftest via the Boundary Scan Interface .....	19
2.3.4	IDCODE .....	22
<b>3</b>	<b>Operational Description</b> .....	23
3.1	Initialization Procedure .....	23
3.2	Operation Mode .....	23
3.3	Indirect Access Registers .....	23
3.4	Frame Evaluation .....	24
3.5	Input Offset and Output Offset .....	25
3.6	Frame Delay .....	27
<b>4</b>	<b>Detailed Register Description</b> .....	32
4.1	Register Address Arrangement .....	32
4.2	Mode Register (MODR) .....	33
4.3	Command Register (CMDR) .....	34
4.4	Status Register (STAR) .....	35
4.5	Interrupt Status Register (ISTA) .....	36
4.6	Mask Register (MASK) .....	37
4.7	Memory Access Address/Code Register High (MACH) .....	37
4.8	Memory Access Address Register Low (MAAL) .....	38
4.9	Memory Read Data Register Low (MRDL) .....	39
4.10	Memory Read Data Register High (MRDH) .....	39
4.11	Memory Write Data Register Low (MWDL) .....	39
4.12	Memory Write Data Register High (MWDH) .....	40
4.13	Input Clock Shift Register Bank ICSR (15:0) .....	41
4.14	Output Clock Shift Register (OSCR) .....	42
4.15	Test Register (TSTR) .....	42
4.16	Frame Evaluation Register Low (FERL) .....	43
4.17	Frame Evaluation Register High (FERH) .....	43
<b>5</b>	<b>Electrical Characteristics</b> .....	44
<b>6</b>	<b>Package Outlines</b> .....	51

## Memory Time Switch Extended Large MTSXL

PEB 2447

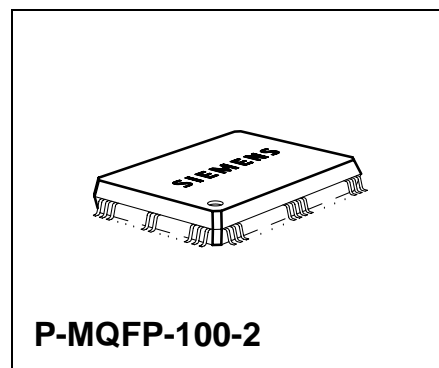
Version 1.2

CMOS IC

### 1 Overview

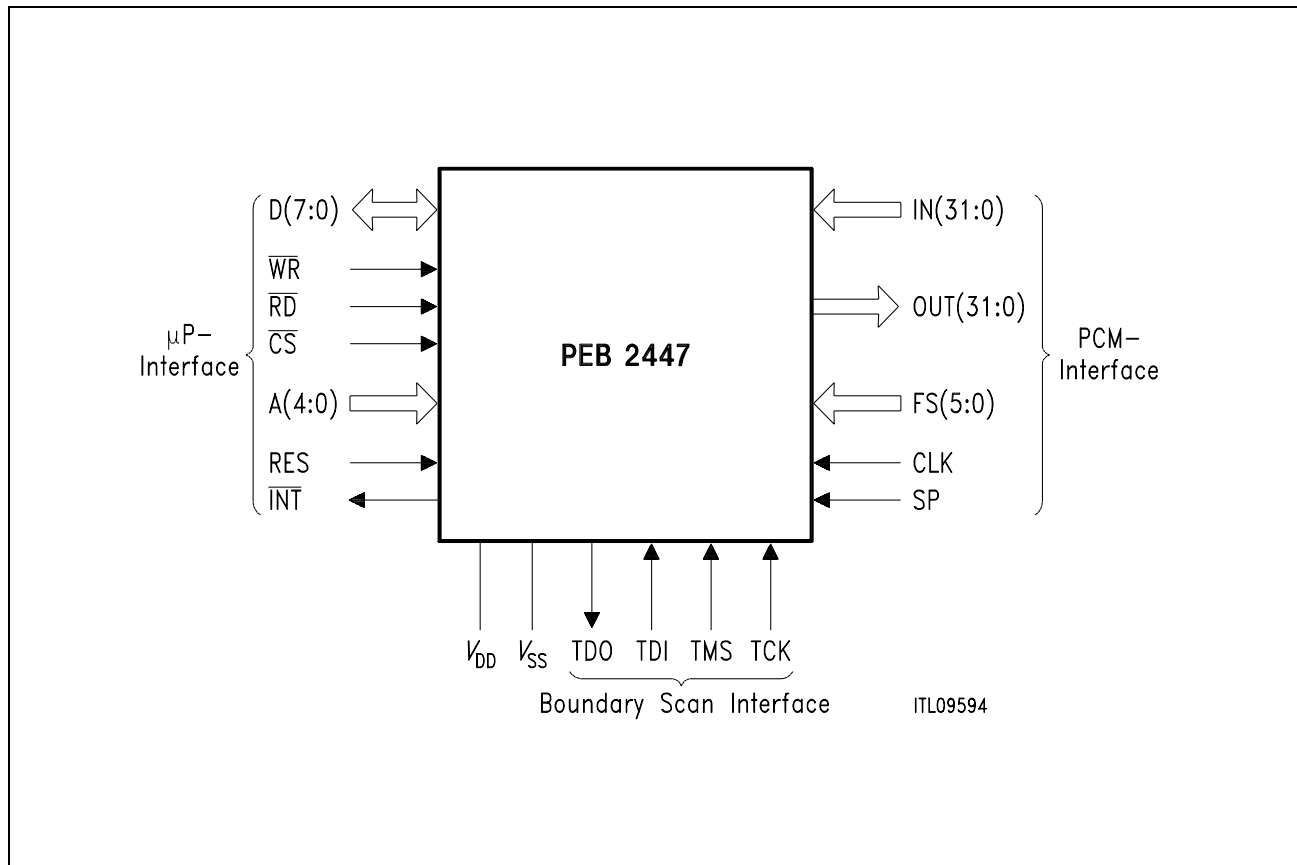
#### 1.1 Features

- Non blocking time/space switch for 4.096- or 8.192-Mbit/s PCM systems
- Device clock 16.384 MHz
- Switching of up to 2048 incoming PCM channels to up to 2048 outgoing PCM channels
- 32 input and 32 output PCM lines
- Tristate function for further expansion and tandem operation
- $\mu$ P read access to PCM data
- Programmable clock shift with half clock step resolution for input and output
- Individual line delay measurement for 6 additional inputs
- Individual input offset programmable for 16 PCM inputs
- Boundary scan (fully IEEE1149.1 compatible)
- Built-in selftest (also usable via boundary scan interface)
- 8-bit Intel type demultiplexed  $\mu$ P interface
- All registers accessible by direct addressing
- In-operation adjustment of bit sampling without bit errors
- Low power consumption
- Single 5 V power supply



Type	Ordering Code	Package
PEB 2447 H	Q67103-H6594	P-MQFP-100-2

## 1.2 Logic Symbol



**Figure 1**  
**Functional Symbol**

## 1.3 General Device Overview

The Siemens Memory Time Switch Extended Large MTSXL (PEB 2447) is a capacity expansion of the MTSL (PEB 2047). It is a monolithic CMOS switching device capable of connecting maximally 2048 PCM input time slots to 2048 output time slots. In order to manage the problem of different line delays, six additional FS inputs can be used as frame measurement inputs and 16 different input offsets of PCM frames are allowed. Thus a frame wander can be compensated by adjusting the input offset during operation. A special circuitry guarantees that no bit error will occur, when reprogramming the input offsets.

The MTSXL on chip connection memory and data memory are accessed via the 8-bit standard  $\mu$ P interface (Intel demultiplexed type).

A built-in selftest mechanism – also activated by the  $\mu$ P – ensures proper device operation in the system.

The PEB 2447 is fabricated using the advanced CMOS technology from Siemens and is mounted in a P-MQFP-100-2 package. Inputs and outputs are TTL compatible.

1.4 Pin Configuration  
(top view)

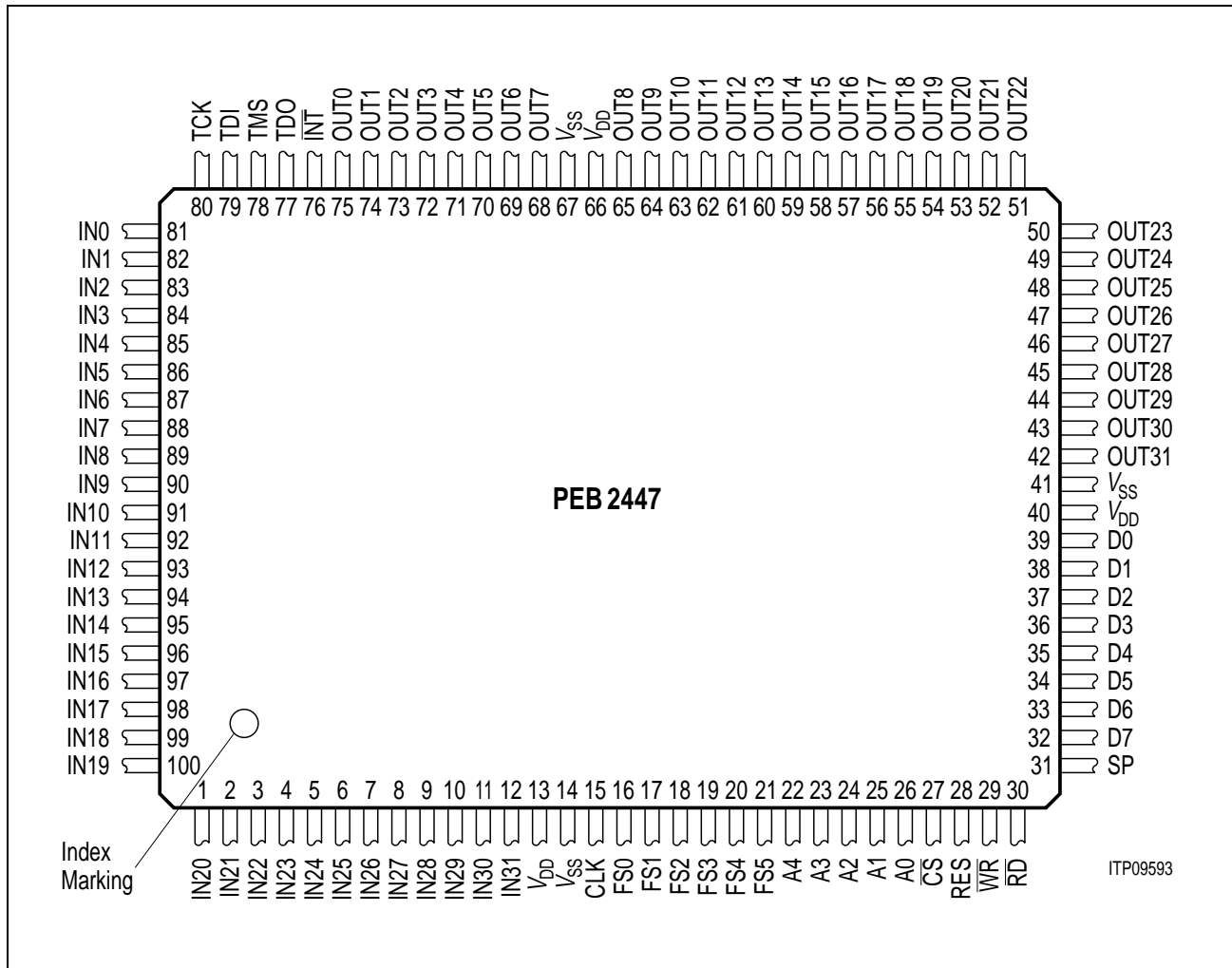


Figure 2

1.5 Pin Definitions and Functions

Pin No.	Symbol	Input (I) Output (O) Tristate (T)	Function
14 41 67	V <sub>SS</sub>	I	Ground (0 V)
13 40 66	V <sub>DD</sub>	I	Supply Voltage: 5 V ± 5 %.

## 1.5 Pin Definitions and Functions (cont'd)

Pin No.	Symbol	Input (I) Output (O) Tristate (T)	Function
81	IN0	I	<b>PCM Input Ports:</b> Serial data is received at standard TTL levels.
82	IN1	I	
83	IN2	I	
84	IN3	I	
85	IN4	I	
86	IN5	I	
87	IN6	I	
88	IN7	I	
89	IN8	I	
90	IN9	I	
91	IN10	I	
92	IN11	I	
93	IN12	I	
94	IN13	I	
95	IN14	I	
96	IN15	I	
97	IN16	I	
98	IN17	I	
99	IN18	I	
100	IN19	I	
1	IN20	I	
2	IN21	I	
3	IN22	I	
4	IN23	I	
5	IN24	I	
6	IN25	I	
7	IN26	I	
8	IN27	I	
9	IN28	I	
10	IN29	I	
11	IN30	I	
12	IN31	I	
15	CLK	I	<b>Clock:</b> 16.384 MHz device clock.

## 1.5 Pin Definitions and Functions (cont'd)

Pin No.	Symbol	Input (I) Output (O) Tristate (T)	Function
16 17 18 19 20 21	FS0 FS1 FS2 FS3 FS4 FS5	I I I I I I	<b>Frame Measuring Inputs:</b> These inputs are used as frame evaluation inputs.
26 25 24 23 22	A0 A1 A2 A3 A4	I I I I I	<b>Address Bus Bit 0 to 4:</b> These inputs interface to the systems address bus to select an internal register for a read or write access.
27	$\overline{CS}$	I	<b>Chip Select:</b> (low active) A low level selects the MTSXL for a register access operation.
28	RES	I	<b>Reset:</b> A high signal on this Input forces the MTSXL into reset state.
29	$\overline{WR}$	I	<b>Write:</b> (low active) This signal indicates a write operation.
30	$\overline{RD}$	I	<b>Read:</b> (low active) This signal indicates a read operation.
31	SP	I	<b>Synchronization Pulse:</b> The MTSXL is synchronized to the PCM system via this line.
39 38 37 36 35 34 33 32	D0 D1 D2 D3 D4 D5 D6 D7	I/O/T I/O/T I/O/T I/O/T I/O/T I/O/T I/O/T I/O/T	<b>Data Bus:</b> These pins transfer data between the $\mu P$ and the MTSXL.

## 1.5 Pin Definitions and Functions (cont'd)

Pin No.	Symbol	Input (I) Output (O) Tristate (T)	Function
75	OUT0	O/T	<b>PCM Output Port:</b> Serial data is sent by these lines. These pins can be tristated.
74	OUT1	O/T	
73	OUT2	O/T	
72	OUT3	O/T	
71	OUT4	O/T	
70	OUT5	O/T	
69	OUT6	O/T	
68	OUT7	O/T	
65	OUT8	O/T	
64	OUT9	O/T	
63	OUT10	O/T	
62	OUT11	O/T	
61	OUT12	O/T	
60	OUT13	O/T	
59	OUT14	O/T	
58	OUT15	O/T	
57	OUT16	O/T	
56	OUT17	O/T	
55	OUT18	O/T	
54	OUT19	O/T	
53	OUT20	O/T	
52	OUT21	O/T	
51	OUT22	O/T	
50	OUT23	O/T	
49	OUT24	O/T	
48	OUT25	O/T	
47	OUT26	O/T	
46	OUT27	O/T	
45	OUT28	O/T	
44	OUT29	O/T	
43	OUT30	O/T	
42	OUT31	O/T	
76	$\overline{\text{INT}}$	O (Open Drain)	<b>Interrupt Line:</b> Active low. Reset when reading ISTA
77	TDO	O/T	<b>Test Data Output:</b> In the appropriate TAP controller state test data, an instruction or the selftest result is shifted out via this line.

## 1.5 Pin Definitions and Functions (cont'd)

Pin No.	Symbol	Input (I) Output (O) Tristate (T)	Function
78	TMS	I (internal pull-up)	<b>Test Mode Select:</b> 0 -> 1 transitions on this pin are required to step through the TAP controller state machine.
79	TDI	I (internal pull-up)	<b>Test Data Input:</b> In the appropriate TAP controller state test data or an instruction is shifted in via this line.
80	TCK	I	<b>Test Clock:</b> Single rate test data clock (6.25 MHz)

## **2 Functional Description**

The MTSXL is a memory time switch device. Operating with a device clock of 16.384 MHz it can connect any of 2048 PCM input channels to any of 2048 output channels.

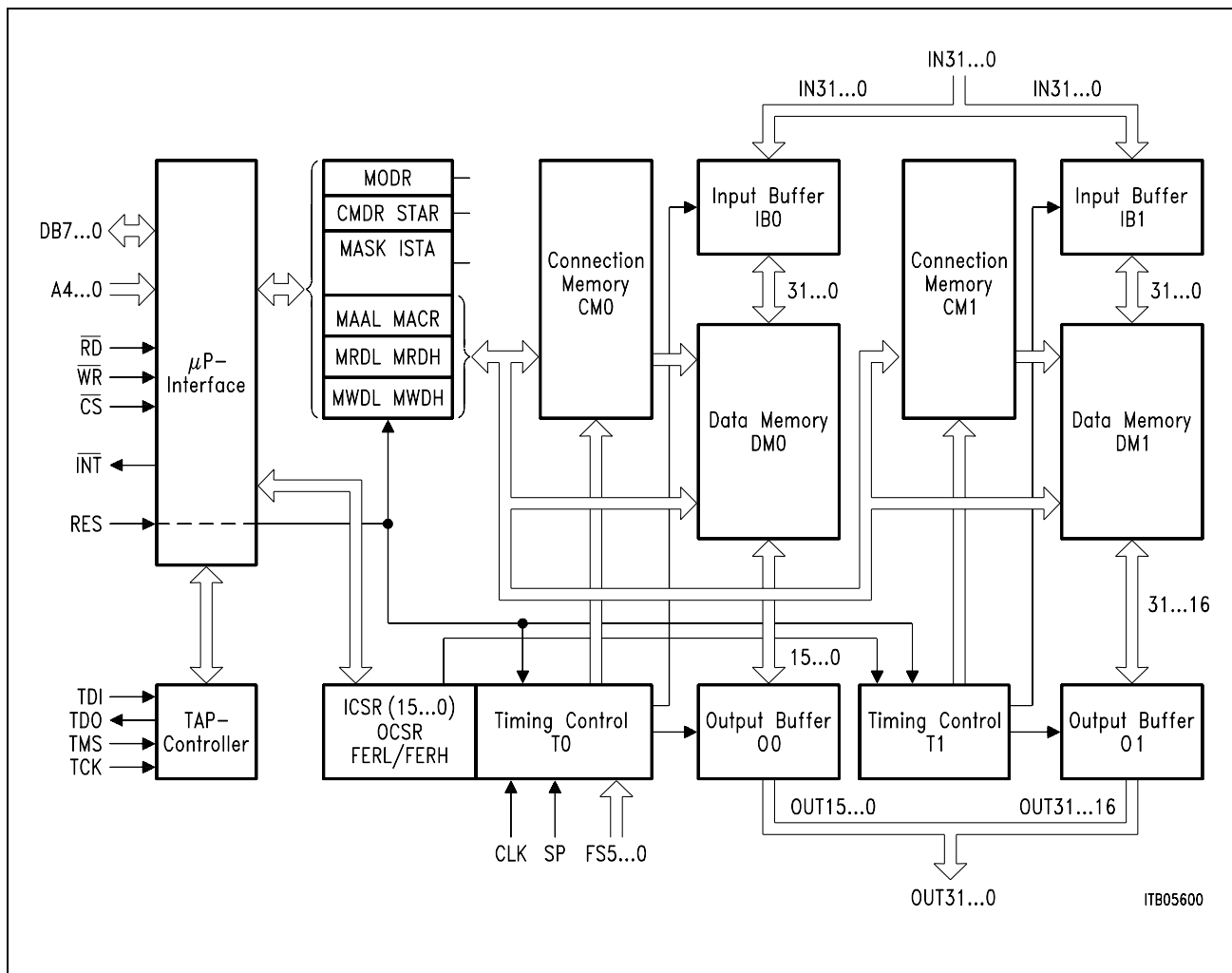
A general block diagram of the MTSXL is shown in **figure 3**.

### **2.1 General Operation**

The input information of a complete frame is stored twice in the two on-chip 16-kbit data memories DM 0 and DM 1 (Data Memory 0 and Data Memory 1). The incoming 2048 channels of 8 bits each are written in sequence into fixed positions of DM 0 and DM 1. This is controlled by the input counter in the timing control block with a 8 kHz repetition rate.

For outputting, two connection memories (CM 0 and CM 1) are read in sequence synchronously. Each entry in the connection memory CM 0 / CM 1 points to a location in data memory DM 0 / DM 1. The byte in this data memory location is transferred into the current output time slot. The read access to the CM's is controlled by an output counter. CM 0 supplies the PCM data for outputs OUT0 to OUT15, CM 1 supplies the PCM data for outputs OUT16 to OUT31.

Functional Description



**Figure 3**  
**Block Diagram of MTSXL**

The synchronization of the input and output counters is achieved by a rising edge of the sync pulse SP, which is always sampled with the falling edge of the device clock.

Different modes of operation are configurable at the PCM interfaces (see **table 9**). Furthermore, 16 PCM input lines can be aligned with individual clock shift values to compensate different line delays. If 32 inputs are used, one clock shift value controls two ports at the same time.

Shifting of the output frame is also possible, but all output lines are affected the same way.

The input lines FS0 to FS5 are used as frame measurement inputs. After synchronizing the device by the SP pulse the FS inputs can be evaluated on a per port basis. This evaluation procedure is started by a microprocessor command. As a result the input counter value on the rising edge of the FS signal can be read from an internal register. Thus delay compensation is easily managed by programming appropriate clock shift values and/or a possible software offset.

---

## Functional Description

During operation of the chip a frame length check is also supplied, which controls correct synchronization by the SP pulse and generates an interrupt in case of lost or achieved synchronization.

The unused output ports are tristated by mode selection, whereas unused time slots are tristated by an additional bit in the control memory. By using this tristate capability the MTSXL can be easily expanded to a time switch of any size.

The standard 8-bit  $\mu$ P interface can communicate with Intel demultiplexed microprocessors. It gives access to the internal registers and to the control and data memory. All registers are directly addressable. The memories are accessed by a simple four byte indirect access method.

## 2.2 Special Functions

The activity of all special functions can be read in the status register. Completion of these functions is indicated by interrupts.

### 2.2.1 Control Memory Reset

Initialization of the device after a hardware reset (RES) is easily done with a  $\mu$ P command "control memory reset". After finishing this procedure all control memory channels contain the information "tristated". Apart from this tristate information the contents of the C Memory is undefined.

### 2.2.2 Evaluate Frame Measurement Signal

A command including the address (0 ... 5) will be given by the  $\mu$ P. The rising edge of the corresponding frame measurement signal (FS0 ... FS5) will be evaluated. The exact timing of the FS edge can then be read from an internal 12-bit register (resolution of a complete 8 kHz frame in half 16 MHz clock periods).

### 2.2.3 MTSXL Selftest

The switching path of the MTSXL including input buffer, data memory, control memory, output buffer and timing control can be tested in the system by a 2-step built-in selftest. Activating this mechanism takes  $2 \times 0.625$  ms (16.384 MHz). Finally the result "selftest ok/selftest not ok" can be read from the internal status register.

After test completion the control memory has also been reset (contains the information tristated).

The selftest can also be started and checked via the boundary scan interface.

*Note: For correct execution of the built-in selftest the MTSXL needs a value of ICSR = 00. If MODR:PSB = 0 (e.g. after hardware reset) this value is programmed automatically after start of the selftest procedure. If ICSR does not contain "00" with MODR:PSB = 1 the selftest will fail.*

## Functional Description

### 2.3 Boundary Scan and TAP Controller

#### 2.3.1 Boundary Scan

The MTSXL provides fully IEEE Std. 1149.1 compatible boundary scan support consisting of

- a complete boundary scan
- a test access port controller (TAP controller)
- four dedicated pins (TCK, TMS, TDI, TDO)
- a 32 bit IDCODE register

All pins except power supply and ground are included in the boundary scan. Depending on the pin functionality one, two or three boundary scan cells are provided:

**Table 1**  
**Boundary Scan Cell Type**

Pin Type	Number of Boundary Scan Cells	Usage
Input	1	Input
Output	2	Output, enable
I/O	3	Input, output, enable

When the TAP controller is in the appropriate mode data is shifted into / out of the boundary scan via the pins TDI / TDO using the 6.25 MHz clock on pin TCK.

The MTSXL pins are included in the boundary scan in the following sequence:

**Table 2**  
**Boundary Scan Sequence**

Boundary Scan Number TDI ->	Pin Number	Pin Name	Type	Number of Scan Cells	Default Value
1	81	IN0	I	1	0
2	82	IN1	I	1	0
3	83	IN2	I	1	1
4	84	IN3	I	1	0
5	85	IN4	I	1	0
6	86	IN5	I	1	0
7	87	IN6	I	1	0
8	88	IN7	I	1	0
9	89	IN8	I	1	0
10	90	IN9	I	1	0
11	91	IN10	I	1	0

## Functional Description

**Table 2**  
**Boundary Scan Sequence (cont'd)**

Boundary Scan Number TDI ->	Pin Number	Pin Name	Type	Number of Scan Cells	Default Value
12	92	IN11	I	1	0
13	93	IN12	I	1	0
14	94	IN13	I	1	0
15	95	IN14	I	1	1
16	96	IN15	I	1	0
17	97	IN16	I	1	0
18	98	IN17	I	1	1
19	99	IN18	I	1	0
20	100	IN19	I	1	1
21	1	IN20	I	1	0
22	2	IN21	I	1	0
23	3	IN22	I	1	0
24	4	IN23	I	1	0
25	5	IN24	I	1	1
26	6	IN25	I	1	0
27	7	IN26	I	1	0
28	8	IN27	I	1	0
29	9	IN28	I	1	0
30	10	IN29	I	1	0
31	11	IN30	I	1	1
32	12	IN31	I	1	1
33	15	CLK	I	1	0
34	16	FS0	I	1	0
35	17	FS1	I	1	0
36	18	FS2	I	1	0
37	19	FS3	I	1	0
38	20	FS4	I	1	0
39	21	FS5	I	1	0
40	22	A4	I	1	0
41	23	A3	I	1	0
42	24	A2	I	1	0

## Functional Description

**Table 2**  
**Boundary Scan Sequence (cont'd)**

Boundary Scan Number TDI ->	Pin Number	Pin Name	Type	Number of Scan Cells	Default Value
43	25	A1	I	1	0
44	26	A0	I	1	0
45	27	$\overline{CS}$	I	1	0
46	28	RES	I	1	0
47	29	$\overline{WR}$	I	1	0
48	30	RD	I	1	0
49	31	SP	I	1	0
50	32	AD7	IO	3	000
51	33	AD6	IO	3	000
52	34	AD5	IO	3	000
53	35	AD4	IO	3	000
54	36	AD3	IO	3	000
55	37	AD2	IO	3	000
56	38	AD1	IO	3	000
57	39	AD0	IO	3	000
58	42	OUT31	O	2	00
59	43	OUT30	O	2	00
60	44	OUT29	O	2	00
61	45	OUT28	O	2	00
62	46	OUT27	O	2	00
63	47	OUT26	O	2	00
64	48	OUT25	O	2	00
65	49	OUT24	O	2	00
66	50	OUT23	O	2	00
67	51	OUT22	O	2	00
68	52	OUT21	O	2	00
69	53	OUT20	O	2	00
70	54	OUT19	O	2	00
71	55	OUT18	O	2	00
72	56	OUT17	O	2	00
73	57	OUT16	O	2	00

---

**Functional Description**

**Table 2**  
**Boundary Scan Sequence (cont'd)**

<b>Boundary Scan Number TDI -&gt;</b>	<b>Pin Number</b>	<b>Pin Name</b>	<b>Type</b>	<b>Number of Scan Cells</b>	<b>Default Value</b>
74	58	OUT15	O	2	00
75	59	OUT14	O	2	00
76	60	OUT13	O	2	00
77	61	OUT12	O	2	00
78	62	OUT11	O	2	00
79	63	OUT10	O	2	00
80	64	OUT9	O	2	00
81	65	OUT8	O	2	00
82	68	OUT7	O	2	00
83	69	OUT6	O	2	00
84	70	OUT5	O	2	00
85	71	OUT4	O	2	00
86	72	OUT3	O	2	00
87	73	OUT2	O	2	00
88	74	OUT1	O	2	00
89	75	OUT0	O	2	00
90	76	$\overline{\text{INT}}$	O	2	00

**2.3.2 TAP Controller**

The TAP controller implements a state machine defined in the JTAG standard IEEE1149.1. The instruction register of the controller is extended to 4 bits in order to increase the number of instructions. This is necessary for the use of the build in selftest procedure via the boundary scan interface:

**Table 3  
Instruction Code of 4 Bit TAP Controller**

<b>Instruction</b>	<b>Code</b>
EXTEST	0000
INTEST	0001
SAMPLE / PRELOAD	0010
IDCODE	0011
BYPASS	11xx
TAP_TEST1: Start built in self test	0100
TAP_TEST2: Write selftest control register	0101
TAP_TEST3	0110
TAP_TEST4	0111
TAP_TEST5	1000
TAP_TEST6	1001
TAP_TEST7	1010
TAP_TEST8	1011

The standard instructions are implemented according to the JTAG standard, just the instruction register is extended to 4 bits. At the new instructions TAP\_TEST1.. 8 special internal test signals are activated during the state "RUN TEST / IDLE".

The MTSXL only uses TAP\_TEST1 and TAP\_TEST2 according to **table 3**.

Functional Description

The extended TAP controller uses a modified data path:

**Table 4**  
**Data Path of 4 Bit TAP Controller**

Instruction Code	Input	Data Path	Output
11xx	TDI	→	TDO
00xx	BSOUT	→	TDO
0011	BSOUT_ID	→	TDO
01xx	TDI2: STAR:STOK (internal)	→	TDO
10xx	TDI3: VSS (not used, internal)	→	TDO

When TAP\_TEST1 / 2 is activated the data path is set to shift the result of the selftest procedure (bit STAR:STOK) out through the TDO pin.

**2.3.3 Use of Built in Selftest via the Boundary Scan Interface**

The built in self test is used by the following steps:

- The instruction TAP\_TEST2 is shifted into the TAP controller (see **figure 4**)
- STP command is shifted into the selftest control register (see **table 5** and **figure 5**)
- The instruction TAP\_TEST1 is shifted into the TAP controller to start the selftest (see **figure 6**) after 10240 TCK periods:
- Bit STAR:STOK can be shifted out (see **figure 7**).

**Table 5**  
**4 Bit Selftest Control Register**

Bit	Function
ST [0]	CMDR:STP0
ST [1]	CMDR:STP1
ST [2]	CMDR:STP2
ST [3]	“1” built in selftest “0” no built in selftest

*Note: ST [2:0] represent the bits CMDR:STP2..0 but do not overwrite them.*

---

**Functional Description**

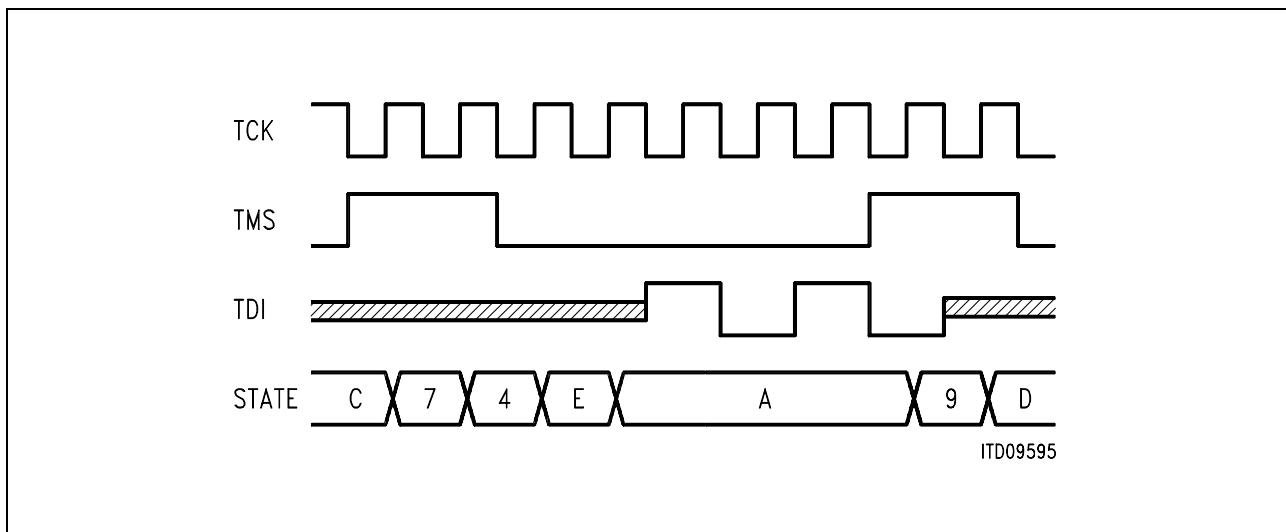
The TAP controller state machine passes through the different states according to **figures 4 to 7**.

**Table 6**  
**States of TAP Controller** (explanation for **figures 4 to 7**)

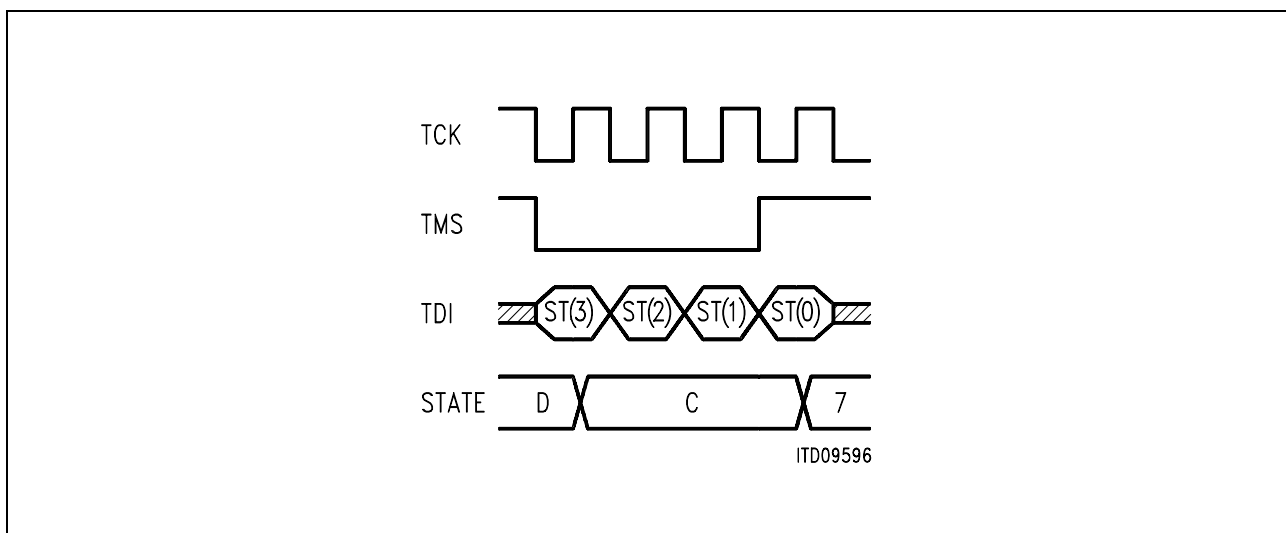
<b>Controller State</b>	<b>State Code</b>
Exit2-DR	0
Exit1-DR	1
Shift-DR	2
Pause-DR	3
Select-IR-Scan	4
Update-DR	5
Capture-DR	6
Select-DR-Scan	7
Exit2-IR	8
Exit1-IR	9
Shift-IR	A
Pause-IR	B
Run-Test / Idle	C
Update-IR	D
Capture-IR	E
Test-Logic-Reset	F

*Note: The state coding is only described for explanation purposes, it is externally not visible.*

Functional Description

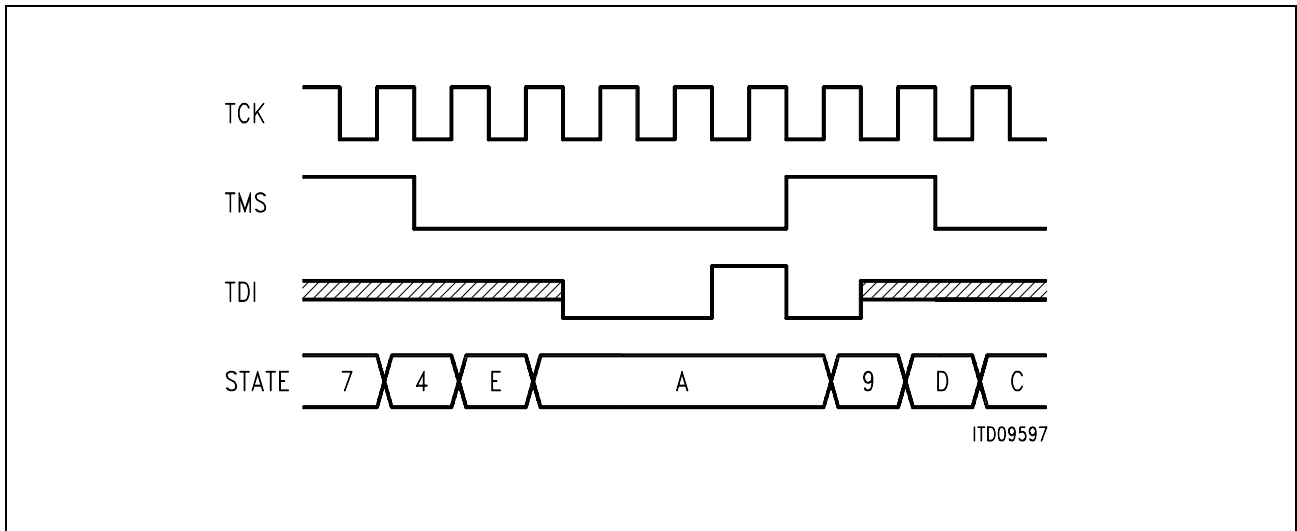


**Figure 4**  
Starting Instruction "TAP\_TEST2" (code 0101)

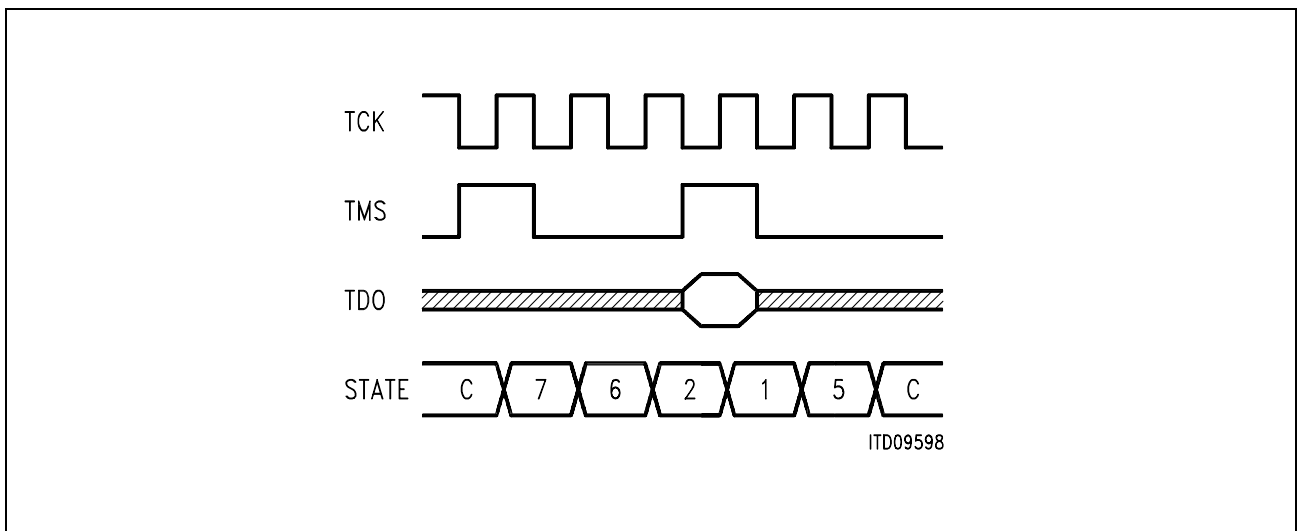


**Figure 5**  
Writing Selftest Control Register

Functional Description



**Figure 6**  
**Start of Built in Selftest (instruction TAP\_TEST1, code 0100)**



**Figure 7**  
**Readout of Selftest Result (after 10240 TCK periods)**

*Note: After the use of the selftest procedure over the  $\mu P$  Interface or the boundary scan interface a hardware reset is necessary before the selftest procedure can be started again over the other interface.*

**2.3.4 IDCODE**

The manufacturer code for MTSXL is according to **table 2:**

V1.2:	0010	0000 0000 0010 0101	0000 1000 001	1
-------	------	---------------------	---------------	---

### 3 Operational Description

#### 3.1 Initialization Procedure

For a proper initialization of the MTSXL the following procedure is recommended:

First a reset pulse (RES) of at least two CLK clock periods has to be applied. All registers contain now their reset values. In the next step the connection memories CM0/1 are initialized by the commands CMDR:STP (1:0) = 01 (CM reset) or CMDR:STP (2:0) = 011 / 111 (MTSXL selftest).

After having programmed a CM reset command, it takes 4096 clock periods until all tristate control entries in the CM contain the value "1" (tristated).

If a selftest command was given, it takes 10 240 clock periods to achieve the same effect. Furthermore the register bit STAR:STOK (selftest o.k.) should read "1" in this case, in order to prove that there is no fault on the chip. The selftest command must be given twice: the upper half of data memory (DM0, DM1) is tested when setting CMDR:STP (2:1) = 01, the lower half of DM0, DM1 is tested by setting CMDR:STP (2:1) = 11 (see **table 10**).

The activity of the procedures can be monitored in STAR:PACT and an interrupt will indicate their completion.

In all cases it is important, that the outputs are tristated by MODR:PSB = 0.

#### 3.2 Operation Mode

The operation mode of the device is fixed by programming MODR:MD (1:0) (see **table 9**).

#### 3.3 Indirect Access Registers

The connection memories and data memories are accessible through the indirect access registers MACH, MAAL, MRDH, MRDL, MWDH and MWDL. An indirect access is actually started by writing register MACH (Memory Access Address/Code Register High). The code value inherent in this register defines, what action has to be performed. The low byte of the complete access address must be programmed to MAAL (Memory Access Address Register Low) before writing to MACH. If data are necessary to perform the access (e.g. in write operations), they have to be entered into MWDH (Memory Write Data Register High) and MWDL (Memory Write Data Register Low) before. In read accesses the corresponding registers MRDH (Memory Read Data Register High) and MRDL (Memory Read Data Register Low) contain the required information after the internal read process is completed.

Operational Description

Typical Write Operation:

- WR MWDL
- WR MWDH
- WR MAAL
- WR MACH

RD STAR; STAR:MAC = 0

Typical Read Operation:

- WR MAAL
- WR MACH
- RD MRDL
- RD MRDH

RD STAR; STAR:MAC = 0

3.4 Frame Evaluation

If the device is in synchronized state (STAR:PSS = 1) and for example the command “frame evaluation at FS5” (CMDR = 58<sub>H</sub>) is programmed, the second following rising edge of FS5 is evaluated and creates the following result in register FERH:FERL (see also table 15):

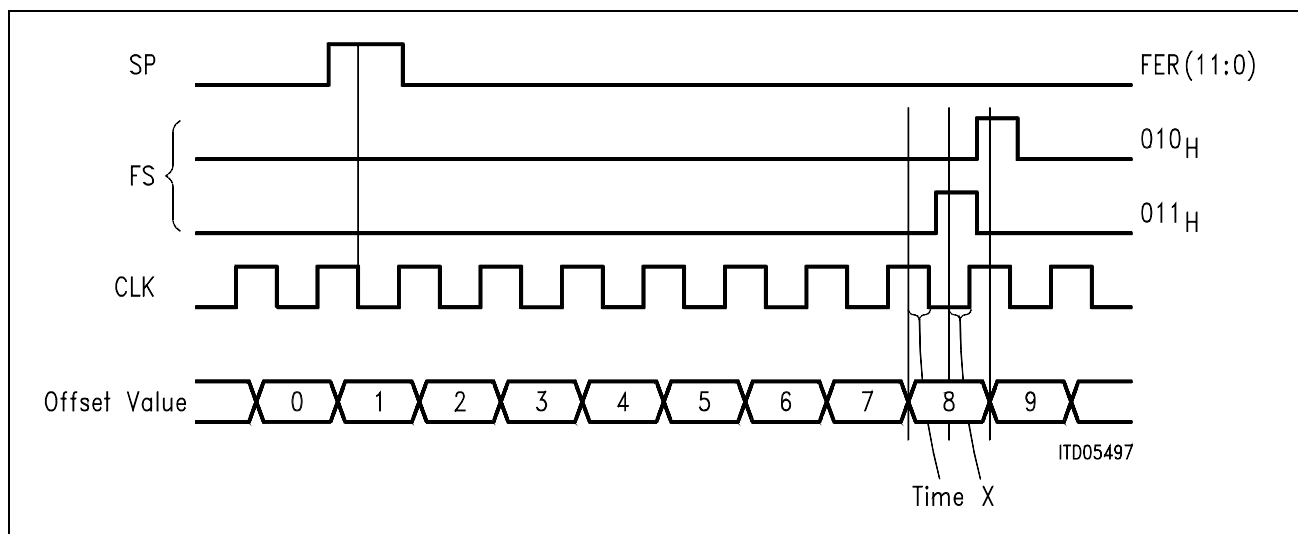


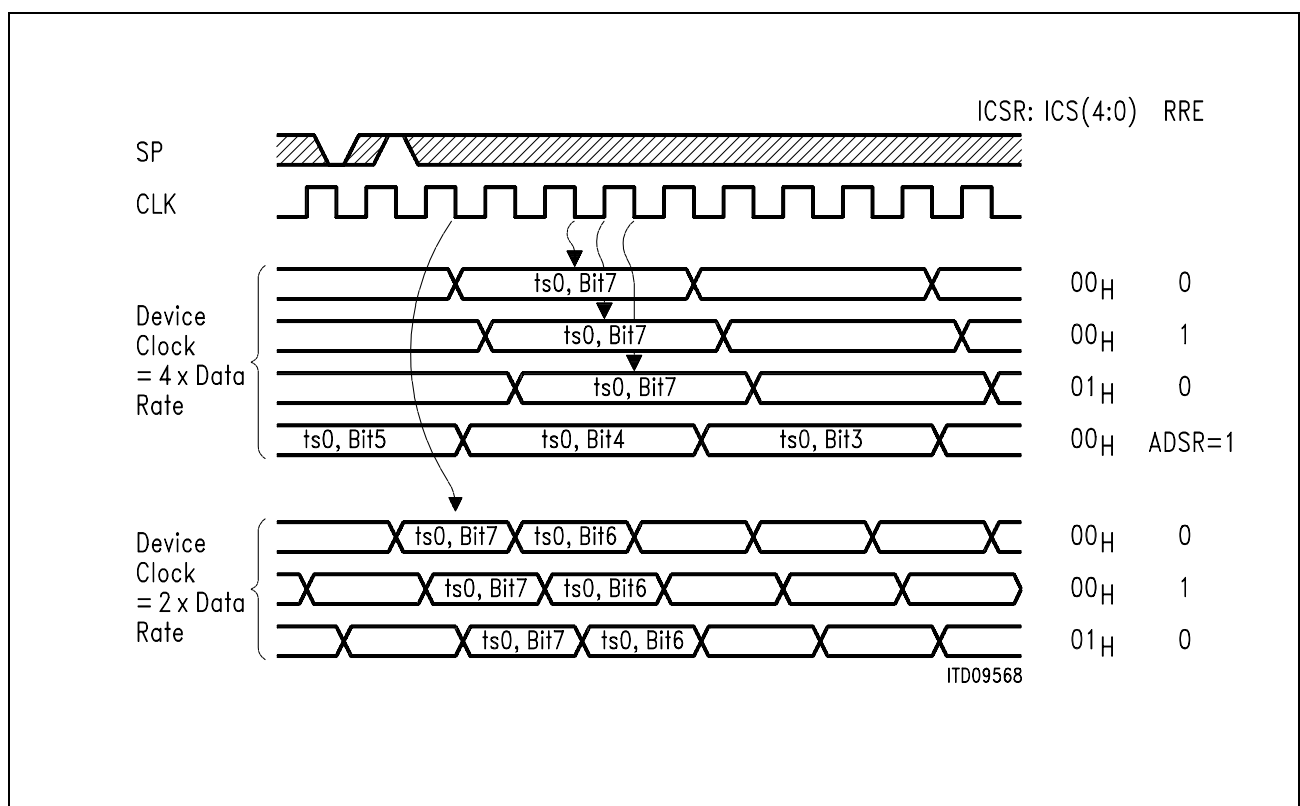
Figure 8  
Frame Evaluation

*Note: The frame evaluation procedure gives (roughly) the number to be programmed in ICSR (after inversion of FER0): FEV 11..1 give the number of complete CLK periods; FEV 0 gives the sampling edge (falling / rising). Due to the internal delay in the MTSXL the sampling region and therefor the result in FEV 11..1 is shifted against CLK for a time “X” which is uncertain between 0 < X < 13 ns. If the rising edge of FS occurs in that uncertain region the value of FER 11..1 might vary ± 1 (FER 0 inverted before!).*

### 3.5 Input Offset and Output Offset

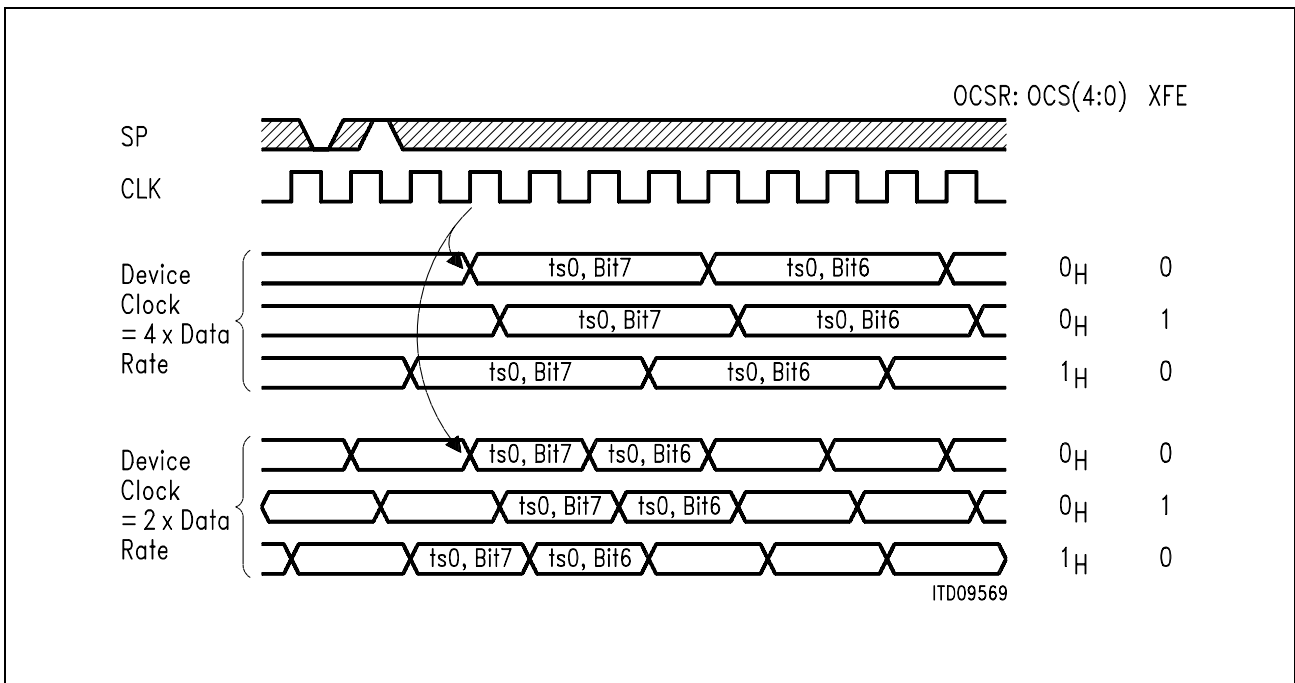
Based on the results of the frame evaluation procedures the input offsets can be adjusted by programming ICSR 7..0 corresponding to inputs IN 7..0. If data oversampling is used, the values of ICSR 7..0 can be adjusted within some limits during operation without producing bit errors:

- clockrate = 2 × datarate  
possible adjustment is one half clock period forward or backward.
- clockrate = 4 × datarate  
possible adjustment is one clock period backward or two clock periods forward.



**Figure 9**  
**Input Timing**

Operational Description

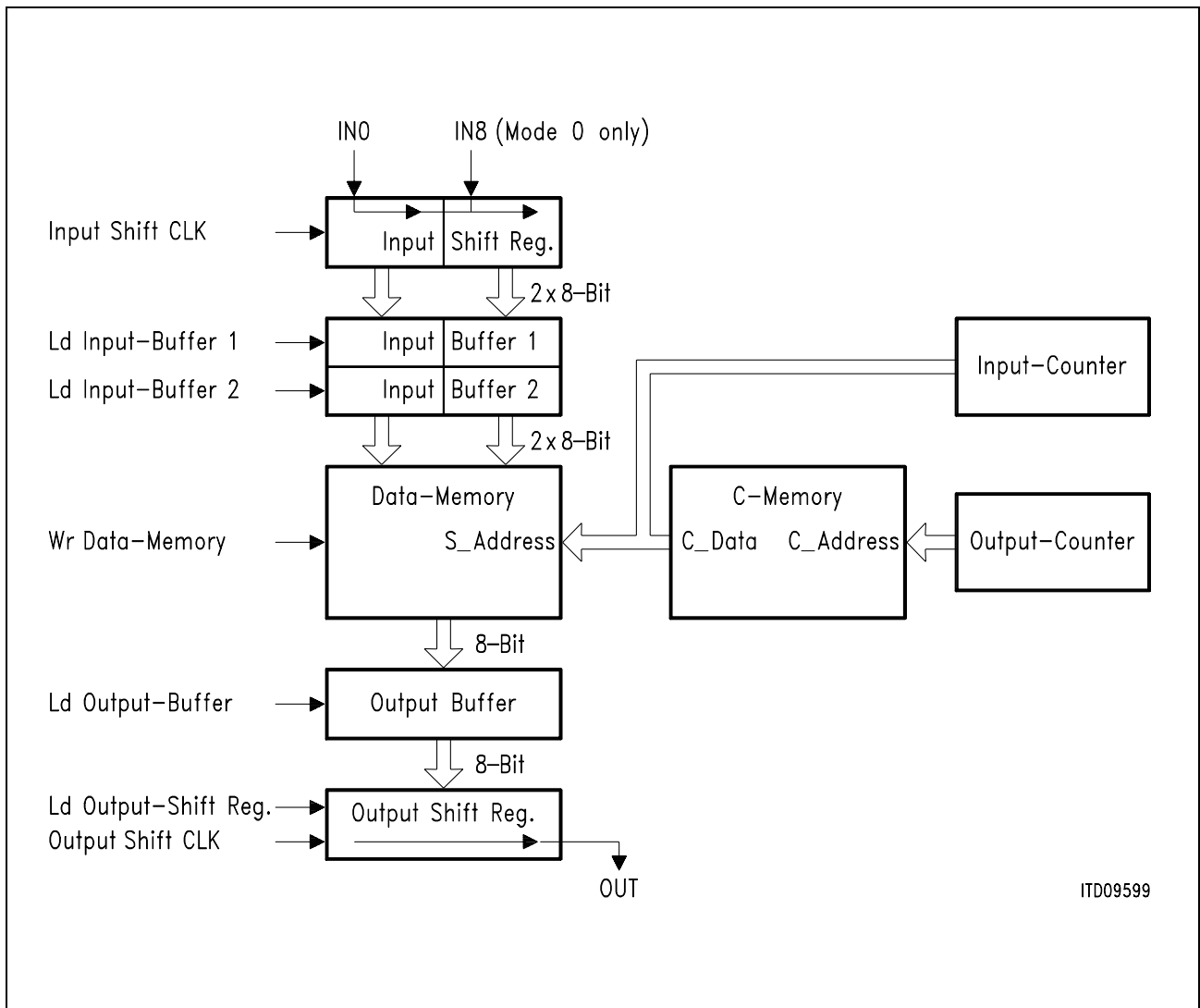


**Figure 10**  
**Output Timing**

The output offset is the same for all output lines and is fixed in register OCSR.

3.6 Frame Delay

Figure 11 shows a functional description of the Serial Input, Data Memory and Serial Output.

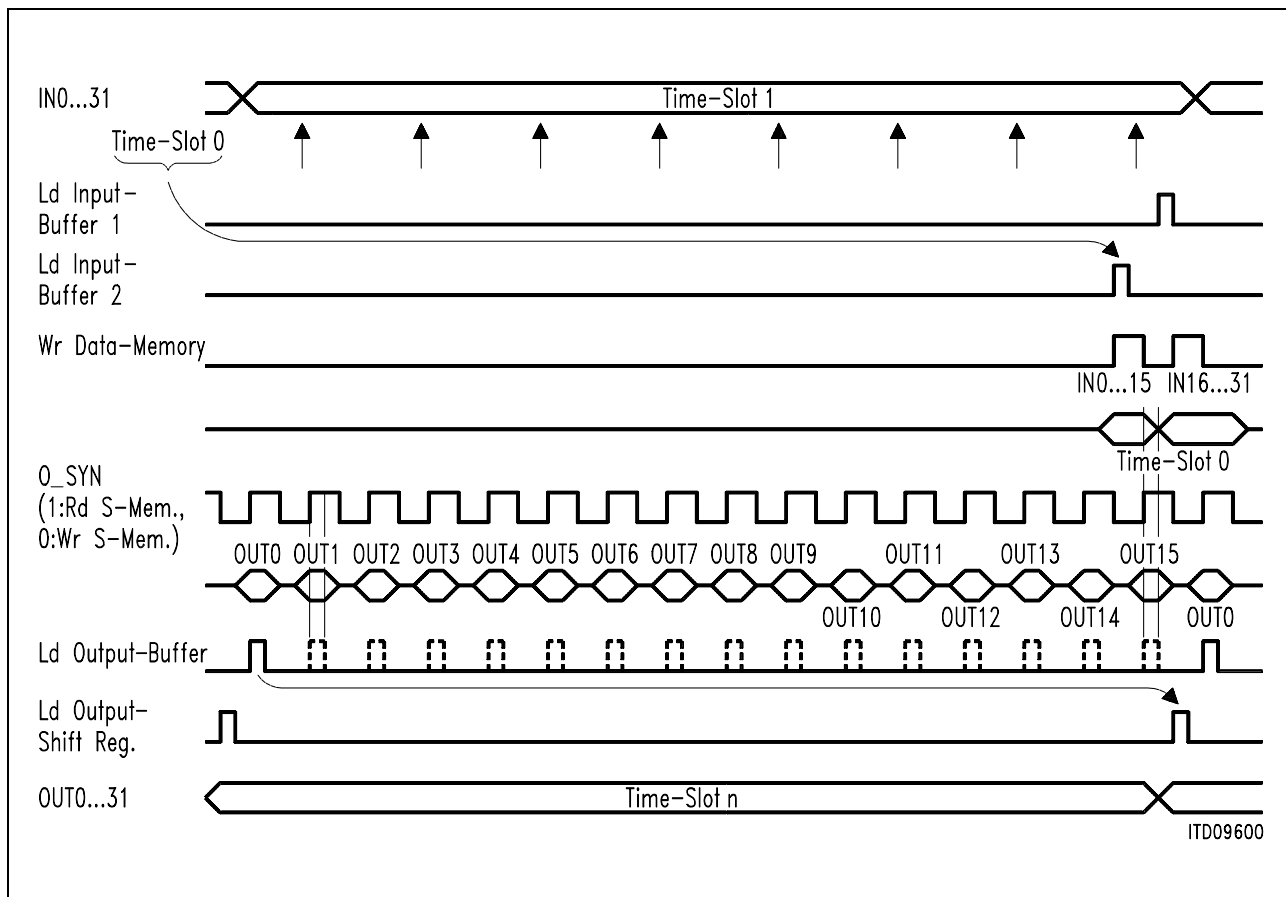


ITD09599

**Figure 11**  
**Internal Processing of Serial Data**

In mode 0 for example inputs 0 and 8 are both connected to the input shift register. In mode 1 and 3 only input 0 is used and two time slots are always processed together.

Operational Description



**Figure 12**  
**Internal Control Signals Mode 0 (OCSR = 0)**

*Note: O\_SYN is a control signal for the synchronization of RD and WR access to the data memory and not important for the external functionality. O\_SYN frequency is  $f_{CLK} / 2$ .*

This figure shows that the inputs IN0 .. IN15 are written into the data memory at the same time whereas IN16 .. IN31 are written one O\_SYN period (= 2 CLK periods) later. The value of ICSR 0..15 shifts the sampling points and the signal "Ld Inp Buffer 1" later in time (rightwards), the signals "Ld Inp Buffer 2" and "Wr S Memory" remain constant. In this example with OCSR = 0 the lower Inputs IN0 .. IN15 are written into data memory before Out15 (and Out31) is read.

With OCSR > 0 all Output Signals (Ld Outp Buffer and following) including the data (OUT0..15) on the internal data transfer bus is shifted earlier in time (leftwards). Therefore the data is read out of the data memory earlier.

Due to the internal timing the frame delay is depending on the programmed input / output time slots and OCSR. The internal delay (number of time slots) can be deduced from **figure 12** and is shown in **table 7**.

## Operational Description

If the offset of output time slot to input time slot is greater or equal to the internal delay due to **table 7** the transmission of data is within the same frame (frame delay 0).

If the offset is smaller or even negative the transmission is in the next frame (frame delay 1).

Frame delay 1 also occurs when the programmed connection overrides the frame end (TS63 in Mode 0).

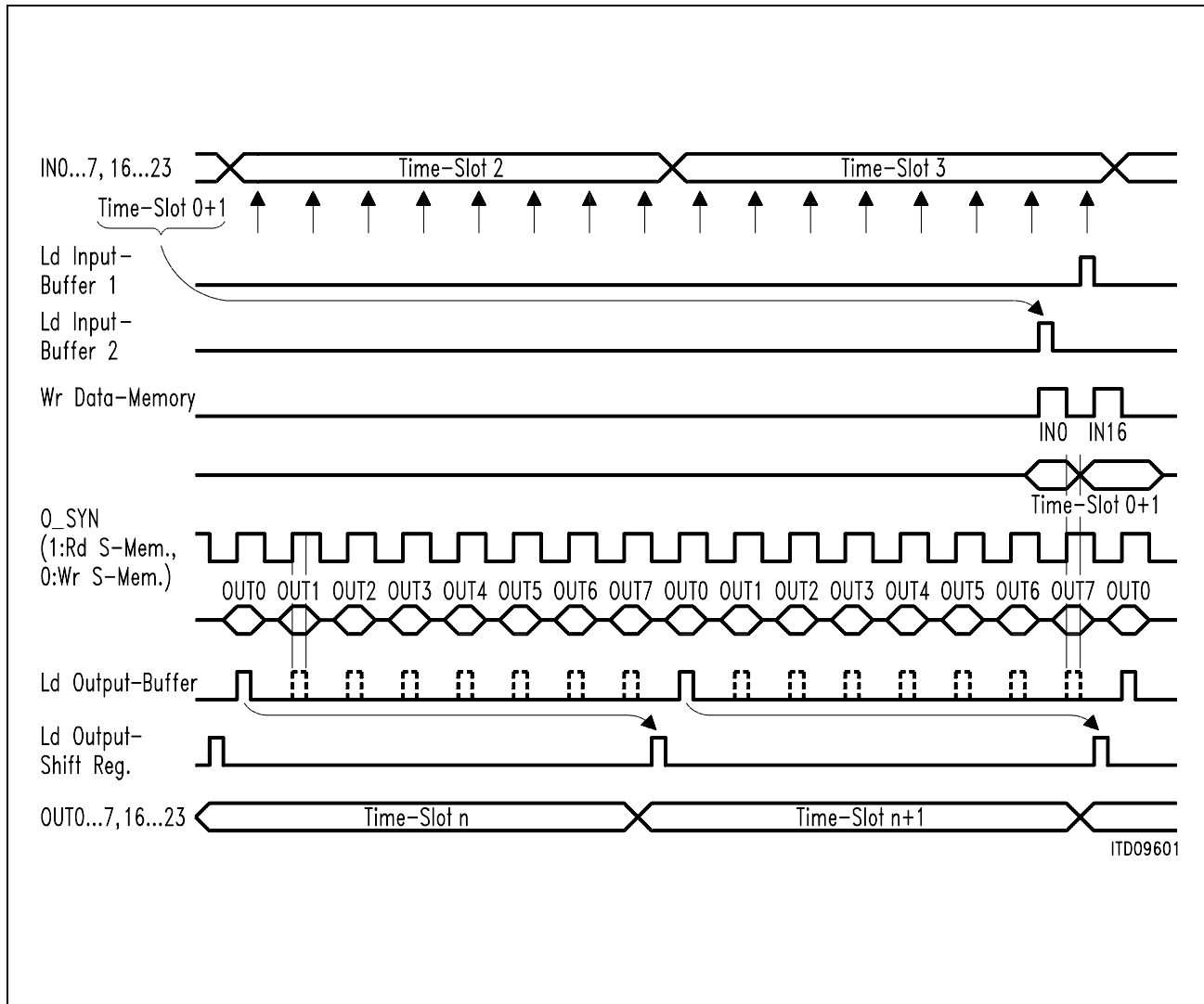
If the offset is smaller and overrides the frame end at the same time the frame delay is 2.

**Table 7**  
**Time Slots Delay Mode 0**

OCS(4:0)	IN	Outputs															
		0 16	1 17	2 18	3 19	4 20	5 21	6 22	7 23	8 24	9 25	10 26	11 27	12 28	13 29	14 30	15 31
0	0 - 15	3	3	3	3	3	3	3	3	3	3	3	3	3	3	3	2
	16 - 31	3	3	3	3	3	3	3	3	3	3	3	3	3	3	3	3
1	0 - 15	3	3	3	3	3	3	3	3	3	3	3	3	3	3	3	3
	16 - 31	4	3	3	3	3	3	3	3	3	3	3	3	3	3	3	3
2	0 - 15	4	3	3	3	3	3	3	3	3	3	3	3	3	3	3	3
	16 - 31	4	4	3	3	3	3	3	3	3	3	3	3	3	3	3	3
3	0 - 15	4	4	3	3	3	3	3	3	3	3	3	3	3	3	3	3
	16 - 31	4	4	4	3	3	3	3	3	3	3	3	3	3	3	3	3
.																	
.		Maximum delay 4 time slots															

**Examples:** Connection IN1 ts1 -> OUT1 ts 5 (Offset 4ts) : frame delay 0  
(OCSR=0) IN1 ts1 -> OUT1 ts 3 (Offset 2ts) : frame delay 1  
IN1 ts62 -> OUT31 ts 0 (Offset 2ts) : frame delay 1  
IN1 ts62 -> OUT1 ts 1 (Offset 3ts) : frame delay 2

Operational Description



**Figure 13**  
**Internal Control Signals Mode 1/3 (OCSR = 0)**

Operational Description

**Table 8**  
**Time Slot Delay Mode 1 / 3** (deduced from **figure 13**, only Input time slots 0, 2, 4,..)

OCS(4:0)	IN	Outputs								
		0 16	1 17	2 18	3 19	4 20	5 21	6 22	7 23	
0	0 - 7	5	5	5	5	5	5	5	4	
	16 - 23	5	5	5	5	5	5	5	5	
1	0 - 7	5	5	5	5	5	5	5	5	
	16 - 23	6	5	5	5	5	5	5	5	
2	0 - 7	6	5	5	5	5	5	5	5	
	16 - 23	6	6	5	5	5	5	5	5	
3	0 - 7	6	6	5	5	5	5	5	5	
	16 - 23	6	6	6	5	5	5	5	5	
.										
.		Maximum delay 6 time slots								

*Note: The time slot delays given in table 8 are valid only for even input time slots; for odd input time slots all delays have to be reduced by 1 time slots.*

## Detailed Register Description

## 4 Detailed Register Description

## 4.1 Register Address Arrangement

Reg. Name	Access	Address A4..0	Reset Value	Comment	Refer to page
MODR	RD/WR	00 <sub>H</sub>	00 <sub>H</sub>	Mode register	33
CMDR	WR	01 <sub>H</sub>	00 <sub>H</sub>	Command register	34
STAR	RD	01 <sub>H</sub>	01 <sub>H</sub>	Status register	35
ISTA	RD	02 <sub>H</sub>	00 <sub>H</sub>	Interrupt status register	36
MASK	WR	02 <sub>H</sub>	0F <sub>H</sub>	Mask register	37
MACH	RD/WR	04 <sub>H</sub>	0X <sub>H</sub>	Memory access address/code register high	37
MAAL	RD/WR	03 <sub>H</sub>	XX <sub>H</sub>	Memory access address register low	38
MRDL	RD/WR	05 <sub>H</sub>	XX <sub>H</sub>	Memory read data register low	39
MRDH	RD/WR	06 <sub>H</sub>	0X <sub>H</sub>	Memory read data register high	39
MWDL	RD/WR	07 <sub>H</sub>	XX <sub>H</sub>	Memory write data register low	39
MWDH	RD/WR	08 <sub>H</sub>	XX <sub>H</sub>	Memory write data register high	40
ICSR (15:0)	RD/WR	10 <sub>H</sub> .. 1F <sub>H</sub>	00 <sub>H</sub>	Input clock shift register bank	41
OSCR	RD/WR	0B <sub>H</sub>	00 <sub>H</sub>	Output clock shift register	42
TSTR	RD/WR	0C <sub>H</sub>	C0 <sub>H</sub>	Test register	42
FERL	RD	0E <sub>H</sub>	XX <sub>H</sub>	Frame evaluation register low	43
FERH	RD	0F <sub>H</sub>	XX <sub>H</sub>	Frame evaluation register high	43

Detailed Register Description

4.2 Mode Register (MODR)

Access in demultiplexed  $\mu$ P-interface mode:

Read/write, address: 00<sub>H</sub>

Reset value: 00<sub>H</sub>

Bit 7							Bit 0
<b>PSB</b>	<b>0</b>	<b>0</b>	<b>0</b>	<b>0</b>	<b>0</b>	<b>MD1</b>	<b>MD0</b>

**PSB**                    **PCM Stand By**; a logical 0 switches the PCM interface outputs to high impedance.

**MD1 ... MD0**        **Mode**; these bits define the chip operation mode according to the following table:

**Table 9**  
**Operation Modes**

Operation Mode	Mode Bits MD1 MD0	Input # of Ports	Input Data Rate [MHz]	Output # of Ports	Output Data Rate [MHz]
Mode 0	0 0	32	4.096	32	4.096
Mode 1	0 1	16	8.192	16	8.192
Mode 3	1 1	16	8.192	16 16 <sup>*)</sup>	8.192 8.192

*Note: <sup>\*)</sup> In mode 3 the PCM lines OUT(n+16) drive the inverted values of lines OUT(n) or are tristated, if the corresponding PCM line is tristated.*

Detailed Register Description

4.3 Command Register (CMDR)

Access in demultiplexed  $\mu$ P-interface mode:

Write, address: 01<sub>H</sub>

Reset Value: 00<sub>H</sub> (not readable)

Bit 7							Bit 0
0	FSAD2	FSAD1	FSAD0	SFE	STP2	STP1	STP0

**FSAD2..0** **Frame Synchronization** signal **Address** 2 to 0; Address of the chosen FS signal 5 to 0 to be evaluated by the procedure started by SFE.

**SFE** **Start Frame Evaluation**; a one in this bit position starts the frame evaluation procedure. A read operation on register FER will stop an unfinished frame evaluation procedure.

**STP2..0** **Start Procedure**.  
The following procedures can be activated by these bits:

Table 10  
STP Commands

STP2	STP1	STP0	Function
X	X	0	No operation
X	0	1	Start control memory reset procedure
0	1	1	Start selftest procedure (1st part)
1	1	1	Start selftest procedure (2nd part)

X: don't care

*Note: Before activating one of these procedures MODR:PSB has to be set to 0. During selftest or CM reset the device will ignore the external synchronization pulse and the user has no access to the internal data memory.*

Detailed Register Description

4.4 Status Register (STAR)

Access in demultiplexed  $\mu$ P-interface mode:

Read, address: 01<sub>H</sub>

Reset value: 01<sub>H</sub>

Bit 7							Bit 0
0	FSAD2	FSAD1	FSAD0	MAC	PACT	PSS	STOK

**FSAD2..0**      **Frame Synchronization** signal **Address:** see CMDR.

**MAC**            **Memory Access Active;** an indirect memory access is active, if this bit is “1”, all memory access registers must not be written until MAC = “0”.

**PACT**          **Procedure Active;** one of the procedures started by the  $\mu$ P (selftest, CM reset or frame evaluation) is active.

**PSS**            **PCM Synchronization Status**  
 1: the PCM interface is synchronized  
 0: the PCM interface is not synchronized. (see note in **chapter 4.5**)

**STOK**          **Selftest O.K.;** after a selftest procedure this bit is set to 1, if no faults are detected.

*Note: This bit is only valid, if no power failure or inappropriate clocking occurred during the test (see ISTA:IR); this bit is set to 1 by a start selftest command or by hardware reset.*

Detailed Register Description

4.5 Interrupt Status Register (ISTA)

Access in demultiplexed  $\mu$ P-interface mode:

Read, address: 02<sub>H</sub>

Reset value: 00<sub>H</sub>

Bit 7	0	0	0	0	FEC	PC	IR	PFI	Bit 0
-------	---	---	---	---	-----	----	----	-----	-------

**FEC**            **Frame Evaluation Completed**; the indirect register FER contains a valid offset and can be read.

**PC**            **Procedure Completed**; the procedure started from the command register (CM reset or MTSXL selftest) is finished.

**IR**            **Initialization Request**. The connection memory has to be programmed due to a loss of data (IR = 1). The IR bit is set after power failure or inappropriate clocking. It can only be retriggered again after a selftest or CM reset procedure.

**PFI**            **PCM Framing Interrupt**; this bit being logical 1 indicates the loss or gain of synchronization. Synchronization is considered lost by the MTSXL if the SP signal is not repeated within the correct period. Synchronization is considered achieved, if two consecutive SP pulses with the correct period have been received.

Any interrupt will activate the  $\overline{\text{INT}}$  line if it is not masked. All interrupt bits and the  $\overline{\text{INT}}$  line are reset when reading ISTA.

*Note 1: All interrupts and the  $\overline{\text{INT}}$  line are cleared with reset.*

*Note 2: If the SP signal is repeated within a multiple of frame length (e.g.  $2 \times$  or  $4 \times 125 \mu\text{s}$ ) but at correct phase:*

- *the MTSXL works correctly because the internal counters run autonomously and are synchronized within correct phase.*
- *the PFI interrupt does not occur because this situation is internally handled as “loss of synchronization” and this situation does not change.*

*Note 3: During selftest no PFI interrupt will occur.*

Detailed Register Description

4.6 Mask Register (MASK)

Access in demultiplexed  $\mu$ P-interface mode:

Write, address: 02<sub>H</sub>

Reset value: 0F<sub>H</sub>

Bit 7	Bit 0						
0	0	0	0	FEC	PC	IR	PFI

A logical 1 disables the corresponding interrupt as described in ISTA from activating the  $\overline{\text{INT}}$  pin. A masked interrupt (bit set to “1”) is stored internally and indicated, when reading ISTA. It is also reset in this case.

4.7 Memory Access Address/Code Register High (MACH)

Access in demultiplexed  $\mu$ P-interface mode:

Read/write, address: 04<sub>H</sub>

Reset value: 0X<sub>H</sub>

Bit 7	Bit 0						
MAC2	MAC1	MAC0	0	0	MA10	MA9	MA8

A write access (rising edge of  $\overline{\text{WR}}$  or  $\overline{\text{CS}}$ ) to this register starts an indirect access to a memory location.

**MAC2..0** Memory Access Code values to determine the type of access to/from control and data memory locations. See **table 11** for all possible code values.

**Table 11**  
**Memory Access Codes**

MAC2	MAC1	MAC0	Function	Max. Access Time Clock Periods
0	0	0	No operation	–
0	0	1	Write control memory	4.5
0	1	1	Write & read control memory	6.5
0	1	0	Read control memory	4.5
1	0	0	Read data memory	8.5
All other combinations are not allowed				

*Note: A write & read control memory command actually writes a specific CM location and reads the same location in a second access.*

**MA10..8** Memory Address (most significant) bits 10 to 8; refer to register MAAL

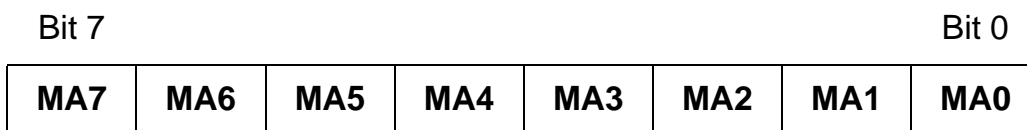
Detailed Register Description

4.8 Memory Access Address Register Low (MAAL)

Access in a demultiplexed  $\mu$ P-interface mode:

Read/write, address: 03<sub>H</sub>

Reset value: XX<sub>H</sub>



**MA7..0** Memory Address bits 7 to 0; the complete memory address is the concatenation of MA10..0.

If the value MA(10:0) is used as a control memory address, each address corresponds to a single output time slot (see **table 12**):

**Table 12**  
**Output Time Slot Mapping**

Mode		Valid for Output (Ports)																						
0	<table border="1" style="width: 100%; text-align: center;"> <tr> <td style="width: 12.5%;">MA10</td><td style="width: 12.5%;">MA9</td><td style="width: 12.5%;">MA8</td><td style="width: 12.5%;">MA7</td><td style="width: 12.5%;">MA6</td><td style="width: 12.5%;">MA5</td><td style="width: 12.5%;">MA4</td><td style="width: 12.5%;">MA3</td><td style="width: 12.5%;">MA2</td><td style="width: 12.5%;">MA1</td><td style="width: 12.5%;">MA0</td> </tr> <tr> <td colspan="6">Time Slot Number</td> <td colspan="5">Port Number</td> </tr> </table>	MA10	MA9	MA8	MA7	MA6	MA5	MA4	MA3	MA2	MA1	MA0	Time Slot Number						Port Number					OUT (31:0) = Port (31:0)
MA10	MA9	MA8	MA7	MA6	MA5	MA4	MA3	MA2	MA1	MA0														
Time Slot Number						Port Number																		
1	<table border="1" style="width: 100%; text-align: center;"> <tr> <td style="width: 12.5%;">MA10</td><td style="width: 12.5%;">MA9</td><td style="width: 12.5%;">MA8</td><td style="width: 12.5%;">MA7</td><td style="width: 12.5%;">MA6</td><td style="width: 12.5%;">MA5</td><td style="width: 12.5%;">MA4</td><td style="width: 12.5%;">MA3</td><td style="width: 12.5%;">MA2</td><td style="width: 12.5%;">MA1</td><td style="width: 12.5%;">MA0</td> </tr> <tr> <td colspan="6">Time Slot Number6..1</td> <td>PN3</td><td>TS0</td><td colspan="3">PN2..0</td> </tr> </table>	MA10	MA9	MA8	MA7	MA6	MA5	MA4	MA3	MA2	MA1	MA0	Time Slot Number6..1						PN3	TS0	PN2..0			OUT (7:0) = Port (7:0) OUT (23:16) = Port (15:8)
MA10	MA9	MA8	MA7	MA6	MA5	MA4	MA3	MA2	MA1	MA0														
Time Slot Number6..1						PN3	TS0	PN2..0																
3	<table border="1" style="width: 100%; text-align: center;"> <tr> <td style="width: 12.5%;">MA10</td><td style="width: 12.5%;">MA9</td><td style="width: 12.5%;">MA8</td><td style="width: 12.5%;">MA7</td><td style="width: 12.5%;">MA6</td><td style="width: 12.5%;">MA5</td><td style="width: 12.5%;">MA4</td><td style="width: 12.5%;">MA3</td><td style="width: 12.5%;">MA2</td><td style="width: 12.5%;">MA1</td><td style="width: 12.5%;">MA0</td> </tr> <tr> <td colspan="6">Time Slot Number6..1</td> <td>PN3</td><td>TS0</td><td colspan="3">PN2..0</td> </tr> </table>	MA10	MA9	MA8	MA7	MA6	MA5	MA4	MA3	MA2	MA1	MA0	Time Slot Number6..1						PN3	TS0	PN2..0			OUT (7:0) = Port (7:0) = <u>Port (15:8)</u> OUT (23:16) = Port (15:8) = <u>Port (31:24)</u>
MA10	MA9	MA8	MA7	MA6	MA5	MA4	MA3	MA2	MA1	MA0														
Time Slot Number6..1						PN3	TS0	PN2..0																

*Note:  $\overline{Port(m)}$  means, that this port drives the inverted data values of port (m-8). For the operation "Read Data Memory" MA10..0 are used as data memory addresses with the same mapping to the input time slots as listed in the above table.*

Detailed Register Description

**4.9 Memory Read Data Register Low (MRDL)**

Access in demultiplexed  $\mu$ P-interface mode:

Read/write, address: 05<sub>H</sub>

Reset value: XX<sub>H</sub>

Bit 7							Bit 0
<b>MRD7</b>	<b>MRD6</b>	<b>MRD5</b>	<b>MRD4</b>	<b>MRD3</b>	<b>MRD2</b>	<b>MRD1</b>	<b>MRD0</b>

**MRD7..0** Memory Read Data values (bits 7 to 0); see MRDH;

**4.10 Memory Read Data Register High (MRDH)**

Access in demultiplexed  $\mu$ P-interface mode:

Read/write, address: 06<sub>H</sub>

Reset value: 0X<sub>H</sub>

Bit 7							Bit 0
<b>0</b>	<b>0</b>	<b>0</b>	<b>0</b>	<b>MRD11</b>	<b>MRD10</b>	<b>MRD9</b>	<b>MRD8</b>

**MRD11..8** Memory Read Data values (bits 11 to 8); in a read memory access the requested values can be read in these registers after the access time (see **table 11**). An active access cycle, started by a write access to MACH, is indicated by register bit STAR:MAC.

**4.11 Memory Write Data Register Low (MWDL)**

Access in demultiplexed  $\mu$ P-interface mode:

Read/write, address: 07<sub>H</sub>

Reset value: XX<sub>H</sub>

Bit 7							Bit 0
<b>MWD7</b>	<b>MWD6</b>	<b>MWD5</b>	<b>MWD4</b>	<b>MWD3</b>	<b>MWD2</b>	<b>MWD1</b>	<b>MWD0</b>

**MWD7..0** Memory Write Data values (bits 7 to 0); see MWDH;

Detailed Register Description

4.12 Memory Write Data Register High (MWDH)

Access in demultiplexed  $\mu$ P-interface mode:

Read/write, address: 08<sub>H</sub>

Reset value: XX<sub>H</sub>

Bit 7	0	0	0	0	MWD11	MWD10	MWD9	MWD8	Bit 0
-------	---	---	---	---	-------	-------	------	------	-------

**MWD11..8**      **Memory Write Data** values (bits 11 to 8); in a write memory access the values to transfer are written to these registers. Both registers must not be written during an active access. An active access cycle, started by a write access to MACH, is indicated by register bit STAR:MAC.

If the values MWD10..0 / MRD10..0 are used as control memory entries, each possible value corresponds to a single input time slot. MWD11 / MRD11 defines, whether the input time slot is switched actively to the PCM output or is switched to high impedance.

**Table 13**  
**Input Time Slot Mapping / Programming of Output Tristate Control**

Mode	MRD11..0 / MWD11..0											Valid for Inputs/(Ports)	
0	D11	D10	D9	D8	D7	D6	D5	D4	D3	D2	D1	D0	IN (31:0) = Port (31:0)
	$\overline{TSC}$	Time Slot Number						Port Number					
1, 3	D11	D10	D9	D8	D7	D6	D5	D4	D3	D2	D1	D0	IN (23:16) = Port (15:8) IN (7:0) = Port (7:0)
	$\overline{TSC}$	Time Slot Number 6..1						PN3	TS0	PN2..0			

**TSC**      **Tristate Control Value**  
 0: active  
 1: high impedance;  
 TSC controls whether the output time slot (corresponding to the address of the control memory location) will drive the PCM values or will be tristate.

Detailed Register Description

4.13 Input Clock Shift Register Bank ICSR (15:0)

Access in demultiplexed  $\mu$ P-interface mode:

Read/write, address: 10<sub>H</sub>...1F<sub>H</sub>

Reset value: 00<sub>H</sub>

Bit 7	Bit 0
ADRS	RRE
0	ICS0
ICS4	ICS1
ICS3	ICS2

**ADRS** **Add Shift Register**; a three bit shift register is inserted into the corresponding input(s), resulting in an additional offset for that/those input(s). The sampling point is shifted “backwards” by 3 clock cycles (see **figure 9**).

*Note: ADRS has to be set to “0” in modes 1 and 3.*

**ICS4..0** Input Clock Shift; the value of ICS4..0 determines the number of clock cycles by which the bit sampling point is shifted forward in all input modes according to **figure 9**.

**RRE** **Receive on Rising Edge**; the PCM data of the corresponding input(s) is sampled with the rising edge of the clock, if this bit is set.

These 16 registers determine the individual clock shift of inputs IN0 to IN15. If more than sixteen inputs are used, two inputs are controlled by one ICSR register:

ICSR0	controls	IN0, IN8
ICSR1	”	IN1, IN9
ICSR2	”	IN2, IN10
.	.	.
.	.	.
ICSR7	”	IN7, IN15
ICSR8	”	IN16, IN24
ICSR9	”	IN17, IN25
ICSR10	”	IN18, IN16
.	.	.
.	.	.
ICSR15	”	IN23, IN31

The values of ICSR (15:0) can be adjusted without producing bit errors:

- clockrate = 2 × datarate  
possible adjustment is one half clock period forward or backward.
- clockrate = 4 × datarate  
possible adjustment is one clock period backward or two clock periods forward.

Detailed Register Description

4.14 Output Clock Shift Register (OSCR)

Access in demultiplexed  $\mu$ P-interface mode:

Read/write, address: 0B<sub>H</sub>

Reset value: 00<sub>H</sub>

Bit 7	Bit 0						
VN1	VN0	OCS4	OCS3	OCS2	OCS1	OCS0	XFE

**VN1..0**      **Version Number** according to the table below:  
(read only)

**Table 14**    **Version Number**

VN 1	VN 0	Device Versions
0	1	A1 (V1.2)

**OCS4..0**      **Output Clock Shift**; these values determine the offset of the output data relative to the SP frame according to **figure 10**.

**XFE**            **Transmit on Falling Edge**  
 0: output data is transmitted with the rising edge of the clock.  
 1: output data is transmitted with the falling edge of the clock.

4.15 Test Register (TSTR)

Access in demultiplexed  $\mu$ P-interface mode:

Read/write, address: 0C<sub>H</sub>

Reset value: C0<sub>H</sub>

Bit 7	Bit 0						
STOK1	STOK0	0	0	0	0	0	DOA
└──────────┘							
read only							

**STOK1..0**      **Selftest OK Data Memory**; these bits are “ANDed” for STAR:STOK and can be used for analysis.

**DOA**            **Direct Output Addressing**; if this bit is set to “1” the PCM outputs are not switched from the PCM inputs. Instead the 8 LSB’s programmed to the connection memory are used as data bits, which are shifted out of the corresponding output time slot. The programmed tristate control value keeps its function as in normal operation mode.

Detailed Register Description

4.16 Frame Evaluation Register Low (FERL)

Access in a demultiplexed  $\mu$ P-interface mode:

Read, address:  $0E_H$

Reset value:  $XX_H$

Bit 7							Bit 0
<b>FEV7</b>	<b>FEV6</b>	<b>FEV5</b>	<b>FEV4</b>	<b>FEV3</b>	<b>FEV2</b>	<b>FEV1</b>	<b>FEV0</b>

**FEV7..0** Frame Evaluation Values (bits 7 to 0); refer to FERH;

4.17 Frame Evaluation Register High (FERH)

Access in demultiplexed  $\mu$ P-interface mode:

Read, address:  $0F_H$

Reset value:  $XX_H$

Bit 7							Bit 0
<b>0</b>	<b>0</b>	<b>0</b>	<b>0</b>	<b>FEV11</b>	<b>FEV10</b>	<b>FEV9</b>	<b>FEV8</b>

**FEV11..0** **Frame Evaluation Values**; after a frame evaluation procedure (interrupt ISTA:FEC) these two registers contain the offset between the SP frame and an evaluated FS0 ... FS5 frame. The evaluation is performed at the second following rising edge of FS after the command CMDR:SFE = 1 was programmed.

*Note: The device must be synchronized to SP (STAR: PSS = 1) in order to generate a correct result in FERL / FERH.*

**Table 15**  
**Frame Evaluation Register**

CLK / 1.024 MHz	Offset Value = FEV11..1	FEV0	FS Rising Edge between
16	Number of clock periods +1	0	Clock rising edge-X ns and clock falling edge-X ns
	Number of clock periods +1	1	Clock falling edge-X ns and clock rising edge-X ns

*Note: Time constant "X" is specified to 0 ns < X < 13 ns (see figure 8)*

## Electrical Characteristics

## 5 Electrical Characteristics

**Table 16**  
**Absolute Maximum Ratings**

Parameter	Symbol	Limit Values	Unit
Ambient temperature under bias	$T_A$	0 to 70	°C
Storage temperature	$T_{stg}$	– 65 to 150	°C
Supply voltage	$V_{DD}$	– 0.3 to 7.0	V
Input voltage	$V_I$	– 0.3 to $V_{DD} + 0.3$ (max 7)	V
Output voltage	$V_O$	– 0.3 to $V_{DD} + 0.3$ (max 7)	V

*Note: Stresses above those listed under “Absolute Maximum Ratings” may cause permanent damage to the device. Exposure to conditions beyond those indicated in recommended operational conditions of this specification may affect device reliability.*

**Table 17**  
**DC Characteristics**

Ambient temperature under bias range;  $V_{DD} = 5\text{ V} \pm 5\%$ ,  $V_{SS} = 0\text{ V}$

Parameter	Symbol	Limit Values		Unit	Test Condition
		min.	max.		
L-input voltage	$V_{IL}$	– 0.4	0.8	V	
H-input voltage	$V_{IH}$	2.0	$V_{DD} + 0.4$	V	
L-output voltage	$V_{OL}$		0.45	V	$I_{OL} = 2\text{ mA}$
H-output voltage	$V_{OH}$	2.4		V	$I_{OH} = -400\text{ }\mu\text{A}$
H-output voltage	$V_{OH}$	$V_{DD} - 0.5$		V	$I_{OH} = -100\text{ }\mu\text{A}$
Operational power supply current	$I_{CC}$		100	mA	$V_{DD} = 5\text{ V}$ , inputs at 0 V or $V_{DD}$ , no output loads $f_{CLK} = 16.384\text{ MHz}$
Input leakage current	$I_{LI}$		1	$\mu\text{A}$	$0\text{ V} < V_{IN} < V_{DD}$ to 0 V
Output leakage current	$I_{LO}$		1	$\mu\text{A}$	$0\text{ V} < V_{OUT} < V_{DD}$ to 0 V

Electrical Characteristics

**Table 18**  
**Capacitances**

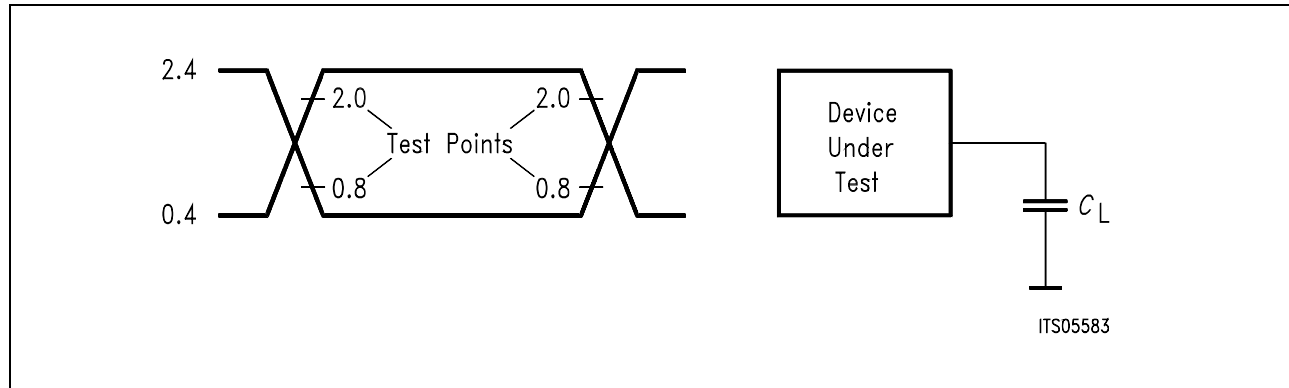
$T_A = 25\text{ }^\circ\text{C}$ ,  $V_{DD} = 5\text{ V} \pm 5\%$ ,  $V_{SS} = 0\text{ V}$

Parameter	Symbol	Limit Values		Unit
		min.	max.	
Input capacitance	$C_{IN}$		5	pF
Output capacitance	$C_{OUT}$		10	pF
I/O capacitance	$C_{IO}$		15	pF

**AC Characteristics**

Ambient temperature under bias range,  $V_{DD} = 5\text{ V} + 5\%$ .

Inputs are driven at 2.4 V for a logical 1 and at 0.4 V for a logical 0. Timing measurements are made at 2.0 V for a logical 1 and at 0.8 V for a logical 0. The AC testing input/output waveforms are shown below. Timing values are guaranteed for capacitive loading of  $C_L = 60\text{ pF}$  on all outputs except pins D(7:0), which are specified for  $C_L = 100\text{ pF}$ .

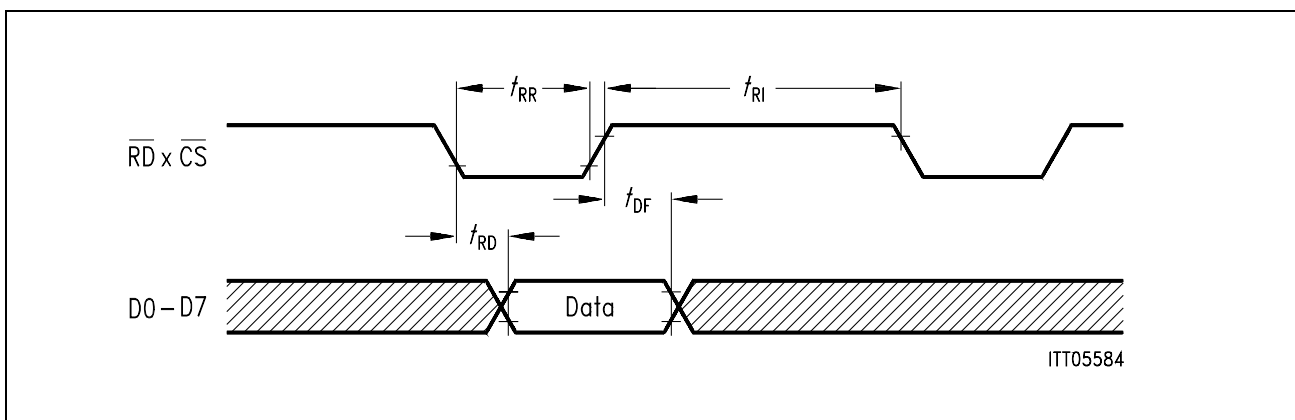


**Figure 14**  
**I/O Waveform for AC Tests**

Electrical Characteristics

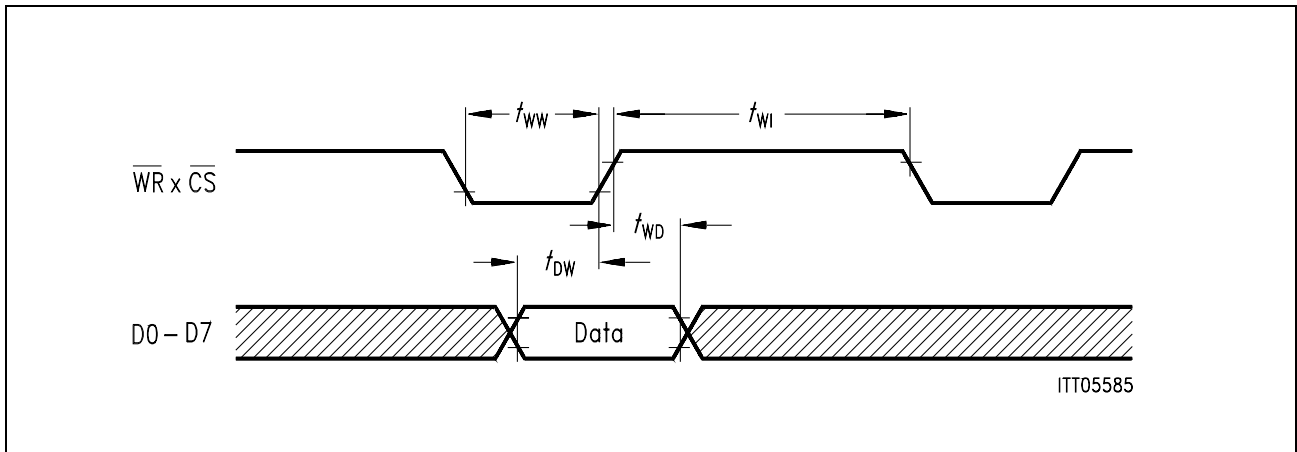
**Table 19**  
**μP Interface Timing Parameters**

Parameter	Symbol	Limit Values		Unit
		min.	max.	
Address setup time to $\overline{WR}$ , $\overline{RD}$	$t_{AS}$	10		ns
Address hold time from $\overline{WR}$ , $\overline{RD}$	$t_{AH}$	0		ns
$\overline{RD}$ pulse width	$t_{RR}$	120		ns
Data output delay from $\overline{RD} \times \overline{CS}$	$t_{RD}$		100	ns
Data float from $\overline{RD}$	$t_{DF}$		25	ns
$\overline{RD}$ control interval	$t_{RI}$	70		ns
$\overline{WR}$ pulse width	$t_{WW}$	60		ns
Data setup time to $\overline{WR} \times \overline{CS}$	$t_{DW}$	30		ns
Data hold time from $\overline{WR} \times \overline{CS}$	$t_{WD}$	10		ns
$\overline{WR}$ control interval	$t_{WI}$	70		ns
$\overline{INT}$ activation delay	$t_{ID}$		100	ns
$\overline{INT}$ activation/deactivation delay from $\overline{RD}$ , $\overline{WR}$	$t_{IID}$		120	ns

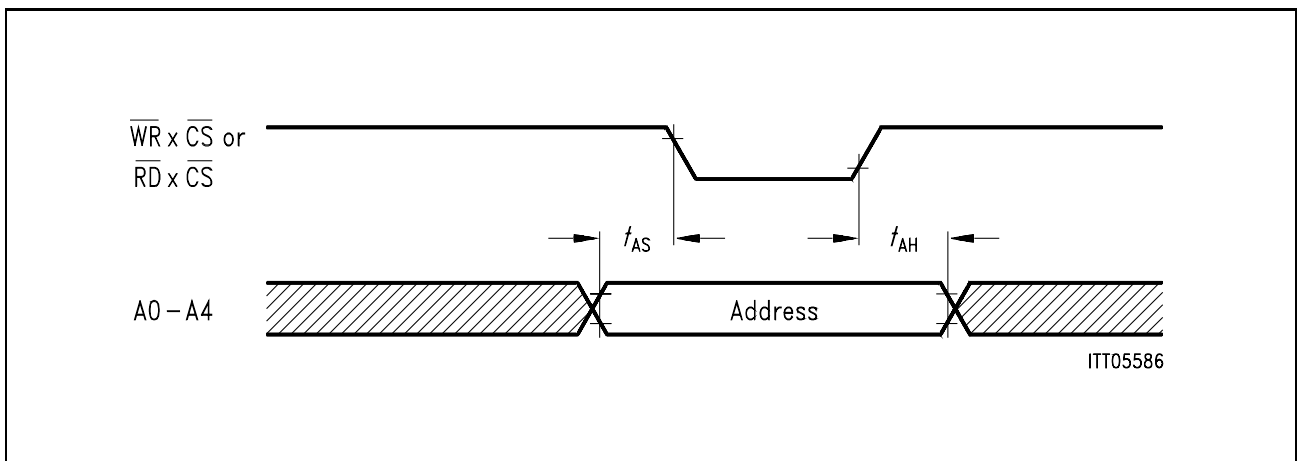


**Figure 15**  
**μP Read Cycle**

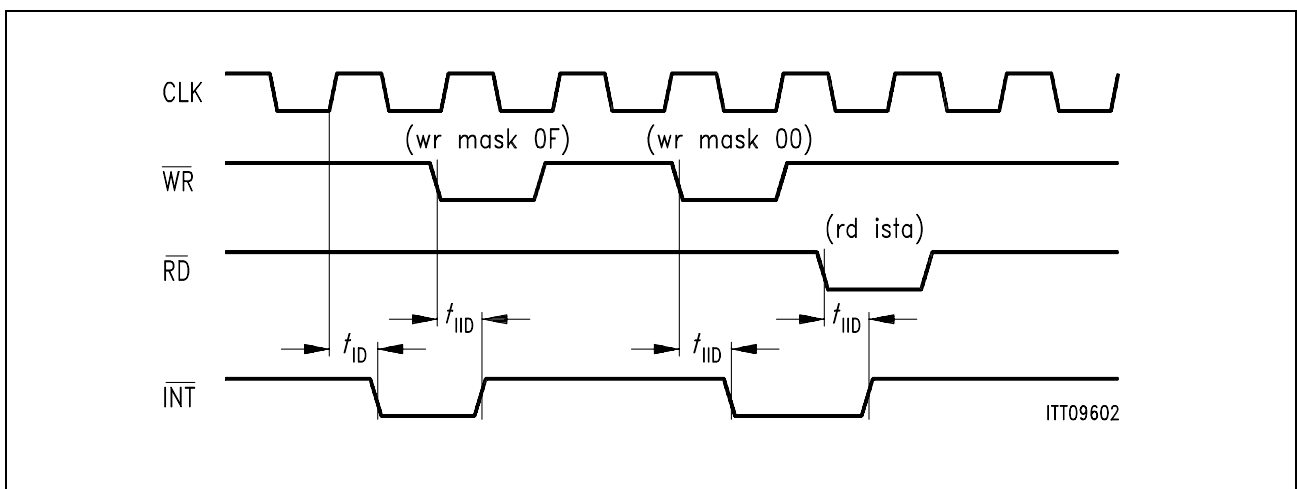
Electrical Characteristics



**Figure 16**  
**μP Write Cycle**



**Figure 17**  
**Demultiplexed Address Timing**



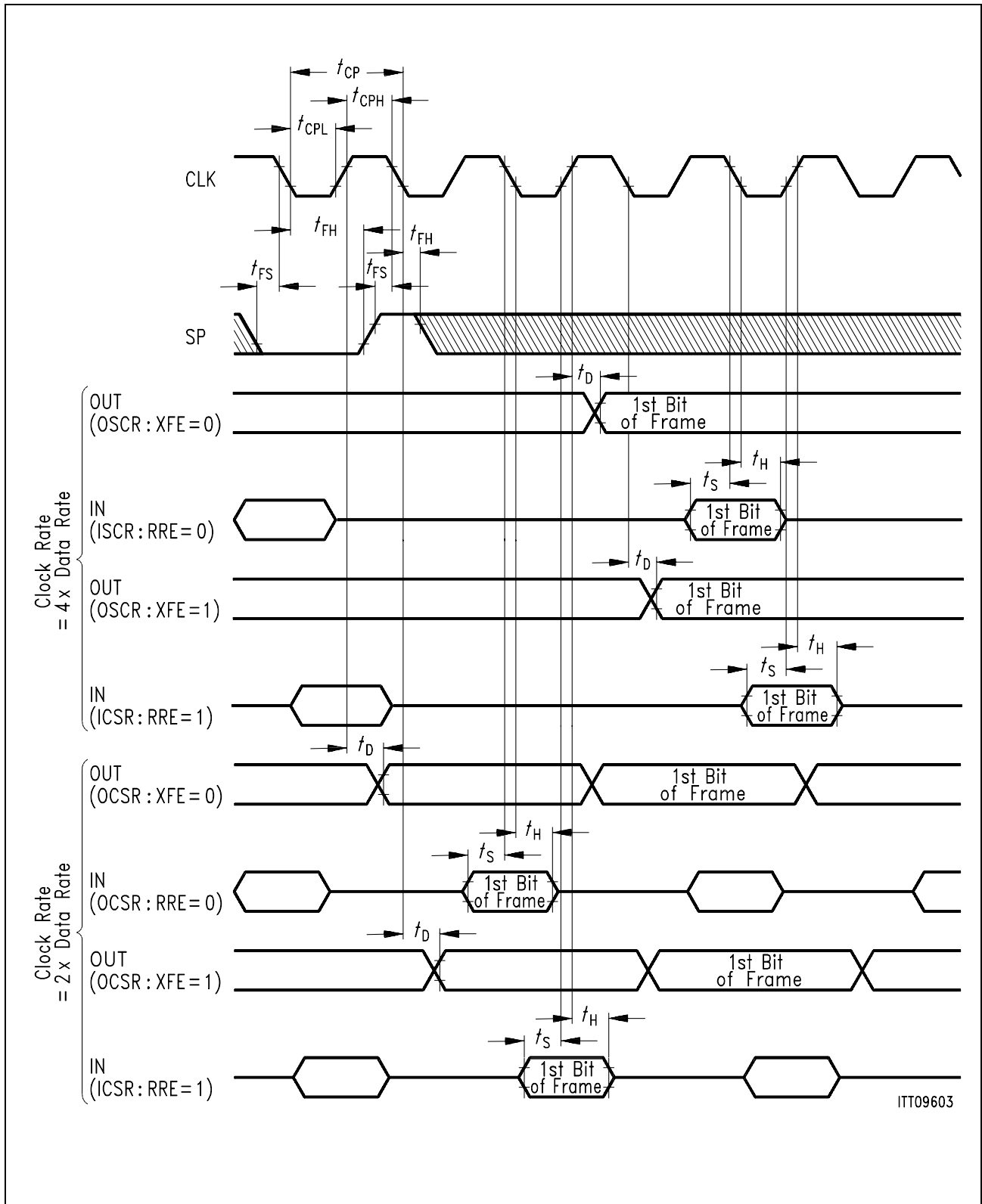
**Figure 18**  
**Interrupt Timing**

## Electrical Characteristics

**Table 20 PCM Interface Characteristics**

Parameter	Symbol	Limit Values		Unit	Condition
		min.	max.		
Clock period	$t_{CP}$	60		ns	
Clock period low	$t_{CPL}$	27		ns	
Clock period high	$t_{CPH}$	27		ns	
Frame setup time	$t_{FS}$	7		ns	
Frame hold time	$t_{FH}$	20		ns	
Serial data input setup time	$t_S$	9		ns	
Serial data input hold time	$t_H$	20		ns	
PCM serial data output delay time	$t_D$		50	ns	

Electrical Characteristics

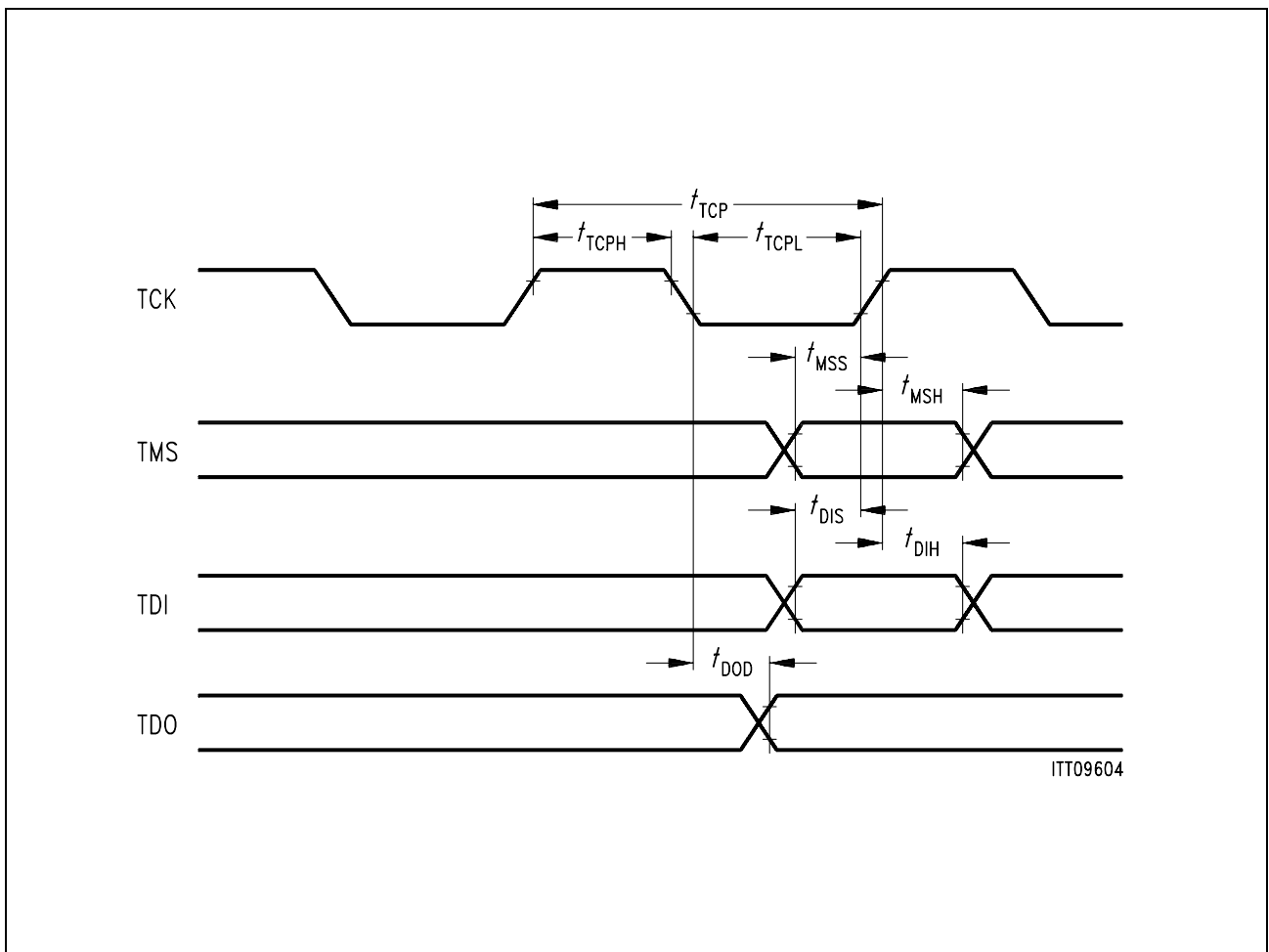


**Figure 19**  
AC Characteristics at the PCM Interface

Electrical Characteristics

**Table 21**  
**Boundary Scan Timing**

Parameter	Symbol	Limit Values		Unit	Condition
		min.	max.		
Test clock period	$t_{TCP}$	160		ns	
Test clock period low	$t_{TCPL}$	80		ns	
Test clock period high	$t_{TCPH}$	80		ns	
TMS setup time to TCK	$t_{MSS}$	30		ns	
TMS hold time from TCK	$t_{MSH}$	30		ns	
TDI setup time to TCK	$t_{DIS}$	30		ns	
TDI hold time from TCK	$t_{DIH}$	30		ns	
TDO delay from TCK	$t_{DOD}$		60	ns	



**Figure 20**  
**AC Characteristics at Boundary Scan Interface**

