

Dual Full-Bridge PWM Motor Driver

AM2916

The AM2916 motor driver is designed to drive both windings of a bipolar stepper motor or to control bidirectionally two DC motors. Both bridges are capable of sustaining 45V and include internal pulse-width modulation (PWM) control of the output current to 750mA. The outputs have been optimized for a low output saturation voltage drop (less than 1.8V total source plus sink at 500mA).

For PWM current control, the maximum output current is determined by the user's selection of a reference voltage and sensing resistor. Two logic-level inputs select output current limits of 0, 33%, 67%, or 100% of the maximum level. A PHASE input to each bridge determines load current direction.

The bridges include both ground clamp and fly-back diodes for protection against inductive transients. Internally generated delays prevent cross-over currents when switching current direction. Special power-up sequencing is not required. A thermal protection circuitry disables the outputs if the chip temperature exceeds safe operating limits.

The AM2916 is supplied in a 24-lead surface-mountable SOIC. Its batwing construction provides for maximum package power dissipation in the smallest possible construction.

● Applications

Scanner

● Features

- 1) 750mA continuous output current
- 2) 45V output sustaining voltage
- 3) Internal clamp diodes
- 4) Internal PWM current control
- 5) Low output saturation voltage
- 6) Internal thermal shutdown circuitry

● Absolute Maximum Ratings at $T_J \leq 150^\circ\text{C}$

Parameter	Symbol	Limits	Unit
Motor supply voltage	V_{BB}	45	V
Output current	Peak	+1.0	A
	Continuous	+750	mA
Logic supply voltage	V_{CC}	7.0	V
Logic input voltage range	V_{IN}	-0.3 ~ +7.0	V
Output emitter voltage	V_{SENSE}	1.5	V
Package power dissipation	P_D	55	$^\circ\text{C}/\text{W}$
Operating temperature range	T_A	-20 ~ +85	$^\circ\text{C}$
Storage temperature range	T_S	-55 ~ +150	$^\circ\text{C}$

*Output current rating may be limited by duty cycle, ambient temperature, and heat sinking. Under any set of conditions, do not exceed the specified peak current rating or a junction temperature of +150 $^\circ\text{C}$.

● **Thermal Data**

Description	Symbol	Value	Unit
Thermal Resistance Junction-case	R _{thjc}	20	°C/W
Thermal Resistance Junction-ambient	R _{thja}	76	°C/W

*With minimized copper area.

● **Block Diagram**

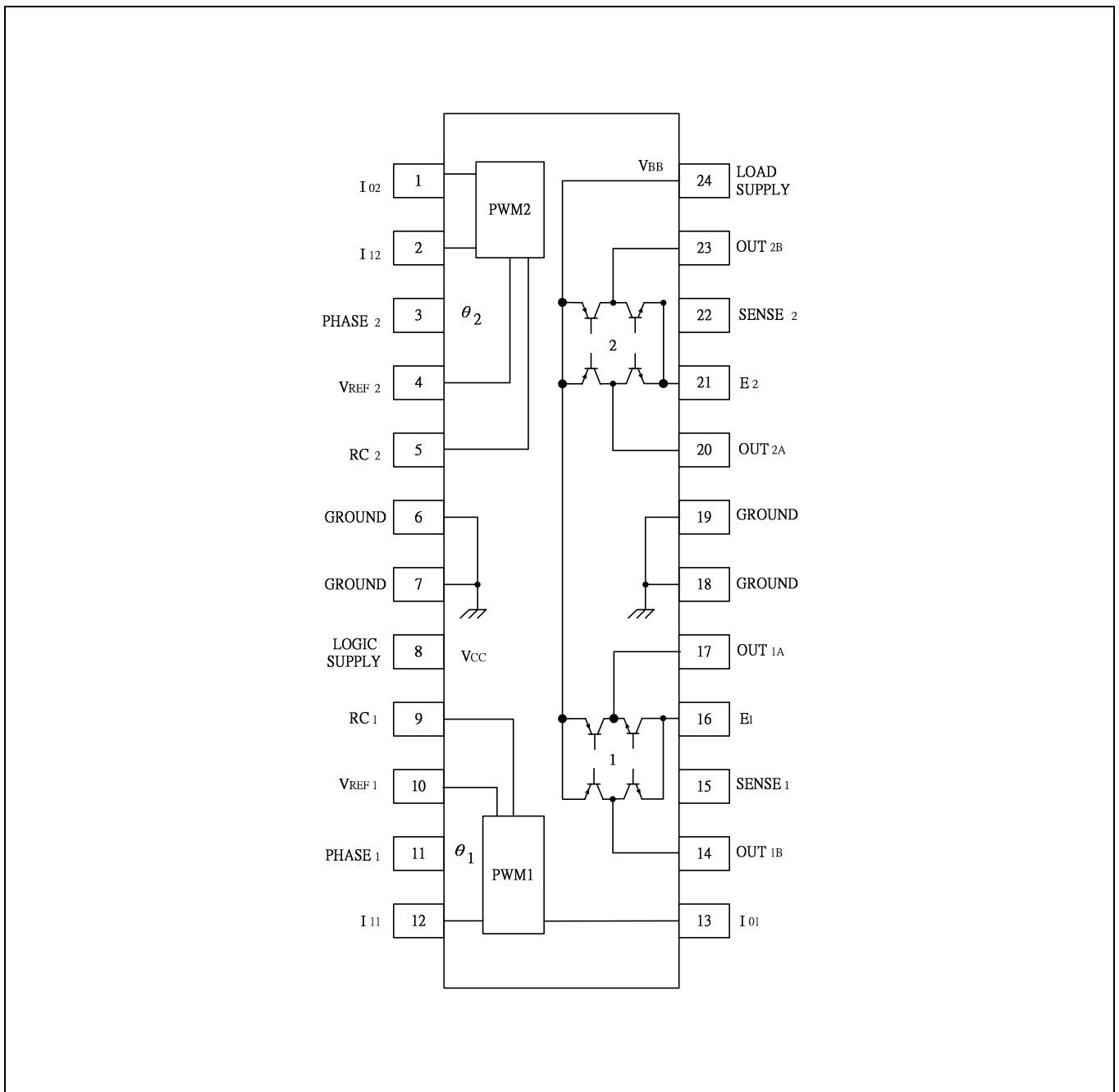

● PWM Current-Control Circuitry

Channel 1 terminal numbers shown

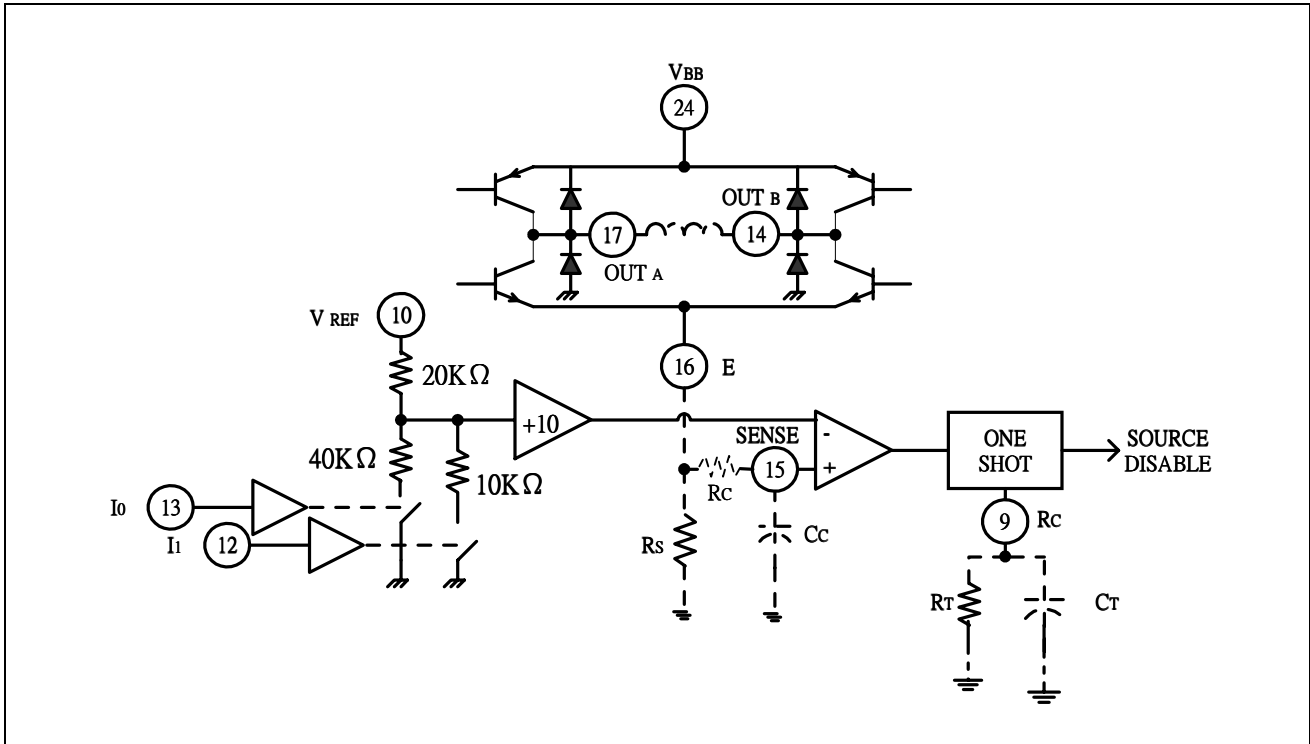

TRUTH TABLE

PHASE	OUT _A	OUT _B
H	H	L
L	L	H

- **Electrical Characteristics (Unless otherwise specified, $T_a = 25^\circ\text{C}$, $T_j \leq 150^\circ\text{C}$, $V_{BB} = 40\text{V}$, $V_{CC} = 4.75\text{V}$ to 5.25V , $V_{REF} = 5.0\text{V}$)**

Parameter	Symbol	Conditions	Limit			Unit
			Min	Typ	Max	
< Output Drivers (OUT_A or OUT_B) >						
Motor supply range	V_{BB}		10	-	40	V
Output leakage current	I_{CEX}	$V_{OUT} = V_{BB}$	-	< 1.0	50	μA
		$V_{OUT} = 0$	-	< -1.0	-50	μA
Output sustaining voltage	$V_{CE(sus)}$	$I_{OUT} = \pm 750\text{mA}$, $L = 3.0\text{mH}$	45	-	-	V
Output saturation voltage	$V_{CE(SAT)}$	Sink driver, $I_{OUT} = +500\text{mA}$	-	0.4	0.6	V
		Sink driver, $I_{OUT} = +750\text{mA}$	-	1.0	1.2	V
		Source driver, $I_{OUT} = -500\text{mA}$	-	1.0	1.2	V
		Source driver, $I_{OUT} = -750\text{mA}$	-	1.3	1.5	V
Clamp diode leakage current	I_R	$V_R = 45\text{V}$	-	< 1.0	50	μA
Clamp diode forward voltage	V_F	$I_F = 750\text{mA}$	-	1.6	2.0	V
Driver supply current	$I_{BB(ON)}$	Both bridges ON, no load	-	20	25	mA
	$I_{BB(OFF)}$	Both bridges OFF	-	5.0	10	mA
< Control Logic >						
Input voltage	$V_{IN(1)}$	All inputs	2.4	-	-	V
	$V_{IN(0)}$	All inputs	-	-	0.8	V
Input current	$I_{IN(1)}$	$V_{IN} = 2.4\text{V}$	-	< 1.0	20	μA
		$V_{IN} = 0.8\text{V}$	-	-3.0	-200	μA
Reference voltage range	V_{REF}	Operating	1.5	-	7.5	V
Current limit threshold (at trip point)	V_{REF}/V_{SENSE}	$I_0 = I_1 = 0.8\text{V}$	9.5	10	10.5	-
		$I_0 = 2.4\text{V}$, $I_1 = 0.8\text{V}$	13.5	15	16.5	-
		$I_0 = 0.8\text{V}$, $I_1 = 2.4\text{V}$	25.5	30	34.5	-
Thermal shutdown temperature	T_J		-	170	-	$^\circ\text{C}$
Total logic supply current	$I_{CC(ON)}$	$I_0 = I_1 = 0.8\text{V}$, No load	-	40	50	mA
	$I_{CC(OFF)}$	$I_0 = I_1 = 2.4\text{V}$, No load	-	10	12	mA

● Application Information

•PWM Current control

The AM2916 dual bridge is designed to drive both windings of a bipolar stepper motor or to control bidirectionally two DC motors. The output current of each part is sensed and controlled independently in each bridge by external sense resistors (R_S), internal comparator, and monostable multivibrator.

When the bridge is turned ON, current increases in the motor winding and it is sensed by the external sense resistor until the sense voltage (V_{SENSE}) reaches the level set at the comparator's input:

$$I_{TRIP} = V_{REF} / 10R_S$$

The comparator then triggers the monostable that turns OFF the source driver of the bridge. The actual load current peak will be slightly higher than the trip point (especially for low-inductance loads) because of the internal logic and switching delays. This delay (t_d) is typically 2 μ s. After turn-off, the motor current decays, circulating through the ground-clamp diode and sink transistor. The source driver's OFF time (and therefore the magnitude of the current decrease) is determined by the monostable's external RC timing components, where $t_{off} = R_T C_T$ within the range of 20k Ω to 100k Ω and 100pF to 1000pF.

When the source driver is re-enabled, the winding current (the sense voltage) is again allowed to rise to the comparator's threshold. This cycle repeats itself, maintaining the average motor winding current at the desired level. Loads with highly distributed capacitances may result in high turn-ON current peaks. This peak (appearing across R_S) will attempt to trip the comparator, resulting in erroneous current control or high-frequency oscillations. An external $R_C C_C$ time delay should be used to further delay the action of the comparator. Depending on load type, many applications will not require these external components (SENSE connected to E).

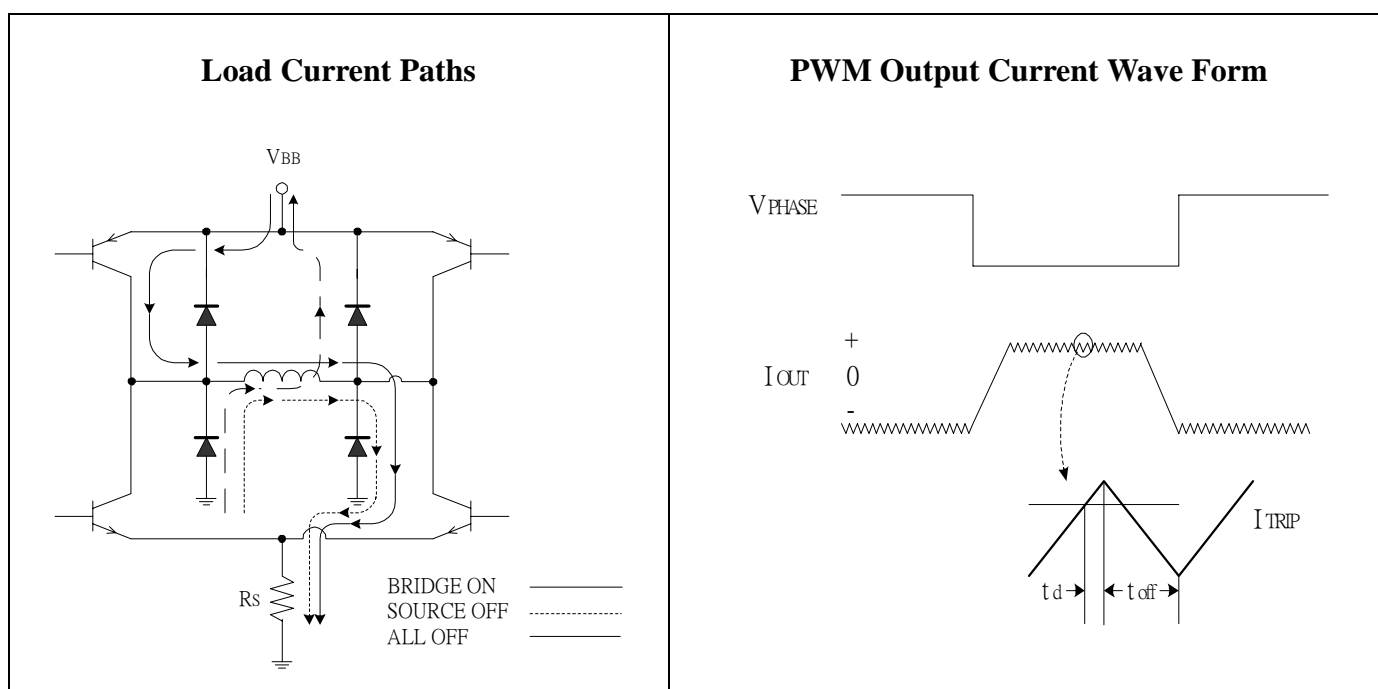

•Logic Control Of Output Current

Two logic level inputs (I_0 and I_1) allow digital selection of the motor winding current at 100%, 67%, 33%, or 0% of the maximum level (see table). The 0% output current condition turns OFF all drivers in the bridge and can be used as an OUTPUT DISABLE function.

Current – Control Truth Table

I_0	I_1	Output Current
L	L	$V_{REF} / 10R_S = I_{TRIP}$
H	L	$V_{REF} / 15R_S = 2/3 I_{TRIP}$
L	H	$V_{REF} / 30R_S = 1/3 I_{TRIP}$
H	H	0

These logic level inputs greatly enhance the implementation of μ P-controlled drive formats.

During half-step operations, the I_0 and I_1 allow the μ P to control the motor at a constant torque between all positions in an eight-step sequence. This is accomplished by digitally selecting 100% drive current when only one phase is ON and 67% drive current when two phases are ON. Logic highs on both I_0 and I_1 turn OFF all drivers to allow rapid current decay when switching phases. This helps to ensure proper motor operation at high step rates.

The logic control inputs can also be used to select a reduced current level (and reduced power dissipation) for 'hold' conditions and/or increased current (and available torque) for start-up conditions.

•General

The PHASE input to each bridge determines the direction of current flow in the motor winding. An internally generated deadtime (approximately 2μ s) prevents crossover currents that can occur when switching the PHASE input. All four drivers in the bridge output can be turned OFF between steps ($I_0 = I_1 \geq 2.4V$) resulting in a fast current decay through the internal output clamp and flyback diodes. The fast current decay is desirable in half-step and high-speed applications. All inputs float high.

Varying the reference voltage (V_{REF}) provides continuous control of the peak load current for microstepping applications and DC motor control.

Thermal protection circuitry turns OFF all drivers when the junction temperature reaches $+170^\circ C$. It is only intended to protect the device from failures due to excessive junction temperature and should not imply that output short circuits are permitted. The output drivers are re-enabled when the junction temperature cools to $+145^\circ C$.

The AM2916 output drivers are optimized for low output saturation voltages – less than 1.8V total (source plus sink) at 500mA. Under normal operating conditions, when combined with the excellent thermal properties of the batwing packing design, this allows continuous operation of both bridges simultaneously at 500mA.

● Typical Application

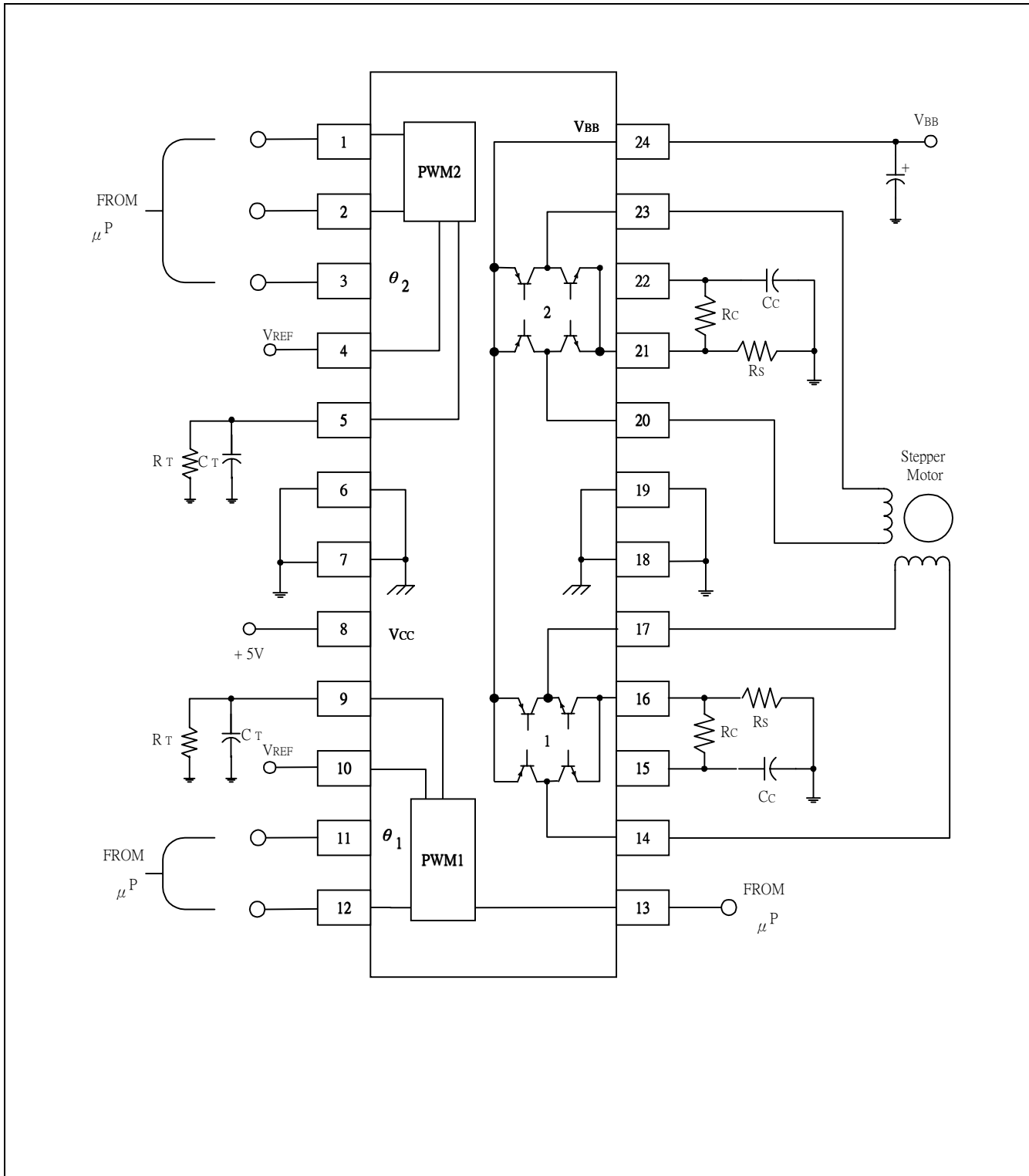

● Package Outline

SOP24

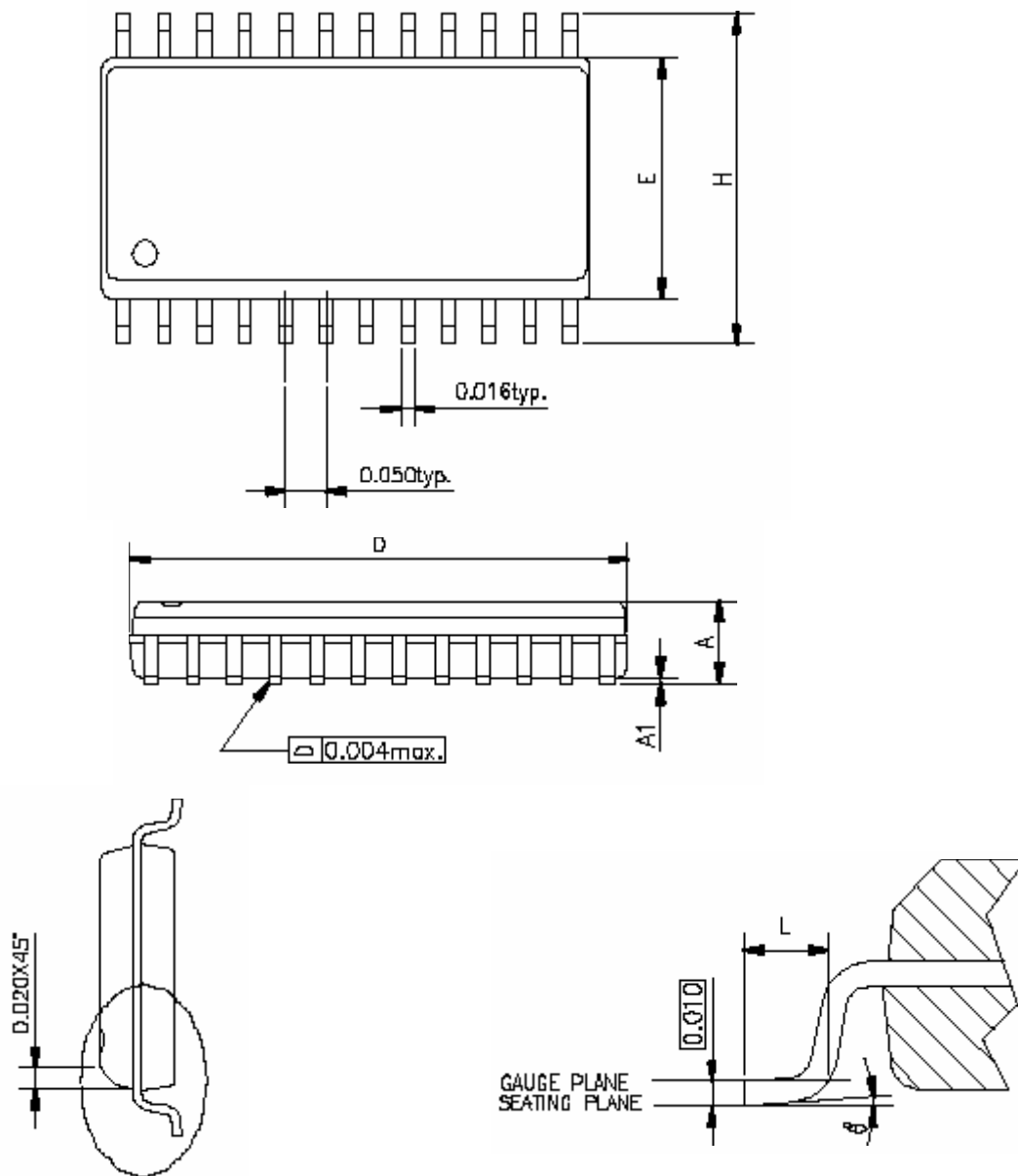

SYMBOL	MILLIMETERS		INCHES	
	Min.	Max.	Min.	Max.
A	2.36	2.64	0.093	0.104
A1	0.10	0.30	0.004	0.012
D	15.21	15.60	0.599	0.614
E	7.39	7.59	0.291	0.299
H	10.01	10.64	0.394	0.419
L	0.41	1.27	0.016	0.050
θ°	0°	8°	0°	8°