

**5-CHANNEL MOTOR DRIVER FOR DVD PLAYER****AM5665****General Description**

The AM5665 is a 5-channel BTL driver IC, in which two channels drive DC motor, two channels with current feedback drive the coils, such as the focus and the tracking actuator of DVD player, and the other one channel drives the bi-direction DC motor for tray.

The AM5665 is available in standard HSOP-28 package.

Features

- 2-channel DC Motor BTL Driver
- 2-channel BTL Driver for Coils with Current Feedback
- 1-channel Forward/Reverse Control DC Motor Driver
- Built-in Thermal Shutdown Circuit
- Built-in Standby Circuit
- Operating Voltage: 4.5 to 8.0V

Applications

- DVD Player



Figure 1. Package Type of AM5665



5-CHANNEL MOTOR DRIVER FOR DVD PLAYER

AM5665

Pin Configuration

M Package
(HSOP-28)

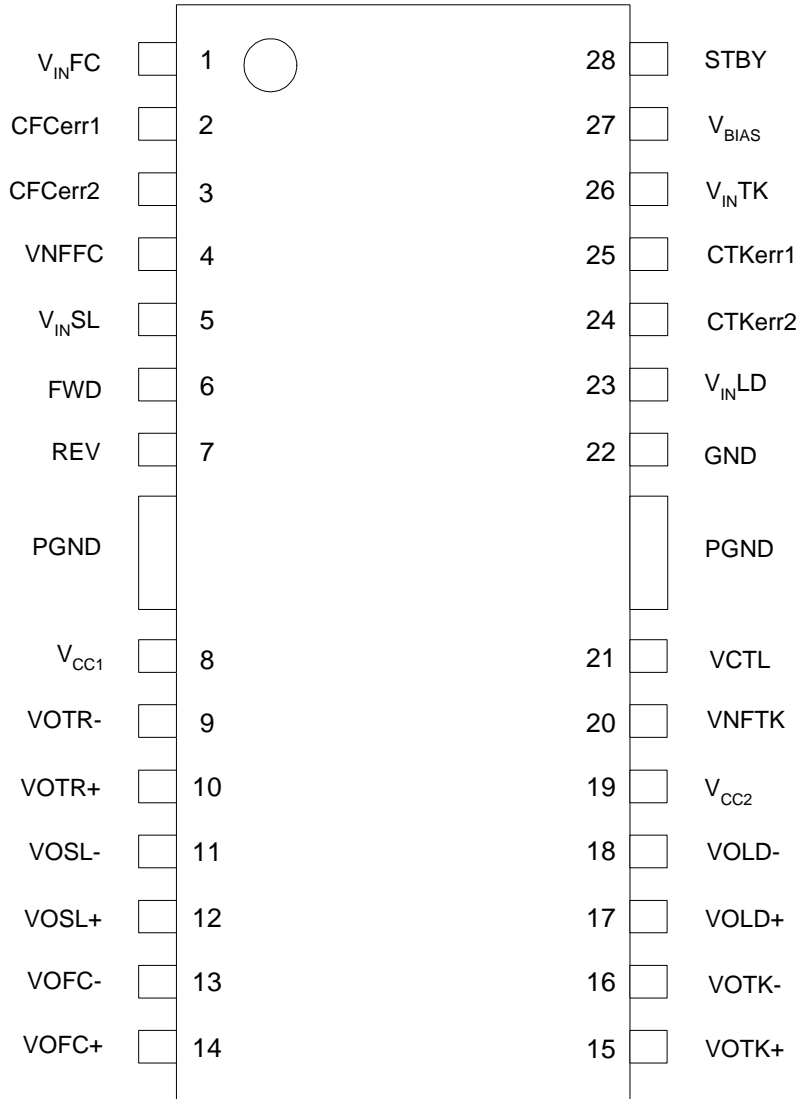

Figure 2. Pin Configuration of AM5665 (Top View)

**5-CHANNEL MOTOR DRIVER FOR DVD PLAYER****AM5665****Pin Description**

Pin Number	Pin Name	Function
1	V _{INFC}	Focus driver input
2	CFCerr1	Capacitor connection 1 for the error amp filter of focus channel
3	CFCerr2	Capacitor connection 2 for the error amp filter of focus channel
4	VNFFC	Focus driver feedback pin
5	V _{INSL}	Sled driver input
6	FWD	Tray driver forward input
7	REV	Tray driver reverse input
8	V _{CC1}	Power supply 1
9	VOTR-	Tray driver output (-)
10	VOTR+	Tray driver output (+)
11	VOSL-	Sled driver output (-)
12	VOSL+	Sled driver output (+)
13	VOFC-	Focus driver output (-)
14	VOFC+	Focus driver output (+)
15	VOTK+	Tracking driver output (+)
16	VOTK-	Tracking driver output (-)
17	VOLD+	Loading driver output (+)
18	VOLD-	Loading driver output (-)
19	V _{CC2}	Power supply 2
20	VNFTK	Tracking driver feedback pin
21	VCTL	Tray driver speed control pin
22	GND	Ground
23	V _{INLD}	Loading driver input
24	CTKerr2	Capacitor connection 2 for the error amp filter of tracking channel
25	CTKerr1	Capacitor connection 1 for the error amp filter of tracking channel
26	V _{INTK}	Tracking driver input
27	V _{BIAS}	VREF input pin
28	STBY	Stand-by control



5-CHANNEL MOTOR DRIVER FOR DVD PLAYER

AM5665

Functional Block Diagram

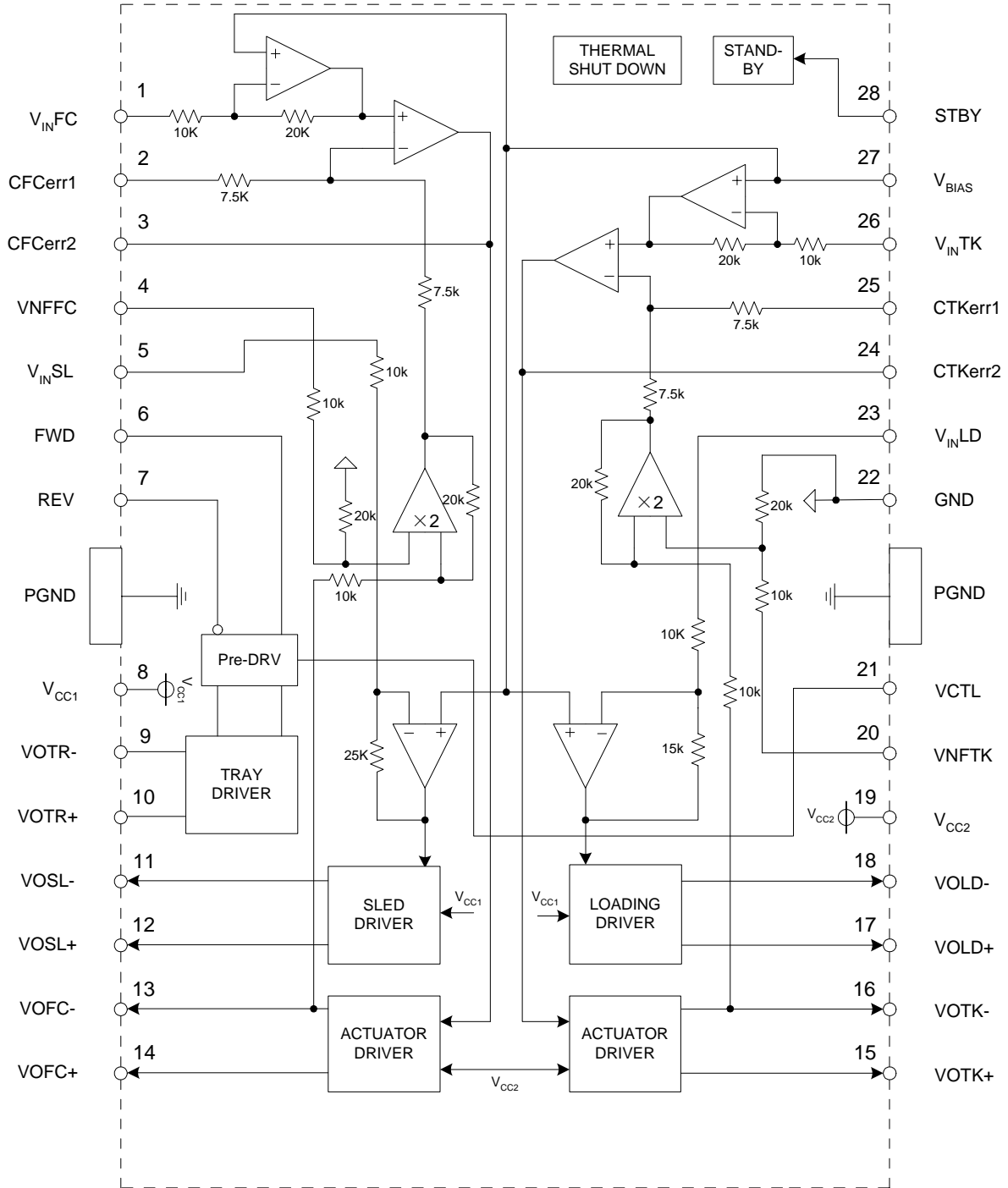
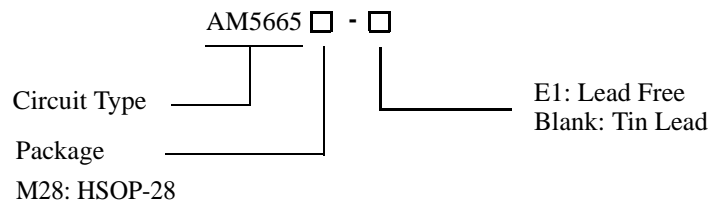

Figure 3. Functional Block Diagram of AM5665

**5-CHANNEL MOTOR DRIVER FOR DVD PLAYER****AM5665****Ordering Information**

Package	Temperature Range	Part Number		Marking ID		Packing Type
		Tin Lead	Lead Free	Tin Lead	Lead Free	
HSOP-28	0 to 70°C	AM5665M28	AM5665M28-E1	AM5665M28	AM5665M28-E1	Tube

BCD Semiconductor's Pb-free products, as designated with "E1" suffix in the part number, are RoHS compliant.

Absolute Maximum Ratings (Note 1)

Parameter	Symbol	Value	Unit
Supply Voltage	$V_{CC1,2}$	9.6	V
ESD (HBM)	ESD	2000	V
Power Dissipation	P_D	1.7	W
Storage Temperature Range	T_{STG}	-55 to 150	°C

Note 1: Stresses greater than those listed under "Absolute Maximum Ratings" may cause permanent damage to the device. These are stress ratings only, and functional operation of the device at these or any other conditions beyond those indicated under "Recommended Operating Conditions" is not implied. Exposure to "Absolute Maximum Ratings" for extended periods may affect device reliability.

Recommended Operating Conditions

Parameter	Symbol	Min	Max	Unit
Supply Voltage	V_{CC1}	4.5	8.0	V
	V_{CC2}	4.5 to V_{CC1}		V
Operating Temperature	T_A	0	70	°C



5-CHANNEL MOTOR DRIVER FOR DVD PLAYER

AM5665

Electrical Characteristics

($T_A=25^\circ\text{C}$, $V_{CC1}=V_{CC2}=5\text{V}$, $V_{BIAS}=1.65\text{V}$, $R_{L1}=R_{L2}=8\Omega$, $R_{L3}=R_{L4}=12\Omega$, $R_{L5}=45\Omega$, unless otherwise specified.)

Parameter	Symbol	Conditions	Min	Typ	Max	Unit
Quiescent Current	I_{CC}	No load		18	27	mA
Standby Current	I_{ST}			2.3	4.0	mA
Standby on Voltage	V_{STON}		0		0.5	V
Standby off Voltage	V_{STOFF}		2.0		5.0	V
Actuator Driver						
Output Offset Current	$I_{OO1,2}$		-10		10	mA
Maximum Output Voltage	$V_{O1,2MAX}$	$V_{IN}=V_{BIAS}\pm 1.5\text{V}$	3.3	3.5		V
Transmission Gain	gm	$V_{IN}=V_{BIAS}\pm 0.2\text{V}$	1.3	1.5	1.7	A/V
Sled Motor Driver						
Output Offset Voltage	V_{OOSL}		-100		100	mV
Maximum Output Voltage	V_{O3MAX}	$V_{IN}=V_{BIAS}\pm 1.5\text{V}$	3.3	3.5		V
Closed-loop Voltage Gain	G_{VSL}	$V_{IN}=V_{BIAS}\pm 0.2\text{V}$	18.0	20.0	22.0	dB
Loading Motor Driver						
Output Offset Voltage	V_{OOLD}		-50		50	mV
Maximum Output Voltage	V_{O4MAX}	$V_{IN}=V_{BIAS}\pm 5.5\text{V}$	3.3	3.5		V
Closed-Loop Voltage Gain	G_{VLD}	$V_{IN}=V_{BIAS}\pm 0.2\text{V}$	14	16	18	dB
Gain Error by Polarity	ΔG_{VLD}		0	1	2	dB
Tray Motor Driver						
Output Offset Voltage	V_{OOTR}	$R_{L5}=45\Omega$, $R_{VCTL}=0\Omega$	-50	0	50	mV
Maximum Output Voltage	V_{O5MAX1}	$R_{L5}=45\Omega$, $R_{VCTL}=400\Omega$	1.3	1.5	1.7	V
	V_{O5MAX2}	$R_{L5}=45\Omega$, $R_{VCTL}=0\Omega$	3.8	4.0	4.2	V
Input High Level Voltage	V_{IH}		2.0		5.0	V
Input Low Level Voltage	V_{IL}		0		0.8	V



5-CHANNEL MOTOR DRIVER FOR DVD PLAYER

AM5665

Test Circuit

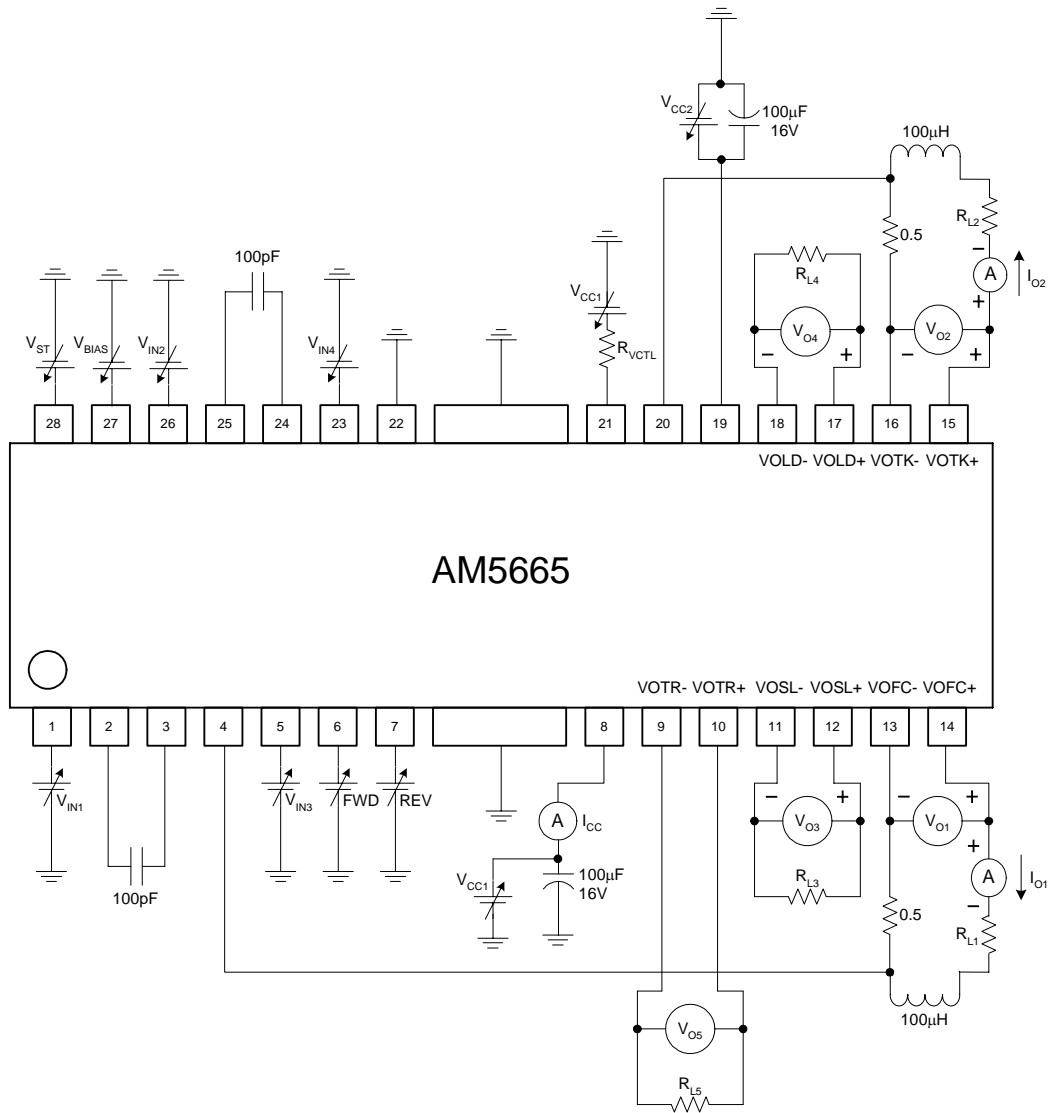

Figure 4. Test Circuit of AM5665



5-CHANNEL MOTOR DRIVER FOR DVD PLAYER

AM5665

Typical Performance Characteristics (Note 2)

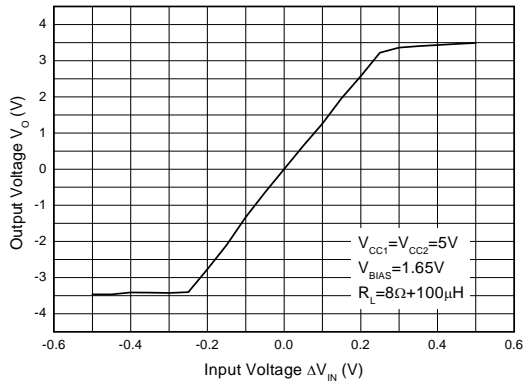

Figure 5. Driver I/O Characteristics (Focus)

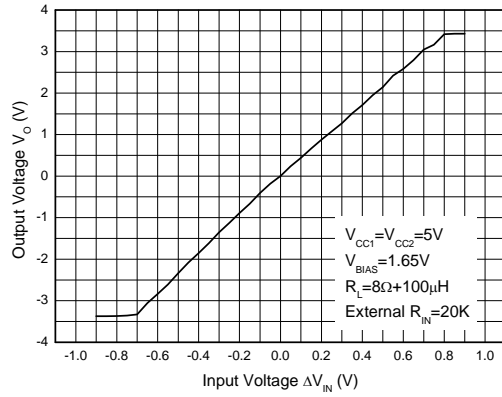

Figure 6. Driver I/O Characteristics (Focus)

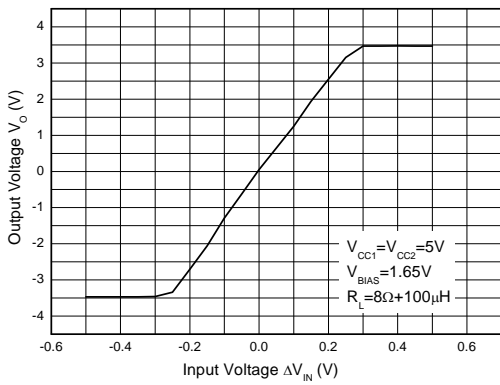

Figure 7. Driver I/O Characteristics (Track)

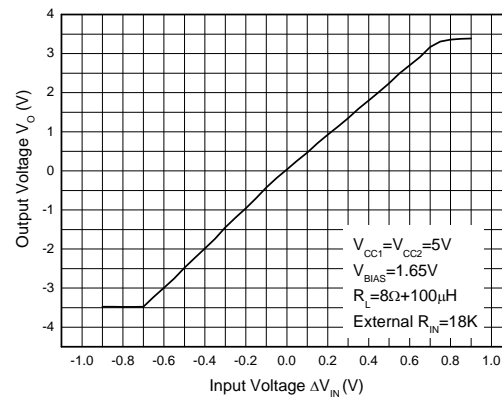

Figure 8. Driver I/O Characteristics (Track)



5-CHANNEL MOTOR DRIVER FOR DVD PLAYER

AM5665

Typical Performance Characteristics (Continued)

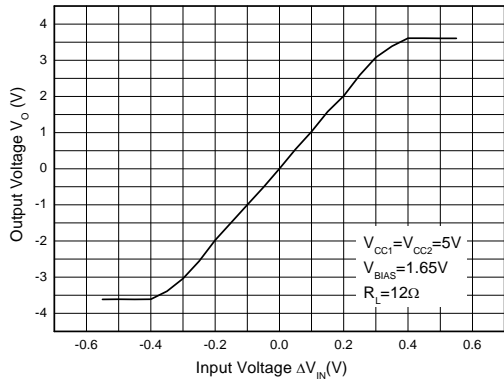

Figure 9. Driver I/O Characteristics (Sled)

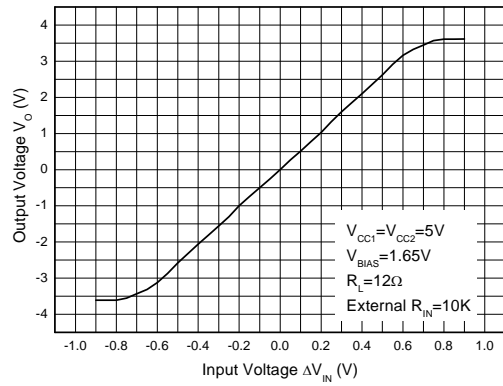

Figure 10. Driver I/O Characteristics (Sled)

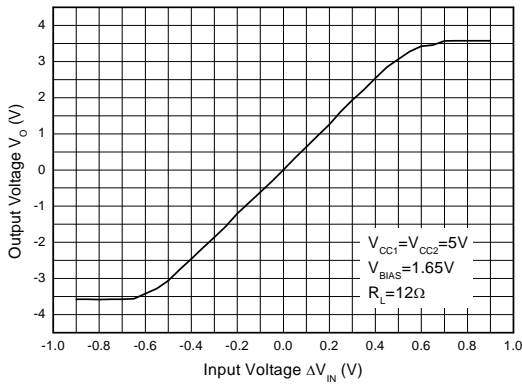

Figure 11. Driver I/O Characteristics (Loading)

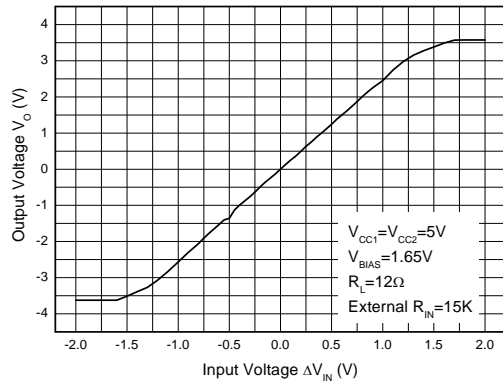

Figure 12. Driver I/O Characteristics (Loading)



5-CHANNEL MOTOR DRIVER FOR DVD PLAYER

AM5665

Typical Performance Characteristics (Continued)

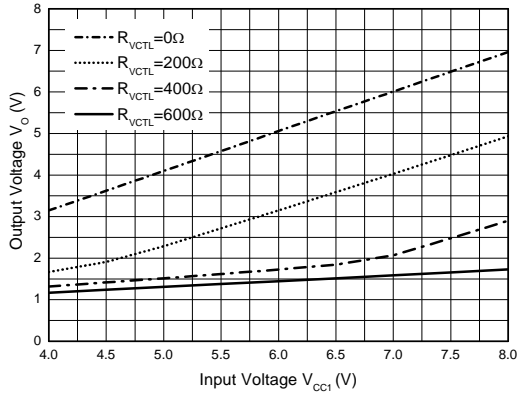

Figure 13. Tray Speed Control Characteristics

Note 2:

For the above figures 6, 8, 10, 12, please refer to the following "Typical Application" section.



5-CHANNEL MOTOR DRIVER FOR DVD PLAYER

AM5665

Typical Application

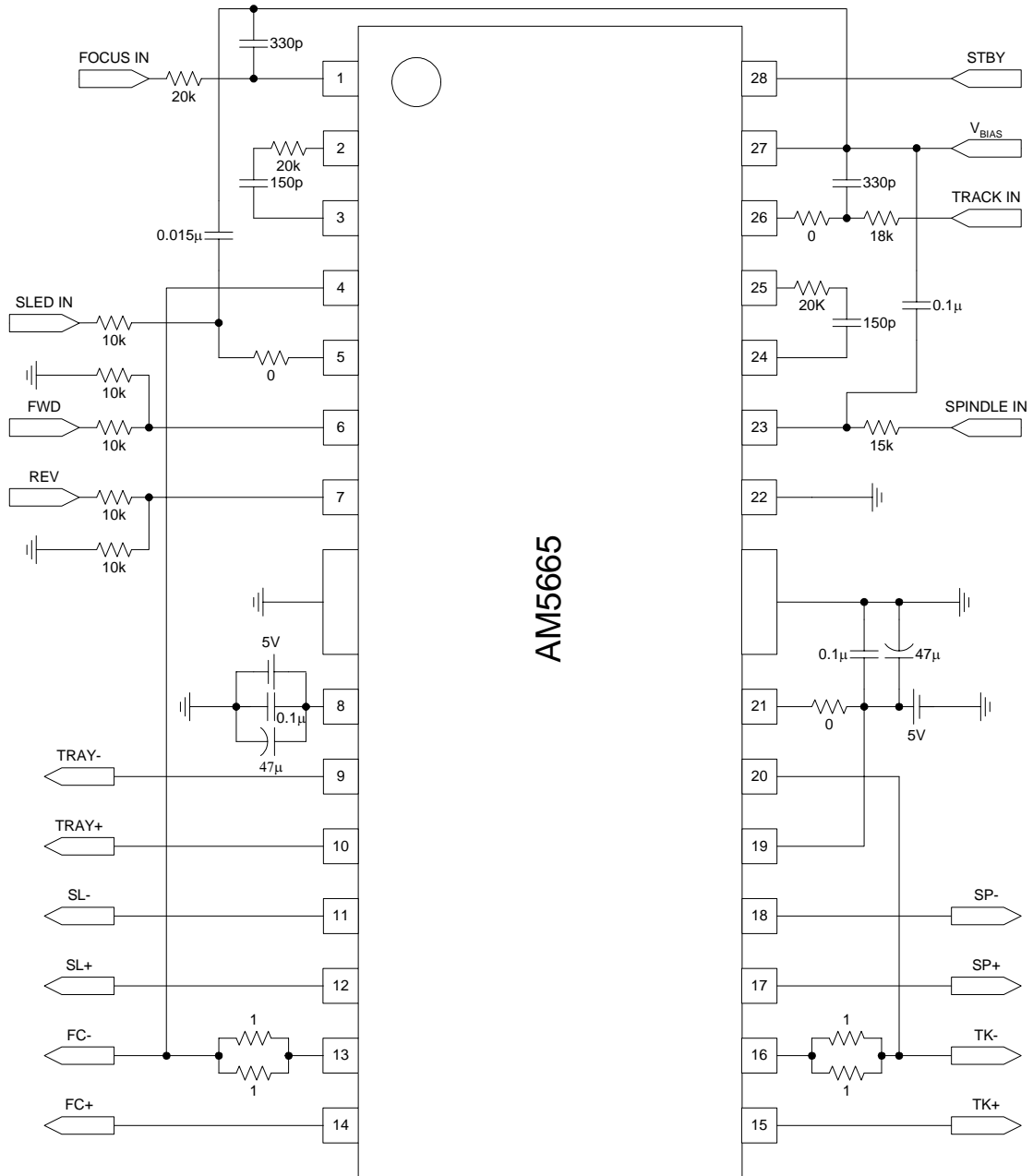

Figure 14. Typical Application of AM5665 in DVD Player



5-CHANNEL MOTOR DRIVER FOR DVD PLAYER

AM5665

Application Information

This application information is only for the Tray Motor Driver section.

Tray Motor Driver

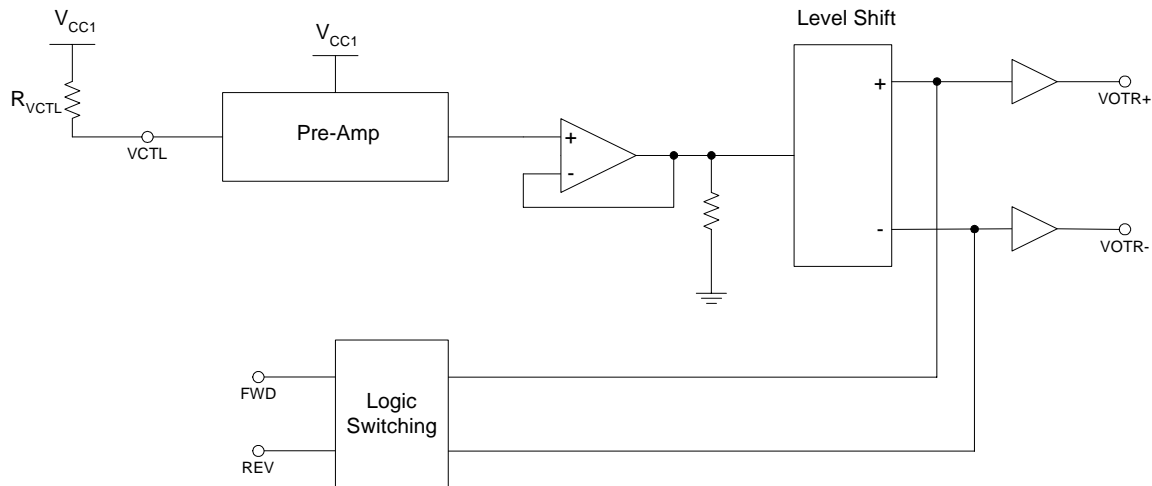

Figure 15. Tray Motor Driver Control Illustration

Output Status Control Table

Input		Output		
FWD	REV	VOTR+	VOTR-	Status
High	High	Low	Low	Break
High	Low	High	Low	Forward
Low	High	Low	High	Reverse
Low	Low	Open	Open	Standby

Tray Motor Speed Control

The amplitude of output voltage depends on VCTL (pin 21). Connect a resistor between VCTL (pin 21) and V_{CC1}, and you can obtain different output voltages for tray driver by changing the value of R_{VCTL}. (See Figure 4.)



BCD Semiconductor Manufacturing Limited

<http://www.bcdsemi.com>

IMPORTANT NOTICE

BCD Semiconductor Manufacturing Limited reserves the right to make changes without further notice to any products or specifications herein. BCD Semiconductor Manufacturing Limited does not assume any responsibility for use of any its products for any particular purpose, nor does BCD Semiconductor Manufacturing Limited assume any liability arising out of the application or use of any its products or circuits. BCD Semiconductor Manufacturing Limited does not convey any license under its patent rights or other rights nor the rights of others.

MAIN SITE

BCD Semiconductor Manufacturing Limited
- Wafer Fab
Shanghai SIM-BCD Semiconductor Manufacturing Limited
800, Yi Shan Road, Shanghai 200233, China
Tel: +86-21-6485 1491, Fax: +86-21-5450 0008

BCD Semiconductor Manufacturing Limited
- IC Design Group
Advanced Analog Circuits (Shanghai) Corporation
8F, Zone B, 900, Yi Shan Road, Shanghai 200233, China
Tel: +86-21-6495 9539, Fax: +86-21-6485 9673

REGIONAL SALES OFFICE

Shenzhen Office
Shanghai SIM-BCD Semiconductor Manufacturing Co., Ltd. Shenzhen Office
Advanced Analog Circuits (Shanghai) Corporation Shenzhen Office
27B, Tower C, 2070, Middle Shen Nan Road, Shenzhen 518031, China
Tel: +86-755-8368 3987, Fax: +86-755-8368 3166

Taiwan Office
BCD Semiconductor (Taiwan) Company Limited
4F, 298-1, Rui Guang Road, Nei-Hu District, Taipei,
Taiwan
Tel: +886-2-2656 2808, Fax: +886-2-2656 2806

USA Office
BCD Semiconductor Corporation
3170 De La Cruz Blvd., Suite 105, Santa Clara,
CA 95054-2411, U.S.A
Tel: +1-408-988 6388, Fax: +1-408-988 6386