

**5-CHANNEL BTL DRIVER FOR DVD PLAYER****AM5669****General Description**

The AM5669 is a five-channel BTL driver IC, in which four channels are voltage type BTL drivers for tracking and focus actuators, sled and spindle motors, the other one channel is DC motor driver for tray which supports forward/reverse control. This IC also contains two independent precise voltage regulators with adjustable range from 1.5V to 4V and a free comparator for spindle channel motor direction detection.

The AM5669 is available in standard HSOP-28 package.

Features

- 4-channel DC Motor BTL Driver
- 1-channel Forward/Reverse Control DC Motor BTL Driver
- Two Built-in Regulator Controllers
- One Built-in Comparator for Spindle Channel Motor Direction Detection
- Built-in Level Shift Circuit
- Built-in Mute Mode
- Built-in Thermal Shutdown Circuit
- Operating Voltage: 4.3V to 8V

Applications

- DVD Player
- CD-ROM



Figure 1. Package Type of AM5669



5-CHANNEL BTL DRIVER FOR DVD PLAYER

AM5669

Pin Configuration

M28 Package
(HSOP-28)

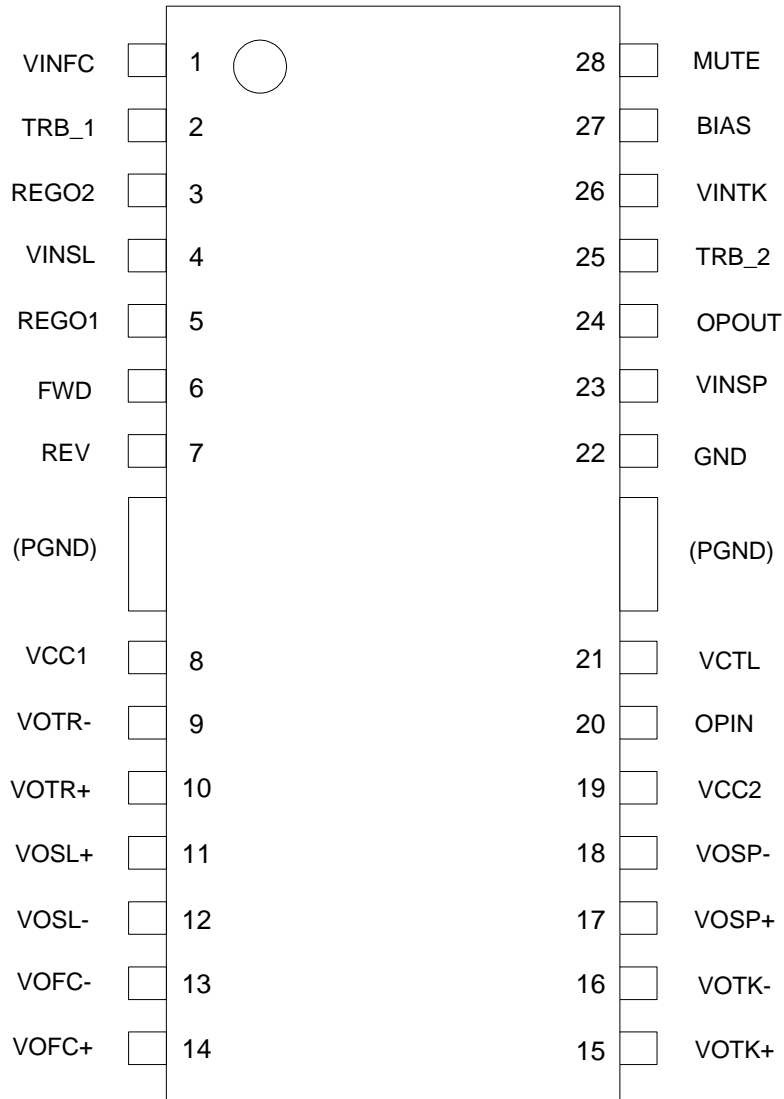

Figure 2. Pin Configuration of AM5669 (Top View)

**5-CHANNEL BTL DRIVER FOR DVD PLAYER****AM5669****Pin Description (Note 1)**

Pin Number	Pin Name	Function
1	VINFC	Input for focus driver
2	TRB_1	Regulator 1 driver output
3	REGO2	Regulator 2 feedback input
4	VINSL	Input for the sled driver
5	REGO1	Regulator 1 feedback input
6	FWD	Tray driver forward input
7	REV	Tray driver reverse input
8	VCC1	V _{CC} for pre-drive block and power block of sled and tray
9	VOTR-	Tray driver output (-)
10	VOTR+	Tray driver output (+)
11	VOSL+	Sled driver output (+)
12	VOSL-	Sled driver output (-)
13	VOFC-	Focus driver output (-)
14	VOFC+	Focus driver output (+)
15	VOTK+	Tracking driver output (+)
16	VOTK-	Tracking driver output (-)
17	VOSP+	Spindle driver output (+)
18	VOSP-	Spindle driver output (-)
19	VCC2	V _{CC} for power block of spindle, tracking and focus
20	OPIN	Comparator input (+)
21	VCTL	Speed control input of tray driver
22	GND	Ground
23	VINSP	Input for spindle driver
24	OPOUT	Comparator output
25	TRB_2	Regulator 2 driver output
26	VINTK	Input for tracking driver
27	BIAS	Input for reference voltage
28	MUTE	Input for mute control

Note 1: Symbols of + and - (output of drivers) mean polarity with respect to input pin.
(For example, if voltage of pin 1 is high, pin 14 is high and pin 13 is low.)



5-CHANNEL BTL DRIVER FOR DVD PLAYER

AM5669

Functional Block Diagram

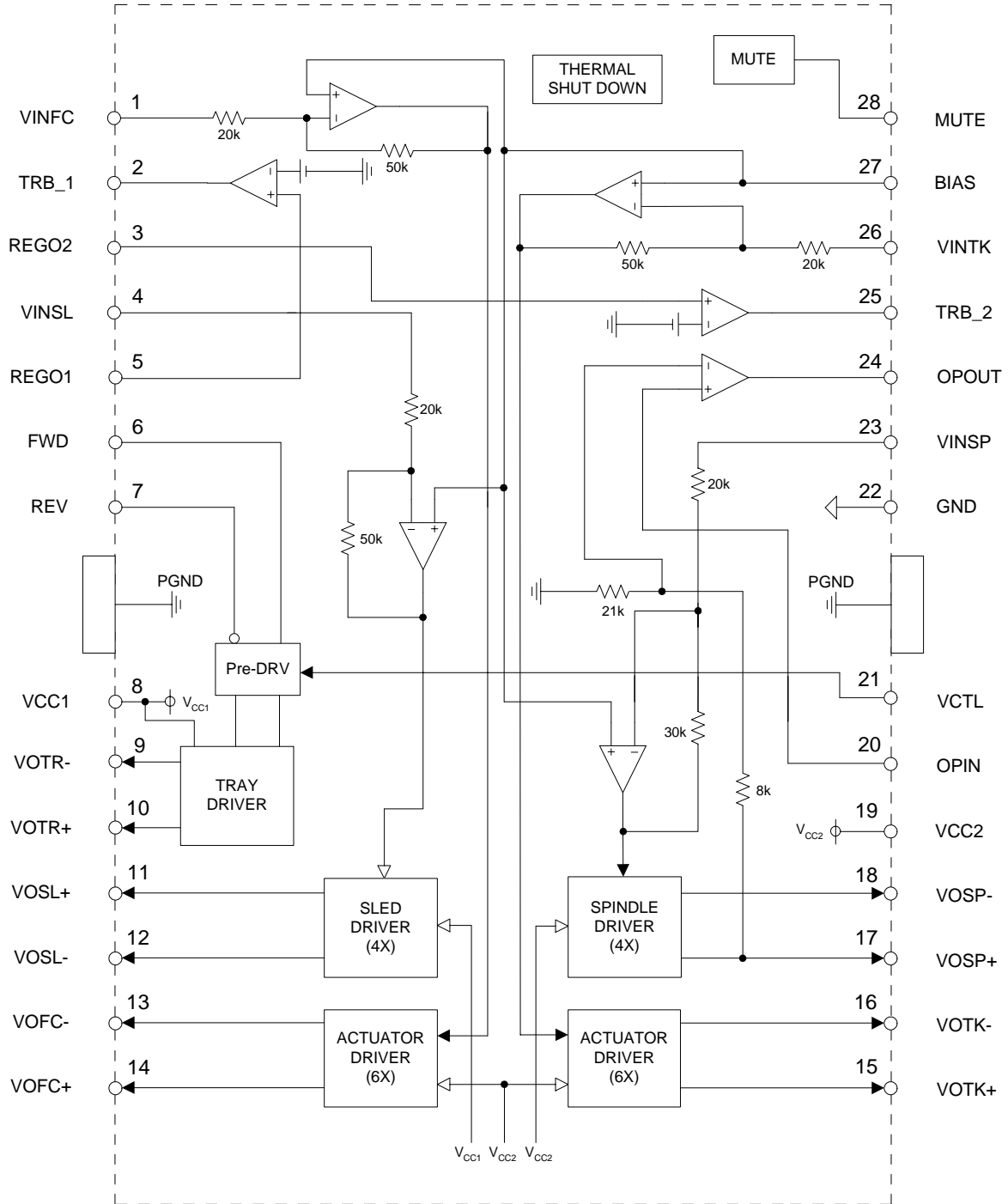
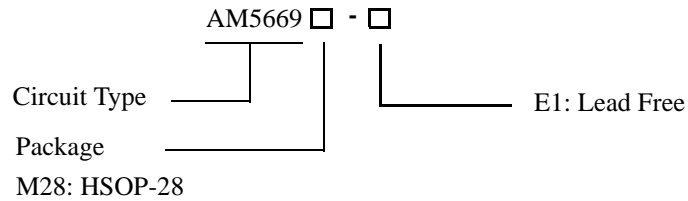

Figure 3. Functional Block Diagram of AM5669

**5-CHANNEL BTL DRIVER FOR DVD PLAYER****AM5669****Ordering Information**

Package	Temperature Range	Part Number		Marking ID		Packing Type
		Tin Lead	Lead Free	Tin Lead	Lead Free	
HSOP-28	0 to 70°C		AM5669M28-E1		AM5669M28-E1	Tube

BCD Semiconductor's Pb-free products, as designated with "E1" suffix in the part number, are RoHS compliant.

Absolute Maximum Ratings (T_A=25°C) (Note 2)

Parameter	Symbol	Value	Unit
Supply Voltage	V _{CC1, 2}	8.8	V
Power Dissipation	P _D	1.7 (Note 3)	W
Storage Temperature Range	T _{STG}	-55 to 150	°C
ESD (Human Body Model)	ESD	2000	V
ESD (Machine Model)	ESD	200	V

Note 2: Stresses greater than those listed under "Absolute Maximum Ratings" may cause permanent damage to the device. These are stress ratings only, and functional operation of the device at these or any other conditions beyond those indicated under "Recommended Operating Conditions" is not implied. Exposure to "Absolute Maximum Ratings" for extended periods may affect device reliability.

Note 3:

- When mounted on a 70mm×70mm×1.6mm glass epoxy board.
- Reduced by 13.6mW for each increase in T_A of 1°C over 25°C.

Recommended Operating Conditions (T_A=25°C)

Parameter	Symbol	Min	Max	Unit
Power Supply Voltage	V _{CC1}	4.3	8	V
	V _{CC2}	4.3 to V _{CC1}		V
Operating Temperature	T _A	0	70	°C



5-CHANNEL BTL DRIVER FOR DVD PLAYER

AM5669

Electrical Characteristics (Note 4)

($T_A=25^\circ\text{C}$, $V_{CC1}=V_{CC2}=5\text{V}$, $V_{BIAS}=1.65\text{V}$, $R_L=10\Omega/45\Omega$, unless otherwise specified.)

Parameter	Symbol	Conditions	Min	Typ	Max	Unit
Quiescent Current	I_{QC}			16		mA
Mute ON Voltage	V_{STON}		0		0.5	V
Mute OFF Voltage	V_{STOFF}		2.0		V_{CC1}	V
Focus Driver						
Output Offset Voltage	V_{OOFFC}		-50		50	mV
Maximum Output Voltage	V_{OMFC}	at 10Ω load	3.0	3.5		V
Closed-loop Voltage Gain	G_{VFC}	$V_{IN}=V_{BIAS} \pm 0.2\text{V}$	21.5	23.5	25.5	dB
Tracking Driver						
Output Offset Voltage	V_{OOFTK}		-50		50	mV
Maximum Output Voltage	V_{OMTK}	at 10Ω load	3.0	3.5		V
Closed-loop Voltage Gain	G_{VTK}	$V_{IN}=V_{BIAS} \pm 0.2\text{V}$	21.5	23.5	25.5	dB
Spindle Driver						
Output Offset Voltage	V_{OOFSPL}		-50		50	mV
Maximum Output Voltage	V_{OMSP}	at 10Ω load	3.0	3.5		V
Closed-loop Voltage Gain	G_{VSP}	$V_{IN}=V_{BIAS} \pm 0.2\text{V}$	13.5	15.5	17.5	dB
Gain Error by Polarity	ΔG_{VSP}	$V_{IN}=V_{BIAS} \pm 0.2\text{V}$	0	1	2	dB
Sled Driver						
Output Offset Voltage	V_{OOFSL}		-100		100	mV
Maximum Output Voltage	V_{OMSL}	at 10Ω load	3.0	3.5		V
Closed-loop Voltage Gain	G_{VSL}	$V_{IN}=V_{BIAS} \pm 0.2\text{V}$	18.0	20.0	22.0	dB
Tray Driver						
Output Saturation Voltage 1	V_{SAT1TR}	Upper + Lower saturation, $I_L=200\text{mA}$	0.7	1.3	1.6	V
Output Saturation Voltage between FWD and REV	ΔV_{SAT1TR}	Output Saturation Voltage 1 between FWD and REV	-0.1		0.1	V
Output Saturation Voltage 2	V_{SAT2TR}	Upper + Lower saturation, $I_L=500\text{mA}$	1.0	2.1	2.5	V
Output Adjustable Gain on "H" Side Voltage	G_{VTRH}	at 45Ω load, $V_{CTL}=1\text{V}$	7.4	9.2	11	dB

**5-CHANNEL BTL DRIVER FOR DVD PLAYER****AM5669****Electrical Characteristics (Continued, Note 4)**

Parameter	Symbol	Conditions	Min	Typ	Max	Unit
Tray Motor Driver Input Logic						
High Level Input Voltage	V_{IH}		1.5		V_{CC1}	V
Low Level Input Voltage	V_{IL}		-0.3		0.5	V
High Level Input Current	I_{IH}	$V_{FWD}=V_{REV}=5V$		110	270	μA
Regulator (Note 5)						
Output Voltage	V_{REG}	$I_L=500mA$	1.5		4.0	V
Output Load Differential	ΔV_{RL}	$I_L=0$ to 500mA	-50	0	50	mV
Power Supply Voltage Differential	ΔV_{VCC}	$V_{CC}=4.3$ to 8V, $I_L=500mA$	-25	0	25	mV

Note 4: This device is not designed for protection against radioactive rays.

Note 5: It is based on 8550D PNP application.



5-CHANNEL BTL DRIVER FOR DVD PLAYER

AM5669

Test Circuit

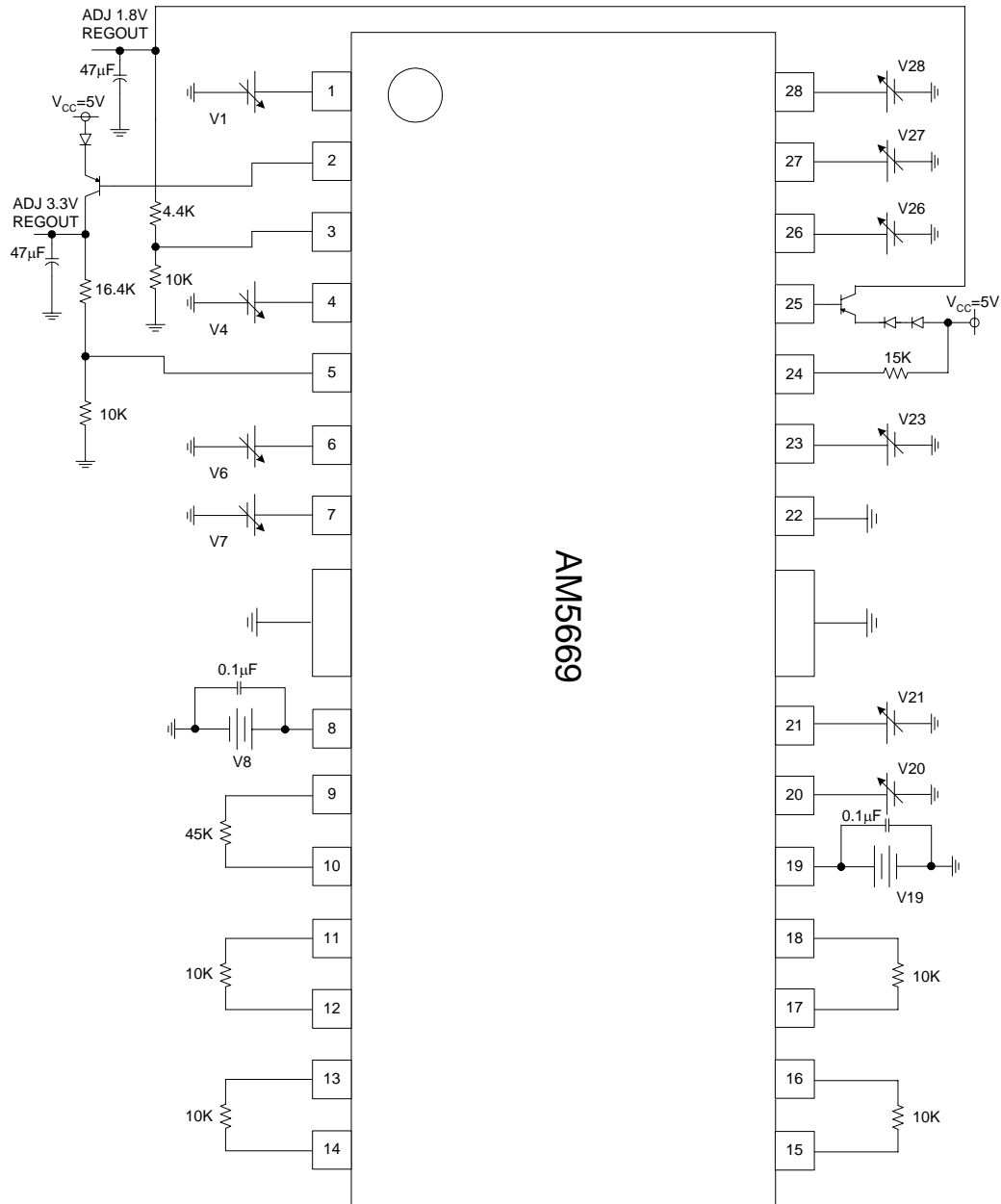

Figure 4. Test Circuit of AM5669



5-CHANNEL BTL DRIVER FOR DVD PLAYER

AM5669

Typical Performance Characteristics

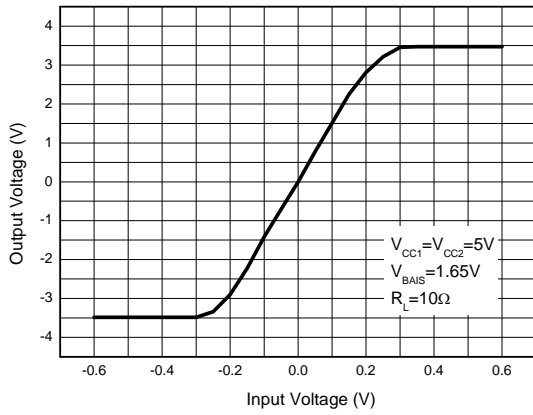

Figure 5. Focus Driver Characteristics

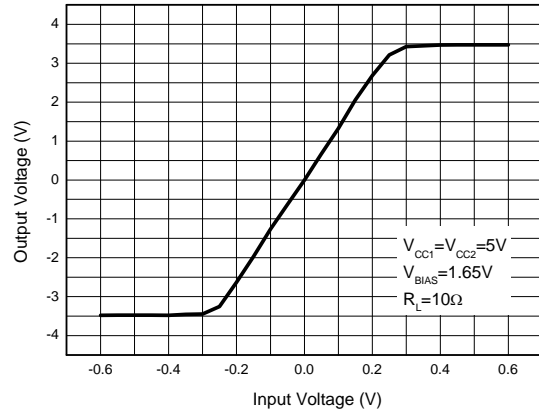

Figure 6. Tracking Driver Characteristics

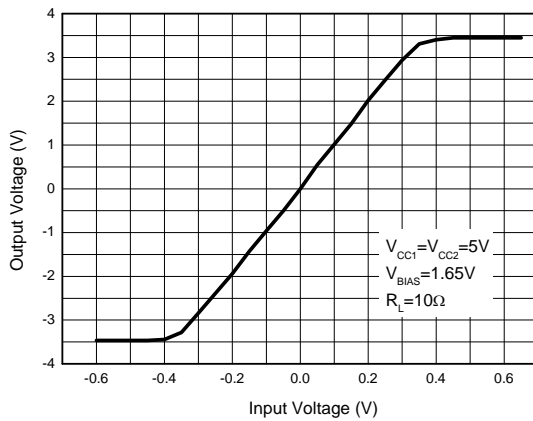

Figure 7. Sled Driver Characteristics

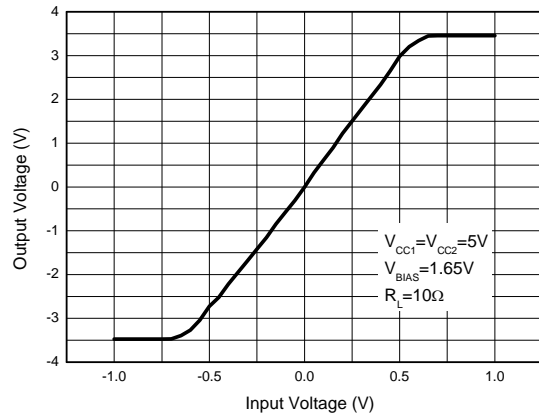

Figure 8. Spindle Driver Characteristics



5-CHANNEL BTL DRIVER FOR DVD PLAYER

AM5669

Typical Performance Characteristics (Continued)

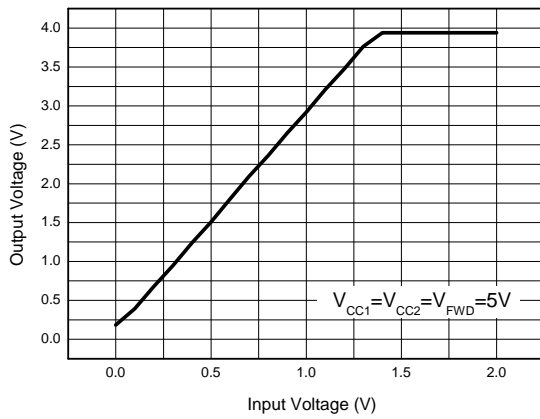

Figure 9. Tray Channel Output Amplitude vs. VCTL Voltage

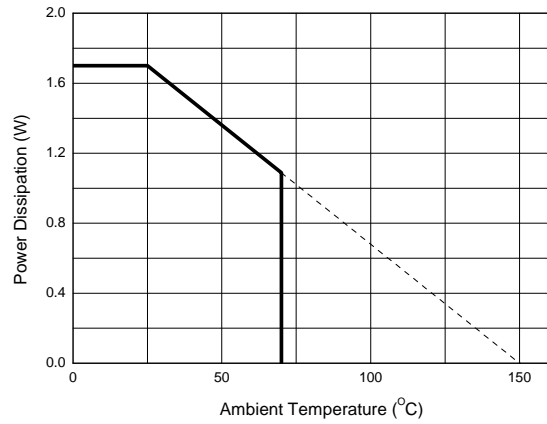

Figure 10. Power Dissipation Curve (Note 3)



5-CHANNEL BTL DRIVER FOR DVD PLAYER

AM5669

Typical Application

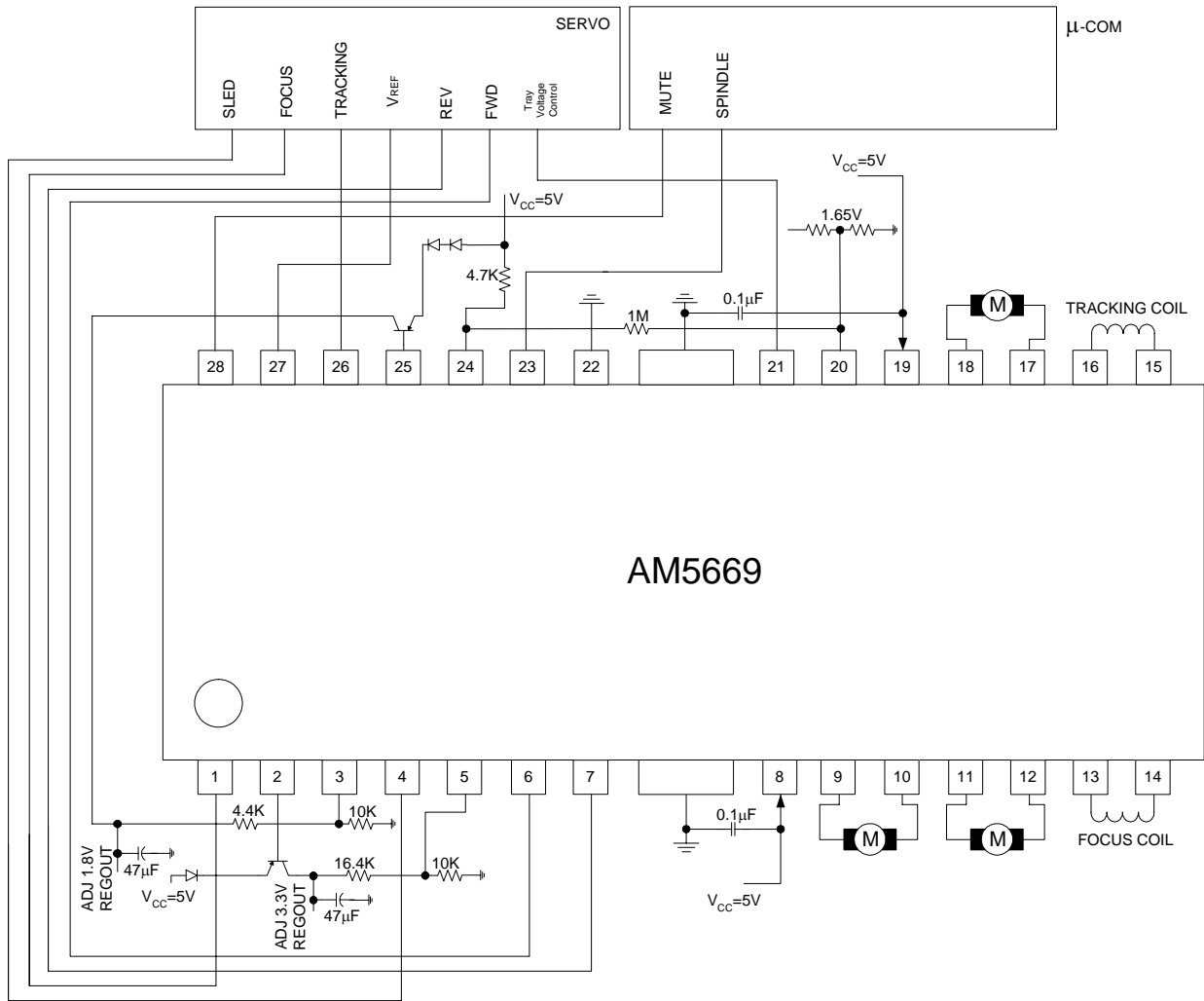

Figure 11. Typical Application of AM5669 in DVD Player

**5-CHANNEL BTL DRIVER FOR DVD PLAYER****AM5669****Application Information**

1. The built-in thermal shutdown circuit mutes the output current when the chip temperature reaches 175°C (Typ). The hysteresis is set to 30°C (Typ), so the circuit will start up again when the chip temperature falls to 145°C (Typ).

2. In case mute pin voltage is under 0.5V or this pin is not connected, output current is muted (except for tray motor driver). Mute pin voltage should be more than 2.0V for normal application.

3. Bias pin (pin 27) should be pulled up to more than 1.2V. In case the bias pin voltage is pulled down below 0.9V (Typ), the output current is muted.

4. Insert the bypass capacitor (about 0.1μF) between VCC1,2 pin and GND pin as close as possible to this chip.

5. Heat dissipation fins are attached to the GND on the inside of the package. Make sure to connect them to the external GND.

6. Tray driver logic input:

FWD (pin6)	REV (pin7)	VOTR+ (pin10)	VOTR- (pin9)	Function
L	L	OPEN	OPEN	Open mode
L	H	L	H	Reverse mode
H	L	H	L	Forward mode
H	H	L	L	Brake mode

Input circuit of pins 6 and 7 is designed to avoid simultaneous activation of upper and lower output tray; however, in order to improve reliability, apply motor forward/reverse input once through open mode. We recommend time period for open longer than 10msec.

"H" side output voltage on output pins (VOTR+ or VOTR-) varies depending on output control terminal for tray (pin 21). "H" side output voltage is set to three times (9.2dB Typ) the voltage of VCTL (pin 21). And, "L" side output voltage is equal to output saturation voltage.



5-CHANNEL BTL DRIVER FOR DVD PLAYER

AM5669

Mechanical Dimensions

HSOP-28

Unit: mm(inch)

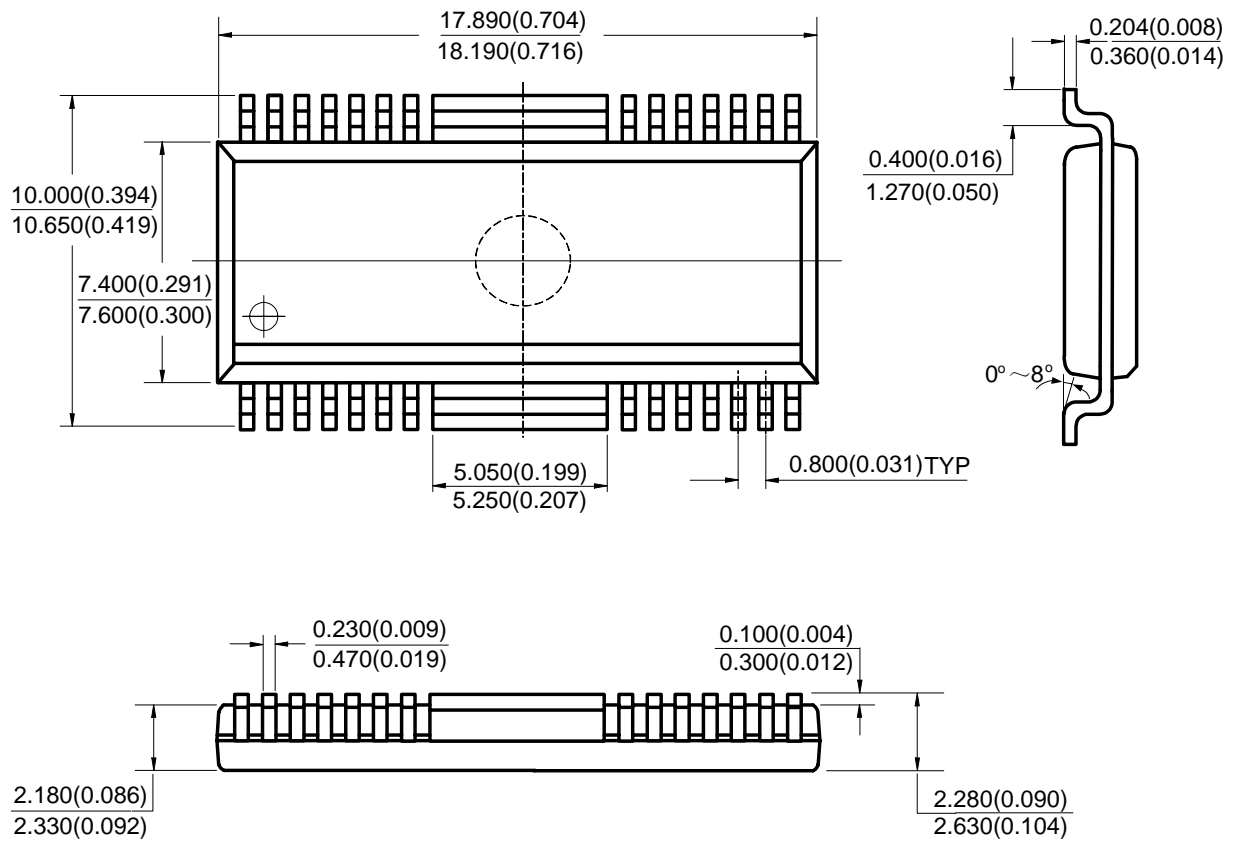



BCD Semiconductor Manufacturing Limited

<http://www.bcdsemi.com>

IMPORTANT NOTICE

BCD Semiconductor Manufacturing Limited reserves the right to make changes without further notice to any products or specifications herein. BCD Semiconductor Manufacturing Limited does not assume any responsibility for use of any its products for any particular purpose, nor does BCD Semiconductor Manufacturing Limited assume any liability arising out of the application or use of any its products or circuits. BCD Semiconductor Manufacturing Limited does not convey any license under its patent rights or other rights nor the rights of others.

MAIN SITE

BCD Semiconductor Manufacturing Limited
- Wafer Fab
Shanghai SIM-BCD Semiconductor Manufacturing Limited
800, Yi Shan Road, Shanghai 200233, China
Tel: +86-21-6485 1491, Fax: +86-21-5450 0008

BCD Semiconductor Manufacturing Limited
- IC Design Group
Advanced Analog Circuits (Shanghai) Corporation
8F, Zone B, 900, Yi Shan Road, Shanghai 200233, China
Tel: +86-21-6495 9539, Fax: +86-21-6485 9673

REGIONAL SALES OFFICE

Shenzhen Office
Shanghai SIM-BCD Semiconductor Manufacturing Co., Ltd. Shenzhen Office
Advanced Analog Circuits (Shanghai) Corporation Shenzhen Office
27B, Tower C, 2070, Middle Shen Nan Road, Shenzhen 518031, China
Tel: +86-755-8368 3987, Fax: +86-755-8368 3166

Taiwan Office
BCD Semiconductor (Taiwan) Company Limited
4F, 298-1, Rui Guang Road, Nei-Hu District, Taipei,
Taiwan
Tel: +886-2-2656 2808, Fax: +886-2-2656 2806

USA Office
BCD Semiconductor Corporation
3170 De La Cruz Blvd., Suite 105, Santa Clara,
CA 95054-2411, U.S.A
Tel: +1-408-988 6388, Fax: +1-408-988 6386