



---

## Design Example Report

<b>Title</b>	<b><i>High Efficiency, High Power Factor, Non-Isolated Buck Boost TRIAC Dimmable 4.5 W LED Driver Using LinkSwitch™-PL LNK458KG</i></b>
<b>Specification</b>	90 VAC – 132 VAC Input; 48 V <sub>TYP</sub> , 93 mA Output
<b>Application</b>	LED Driver for B10 Lamp Replacement
<b>Author</b>	Applications Engineering Department
<b>Document Number</b>	DER-315
<b>Date</b>	March 20, 2012
<b>Revision</b>	1.1

### **Summary and Features**

- Single-stage power factor corrected combined with accurate constant current (CC) output
- Low cost, low component count, small, single-sided PCB
- TRIAC dimmable
- Highly energy efficient, >86% at 115 VAC input
- Superior performance and end user experience
  - Fast start-up time (<300 ms) – no perceptible delay
- Integrated protection and reliability features
  - Single shot no-load protection (optional self-resetting and repetitive protection)
  - Auto-recovering thermal shutdown with large hysteresis protects both components and PCB
  - No damage during brown-out
- PF >0.95 at 115 VAC
- %A THD <20% at 115 VAC
- Meets IEC ring wave, differential line surge and EN55015 conducted EMI

### **PATENT INFORMATION**

The products and applications illustrated herein (including transformer construction and circuits external to the products) may be covered by one or more U.S. and foreign patents, or potentially by pending U.S. and foreign patent applications assigned to Power Integrations. A complete list of Power Integrations' patents may be found at [www.powerint.com](http://www.powerint.com). Power Integrations grants its customers a license under certain patent rights as set forth at <http://www.powerint.com/ip.htm>.

## Table of Contents

1	Introduction.....	4
2	Power Supply Specifications .....	6
3	Schematic.....	7
4	Circuit Description .....	8
4.1	Input EMI Filtering .....	8
4.2	Power Circuit.....	8
4.3	Output Feedback.....	9
4.4	Open Load Protection .....	9
4.5	TRIAC Phase Dimming Control Compatibility .....	9
4.6	Pre-Load Circuit .....	10
5	PCB Layout .....	11
6	Bill of Materials .....	13
7	Inductor Specification .....	14
7.1	Electrical Diagram .....	14
7.2	Electrical Specifications.....	14
7.3	Materials.....	14
7.4	Inductor Build Diagram.....	15
7.5	Inductor Construction .....	15
8	Inductor Design Spreadsheet .....	16
9	Performance Data .....	18
9.1	Active Mode Efficiency .....	18
9.2	Line Regulation .....	19
9.3	Power Factor .....	20
9.4	%THD.....	21
9.5	Harmonics .....	22
9.6	Harmonic Measurements .....	23
9.7	Thermal Scans .....	24
10	Non-Dimming Waveforms.....	25
10.1	Drain Voltage and Current, Normal Operation.....	25
10.2	Drain Voltage and Current Start-up Profile .....	25
10.3	Output Voltage Start-up Profile.....	27
10.4	Input and Output Voltage and Current Profiles.....	27
10.5	Drain Voltage and Current Profile with Output Shorted .....	28
10.6	Line Transient Response.....	29
10.7	Brown-out.....	30
10.8	Disconnected Load.....	30
10.9	Line Surge Waveform.....	31
11	Dimming Performance .....	33
11.1	Compatibility Table .....	33
11.2	NEMA Compliance .....	34
12	Dimming Waveforms.....	35
12.1	Lutron TGLV-600PR Dimmer .....	35
12.2	Leviton 6615-POW Dimmer.....	36
12.3	Lutron MAELV-600 Dimmer .....	37



12.4	Lutron S-600 Dimmer .....	38
12.5	Lutron S-600P Dimmer .....	39
12.6	Lutron Skylark S-600-PR Dimmer.....	40
12.7	Cooper S106P Dimmer.....	41
12.8	Lutron MAW-600 Dimmer .....	42
12.9	Lutron MIR-600 Dimmer .....	43
13	Line Surge .....	44
14	Conducted EMI .....	45
14.1	Equipment .....	45
14.2	EMI Test Set-up.....	45
14.3	EMI Test Result .....	46
15	Revision History .....	47

**Important Note:**

Although this board is designed to satisfy safety requirements for non-isolated LED drivers, the engineering prototype has not been agency approved. Therefore, all testing should be performed using an isolation transformer to provide the AC input to the prototype board.



## 1 Introduction

This document is an engineering report describing a non-isolated, high-efficiency, high power factor, TRIAC dimmable LED driver designed to drive a nominal LED string voltage of 48 V at 93 mA (4.5 W). Input voltage range is 90 VAC to 132 VAC (47 Hz - 63 Hz). This LED driver utilizes LNK458KG from the LinkSwitch-PL family of devices.

LinkSwitch-PL based designs provide a high power factor ( $>0.9$ ) meeting international requirements.

The form factor of the board was chosen to meet the requirements for standard B10 LED replacement lamps. The output is non-isolated and requires the mechanical design of the enclosure to isolate the output of the supply and the LED load from the user.

The document contains the power supply specification, schematic, bill of materials, transformer documentation, printed circuit layout, design spreadsheet and performance data.



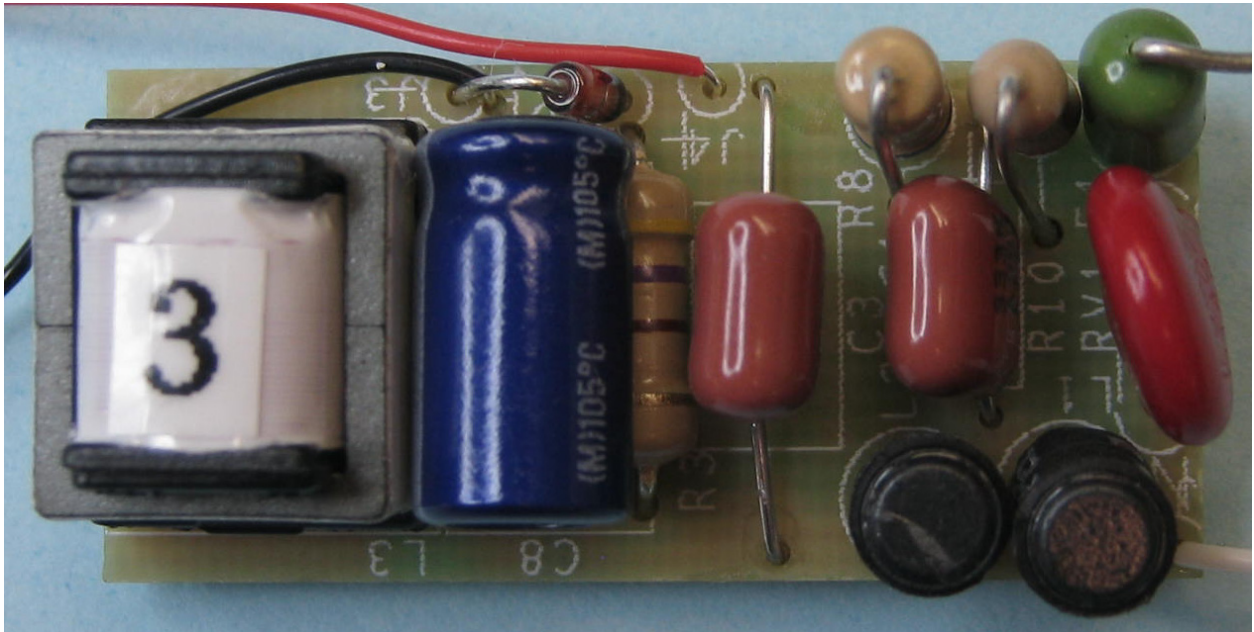


Figure 1 – Populated Circuit Board, Top View.

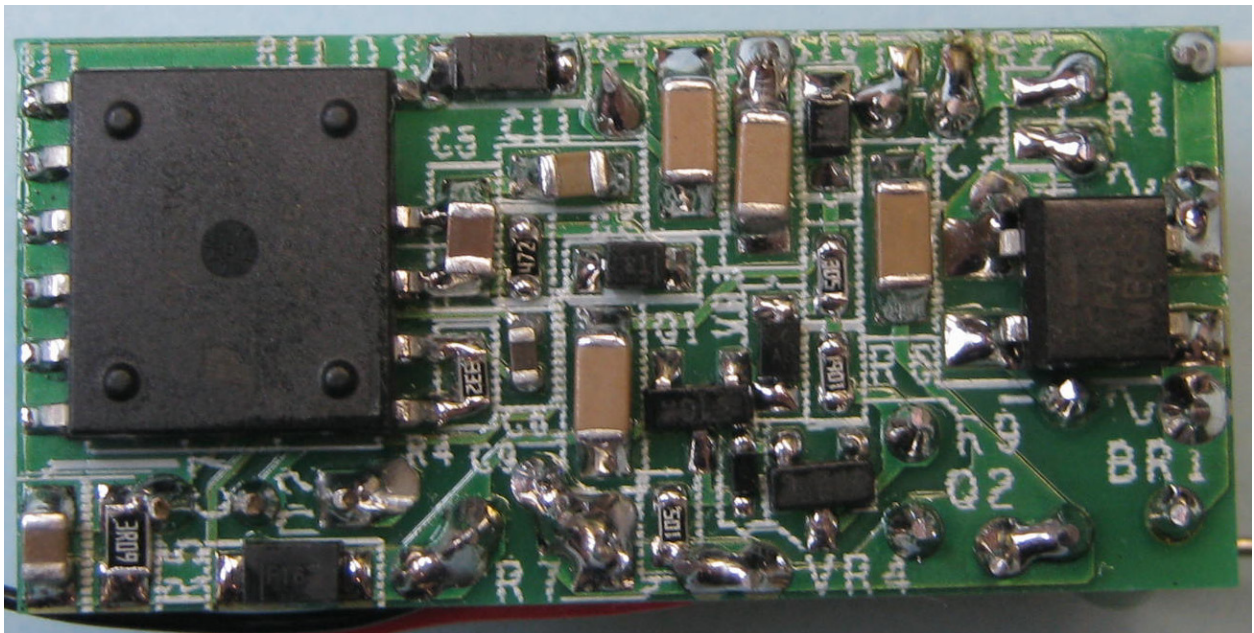


Figure 2 – Populated Circuit Board, Bottom View.



## 2 Power Supply Specifications

The table below represents the minimum acceptable performance required for the design. Actual performance is listed in the results section.

Description	Symbol	Min	Typ	Max	Units	Comment
<b>Input</b>						
Voltage	$V_{IN}$	90	115	132	VAC	2 Wire – no P.E.
Frequency	$f_{LINE}$	47	50/60	63	Hz	
Power Factor		0.95				At 115 VAC
%ATHD				20		At any line input voltage
<b>Output</b>						
Output Voltage	$V_{OUT}$		48		V	
Output Current	$I_{OUT}$	87	93	97	mA	
<b>Total Output Power</b>						
Continuous Output Power	$P_{OUT}$		4.5		W	
<b>Efficiency</b>						
Nominal	$\eta$	86			%	Measured at $P_{OUT}$ 25 °C at 115 VAC
<b>Environmental</b>						
Conducted EMI		Meets CISPR22B / EN55015				
Line Surge Differential Mode (L1-L2)			0.5		kV	1.2/50 $\mu$ s surge, IEC 1000-4-5, Series Impedance: Differential Mode: 2 $\Omega$
Ring Wave (100 kHz) Differential Mode (L1-L2)			2.5		kV	2 $\Omega$ short-circuit Series Impedance
Harmonic Currents		EN 61000-3-2 Class D (C)				Class C specifies Class D Limits when $P_{IN} < 25$ W



### 3 Schematic

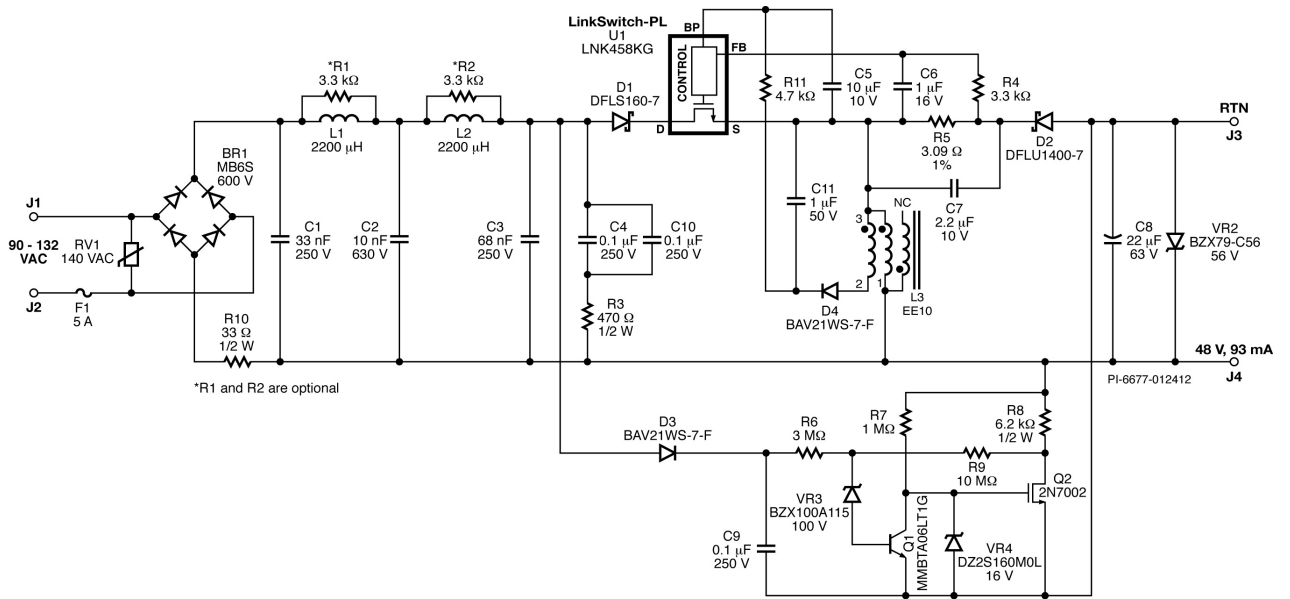


Figure 3 – Schematic.



## 4 Circuit Description

The LinkSwitch-PL (U1) is a highly integrated primary-side controller intended for use in LED driver applications. The LinkSwitch-PL provides high power factor in a single-stage conversion topology while regulating the output current across a range of input (90 VAC - 132 VAC) and output voltage variations typically encountered in LED driver applications. All of the control circuitry responsible for these functions plus the high-voltage power MOSFET is incorporated into the IC.

### 4.1 Input EMI Filtering

Fuse F1 provides protection against component failure. A 5 A rating was selected to prevent false opening during line surges. Varistor RV1 provides a clamp to limit the voltage during differential line surge. A 140 VAC part is chosen which is slightly above the maximum operating voltage of 132 VAC.

The AC input is full wave rectified by BR1.

Inductor L1 and L2, and capacitors C1, C2, and C3 provide EMI filtering. This two-stage  $\pi$ -filter network plus the frequency jittering feature of LinkSwitch-PL allows compliance with Class B emission limits. Resistor R1 and R2 are used to damp the resonance of the EMI filter, preventing peaks in the conducted EMI spectrum when measured in a system (driver plus enclosure).

- Inductor L1 and L2 are positioned after the bridge to avoid an imbalance in EMI between line and neutral.
- The values of C1, C2, and C3 are optimized to meet EMI requirements but low enough in value to maintain high power factor.

### 4.2 Power Circuit

The buck boost power train is composed of U1 (power switch + control), D2 (free-wheeling diode), C8 (output capacitor), and L3 (inductor). Diode D1 is used to prevent a negative voltage appearing across the drain-source of U1 especially near the zero-crossing of the input voltage.

The bypass capacitor C5 provides the internal supply for the device when the power MOSFET is on. However, an external bias voltage is necessary to maintain IC operation during deep dimming. This is achieved via an extra winding - configured as flyback - added to L3. Diode D4 and C11 provide rectification and filtering while R11 limits the current flowing to the BYPASS (BP) pin to just above the required IC supply current. This circuit also improves overall efficiency.

- Diode D1 is a low drop Schottky type diode to maximize efficiency. It may be replaced with an ultrafast PN type for lower cost with a 0.2% reduction in efficiency in cost sensitive designs.





- Inductor L3 winding construction and wire gauge are optimized to minimize inter-winding capacitance and to reduce AC losses.

### **4.3 Output Feedback**

The output current feedback is sensed via the voltage drop across R5 and then filtered by a low pass filter (R4 and C6). The values are such that the average FEEDBACK (FB) pin voltage is 290 mV in steady-state operation. Capacitor C7 is used to filter the high frequency component of the diode current and helps improve overall efficiency by reducing the RMS loss in R5.

### **4.4 Open Load Protection**

The LED driver is protected by Zener diode VR2 in the event of accidental disconnected (open) load operation. The diode will short the output if the load is not connected and U1 will enter auto-restart. This type of protection is not auto-recovering and the diode must be replaced in order to reuse the LED driver. Note that at system level the LED load is always connected. If the system will be potted or enclosed tightly, VR1 may not be required.

### **4.5 TRIAC Phase Dimming Control Compatibility**

The requirement to provide output dimming with low cost, TRIAC based, leading-edge phase dimmers introduced a number of trade-offs in the design.

Due to the much lower power consumed by LED based lighting, the current drawn by the lamp during dimming is below the holding current of the TRIAC within many dimmers. This causes undesirable behavior - limited dimming range and/or flickering when the TRIAC fires inconsistently. The relatively large impedance presented to the line by the LED driver allows significant ringing to occur due to the inrush current charging the input capacitance when the TRIAC turns on. This effect can cause similar undesirable behavior, as the ringing may cause the TRIAC current to fall to zero and turn off prematurely.

To overcome these issues, a passive damper and passive bleeder were incorporated. The drawback of these circuits is increased dissipation and therefore reduced efficiency of the supply. For non-dimming application these components can simply be omitted.

The passive damper consists of resistor R10. This limits the peak input current when the TRIAC turns on, reducing input current ringing due to line inductance.

The passive bleeder circuit is comprised of C4, C10 and R3. This increases the input current (regularly above the TRIAC holding current) as the input current increases during each AC half-cycle. This prevents the TRIAC from turning on and off at the start of the conduction angle.

Due to the size constraint of the enclosure, the power dissipation of the bleeder was limited to a single 0.5 W resistor. This means that in some cases multiple parallel lamps



to be connected to a single dimmer for correct operation (Section 11). Alternatively, the bleeder current may be increased (increase C4 and C10, decrease R3) at expense of a larger PCB size.

#### 4.6 Pre-Load Circuit

A pre-load circuit was added to prevent the LED from periodically flashing when the TRIAC is off. Ideally, no voltage will pass through the TRIAC if it is in OFF mode, however, some TRIAC dimmers allow a small leakage current to flow even when held off. This current would cause the input capacitor to charge and allow U1 to operate periodically pumping up the output capacitor, eventually biasing on the LED load.

To prevent this, a pre-load was added. A simple resistor across the output could perform this function, but the 0.4 W dissipation during normal operation was deemed too high. Therefore a pre-load disconnect was added to disable the pre-load during normal operation.

The circuit works by sensing the peak DC bus voltage through a peak detector circuit using diode D3 and capacitor C9. Resistor R8 acts as a pre-load connected across the output terminals. Resistors R6 and R8 provide hysteresis to prevent false triggering of the pre-load circuit.



### 5 PCB Layout

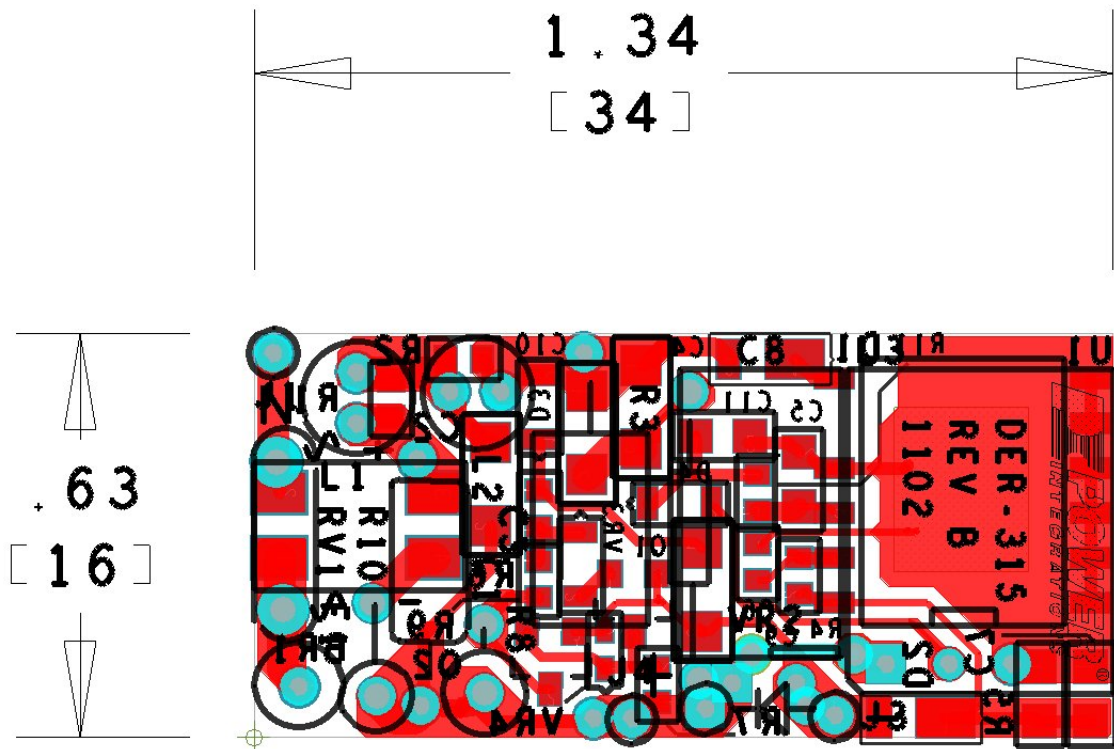


Figure 4 – PCB Layout and Outline.

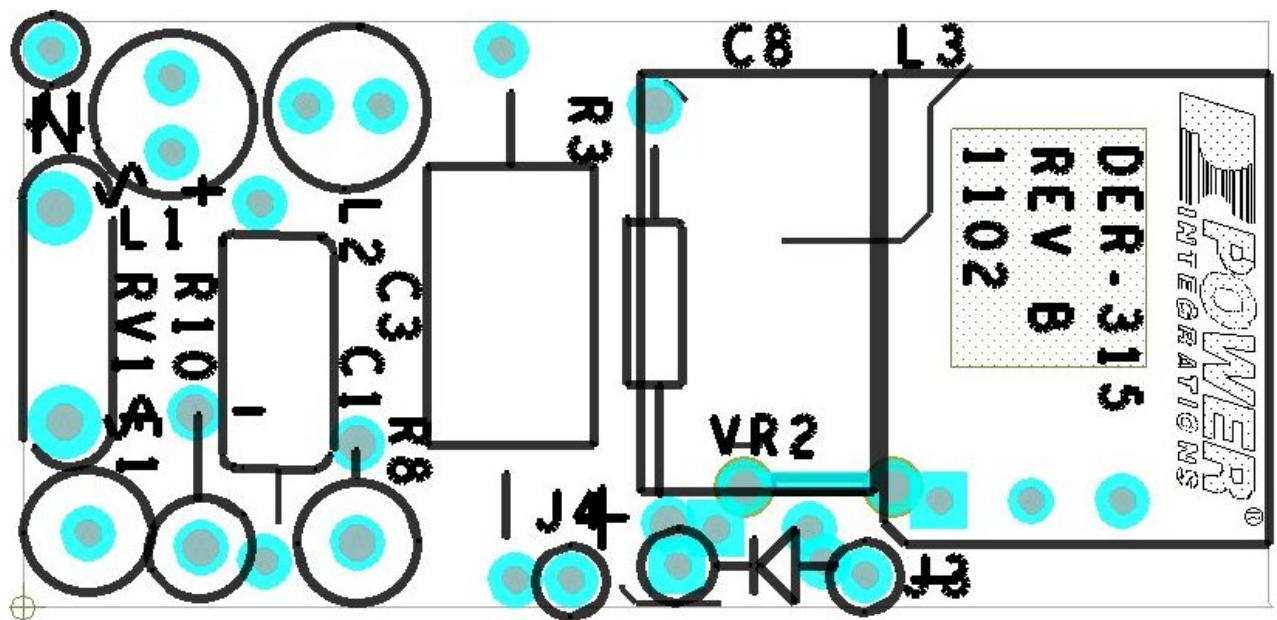


Figure 5 – Top Printed Circuit Layout.



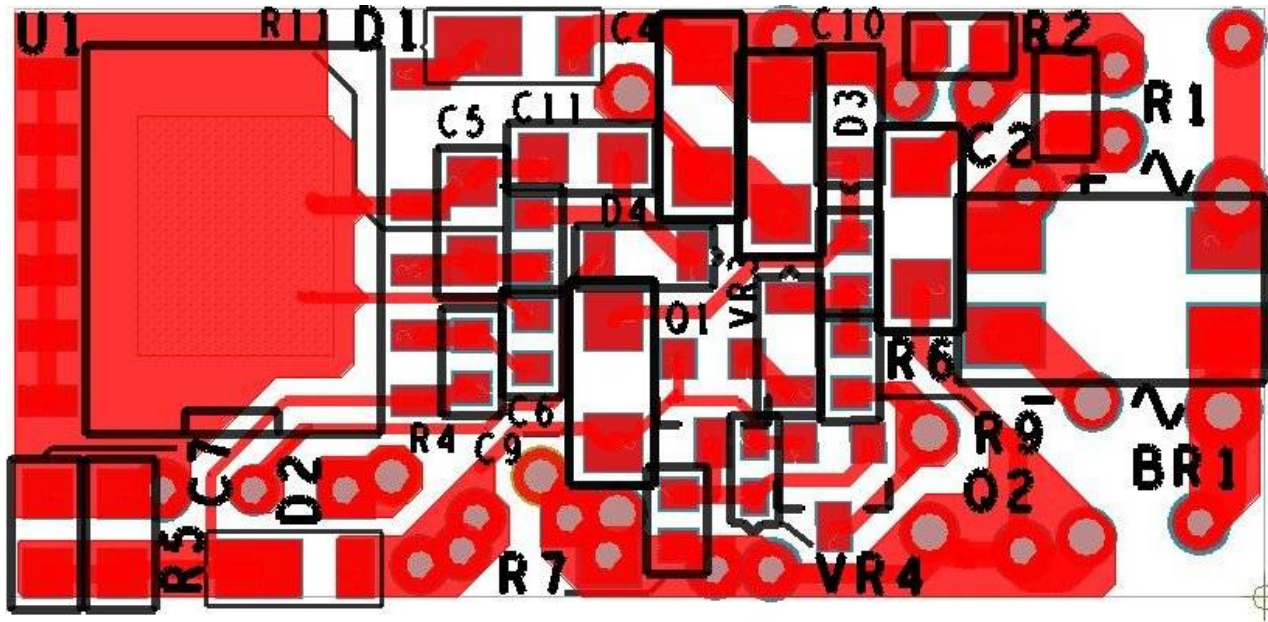


Figure 6 – Bottom Printed Circuit Layout.



## 6 Bill of Materials

Item	Qty	Ref Des	Description	Mfg Part Number	Manufacturer
1	1	BR1	600 V, 0.5 A, Bridge Rectifier, SMD, MBS-1, 4-SOIC	MB6S-TP	Micro Commercial
2	1	C1	33 nF, 250 V, Film	ECQ-E2333KB	Panasonic
3	1	C2	10 nF, 630 V, Ceramic, X7R, 1206	C1206C103KBRACTU	Kemet
4	1	C3	68 nF, 250 V, Polyester Film	ECQ-E2683KB	Panasonic
5	3	C4 C9 C10	0.1 $\mu$ F, 250 V, Ceramic, X7R, 1206	C3216X7R2E104M	TDK
6	1	C5	10 $\mu$ F, 10 V, Ceramic, X7R, 0805	C2012X7R1A106M	TDK
7	1	C6	1 $\mu$ F 16 V, Ceramic, X7R, 0603	C1608X7R1C105M	TDK
8	1	C7	2.2 $\mu$ F, 10 V, Ceramic, X7R, 0805	GRM21BR71A225MA01L	Murata
9	1	C8	22 $\mu$ F, 63, Electrolytic, Low ESR, 1000 m $\Omega$ , (6.3 x 11.5)	ELXZ630ELL220MFB5D	Nippon Chemi-Con
10	1	C11	1 $\mu$ F, 50 V, Ceramic, X7R, 0805	C2012X7R1H105M	TDK
11	1	D1	60 V, 1 A, Diode Schottky, PWRDI 123	DFLS160-7	Diodes, Inc.
12	1	D2	400 V, 1 A, Diode Sup Fast 1A PWRDI 123	DFLU1400-7	Diodes, Inc.
13	2	D3 D4	250 V, 0.2 A, Fast Switching, 50 ns, SOD-323	BAV21WS-7-F	Diodes, Inc.
14	1	F1	5 A, 250 V, Fast, Microfuse, Axial	0263005.MXL	Littlefuse
15	4	J1 J2 J3 J4	PCB Terminal Hole, #30 AWG	N/A	N/A
16	2	L1 L2	2.2 mH, 0.046 A, 20%	RL-5480-1-2200	Renco
17	1	L3	Bobbin, EE10, Horizontal, 8 pins	EE10-8P-1S	Kunshan Fengshunhe
18	1	Q1	NPN, Small Signal BJT, 80 V, 0.5 A, SOT-23	MMBTA06LT1G	On Semi
19	1	Q2	MOSFET N-CH 60V 115MA SOT23-3	2N7002-7-F	Diodes, Inc.
20	3	R1 R2 R4	3.3 k $\Omega$ , 5%, 1/10 W, Thick Film, 0603	ERJ-3GEYJ332V	Panasonic
21	1	R3	470 $\Omega$ , 5%, 1/2 W, Carbon Film	CFR-50JB-470R	Yageo
22	1	R5	3.09 $\Omega$ , 1%, 1/8 W, Thick Film, 0805	RC0805FR-073R09L	Yageo
23	1	R6	3 M $\Omega$ , 5%, 1/10 W, Thick Film, 0603	ERJ-3GEYJ305V	Panasonic
24	1	R7	1 M $\Omega$ , 5%, 1/10 W, Thick Film, 0603	ERJ-3GEYJ105V	Panasonic
25	1	R8	6.2 k $\Omega$ , 5%, 1/2 W, Carbon Film	CFR-50JB-6K2	Yageo
26	1	R9	10 M $\Omega$ , 5%, 1/10 W, Thick Film, 0603	ERJ-3GEYJ106V	Panasonic
27	1	R10	33 $\Omega$ , 5%, 1/2 W, Carbon Film	CFR-50JB-33R	Yageo
28	1	R11	4.7 k $\Omega$ , 5%, 1/10 W, Thick Film, 0603	ERJ-3GEYJ472V	Panasonic
29	1	RV1	140 V, 12 J, 7 mm, RADIAL	V140LA2P	Littlefuse
30	1	U1	LinkSwitch-PL, eSOP-12P	LNK458KG	Power Integrations
31	1	VR2	56 V, 500 mW, 5%, DO-35	BZX79-C56	Taiwan Semi
32	1	VR3	100 V, 5%, 310 mW, SOD-323	BZX100A,115	NXP
33	1	VR4	16 V, 5%, 150 mW, SSMINI-2	DZ2S160M0L	Panasonic



## 7 Inductor Specification

### 7.1 Electrical Diagram

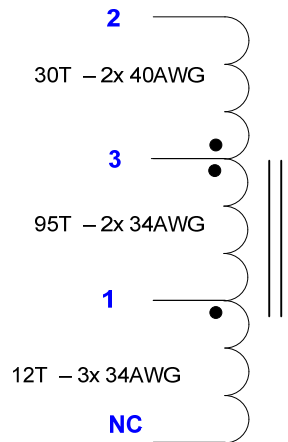


Figure 7 – 48 V Inductor Electrical Diagram.

### 7.2 Electrical Specifications

<b>Primary Inductance</b>	Pins 1-3, all other windings open, measured at 100 kHz, 0.4 V <sub>RMS</sub>	500 $\mu$ H $\pm$ 5%
---------------------------	--	----------------------

### 7.3 Materials

Item	Description
[1]	Core: EE10/PC40
[2]	Bobbin: EE10, Horizontal, 8 pins, (4/4), Taiwan Shulin Enterprise Co., Ltd. or Kunshan Fengshunhe Electronics Co., Ltd Equivalent
[3]	Magnet Wire: 3 x #34 AWG
[4]	Magnet Wire: 2 x #40 AWG
[5]	Magnet Wire: 2 x #34 AWG
[6]	Loctite Super Glue Control Gel



### 7.4 Inductor Build Diagram

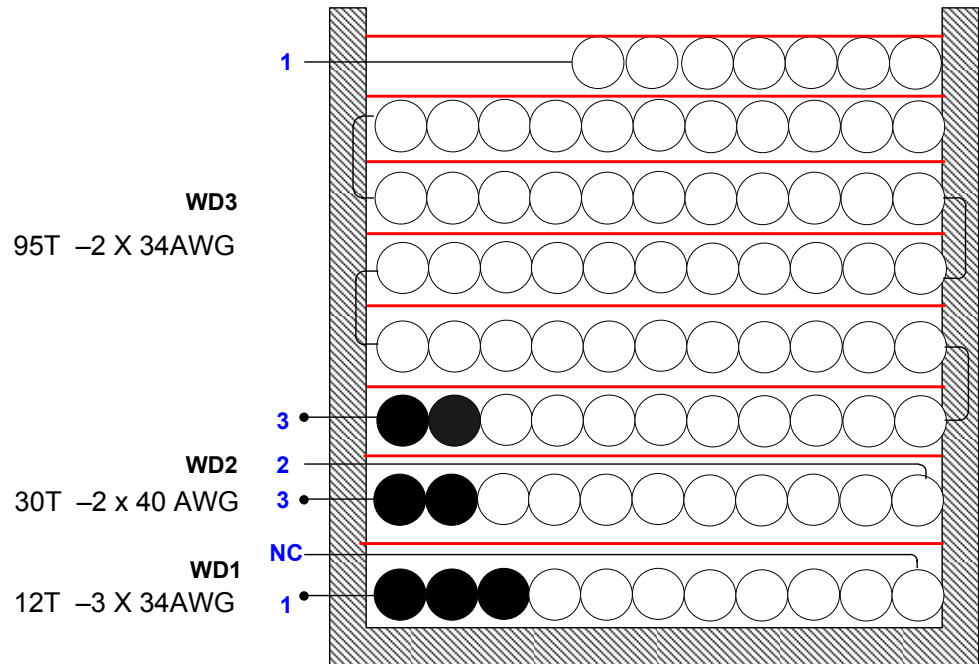


Figure 8 – Inductor Build Diagram.

### 7.5 Inductor Construction

<b>General Note</b>	For the purpose of these instructions, bobbin is oriented on winder such that pin 1 side is on the left (Figure 10). Winding direction is counter-clockwise.
<b>WD1</b>	Start at pin 1. Wind 12 turns of item [3] as shown in Figure 8. Leave the end windings unterminated Add 1 layer of tape.
<b>WD2</b>	Start at pin 3. Wind 30 turns of item [4] and terminate the other end at pin 2. Add 1 layer of tape.
<b>WD3</b>	Start at pin 3. Wind enough turns of item [5] as shown in Figure 8 with 1 layer of tape between the windings. Continue winding and terminate at pin 1. Note: eliminating the tape between layers will increase capacitance and reduce driver efficiency.
<b>Finish</b>	Grind the core to get the specified inductance. Apply tape to secure both cores. Cut pins 4, 5, 6, 7 and 8. Apply adhesive item [6] to core and bobbin to prevent core movement.

## 8 Inductor Design Spreadsheet

	INPUT	INFO	OUTPUT	UNIT	DESIGN TITLE
<b>ENTER APPLICATION VARIABLES</b>					
VACMIN	90		90	V	Minimum AC input voltage
VACNOM	115		115	V	Nominal AC input voltage
VACMAX	132		132	V	Maximum AC input voltage
FL	60		60	Hz	Minimum line frequency
VO_MIN	42.00		42.0	V	Minimum output voltage tolerance
VO_NOM	48.00		48.0	V	Nominal Output Voltage
VO_MAX	54.00		54.0	V	Maximum output voltage tolerance
IO	0.093		0.093	A	Average output current specification
n	0.85		0.850	%/100	Total power supply efficiency
Z			0.5		Loss allocation factor
Enclosure	Retrofit Lamp		Retrofit Lamp		Enclosure selections determines thermal conditions and maximum power
PO			4.46	W	Total output power
VD	0.50		0.5	V	Output diode forward voltage drop
<b>LinkSwitch-PL DESIGN VARIABLES</b>					
Device	LNK458		LNK458		Chosen LinkSwitch-PL Device
TON			1.84	us	Expected on-time of MOSFET at low line and PO
FSW			107.3	kHz	Expected switching frequency at low line and PO
Duty Cycle			19.8	%	Expected operating duty cycle at low line and PO
VDRAIN			261	V	Estimated worst case drain voltage at VACMAX and VO_MAX
IRMS			0.110	A	Nominal RMS current through the switch
IPK			0.691	A	Worst Case Peak current
ILIM_MIN			1.012	A	Minimum device current limit
KDP	1.22		1.21		Ratio between off-time of switch and reset time of core at VACNOM
<b>LinkSwitch-PL EXTERNAL COMPONENT CALCULATIONS</b>					
RSENSE			3.118	Ohms	Output current sense resistor
Standard RSENSE			3.09	Ohms	Closest 1% value for RSENSE
PSENSE			27.0	mW	Power dissipated by RSENSE
<b>ENTER TRANSFORMER CORE/CONSTRUCTION VARIABLES</b>					
Core Type	EE10		EE10		Core Type
Core Part Number			Custom		Core Part Number (if Available)
Bobbin Part Number			Custom		Bobbin Part Number (if available)
AE	12.10		12.10	mm <sup>2</sup>	Core Effective Cross Sectional Area
LE	26.10		26.10	mm	Core Effective Path Length
AL	850		850	nH/T <sup>2</sup>	Ungapped Core Effective Inductance
BW	6.00		6	mm	Bobbin Physical Winding Width
L	5		5		Number of winding layers
<b>TRANSFORMER PRIMARY DESIGN PARAMETERS</b>					
LP			495.7	uH	Primary Inductance
LP Tolerance	5.00		5	%	Tolerance of Primary Inductance
N	95		95	Turns	Number of Turns
ALG			55	nH/T <sup>2</sup>	Gapped Core Effective Inductance
BM			2979	Gauss	Operating Flux Density
BAC			1490	Gauss	Worst case AC Flux Density for Core Loss Curves (0.5 X Peak to Peak)





BP		<i>Warning</i>	5832	Gauss	!!! Reduce peak flux density (BP < 3600 G) by increasing NP, selecting a bigger core or decreasing KDP
LG			0.277	mm	Gap Length (Lg > 0.1 mm)
BWE			30	mm	Effective Bobbin Width
L_IRMS			0.257	A	RMS Curren through the inductor
OD			0.32	mm	Maximum Primary Wire Diameter including insulation
INS			0.05	mm	Estimated Total Insulation Thickness (= 2 * film thickness)
DIA			0.26	mm	Bare conductor diameter
AWG			30	AWG	Primary Wire Gauge (Rounded to next smaller standard AWG value)
CM			102	Cmils	Bare conductor effective area in circular mils
CMA			395	Cmils/Amp	Primary Winding Current Capacity (200 < CMA < 500)
Current Density (J)			5.04	A/mm <sup>2</sup>	Inductor Winding Current density (3.8 < J < 9.75 A/mm <sup>2</sup> )
<b>OUTPUT PARAMETERS</b>					
IRIPPLE?					Maximum Capacitor Ripple Current
IO			0.093	A	Expected Output Current
PIVS			265.3	V	Peak Inverse Voltage at VO_MAX on output diode

Note: Peak flux density is limited by slowly increasing the duty cycle of LinkSwitch-PL family during start-up. No core saturation occurred when tested for start-up short, running-short, with the core temperature raised to 100 °C.



## 9 Performance Data

All measurements performed at 25 °C room temperature, 60 Hz input frequency unless otherwise specified.

### 9.1 Active Mode Efficiency

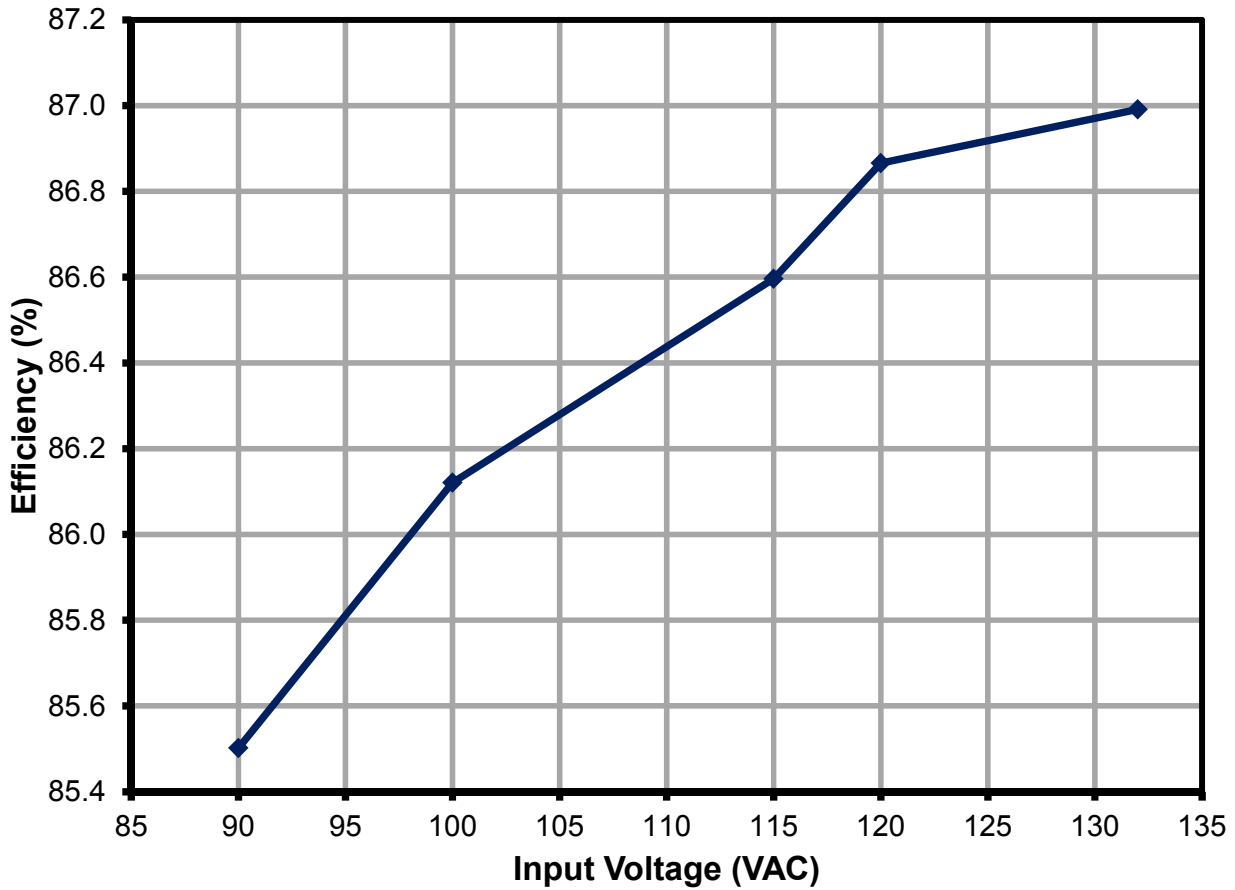


Figure 9 – Efficiency with Respect to AC Input Voltage.



## 9.2 Line Regulation

The LinkSwitch-PL device regulates the output by controlling the power MOSFET on-time and switching frequency to maintain the average FB pin at its 0.29 V threshold. Slight changes in output current may be observed when input or output conditions are changed or after AC cycling due to the device selecting a slightly different operating state (selection of on-time and frequency by device).

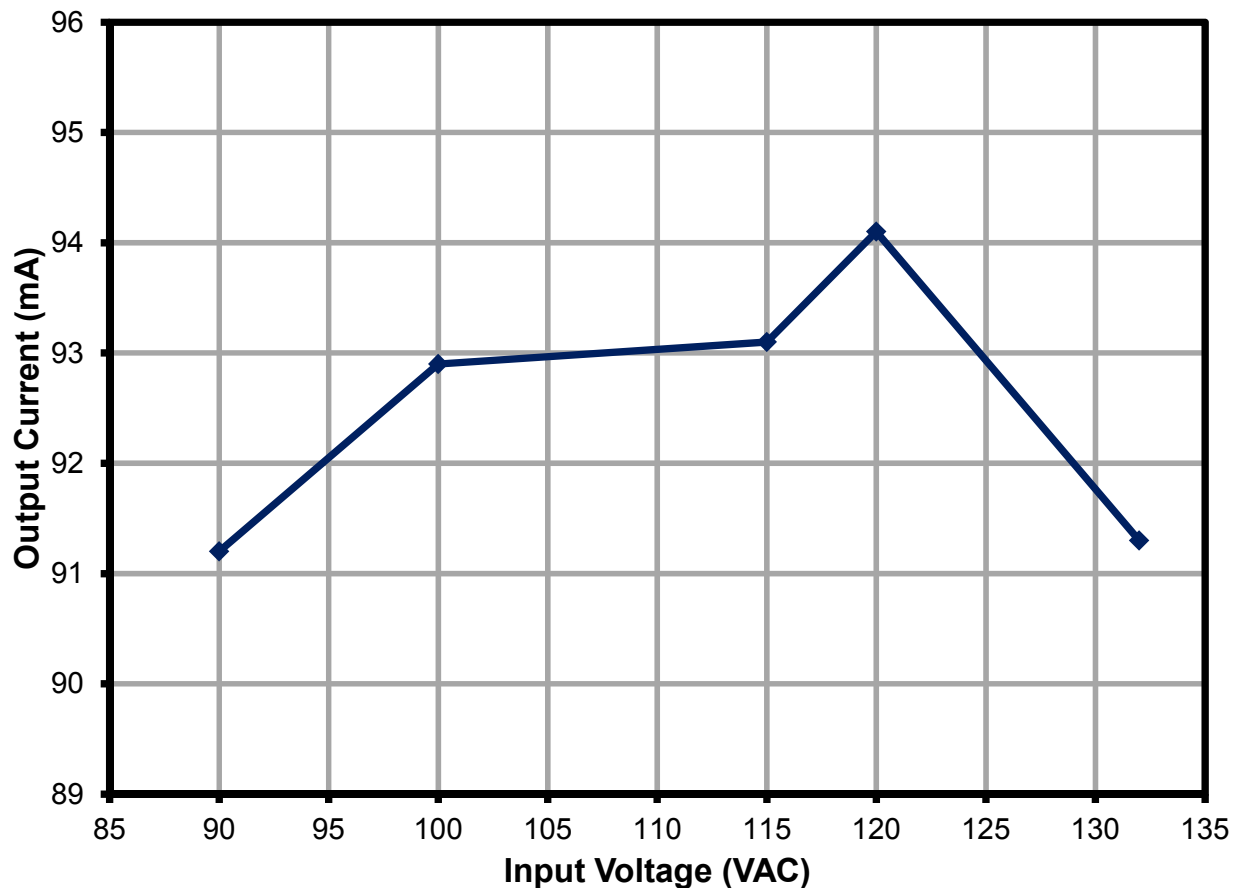


Figure 10 – Line Regulation, Room Temperature.



### 9.3 Power Factor

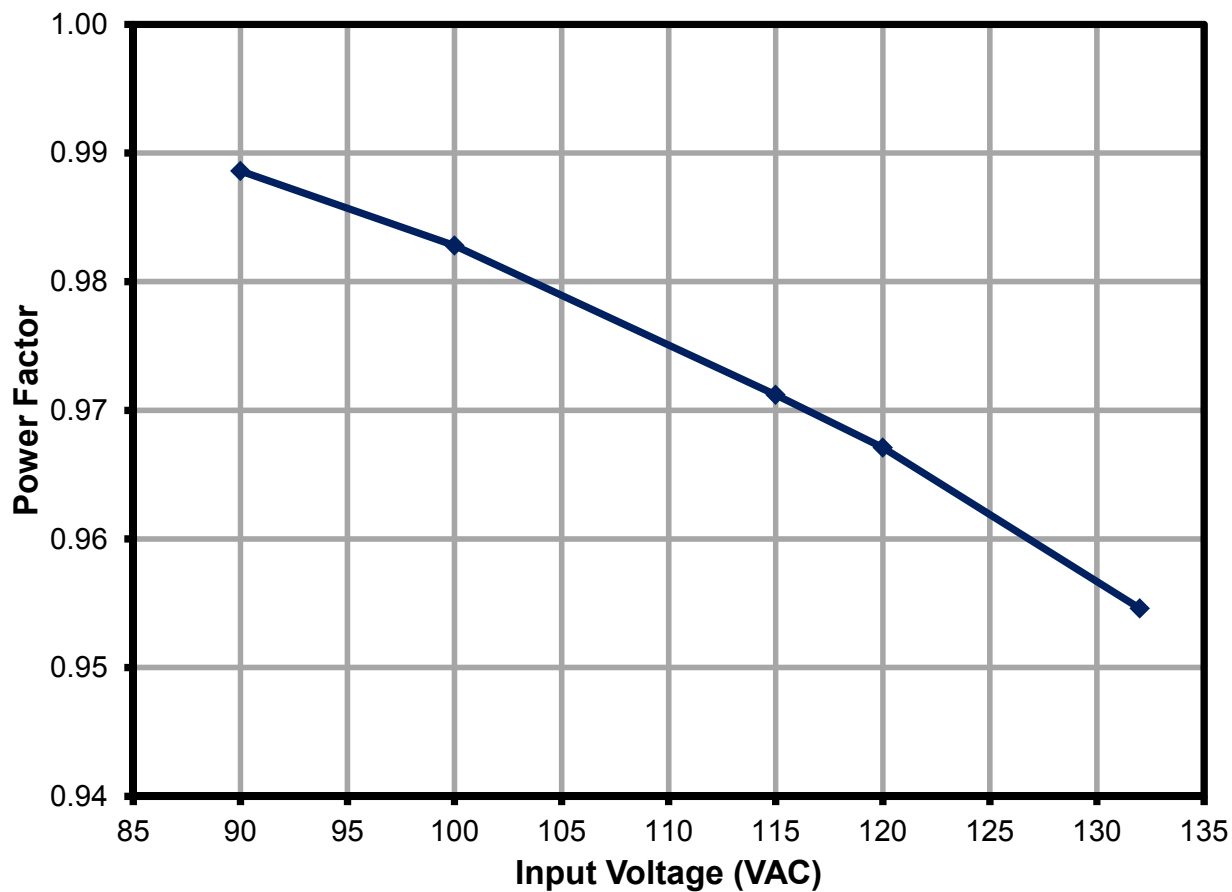


Figure 11 – High Power Factor Within the Operating Range.



9.4 %THD

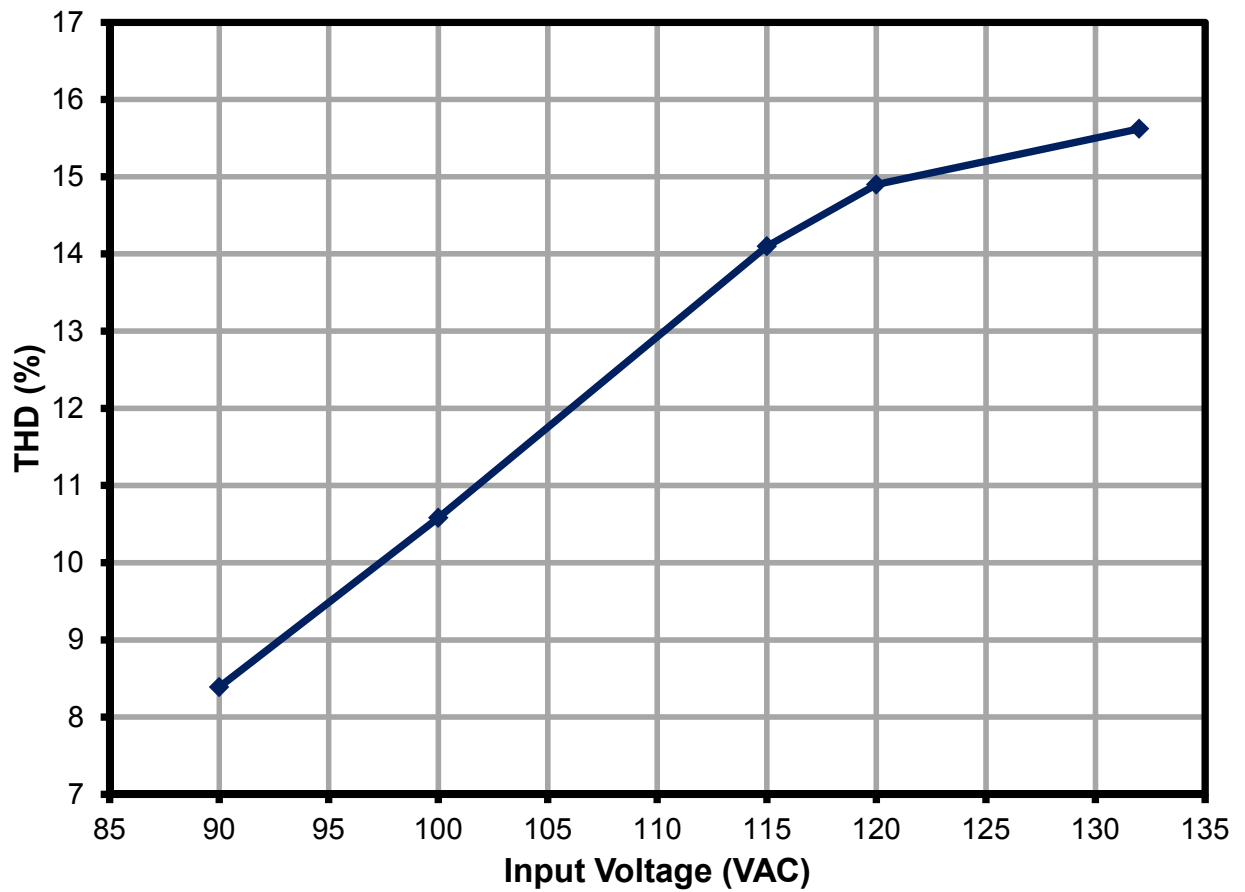


Figure 12 – Very Low %ATHD Within the Operating Range.



### 9.5 Harmonics

The design met the limits for Class C equipment for an active input power of <25 W. In this case IEC61000-3-2 specifies that harmonic currents shall not exceed the limits of Class D equipment<sup>1</sup>. Therefore the limits shown in the charts below are Class D limits which must not be exceeded to meet Class C compliance.

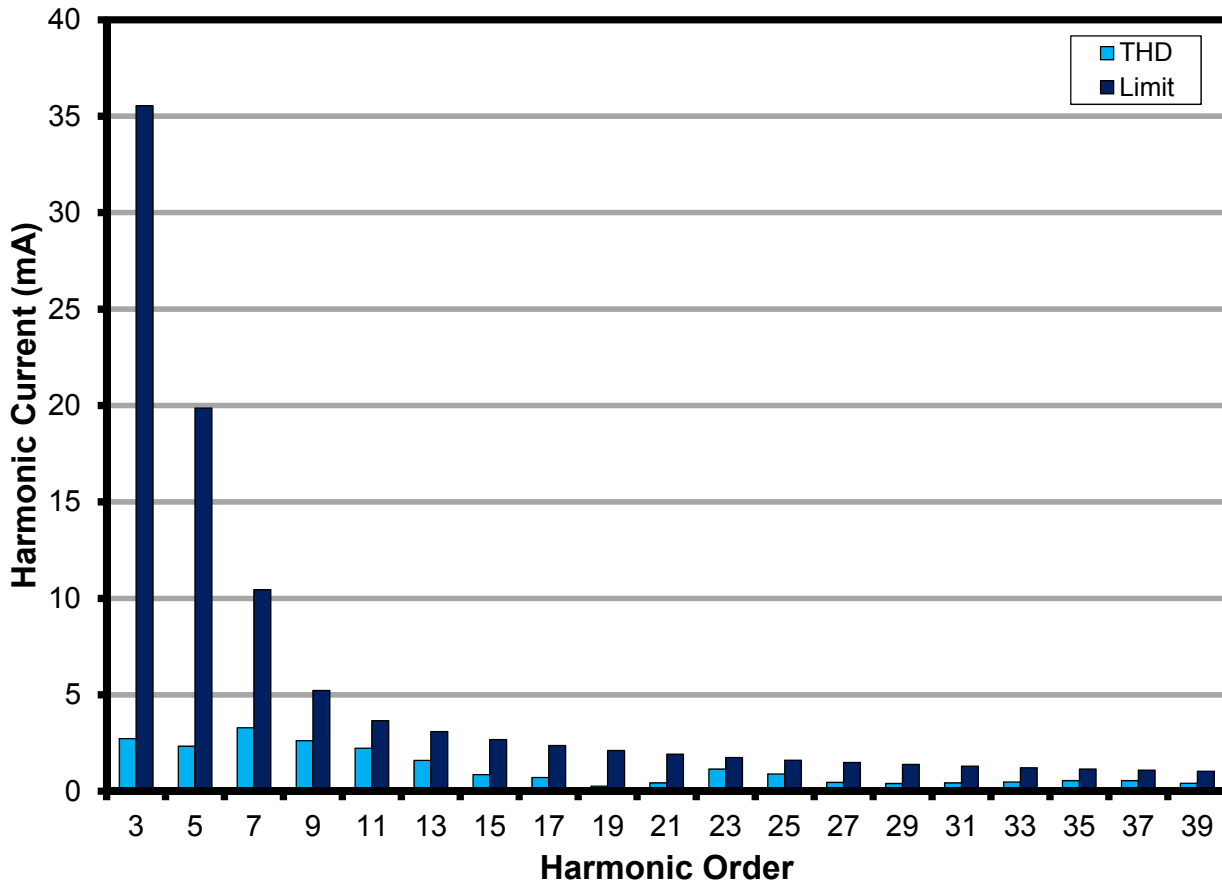


Figure 13 – Meets EN61000-3-2 Harmonics Contents Standards for <25 W Rating.

<sup>1</sup> IEC6000-3-2 Section 7.3, table 2, column 2.



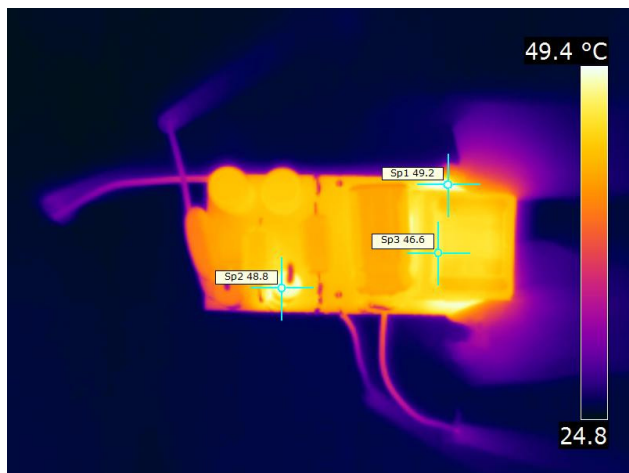
### 9.6 Harmonic Measurements

V	Freq	I (mA)	P	PF
115	60.00	45.10	5.2276	0.9671
nth Order	mA Content	% Content	Limit <25 W	Remarks
1	44.55			
2	0.06	0.13%		
3	2.73	6.13%	35.5477	Pass
5	2.34	5.25%	19.8649	Pass
7	3.29	7.39%	10.4552	Pass
9	2.63	5.90%	5.2276	Pass
11	2.23	5.01%	3.6593	Pass
13	1.60	3.58%	3.0963	Pass
15	0.86	1.93%	2.6835	Pass
17	0.71	1.59%	2.3678	Pass
19	0.27	0.59%	2.1186	Pass
21	0.44	0.98%	1.9168	Pass
23	1.15	2.58%	1.7501	Pass
25	0.90	2.02%	1.6101	Pass
27	0.47	1.04%	1.4908	Pass
29	0.40	0.90%	1.3880	Pass
31	0.44	0.98%	1.2985	Pass
33	0.48	1.08%	1.2198	Pass
35	0.56	1.25%	1.1501	Pass
37	0.55	1.23%	1.0879	Pass
39	0.41	0.93%	1.0321	Pass



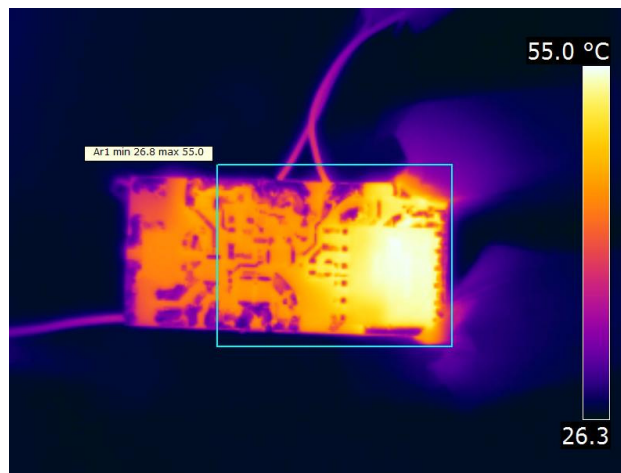
## 9.7 Thermal Scans

The scan is conducted at ambient temperature of 25 °C, 90 VAC / 60 Hz input.



**Figure 14 – Top Side.**

Sp1 (PCB Below L3): 49.2 °C.  
Sp2 (R10): 48.8 °C.  
Sp3 (L3): 46.6 °C.



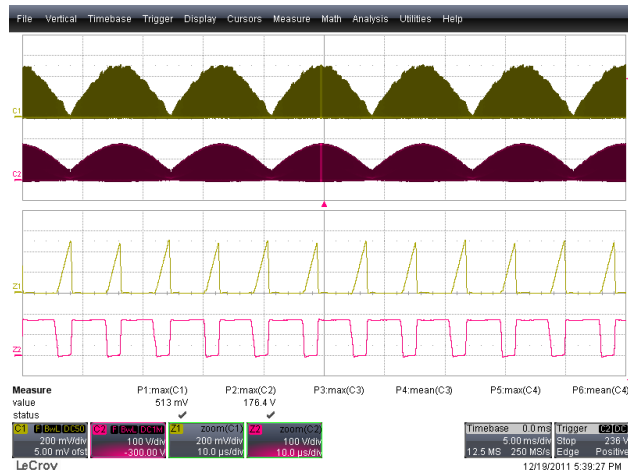
**Figure 15 – Bottom Side.**

Hottest Component: U1, 55.0 °C.

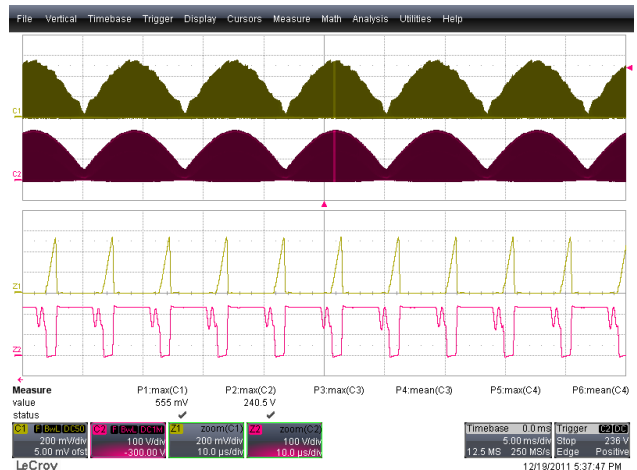


## 10 Non-Dimming Waveforms

### 10.1 Drain Voltage and Current, Normal Operation

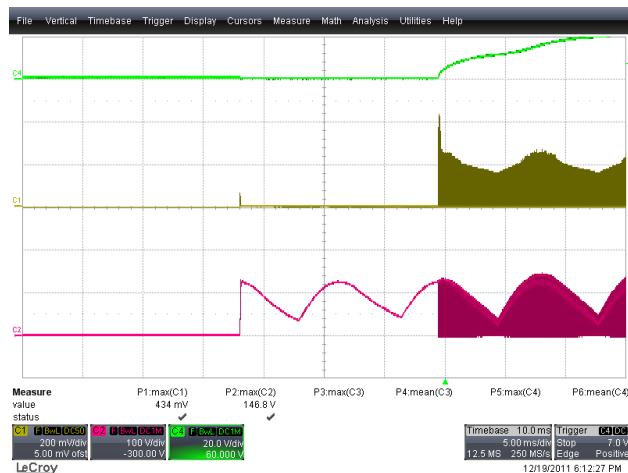


**Figure 16** – 90 VAC / 60 Hz, 48 V LED String.  
 Ch1:  $I_{DRAIN}$ , 0.2 A / div.  
 Ch2:  $V_{DRAIN}$ , 100 V / div.  
 Time Scale: 5 ms / div.  
 Zoom Time Scale: 10  $\mu$ s / div.

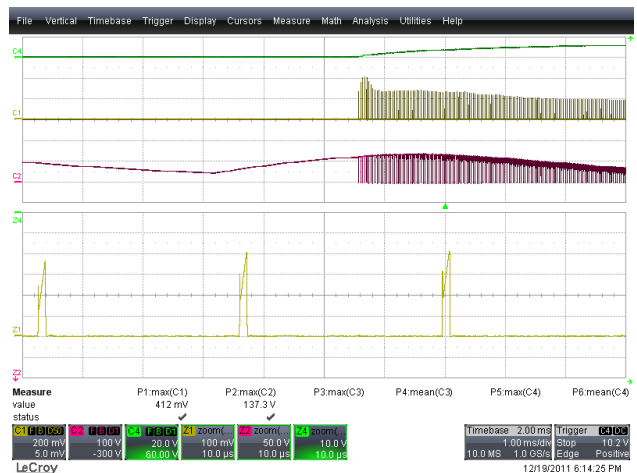


**Figure 17** – 132 VAC / 60 Hz, 48 V LED String.  
 Ch1:  $I_{DRAIN}$ , 0.2 A / div.  
 Ch2:  $V_{DRAIN}$ , 100 V / div.  
 Time Scale: 5 ms / div.  
 Zoom Time Scale: 10  $\mu$ s / div.

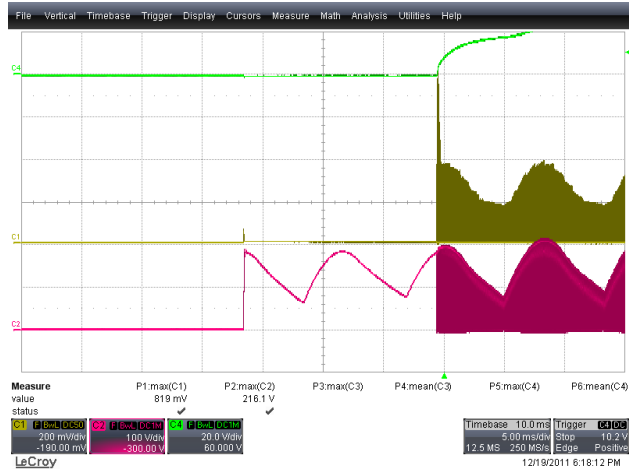
### 10.2 Drain Voltage and Current Start-up Profile



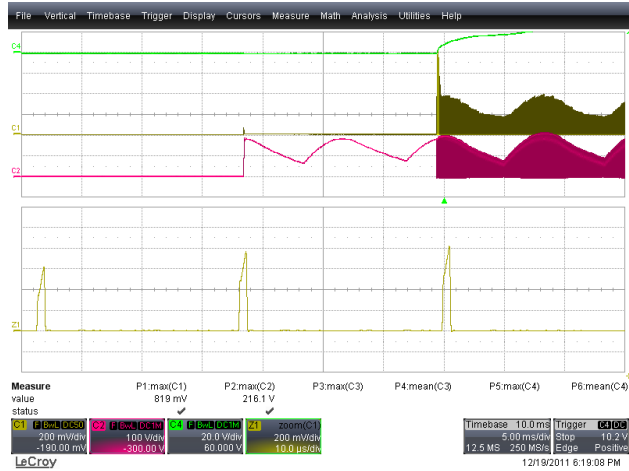
**Figure 18** – 90 VAC / 60 Hz, 48 V LED String.  
 Ch1:  $I_{DRAIN}$ , 0.2 A / div.  
 Ch2:  $V_{DRAIN}$ , 100 V / div.  
 Time Scale: 5 ms / div.



**Figure 19** – 90 VAC / 60 Hz, 48 V LED String.  
 Ch1:  $I_{DRAIN}$ , 0.2 A / div.  
 Ch2:  $V_{DRAIN}$ , 100 V / div.  
 Time Scale: 1 ms / div.  
 Zoom Time Scale: 10  $\mu$ s / div.



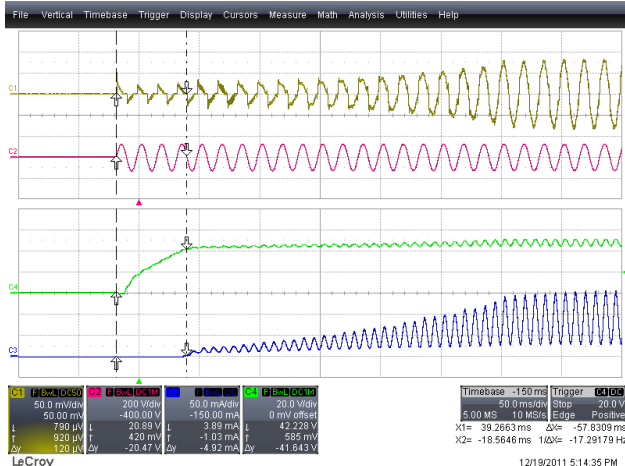
**Figure 20** – 132 VAC / 60 Hz, 48 V LED String.  
 Ch1:  $I_{DRAIN}$ , 0.2 A / div.  
 Ch2:  $V_{DRAIN}$ , 100 V / div.  
 Time Scale: 5 ms / div.



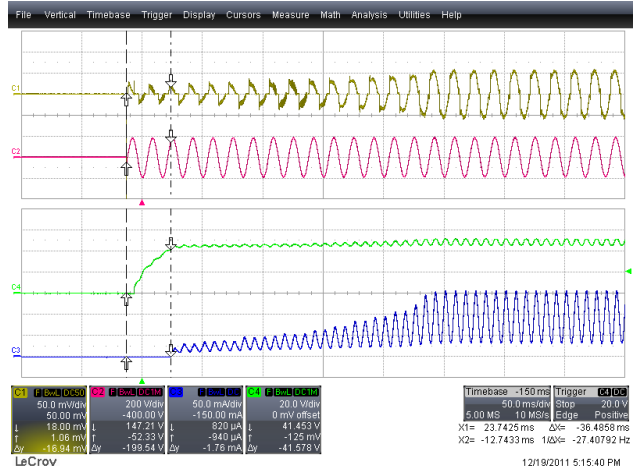
**Figure 21** – 132 VAC / 60 Hz, 48 V LED String.  
 Ch1:  $I_{DRAIN}$ , 0.2 A / div.  
 Ch2:  $V_{DRAIN}$ , 100 V / div.  
 Time Scale: 5 ms / div.  
 Zoom Time Scale: 10 μs / div.



### 10.3 Output Voltage Start-up Profile

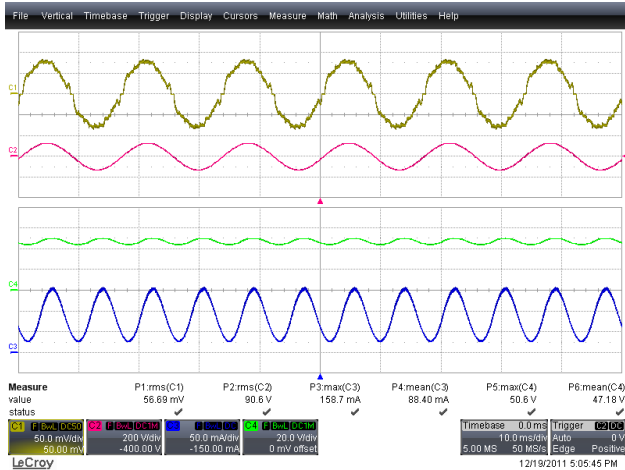


**Figure 22 – 90 VAC / 60 Hz, 48 V LED String.**  
 Ch1:  $I_{IN}$ , 50 mA / div.  
 Ch2:  $V_{IN}$ , 200 V / div.  
 Ch3:  $I_{OUT}$ , 50 mA / div.  
 Ch4:  $V_{OUT}$ , 20 V / div.  
 Time Scale: 50 ms / div.

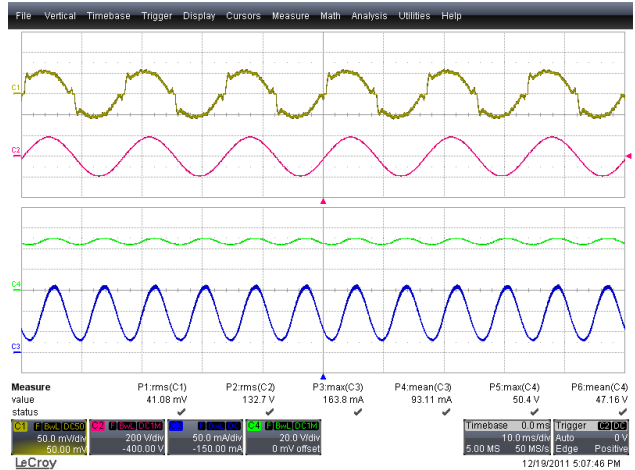


**Figure 23 – 132 VAC / 60 Hz, 48 V LED String.**  
 Ch1:  $I_{IN}$ , 50 mA / div.  
 Ch2:  $V_{IN}$ , 200 V / div.  
 Ch3:  $I_{OUT}$ , 50 mA / div.  
 Ch4:  $V_{OUT}$ , 20 V / div.  
 Time Scale: 50 ms / div.

### 10.4 Input and Output Voltage and Current Profiles

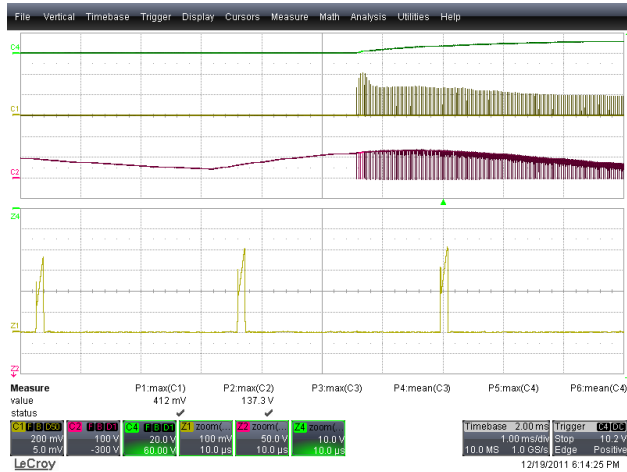


**Figure 24 – 90 VAC / 60 Hz, 48 V LED String.**  
 Ch1:  $I_{IN}$ , 50 mA / div.  
 Ch2:  $V_{IN}$ , 200 V / div.  
 Ch3:  $I_{OUT}$ , 50 mA / div.  
 Ch4:  $V_{OUT}$ , 20 V / div.  
 Time Scale: 10 ms / div.



**Figure 25 – 132 VAC / 60 Hz, 48 V LED String.**  
 Ch1:  $I_{IN}$ , 50 mA / div.  
 Ch2:  $V_{IN}$ , 200 V / div.  
 Ch3:  $I_{OUT}$ , 50 mA / div.  
 Ch4:  $V_{OUT}$ , 20 V / div.  
 Time Scale: 10 ms / div.

### 10.5 Drain Voltage and Current Profile with Output Shorted



**Figure 26** – 90 VAC / 60 Hz, 48 V LED String.

Ch1:  $I_{DRAIN}$ , 0.2 A / div.  
 Ch2:  $V_{DRAIN}$ , 100 V / div.  
 Time Scale: 1 ms / div.

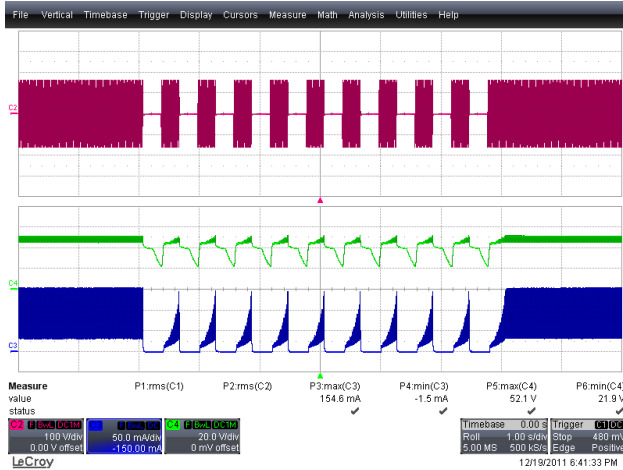


**Figure 27** – 132 VAC / 60 Hz, 48 V LED String.

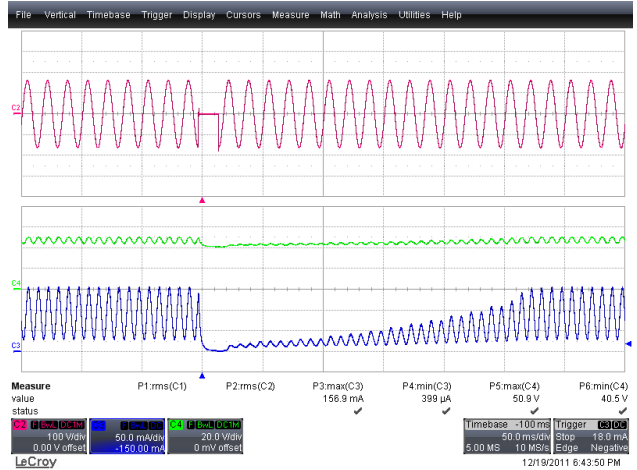
Ch1:  $I_{DRAIN}$ , 0.2 A / div.  
 Ch2:  $V_{DRAIN}$ , 100 V / div.  
 Time Scale: 1 ms / div.  
 Zoom Time Scale: 10 μs / div.



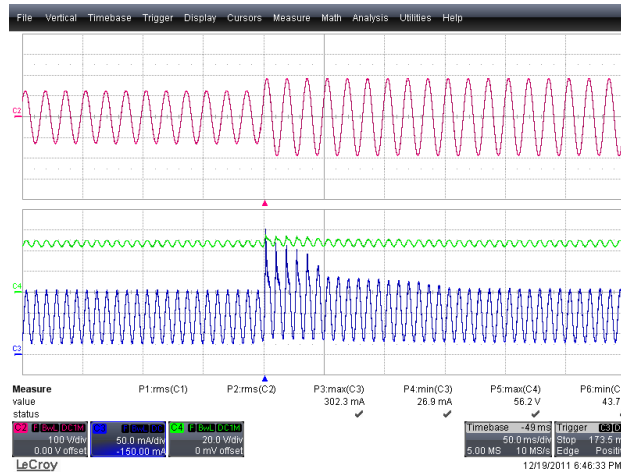
### 10.6 Line Transient Response



**Figure 28** – 115 VAC / 50 Hz, 48 V LED String.  
 300 ms On – 300 ms Off.  
 Ch2:  $V_{IN}$ , 100 V / div.  
 Ch3:  $I_{OUT}$ , 50 mA / div.  
 Ch4:  $V_{OUT}$ , 20 V / div.  
 Time Scale: 1 s / div.



**Figure 29** – 230 VAC / 50 Hz, 48 V LED String.  
 1-Cycle Drop-Out.  
 Ch2:  $V_{IN}$ , 100 V / div.  
 Ch3:  $I_{OUT}$ , 50 mA / div.  
 Ch4:  $V_{OUT}$ , 20 V / div.  
 Time Scale: 50 ms / div.



**Figure 30** – Line Transient from 90 VAC to 132 VAC.  
 Ch2:  $V_{IN}$ , 100 V / div.  
 Ch3:  $I_{OUT}$ , 50 mA / div.  
 Ch4:  $V_{OUT}$ , 20 V / div.  
 Time Scale: 50 ms / div.



### 10.7 Brown-out

Input voltage slew rate of 1 V / s from 90-0-90 VAC / 60 Hz line input variation; no failure observed.

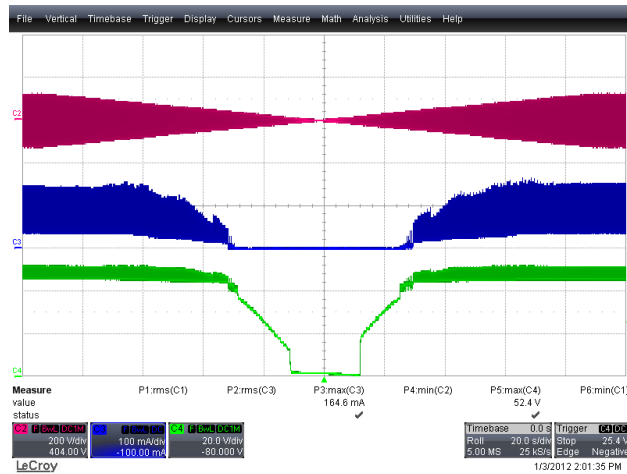


Figure 31 – Brownout, 48 V LED String.

Ch2:  $V_{IN}$ , 200 V / div.  
 Ch3:  $I_{OUT}$ , 100 mA / div.  
 Ch4:  $V_{OUT}$ , 20 V / div.  
 Time Scale: 20 s / div.

### 10.8 Disconnected Load

This LED driver is protected by failure of VR1 in case of no-load condition.

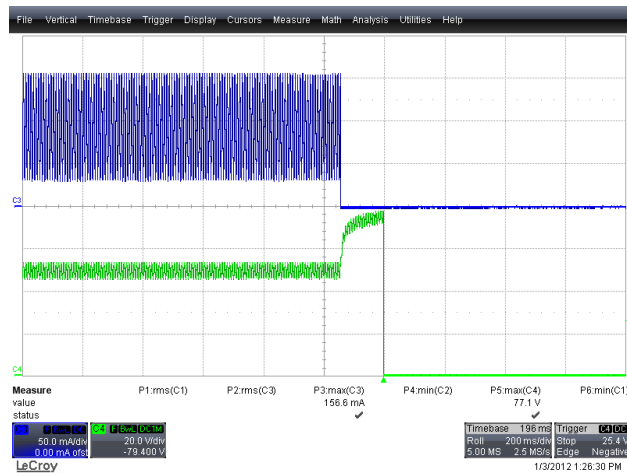
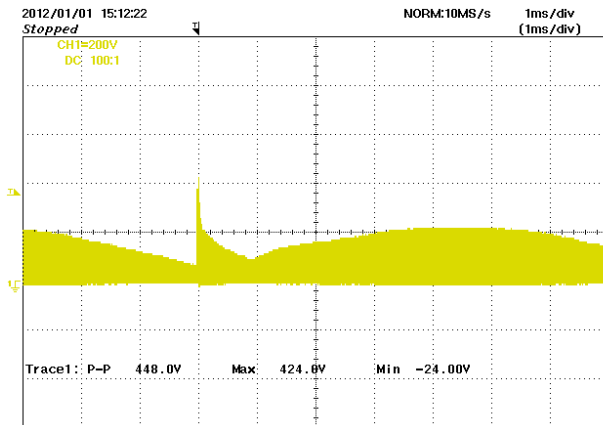


Figure 32 – 115 VAC / 60 Hz, 48 V LED String.

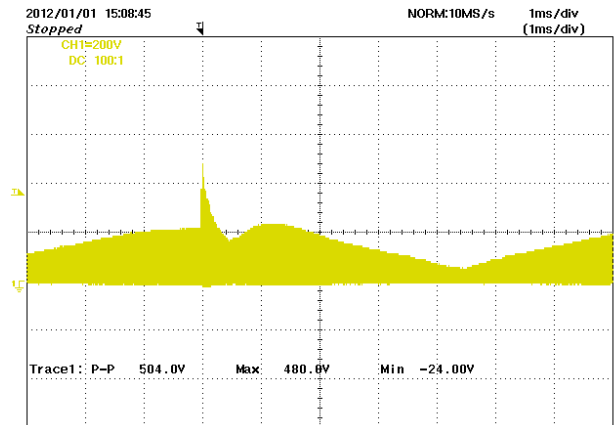
Ch3:  $I_{OUT}$ , 50 mA / div.  
 Ch4:  $V_{OUT}$ , 20 V / div.  
 Time Scale: 0.2 s / div.



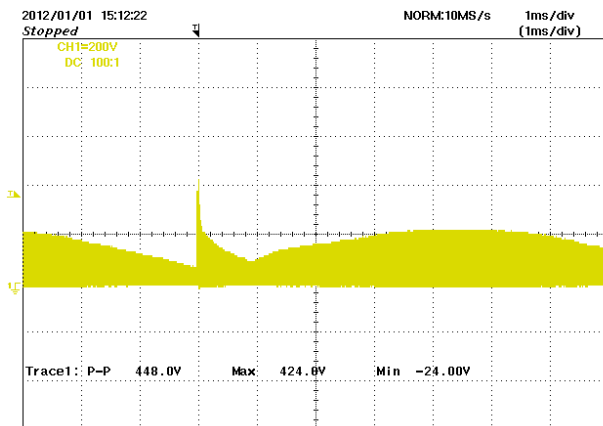
### 10.9 Line Surge Waveform



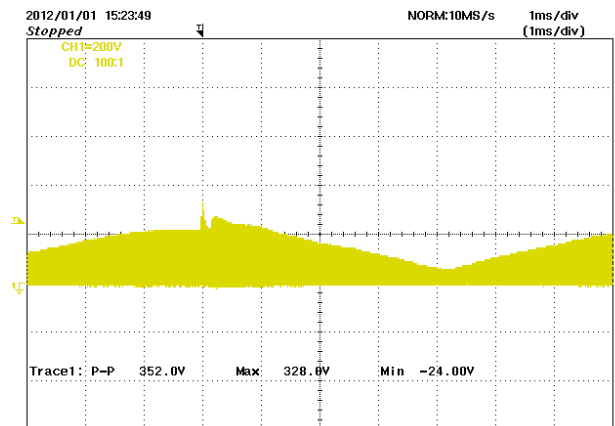
**Figure 33** – 115 VAC / 60 Hz,  
(+)500 V Differential Line Surge at 0°.  
Ch1:  $V_{IN}$ , 200 V / div.  
Time Scale: 1 ms / div.  
 $V_{DS}$ : 424.0  $V_{PK}$



**Figure 34** – 115 VAC / 60 Hz,  
(+)500 V Differential Line Surge at 90°.  
Ch1:  $V_{IN}$ , 200 V / div.  
Time Scale: 1 ms / div.  
 $V_{DS}$ : 480.0  $V_{PK}$

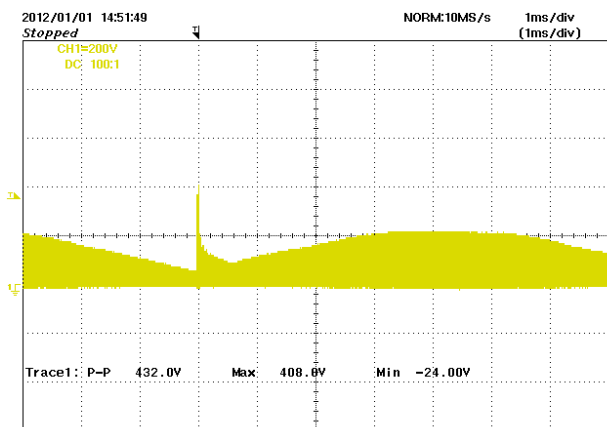


**Figure 35** – 115 VAC / 60 Hz,  
(-)500 V Differential Line Surge at 0°.  
Ch1:  $V_{IN}$ , 200 V / div.  
Time Scale: 1 ms / div.  
 $V_{DS}$ : 424.0  $V_{PK}$ .

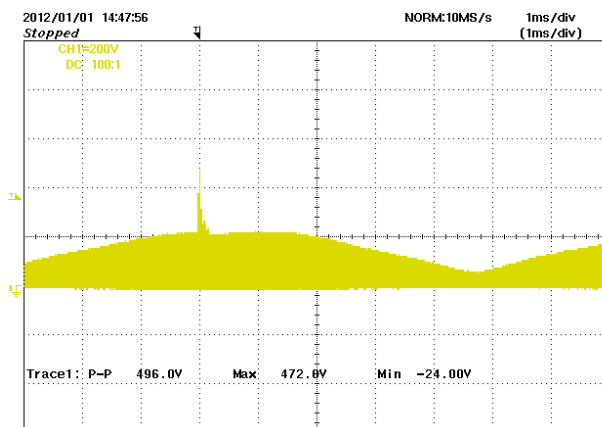


**Figure 36** – 115 VAC / 60 Hz,  
(-)500 V Differential Line Surge at 90°.  
Ch1:  $V_{IN}$ , 200 V / div.  
Time Scale: 1 ms / div.  
 $V_{DS}$ : 328.0  $V_{PK}$ .

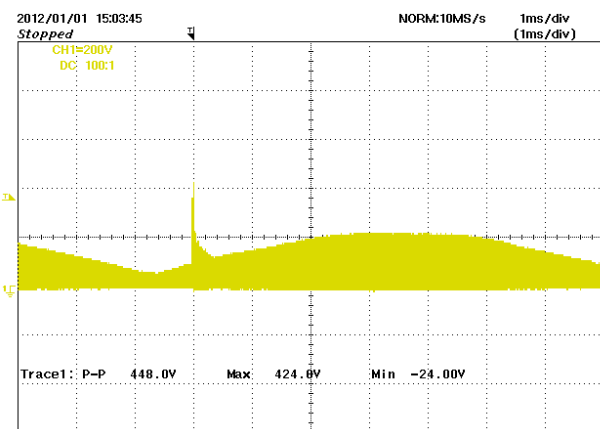




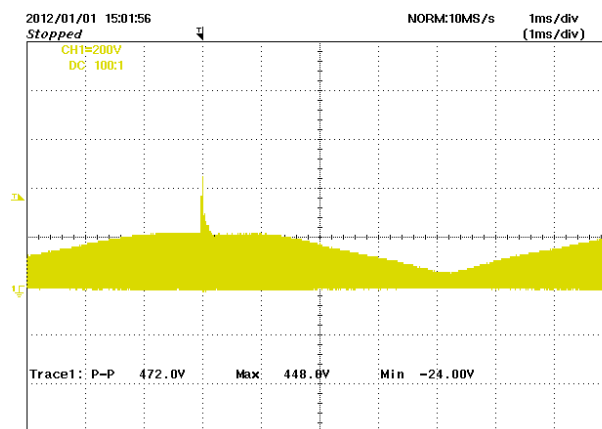
**Figure 37** – 115 VAC / 60 Hz,  
 (+)2.5 kV Differential Ring Surge at 0°.   
 Ch1:  $V_{IN}$ , 200 V / div.   
 Time Scale: 1 m / div.   
 $V_{DS}$ : 408.0  $V_{PK}$ .



**Figure 38** – 115 VAC / 60 Hz,  
 (+)2.5 kV Differential Ring Surge at 90°.   
 Ch1:  $V_{IN}$ , 200 V / div.   
 Time Scale: 1 ms / div.   
 $V_{DS}$ : 472.0  $V_{PK}$ .



**Figure 39** – 115 VAC / 60 Hz,  
 (-)2.5 kV Differential Ring Surge at 0°.   
 Ch1:  $V_{IN}$ , 200 V / div.   
 Time Scale: 1 ms / div.   
 $V_{DS}$ : 424.0  $V_{PK}$ .



**Figure 40** – 230 VAC / 60 Hz,  
 (-)2.5 kV Differential Ring Surge at 90°.   
 Ch2:  $V_{IN}$ , 500 V / div.   
 Ch4:  $V_{DS}$ , 200 V / div.   
 Time Scale: 20  $\mu$ s / div.   
 $V_{DS}$ : 448.0  $V_{PK}$ .





## 11 Dimming Performance

### 11.1 Compatibility Table

The LED driver was verified to the following list of 120 V dimmers. This table does not limit the types and models of dimmers to be matched in the LED driver but represents a limited cross section of the dimmers available in the market. Some dimmers require multiple LED drivers in order to maintain the holding current of the TRIAC and avoid shimmer or flicker.

Brand	Model	Power	Units Required	I <sub>OUT</sub> Maximum (mA)	I <sub>OUT</sub> Minimum (mA)	Maximum Phase Angle (°)	Minimum Phase Angle (°)	Comments
LUTRON	TGLV-600-PR-WH	600	1	80	10	138	42	
LUTRON	S-600-PR-WH	600	5	80	5	131	25	Occasional shimmer at very low conduction angle with less than 5 units. TRIAC used has some imbalance
LUTRON	S-600	600	1	89	5	153	35	
LUTRON	S-600P	600	3	81	7	132	35	Occasional shimmer at very low conduction angle with less than 3 units
LUTRON	MAELV-600	600	1	93	12	136	42	
LUTRON	MAW-600	600	5	79	5	136	42	TRIAC does not properly turn-off (shown on graph) and requires at least 5 units to avoid shimmer/flicker
LUTRON	MIR-600	600	5	66	7	136	42	TRIAC does not properly turn-off (shown on graph) and requires at least 5 units to avoid shimmer/flicker
COOPER	S106P	600	4	89	7	140	40	Occasional shimmer at very low conduction angle with less than 4 units
LEVITON	6615-POW	600	1	93	27	146	50	



### 11.2 NEMA Compliance

The graph below shows the dimming performance of the unit as a function of TRIAC firing angle. The limit represents the NEMA requirements (note: it is assumed that the light intensity (lumen) is proportional to the output current and thus the graph shows the current instead of light intensity).

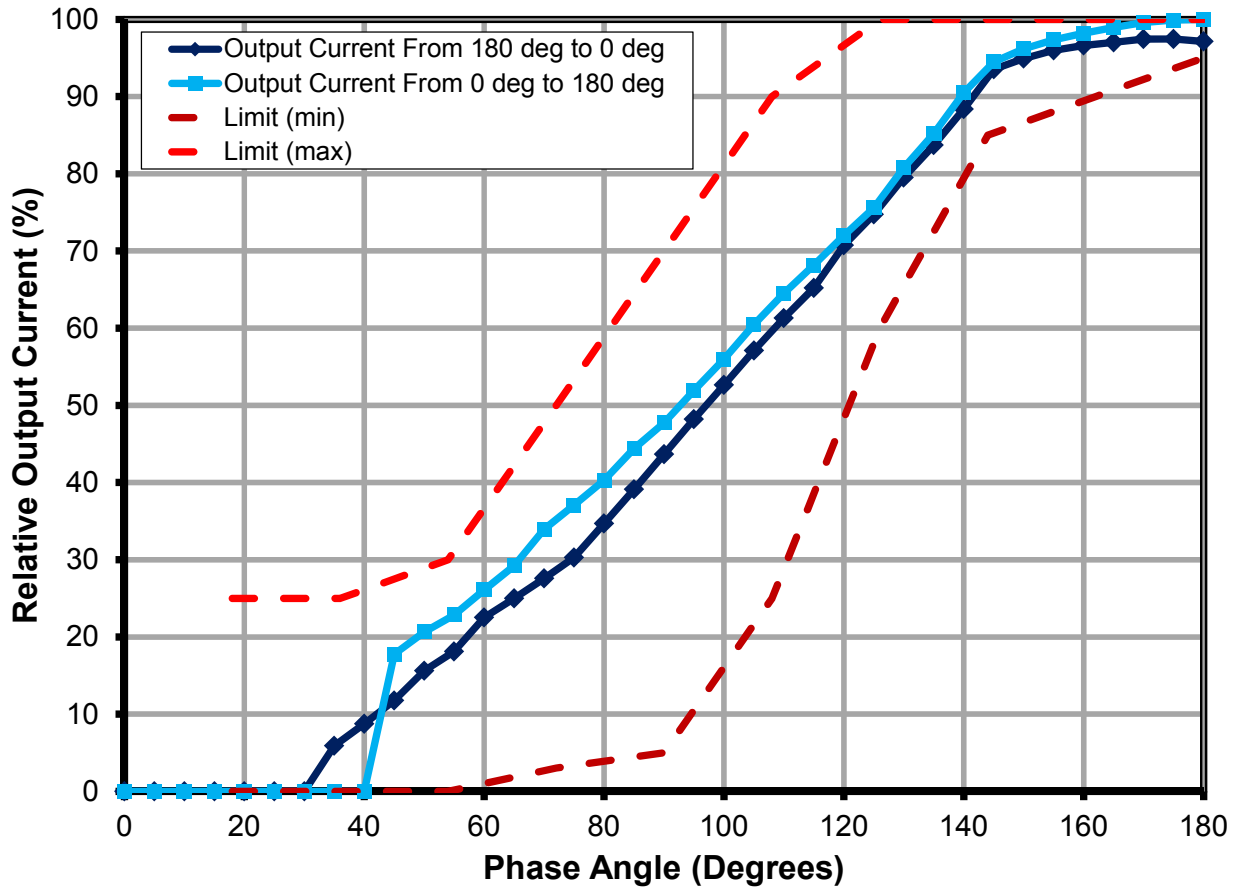
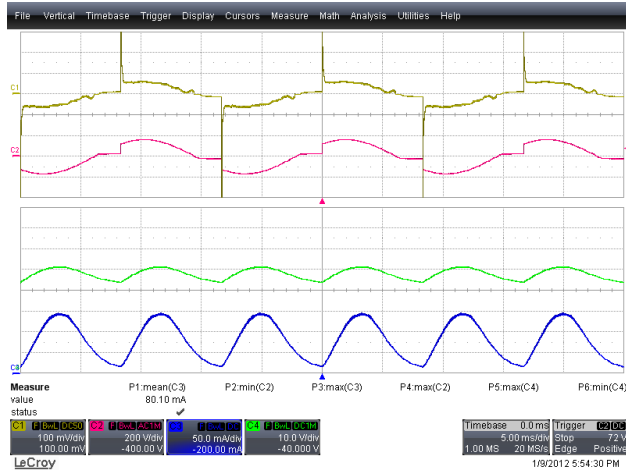


Figure 41 – Dimming Characteristics with Ideal TRIAC Simulation.



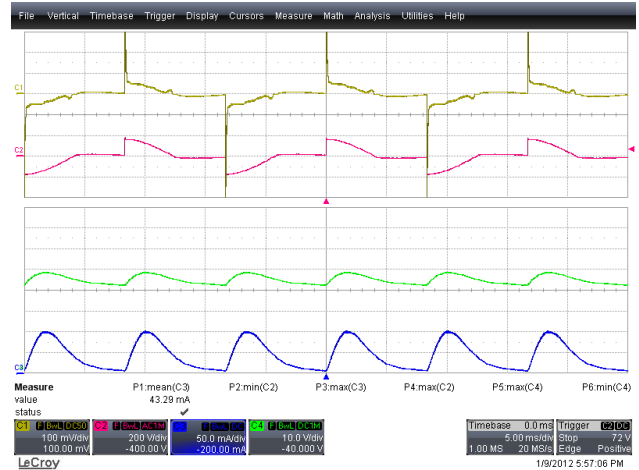
## 12 Dimming Waveforms

### 12.1 Lutron TGLV-600PR Dimmer



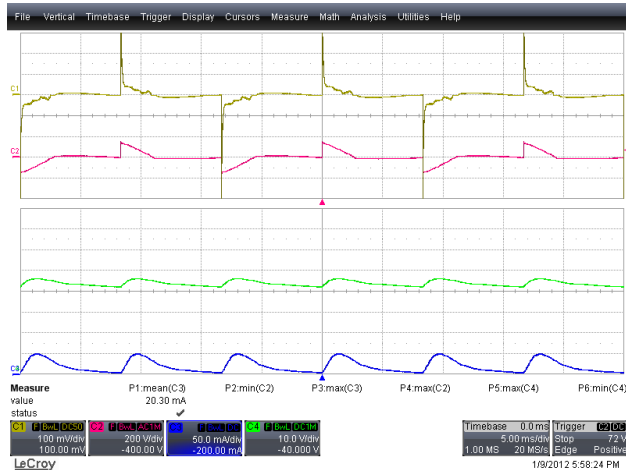
**Figure 42 – Full Conduction.**

Ch1:  $I_{IN}$ , 100 mA / div.  
 Ch2:  $V_{IN}$ , 200 V / div.  
 Ch3:  $I_{OUT}$ , 50 mA / div.  
 Ch4:  $V_{OUT}$ , 10 V / div.  
 Time Scale: 5 ms / div.



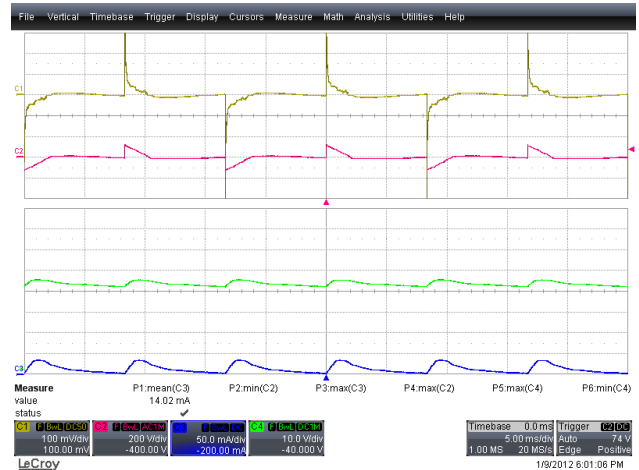
**Figure 43 – 90 Degrees.**

Ch1:  $I_{IN}$ , 100 mA / div.  
 Ch2:  $V_{IN}$ , 200 V / div.  
 Ch3:  $I_{OUT}$ , 50 mA / div.  
 Ch4:  $V_{OUT}$ , 10 V / div.  
 Time Scale: 5 ms / div.



**Figure 44 – 60 Degrees.**

Ch1:  $I_{IN}$ , 100 mA / div.  
 Ch2:  $V_{IN}$ , 200 V / div.  
 Ch3:  $I_{OUT}$ , 50 mA / div.  
 Ch4:  $V_{OUT}$ , 10 V / div.  
 Time Scale: 5 ms / div.

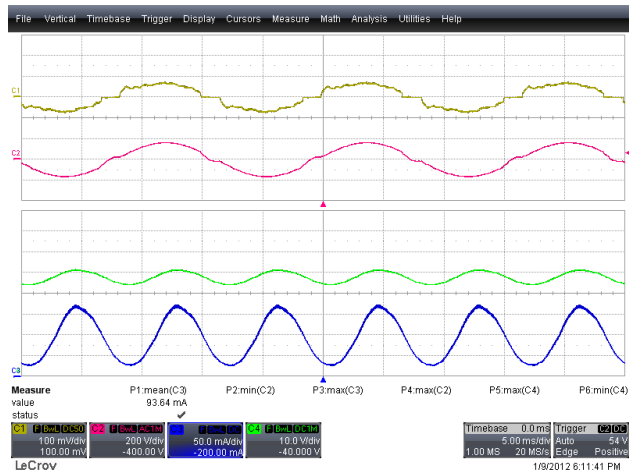


**Figure 45 – 45 Degrees.**

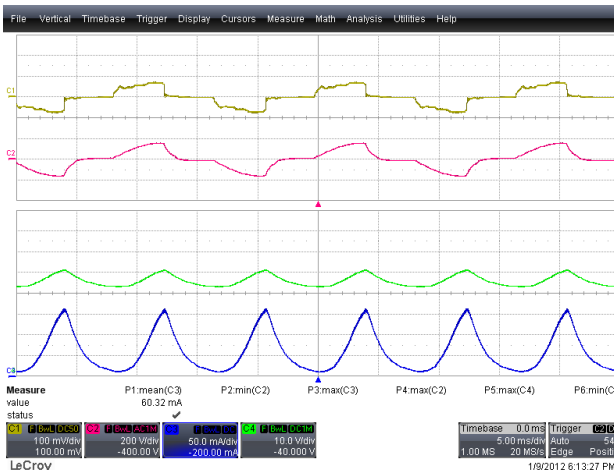
Ch1:  $I_{IN}$ , 100 mA / div.  
 Ch2:  $V_{IN}$ , 200 V / div.  
 Ch3:  $I_{OUT}$ , 50 mA / div.  
 Ch4:  $V_{OUT}$ , 10 V / div.  
 Time Scale: 5 ms / div.



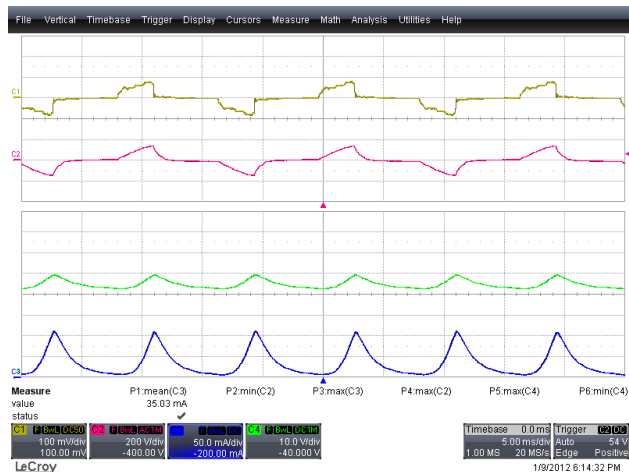
### 12.2 Leviton 6615-POW Dimmer



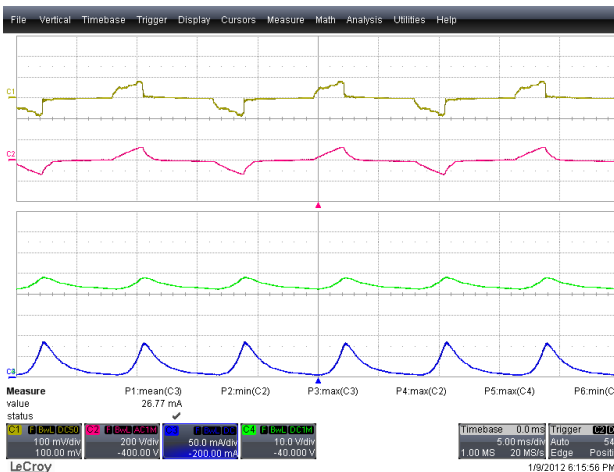
**Figure 46 – Full Conduction.**  
 Ch1:  $I_{IN}$ , 100 mA / div.  
 Ch2:  $V_{IN}$ , 200 V / div.  
 Ch3:  $I_{OUT}$ , 50 mA / div.  
 Ch4:  $V_{OUT}$ , 10 V / div.  
 Time Scale: 5 ms / div.



**Figure 47 – 90 Degrees.**  
 Ch1:  $I_{IN}$ , 100 mA / div.  
 Ch2:  $V_{IN}$ , 200 V / div.  
 Ch3:  $I_{OUT}$ , 50 mA / div.  
 Ch4:  $V_{OUT}$ , 10 V / div.  
 Time Scale: 5 ms / div.



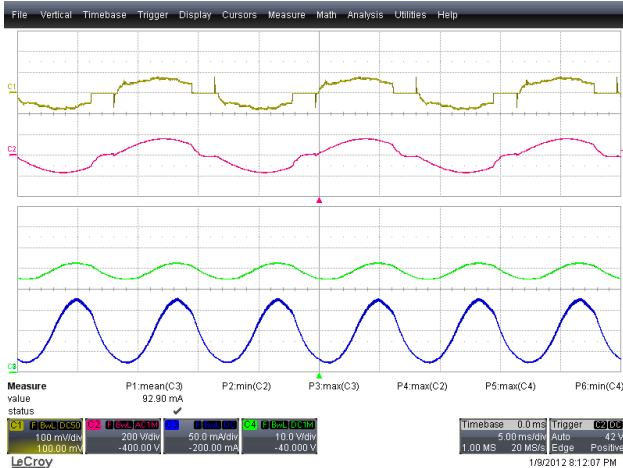
**Figure 48 – 60 Degrees.**  
 Ch1:  $I_{IN}$ , 100 mA / div.  
 Ch2:  $V_{IN}$ , 200 V / div.  
 Ch3:  $I_{OUT}$ , 50 mA / div.  
 Ch4:  $V_{OUT}$ , 10 V / div.  
 Time Scale: 5 ms / div.



**Figure 49 – 50 Degrees, Full Dimming.**  
 Ch1:  $I_{IN}$ , 100 mA / div.  
 Ch2:  $V_{IN}$ , 200 V / div.  
 Ch3:  $I_{OUT}$ , 50 mA / div.  
 Ch4:  $V_{OUT}$ , 10 V / div.  
 Time Scale: 5 ms / div.

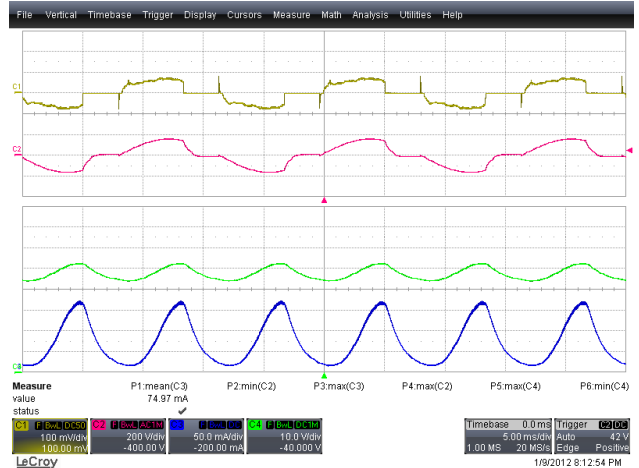


### 12.3 Lutron MAELV-600 Dimmer



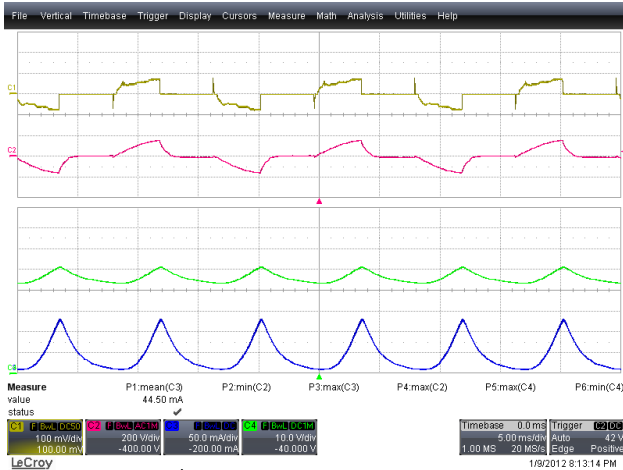
**Figure 50 – Full Conduction.**

Ch1:  $I_{IN}$ , 100 mA / div.  
 Ch2:  $V_{IN}$ , 200 V / div.  
 Ch3:  $I_{OUT}$ , 50 mA / div.  
 Ch4:  $V_{OUT}$ , 10 V / div.  
 Time Scale: 5 ms / div.



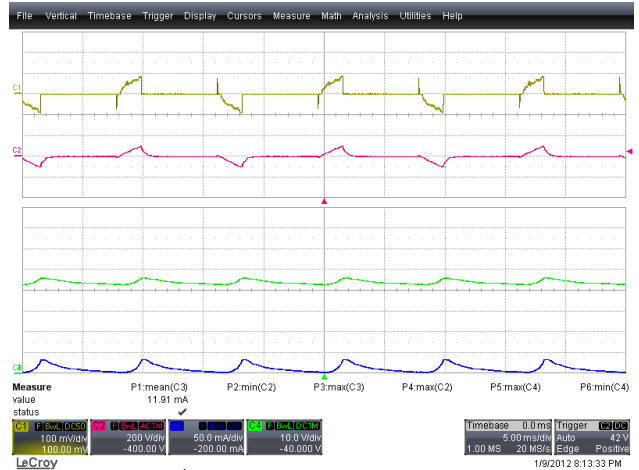
**Figure 51 – 5<sup>th</sup> Setting.**

Ch1:  $I_{IN}$ , 100 mA / div.  
 Ch2:  $V_{IN}$ , 200 V / div.  
 Ch3:  $I_{OUT}$ , 50 mA / div.  
 Ch4:  $V_{OUT}$ , 10 V / div.  
 Time Scale: 5 ms / div.



**Figure 52 – 3<sup>rd</sup> Setting.**

Ch1:  $I_{IN}$ , 100 mA / div.  
 Ch2:  $V_{IN}$ , 200 V / div.  
 Ch3:  $I_{OUT}$ , 50 mA / div.  
 Ch4:  $V_{OUT}$ , 10 V / div.  
 Time Scale: 5 ms / div.

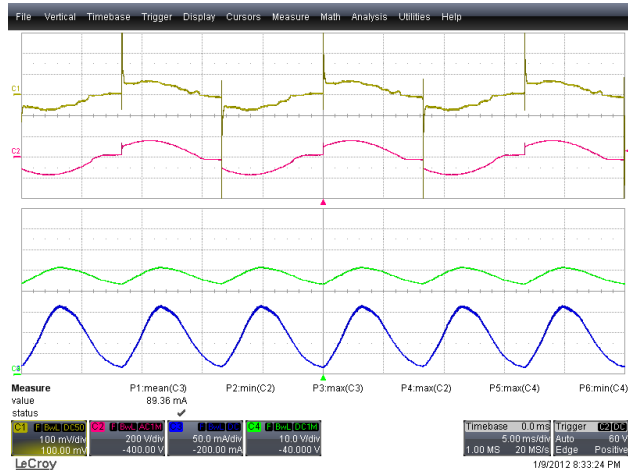


**Figure 53 – 1<sup>st</sup> Setting.**

Ch1:  $I_{IN}$ , 100 mA / div.  
 Ch2:  $V_{IN}$ , 200 V / div.  
 Ch3:  $I_{OUT}$ , 50 mA / div.  
 Ch4:  $V_{OUT}$ , 10 V / div.  
 Time Scale: 5 ms / div.

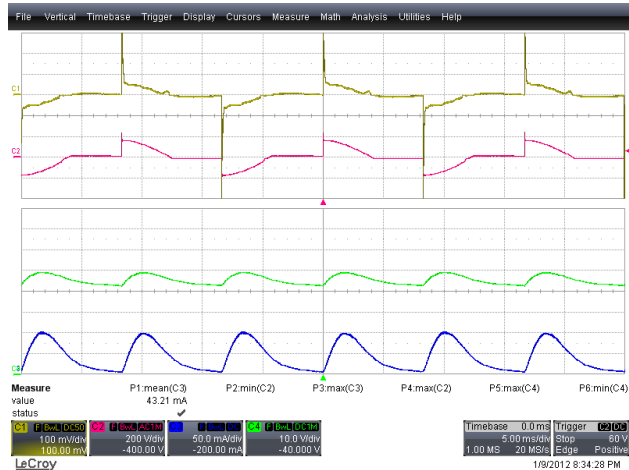


### 12.4 Lutron S-600 Dimmer



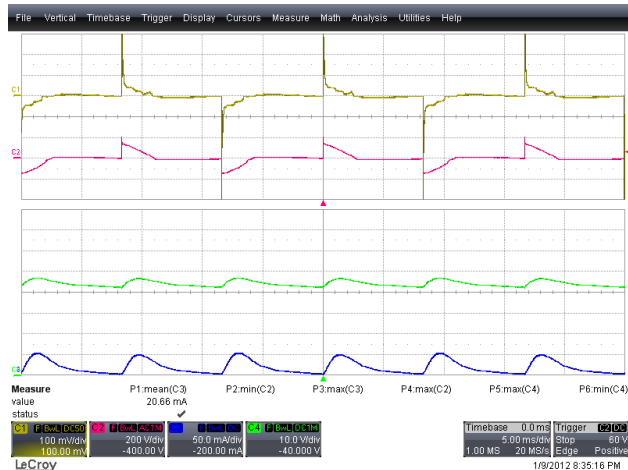
**Figure 54 – Full Conduction.**

Ch1:  $I_{IN}$ , 100 mA / div.  
 Ch2:  $V_{IN}$ , 200 V / div.  
 Ch3:  $I_{OUT}$ , 50 mA / div.  
 Ch4:  $V_{OUT}$ , 10 V / div.  
 Time Scale: 5 ms / div.



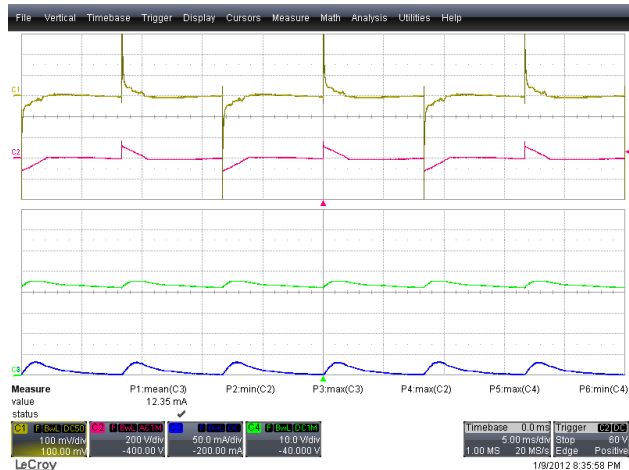
**Figure 55 – 90 Degrees.**

Ch1:  $I_{IN}$ , 100 mA / div.  
 Ch2:  $V_{IN}$ , 200 V / div.  
 Ch3:  $I_{OUT}$ , 50 mA / div.  
 Ch4:  $V_{OUT}$ , 10 V / div.  
 Time Scale: 5 ms / div.



**Figure 56 – 60 Degrees.**

Ch1:  $I_{IN}$ , 100 mA / div.  
 Ch2:  $V_{IN}$ , 200 V / div.  
 Ch3:  $I_{OUT}$ , 50 mA / div.  
 Ch4:  $V_{OUT}$ , 10 V / div.  
 Time Scale: 5 ms / div.

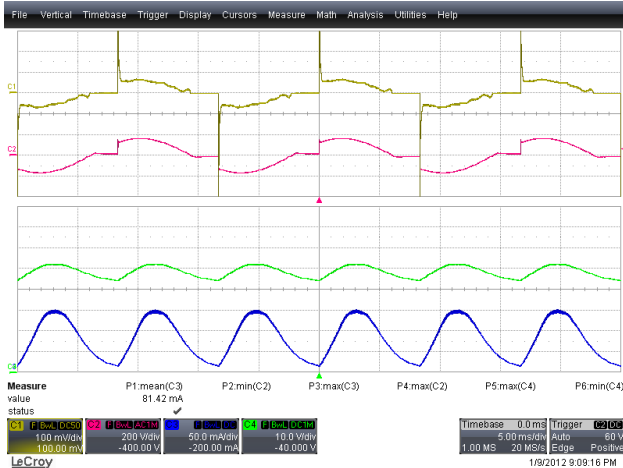


**Figure 57 – 45 Degrees.**

Ch1:  $I_{IN}$ , 100 mA / div.  
 Ch2:  $V_{IN}$ , 200 V / div.  
 Ch3:  $I_{OUT}$ , 50 mA / div.  
 Ch4:  $V_{OUT}$ , 10 V / div.  
 Time Scale: 5 ms / div.

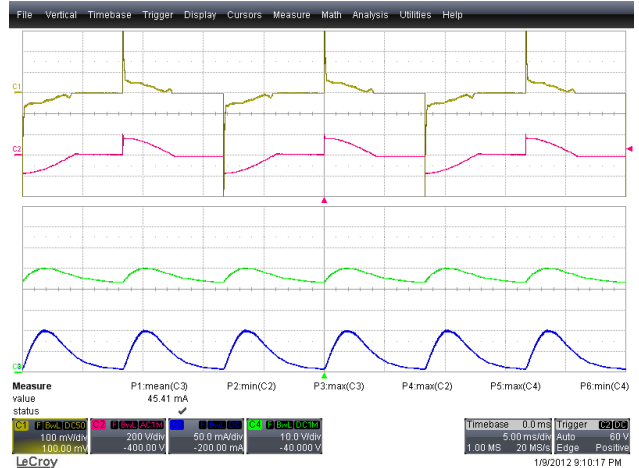


### 12.5 Lutron S-600P Dimmer



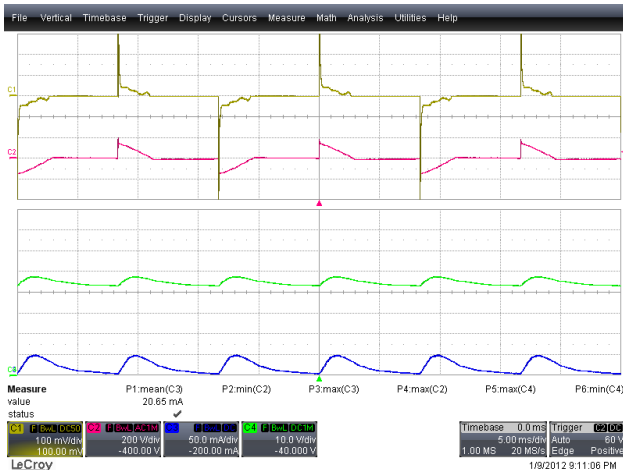
**Figure 58 – Full Conduction.**

Ch1:  $I_{IN}$ , 100 mA / div.  
 Ch2:  $V_{IN}$ , 200 V / div.  
 Ch3:  $I_{OUT}$ , 50 mA / div.  
 Ch4:  $V_{OUT}$ , 10 V / div.  
 Time Scale: 5 ms / div.



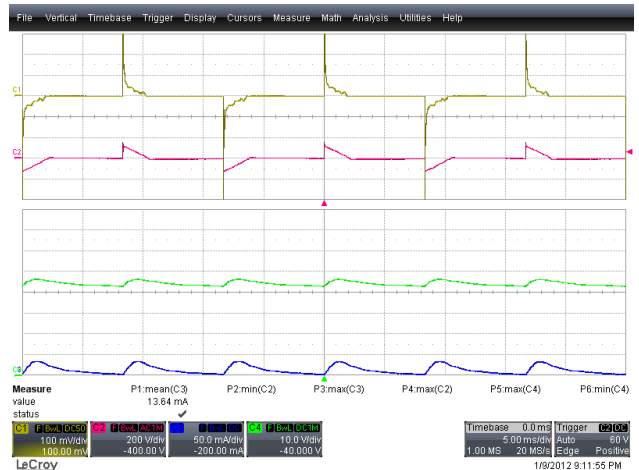
**Figure 59 – 90 Degrees.**

Ch1:  $I_{IN}$ , 100 mA / div.  
 Ch2:  $V_{IN}$ , 200 V / div.  
 Ch3:  $I_{OUT}$ , 50 mA / div.  
 Ch4:  $V_{OUT}$ , 10 V / div.  
 Time Scale: 5 ms / div.



**Figure 60 – 60 Degrees.**

Ch1:  $I_{IN}$ , 100 mA / div.  
 Ch2:  $V_{IN}$ , 200 V / div.  
 Ch3:  $I_{OUT}$ , 50 mA / div.  
 Ch4:  $V_{OUT}$ , 10 V / div.  
 Time Scale: 5 ms / div.

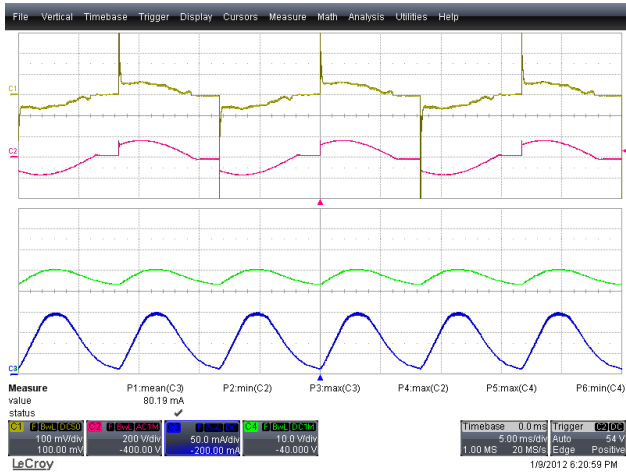


**Figure 61 – 45 Degrees.**

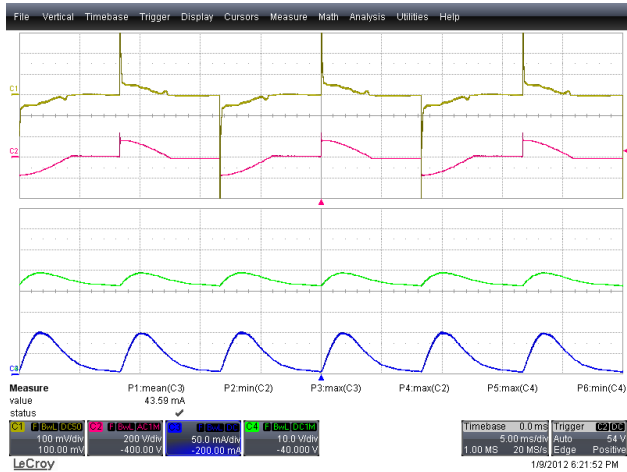
Ch1:  $I_{IN}$ , 100 mA / div.  
 Ch2:  $V_{IN}$ , 200 V / div.  
 Ch3:  $I_{OUT}$ , 50 mA / div.  
 Ch4:  $V_{OUT}$ , 10 V / div.  
 Time Scale: 5 ms / div.



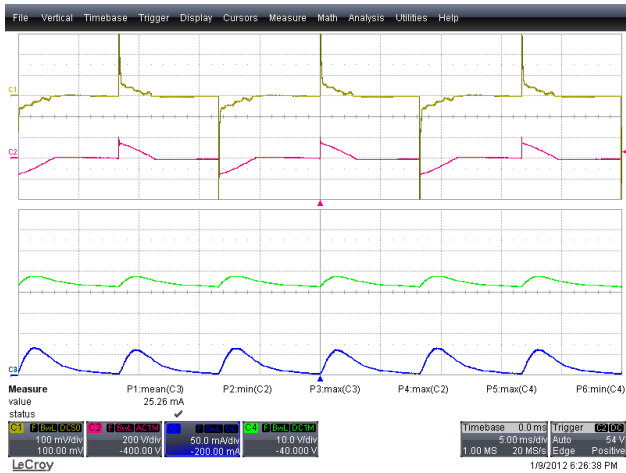
### 12.6 Lutron Skylark S-600-PR Dimmer



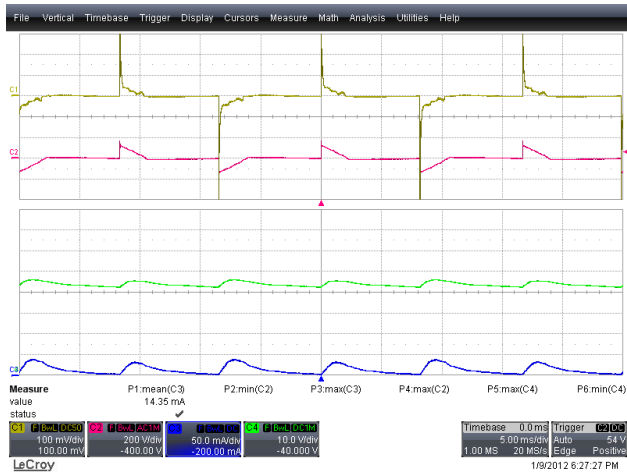
**Figure 62 – Full Conduction.**  
 Ch1: I<sub>IN</sub>, 100 mA / div.  
 Ch2: V<sub>IN</sub>, 200 V / div.  
 Ch3: I<sub>OUT</sub>, 50 mA / div.  
 Ch4: V<sub>OUT</sub>, 10 V / div.  
 Time Scale: 5 ms / div.



**Figure 63 – 90 Degrees.**  
 Ch1: I<sub>IN</sub>, 100 mA / div.  
 Ch2: V<sub>IN</sub>, 200 V / div.  
 Ch3: I<sub>OUT</sub>, 50 mA / div.  
 Ch4: V<sub>OUT</sub>, 10 V / div.  
 Time Scale: 5 ms / div.



**Figure 64 – 60 Degrees.**  
 Ch1: I<sub>IN</sub>, 100 mA / div.  
 Ch2: V<sub>IN</sub>, 200 V / div.  
 Ch3: I<sub>OUT</sub>, 50 mA / div.  
 Ch4: V<sub>OUT</sub>, 10 V / div.  
 Time Scale: 5 ms / div.

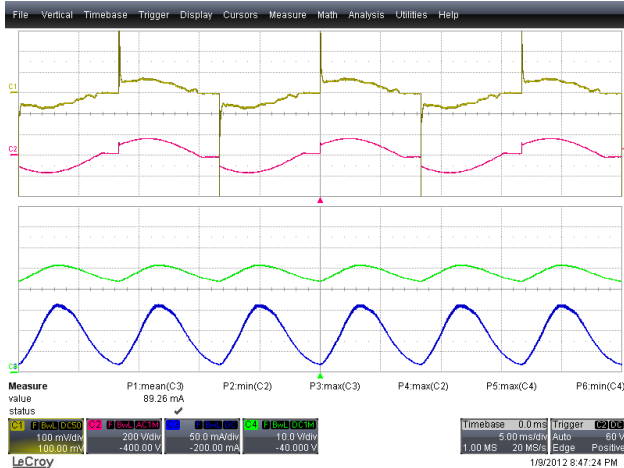


**Figure 65 – 45 Degrees.**  
 Ch1: I<sub>IN</sub>, 100 mA / div.  
 Ch2: V<sub>IN</sub>, 200 V / div.  
 Ch3: I<sub>OUT</sub>, 50 mA / div.  
 Ch4: V<sub>OUT</sub>, 10 V / div.  
 Time Scale: 5 ms / div.

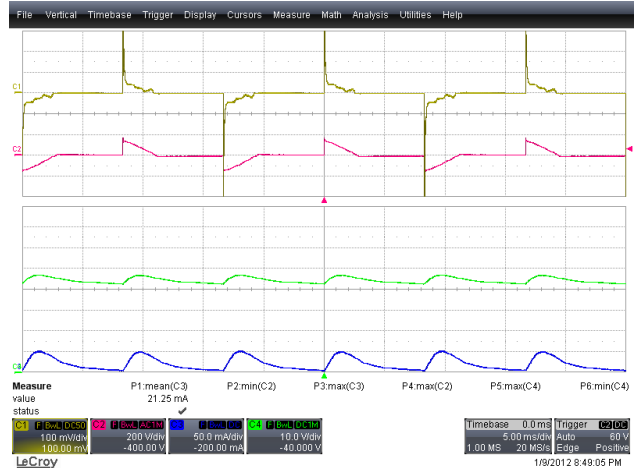




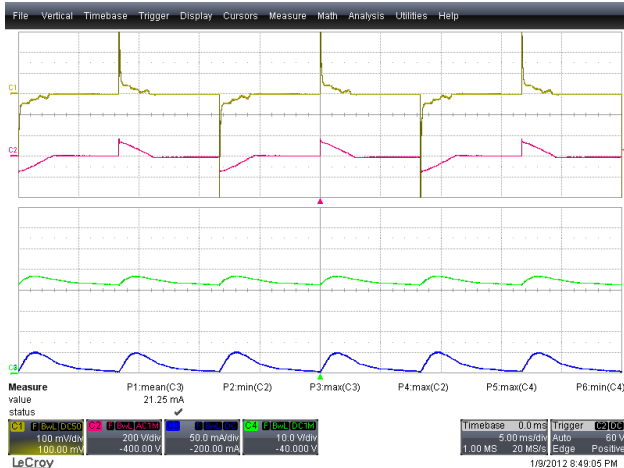
### 12.7 Cooper S106P Dimmer



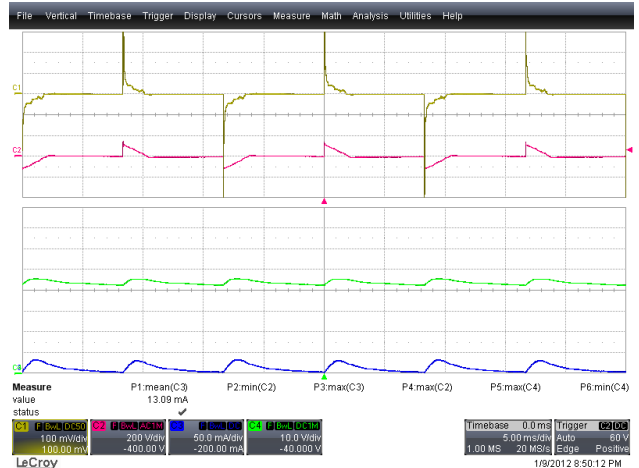
**Figure 66 – Full Conduction.**  
 Ch1:  $I_{IN}$ , 100 mA / div.  
 Ch2:  $V_{IN}$ , 200 V / div.  
 Ch3:  $I_{OUT}$ , 50 mA / div.  
 Ch4:  $V_{OUT}$ , 10 V / div.  
 Time Scale: 5 ms / div.



**Figure 67 – 90 Degrees.**  
 Ch1:  $I_{IN}$ , 100 mA / div.  
 Ch2:  $V_{IN}$ , 200 V / div.  
 Ch3:  $I_{OUT}$ , 50 mA / div.  
 Ch4:  $V_{OUT}$ , 10 V / div.  
 Time Scale: 5 ms / div.

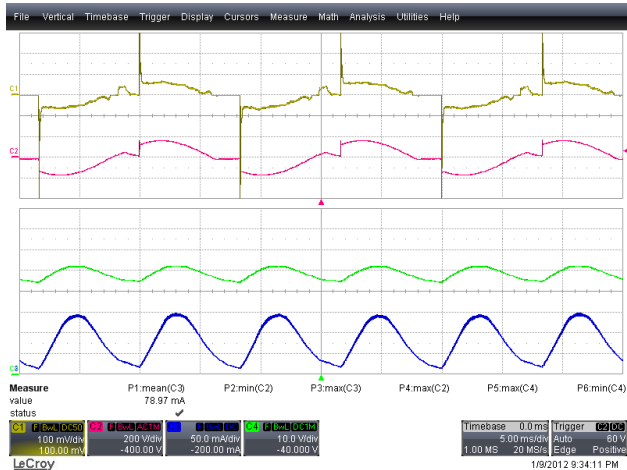


**Figure 68 – 60 Degrees.**  
 Ch1:  $I_{IN}$ , 100 mA / div.  
 Ch2:  $V_{IN}$ , 200 V / div.  
 Ch3:  $I_{OUT}$ , 50 mA / div.  
 Ch4:  $V_{OUT}$ , 10 V / div.  
 Time Scale: 5 ms / div.



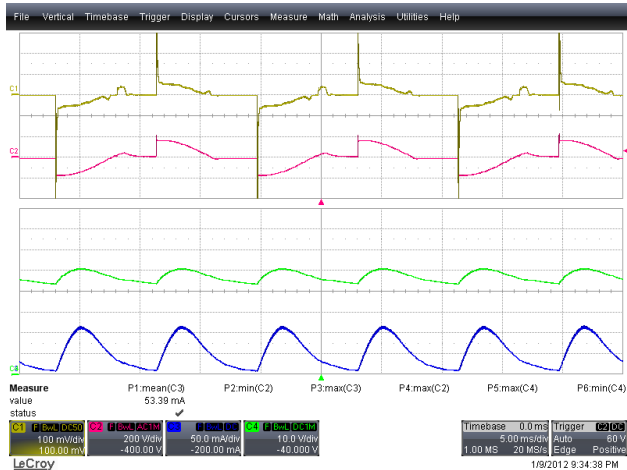
**Figure 69 – 45 Degrees.**  
 Ch1:  $I_{IN}$ , 100 mA / div.  
 Ch2:  $V_{IN}$ , 200 V / div.  
 Ch3:  $I_{OUT}$ , 50 mA / div.  
 Ch4:  $V_{OUT}$ , 10 V / div.  
 Time Scale: 5 ms / div.

### 12.8 Lutron MAW-600 Dimmer



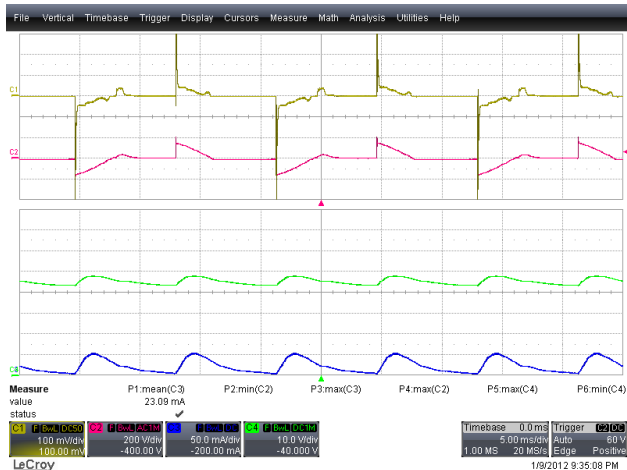
**Figure 70 – Full Conduction.**

Ch1:  $I_{IN}$ , 100 mA / div.  
 Ch2:  $V_{IN}$ , 200 V / div.  
 Ch3:  $I_{OUT}$ , 50 mA / div.  
 Ch4:  $V_{OUT}$ , 10 V / div.  
 Time Scale: 5 ms / div.



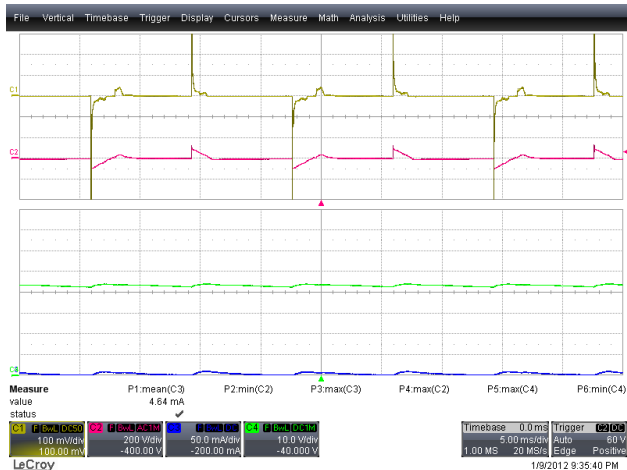
**Figure 71 – 5<sup>th</sup> Setting.**

Ch1:  $I_{IN}$ , 100 mA / div.  
 Ch2:  $V_{IN}$ , 200 V / div.  
 Ch3:  $I_{OUT}$ , 50 mA / div.  
 Ch4:  $V_{OUT}$ , 10 V / div.  
 Time Scale: 5 ms / div.



**Figure 72 – 3<sup>rd</sup> Setting.**

Ch1:  $I_{IN}$ , 100 mA / div.  
 Ch2:  $V_{IN}$ , 200 V / div.  
 Ch3:  $I_{OUT}$ , 50 mA / div.  
 Ch4:  $V_{OUT}$ , 10 V / div.  
 Time Scale: 5 ms / div.

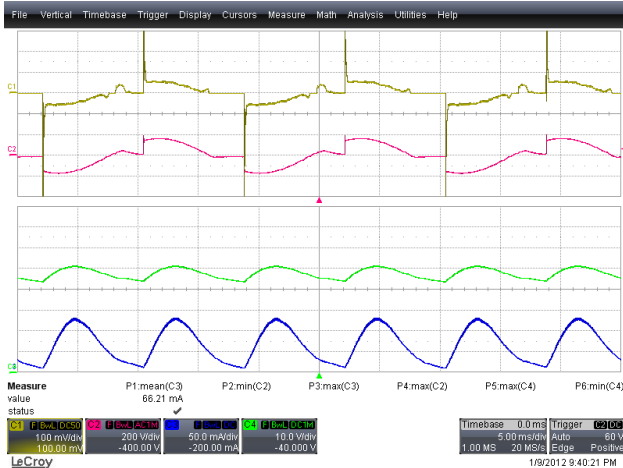


**Figure 73 – 1<sup>st</sup> Setting.**

Ch1:  $I_{IN}$ , 100 mA / div.  
 Ch2:  $V_{IN}$ , 200 V / div.  
 Ch3:  $I_{OUT}$ , 50 mA / div.  
 Ch4:  $V_{OUT}$ , 10 V / div.  
 Time Scale: 5 ms / div.

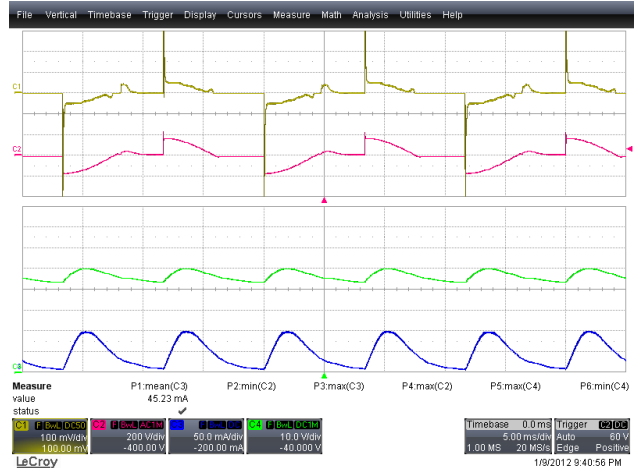


### 12.9 Lutron MIR-600 Dimmer



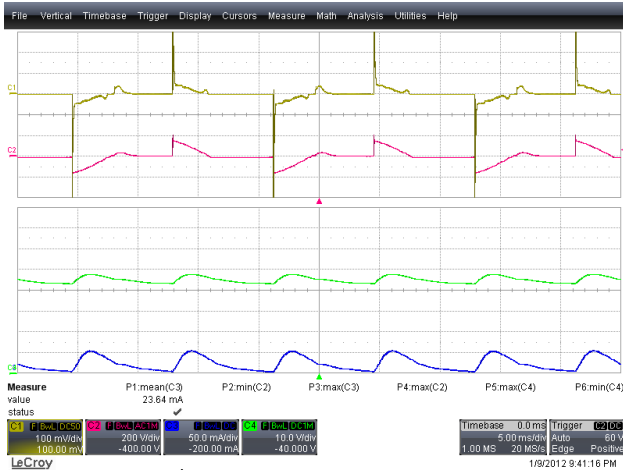
**Figure 74 – Full Conduction.**

Ch1:  $I_{IN}$ , 100 mA / div.  
 Ch2:  $V_{IN}$ , 200 V / div.  
 Ch3:  $I_{OUT}$ , 50 mA / div.  
 Ch4:  $V_{OUT}$ , 10 V / div.  
 Time Scale: 5 ms / div.



**Figure 75 – 5<sup>th</sup> Setting.**

Ch1:  $I_{IN}$ , 100 mA / div.  
 Ch2:  $V_{IN}$ , 200 V / div.  
 Ch3:  $I_{OUT}$ , 50 mA / div.  
 Ch4:  $V_{OUT}$ , 10 V / div.  
 Time Scale: 5 ms / div.



**Figure 76 – 3<sup>rd</sup> Setting.**

Ch1:  $I_{IN}$ , 100 mA / div.  
 Ch2:  $V_{IN}$ , 200 V / div.  
 Ch3:  $I_{OUT}$ , 50 mA / div.  
 Ch4:  $V_{OUT}$ , 10 V / div.  
 Time Scale: 5 ms / div.



**Figure 77 – 1<sup>st</sup> Setting.**

Ch1:  $I_{IN}$ , 100 mA / div.  
 Ch2:  $V_{IN}$ , 200 V / div.  
 Ch3:  $I_{OUT}$ , 50 mA / div.  
 Ch4:  $V_{OUT}$ , 10 V / div.  
 Time Scale: 5 ms / div.



### 13 Line Surge

Input voltage was set at 115 VAC / 60 Hz. Output was loaded with 48 V LED string and operation was verified following each surge event.

Differential input line 1.2 / 50  $\mu$ s surge testing was completed on one test unit to IEC61000-4-5.

Surge Level (V)	Input Voltage (VAC)	Injection Location	Injection Phase (°)	Test Result (Pass/Fail)
+500	115	L to N	0	Pass
-500	115	L to N	0	Pass
+500	115	L to N	90	Pass
-500	115	L to N	90	Pass

Differential input line ring surge testing was completed on one test unit to IEC61000-4-5.

Surge Level (V)	Input Voltage (VAC)	Injection Location	Injection Phase (°)	Test Result (Pass/Fail)
+2500	115	L to N	0	Pass
-2500	115	L to N	0	Pass
+2500	115	L to N	90	Pass
-2500	115	L to N	90	Pass

Unit passes under all test conditions.



## 14 Conducted EMI

### 14.1 Equipment

Receiver:

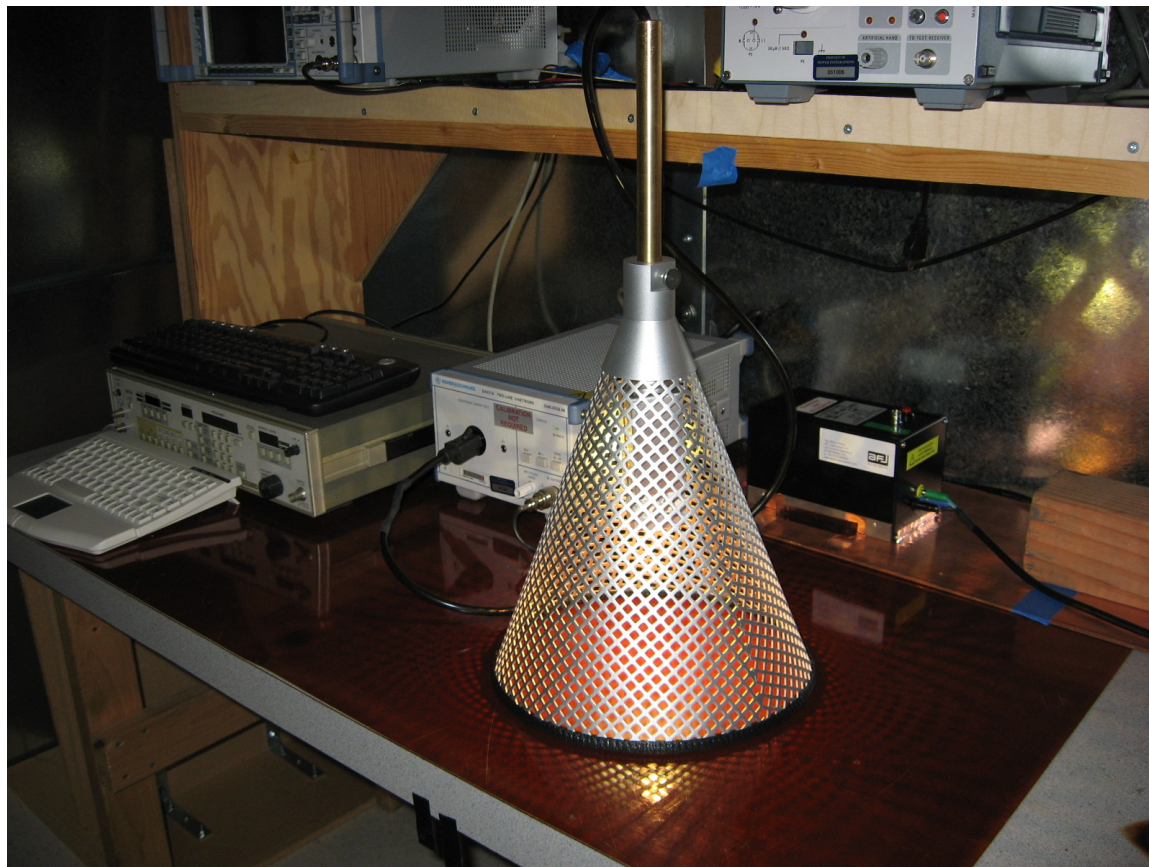
Rohde & Schwartz  
ESPI - Test Receiver (9 kHz – 3 GHz)  
Model No: ESPI3

LISN:

Rohde & Schwartz  
Two-Line-V-Network  
Model No: ENV216

### 14.2 EMI Test Set-up

LED driver is placed in a conical metal housing (for self-ballasted lamps; CISPR15 Edition 7.2).



**Figure 78** – Conducted Emissions Measurement Set-up  
Showing Conical Ground Plane Inside which UUT was Mounted.

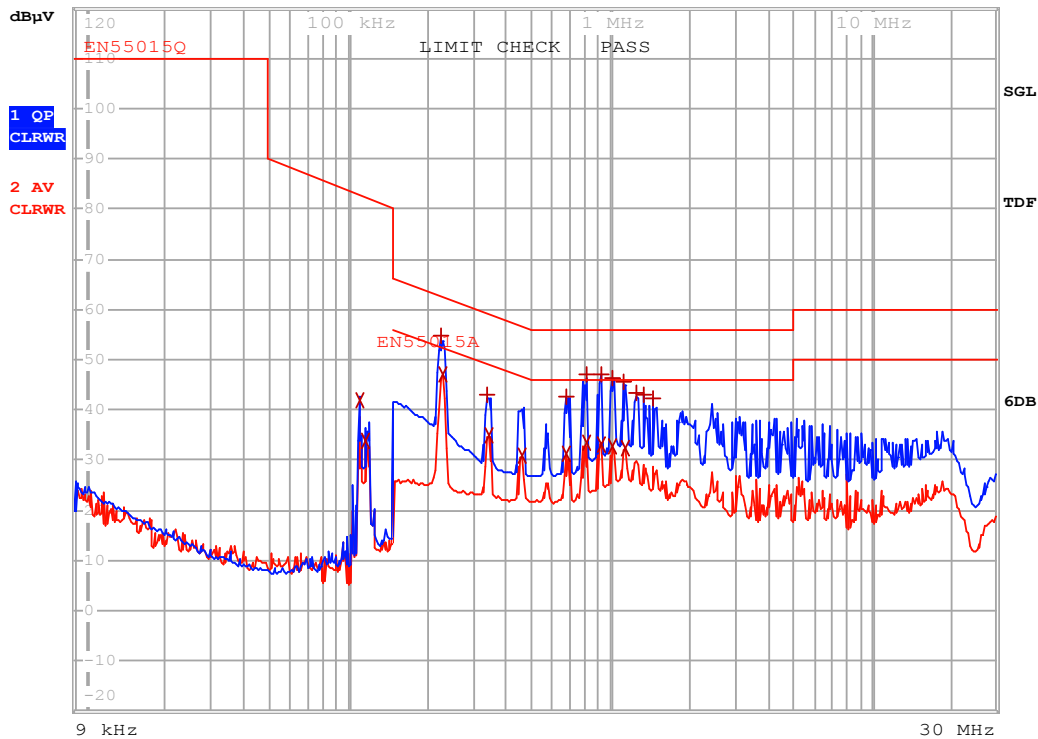
### 14.3 EMI Test Result



Power Integrations  
19.Dec 11 16:50

RBW 9 kHz  
MT 500 ms

Att 10 dB AUTO



**EDIT PEAK LIST (Final Measurement Results)**

TRACE	FREQUENCY	LEVEL dBµV	DELTA LIMIT dB
Trace1:	EN55015Q		
Trace2:	EN55015A		
Trace3:	---		
2 Average	110.466018893 kHz	41.78 L1 gnd	
2 Average	116.100896051 kHz	33.67 L1 gnd	
1 Quasi Peak	225.562855639 kHz	54.62 N gnd	-7.98
2 Average	227.818484195 kHz	47.05 L1 gnd	-5.47
1 Quasi Peak	335.832355405 kHz	43.07 N gnd	-16.23
2 Average	342.582585749 kHz	35.05 N gnd	-14.09
2 Average	461.749566613 kHz	30.99 N gnd	-15.66
1 Quasi Peak	680.675429436 kHz	42.75 N gnd	-13.24
2 Average	680.675429436 kHz	31.28 N gnd	-14.71
1 Quasi Peak	814.188196682 kHz	46.92 N gnd	-9.07
2 Average	814.188196682 kHz	33.43 N gnd	-12.56
1 Quasi Peak	926.622115652 kHz	47.12 L1 gnd	-8.87
2 Average	926.622115652 kHz	33.20 L1 gnd	-12.79
2 Average	1.01343296123 MHz	32.57 L1 gnd	-13.42
1 Quasi Peak	1.02356729084 MHz	46.14 L1 gnd	-9.85
1 Quasi Peak	1.1194604716 MHz	45.41 L1 gnd	-10.59
2 Average	1.13065507631 MHz	32.48 N gnd	-13.51
1 Quasi Peak	1.2489466135 MHz	43.39 N gnd	-12.60
1 Quasi Peak	1.33903981723 MHz	43.16 L1 gnd	-12.84
1 Quasi Peak	1.44998824519 MHz	42.38 L1 gnd	-13.61

Figure 79 – Conducted EMI, 48 V / 90 mA Steady-State Load, 230 VAC, 60 Hz, and EN55015 Limits.



**15 Revision History**

<b>Date</b>	<b>Author</b>	<b>Revision</b>	<b>Description and Changes</b>	<b>Reviewed</b>
24-Jan-12	DS	1.0	Initial Release	Apps & Mktg
20-Mar-12	AS	1.1	Text Updates	



## For the latest updates, visit our website: [www.powerint.com](http://www.powerint.com)

Power Integrations reserves the right to make changes to its products at any time to improve reliability or manufacturability. Power Integrations does not assume any liability arising from the use of any device or circuit described herein. POWER INTEGRATIONS MAKES NO WARRANTY HEREIN AND SPECIFICALLY DISCLAIMS ALL WARRANTIES INCLUDING, WITHOUT LIMITATION, THE IMPLIED WARRANTIES OF MERCHANTABILITY, FITNESS FOR A PARTICULAR PURPOSE, AND NON-INFRINGEMENT OF THIRD PARTY RIGHTS.

### PATENT INFORMATION

The products and applications illustrated herein (including transformer construction and circuits' external to the products) may be covered by one or more U.S. and foreign patents, or potentially by pending U.S. and foreign patent applications assigned to Power Integrations. A complete list of Power Integrations' patents may be found at [www.powerint.com](http://www.powerint.com). Power Integrations grants its customers a license under certain patent rights as set forth at <http://www.powerint.com/ip.htm>.

The PI Logo, TOPSwitch, TinySwitch, LinkSwitch, DPA-Switch, PeakSwitch, CAPZero, SENZero, LinkZero, HiperPFS, HiperTFS, HiperLCS, Qspeed, EcoSmart, Clampless, E-Shield, Filterfuse, StackFET, PI Expert and PI FACTS are trademarks of Power Integrations, Inc. Other trademarks are property of their respective companies. ©Copyright 2011 Power Integrations, Inc.

## Power Integrations Worldwide Sales Support Locations

### WORLD HEADQUARTERS

5245 Hellyer Avenue  
San Jose, CA 95138, USA.  
Main: +1-408-414-9200  
Customer Service:  
Phone: +1-408-414-9665  
Fax: +1-408-414-9765  
e-mail:  
[usasales@powerint.com](mailto:usasales@powerint.com)

### GERMANY

Rueckertstrasse 3  
D-80336, Munich  
Germany  
Phone: +49-89-5527-3911  
Fax: +49-89-5527-3920  
e-mail:  
[eurosales@powerint.com](mailto:eurosales@powerint.com)

### JAPAN

Kosei Dai-3 Building  
2-12-11, Shin-Yokohama,  
Kohoku-ku, Yokohama-shi,  
Kanagawa 222-0033  
Japan  
Phone: +81-45-471-1021  
Fax: +81-45-471-3717  
e-mail: [japansales@powerint.com](mailto:japansales@powerint.com)

### TAIWAN

5F, No. 318, Nei Hu Rd., Sec. 1  
Nei Hu District  
Taipei 114, Taiwan R.O.C.  
Phone: +886-2-2659-4570  
Fax: +886-2-2659-4550  
e-mail:  
[taiwansales@powerint.com](mailto:taiwansales@powerint.com)

### CHINA (SHANGHAI)

Rm 1601/1610, Tower 1  
Kerry Everbright City  
No. 218 Tianmu Road West  
Shanghai, P.R.C. 200070  
Phone: +86-021-6354-6323  
Fax: +86-021-6354-6325  
e-mail:  
[chinasales@powerint.com](mailto:chinasales@powerint.com)

### INDIA

#1, 14<sup>th</sup> Main Road  
Vasanthanagar  
Bangalore-560052  
India  
Phone: +91-80-4113-8020  
Fax: +91-80-4113-8023  
e-mail:  
[indiasales@powerint.com](mailto:indiasales@powerint.com)

### KOREA

RM 602, 6FL  
Korea City Air Terminal B/D, 159-6  
Samsung-Dong, Kangnam-Gu,  
Seoul, 135-728  
Korea  
Phone: +82-2-2016-6610  
Fax: +82-2-2016-6630  
e-mail: [koreasales@powerint.com](mailto:koreasales@powerint.com)

### EUROPE HQ

1st Floor, St. James's House  
East Street, Farnham  
Surrey GU9 7TJ  
United Kingdom  
Phone: +44 (0) 1252-730-141  
Fax: +44 (0) 1252-727-689  
e-mail:  
[eurosales@powerint.com](mailto:eurosales@powerint.com)

### CHINA (SHENZHEN)

3<sup>rd</sup> Floor, Block A, Zhongtuo  
International Business Center,  
No. 1061, Xiang Mei Road,  
FuTian District, ShenZhen,  
China, 518040  
Phone: +86-755-8379-3243  
Fax: +86-755-8379-5828  
e-mail:  
[chinasales@powerint.com](mailto:chinasales@powerint.com)

### ITALY

Via De Amicis 2  
20091 Bresso MI  
Italy  
Phone: +39-028-928-6000  
Fax: +39-028-928-6009  
e-mail:  
[eurosales@powerint.com](mailto:eurosales@powerint.com)

### SINGAPORE

51 Newton Road,  
#19-01/05 Goldhill Plaza  
Singapore, 308900  
Phone: +65-6358-2160  
Fax: +65-6358-2015  
e-mail:  
[singaporesales@powerint.com](mailto:singaporesales@powerint.com)

### APPLICATIONS HOTLINE

World Wide +1-408-414-9660

### APPLICATIONS FAX

World Wide +1-408-414-9760

