

## General Description

The EB1509 is a of easy to use adjustable step-down (buck) switch-mode voltage regulator. The device is available in an adjustable output version. It is capable of driving a 2A load with excellent line and load regulation.

Requiring a minimum number of external components, these regulators are simple to use and include internal frequency compensation, and a fixed-frequency oscillator.

The output voltage is guaranteed to  $\pm 3\%$  tolerance under specified input voltage and output load conditions. The oscillator frequency is guaranteed to  $\pm 15\%$ . External shutdown is included, featuring typically 50  $\mu\text{A}$  standby current. Self protection features include a two stage frequency reducing current limit for the output switch and an over temperature shutdown for complete protection under fault conditions.

The EB1509 is available in SOP8 DIP8 and ESOP8 package.

## Features

- 3.3V,5V and Adjustable output versions
- Output adjustable from 1.23V to 43V
- Fixed 150KHz frequency internal oscillator
- Guaranteed 2A output load current
- Input voltage range up to 45V
- Low power standby mode,  $I_Q$  typically 50  $\mu\text{A}$
- TTL shutdown capability
- Excellent line and load regulation
- High efficiency
- Thermal shutdown and current limit protection
- Available in advantaged SOP8 DIP8 and ESOP8 package

## Applications

- Simple High-efficiency step-down regulator
- On-card switching regulators
- Positive to negative converter
- LCD monitor and LCD TV
- DVD recorder and PDP TV
- Battery charger
- Step-down to 3.3V for microprocessors

## Package Types

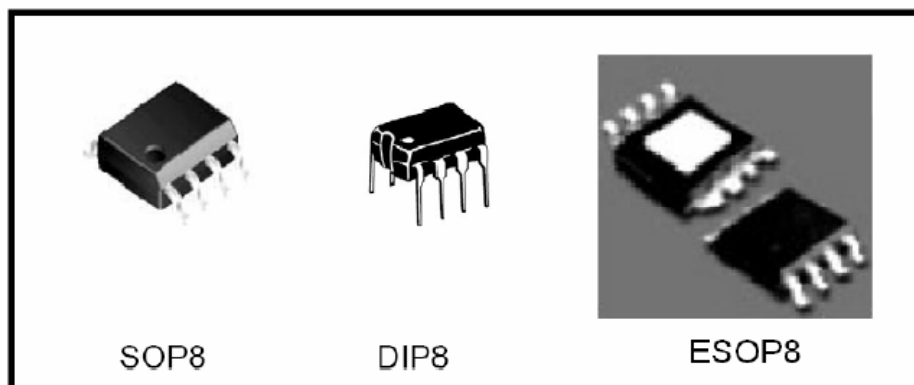
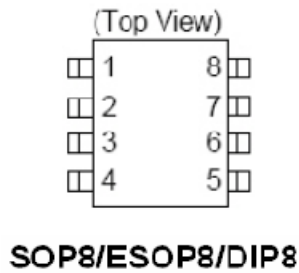

Figure 1. Package Types of EB1509

**Pin Assignments**



**Pin Descriptions**

Pin	Name	Description
1	Vin	Input supply voltage
2	Output	Switching output
5~8	Gnd	Ground
3	Feedback	Output voltage feedback
4	ON/OFF	ON/OFF shutdown Active is "Low" or floating

**Ordering Information**

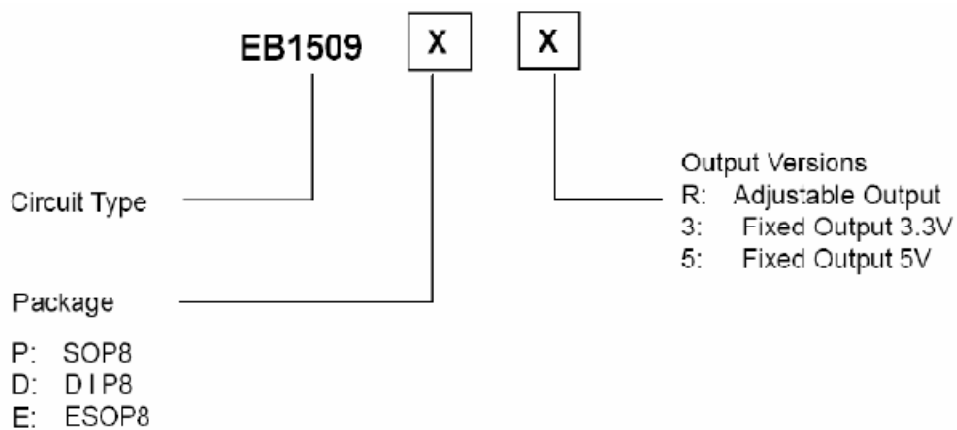

**Functional Block Diagram**

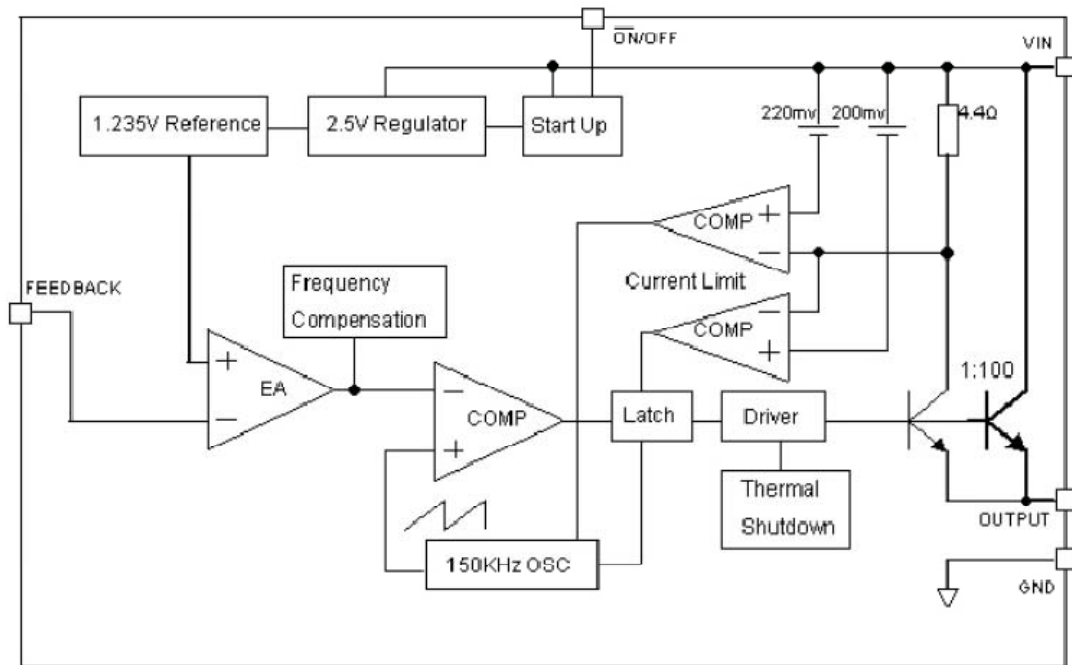
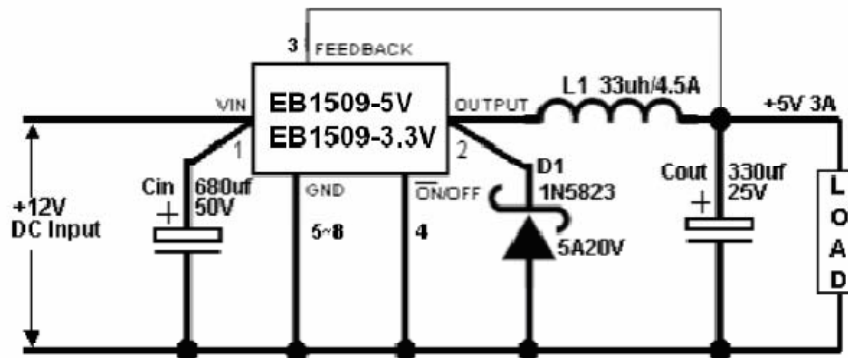

Figure 2. Functional Block Diagram of EB1509

**Typical Application**



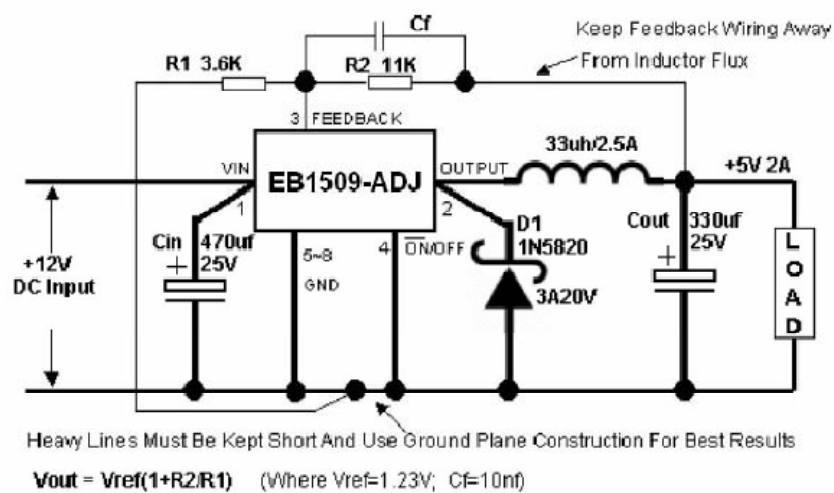

Figure 3. Typical Application of EB1509

### Absolute Maximum Ratings

Note1: Stresses greater than those listed under Maximum Ratings may cause permanent damage to the device. This is a stress rating only and functional operation of the device at these or any other conditions above those indicated in the operation is not implied. Exposure to absolute maximum rating conditions for extended periods may affect reliability.

Parameter	Value	Unit
Supply Voltage $V_{in}$	-0.3 to 45	V
Feedback VFB pin voltage	-0.3 to $V_{in}+0.3$	V
ON/OFF Pin voltage	-0.3 to $V_{in}+0.3$	V
Output pin voltage	-0.3 to $V_{in}+0.3$	V
Output Voltage to Ground (Steady State)	-1	V
Power Dissipation	Internally limited	W
Operating Temperature Range	-40 to +125	°C
Storage Temperature	-65 to +150	°C
Lead Temperature (Soldering, 10 sec)	200	°C
ESD(HM)	2000	V

### Electrical Characteristics

Unless otherwise specified,  $V_{in} = 12V$ ,  $I_{load} = 0.5A$ ,  $T_a = 25^{\circ}C$ .

Symbol	Parameter	Conditions	Min.	Typ.	Max.	Unit
$I_b$	Feedback bias current	$V_{FB}=1.3V$		10	50/100	nA
$I_Q$	Quiescent current	$V_{FB}=12V$ force driver off		5	10	mA
$I_{STBY}$	Standby quiescent current	ON/OFF=5V, $V_{IN}=36V$		50	100	uA
$F_{OSC}$	Oscillator frequency		127	150	173	KHz
$V_{SAT}$	Saturation voltage	$I_{OUT}=2A$		1.10	1.3	V
$I_{CL}$	Current Limit	Peak Current ( $V_{FB}=0V$ )		3.8		A
$I_L$	Output leakage current	Output=0V ( $V_{FB}=12V$ )			50	uA
	Output leakage current	Output=-1V ( $V_{IN}=32V$ )		2	30	mA
$V_{IL}$ $V_{IH}$	ON/OFF pin logic input Threshold voltage	Low (Regulator ON)		1.3	0.6	V
		High (Regulator OFF)	2.0	1.3		V

**2A 150KHZ PWM Buck DC/DC Converter**
**EB1509**

$I_H$ $I_L$	ON/OFF pin input current	$V_{LOGIC}=2.5V$ (Regulator OFF)		5	15	$\mu A$
		$V_{LOGIC}=0.5V$ (Regulator ON)		0.02	5	$\mu A$
$\theta_{JC}$	Thermal Resistance Junction to Case	SOP8/ESOP8/DIP8		10		$^{\circ}C/W$
$\theta_{JA}$	Thermal Resistance Junction to Ambient (Note1)	SOP8/ESOP8/DIP8		40		$^{\circ}C/W$
EB1509 ADJ	Vfb: Output Voltage	$11V \leq V_{IN} \leq 45V, 0.2A \leq I_{LOAD} \leq 2A, V_{OUT}$ for 9V	1.193/ 1.180	1.23	1.267/ 1.280	V
	$\eta$ : Efficiency	$V_{IN}=12V, V_{OUT}=9V, I_{LOAD}=2A$		89		%
EB1509 3.3V	Vout: Output Voltage	$4.75V \leq V_{IN} \leq 45V, 0.2A \leq I_{LOAD} \leq 2A$	3.168/ 3.135	3.3	3.432/ 3.465	V
	$\eta$ : Efficiency	$V_{IN}=12V, I_{LOAD}=2A$		76		%
EB1509 5V	Vout: Output Voltage	$7V \leq V_{IN} \leq 45V, 0.2A \leq I_{LOAD} \leq 2A$	4.800/ 4.750	5.0	5.200/ 5.250	V
	$\eta$ : Efficiency	$V_{IN}=12V, I_{LOAD}=2A$		85		%

Specifications with **boldface type** are for full operating temperature range, the other type are for  $T_J=25^{\circ}C$ .

Note1: Thermal resistance with copper area of approximately 3 in<sup>2</sup>.

Typical Performance Characteristics

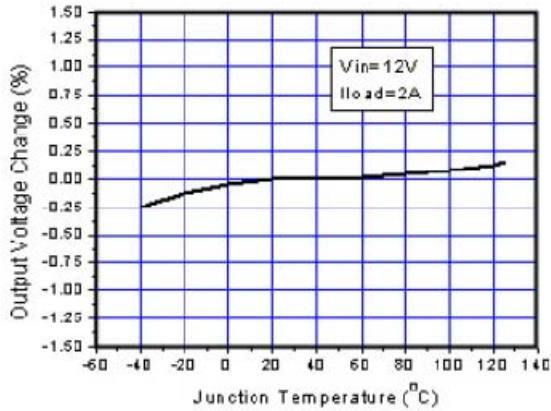

Figure 4. Output Voltage vs. Temperature

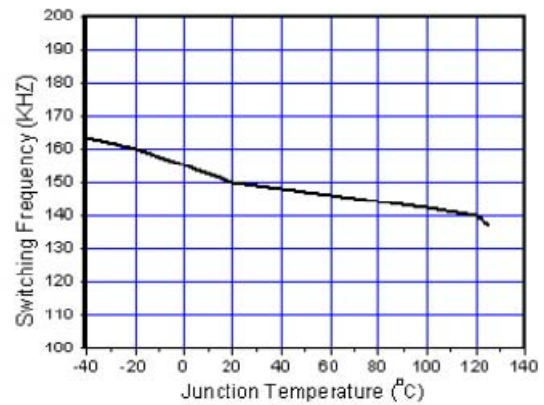

Figure 5. Switching Frequency vs. Temperature

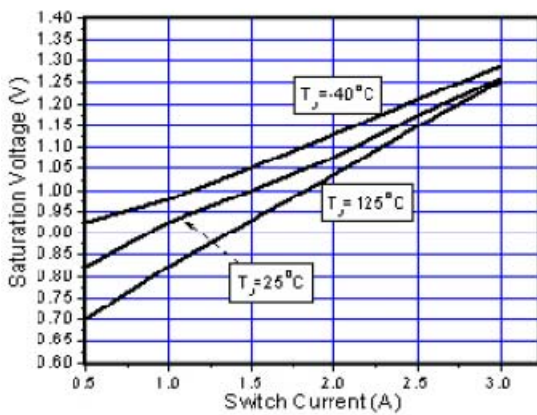

Figure 6. Output Saturation Characteristics

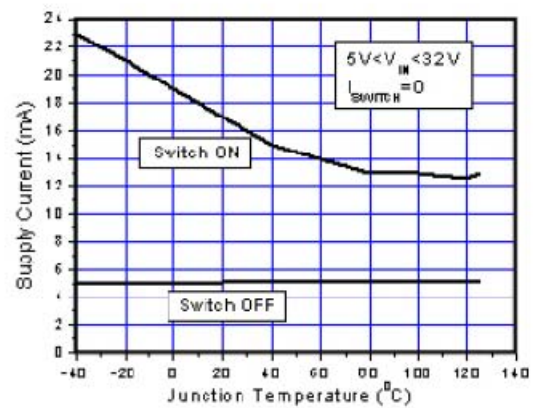

Figure 7. Quiescent Current vs. Temperature

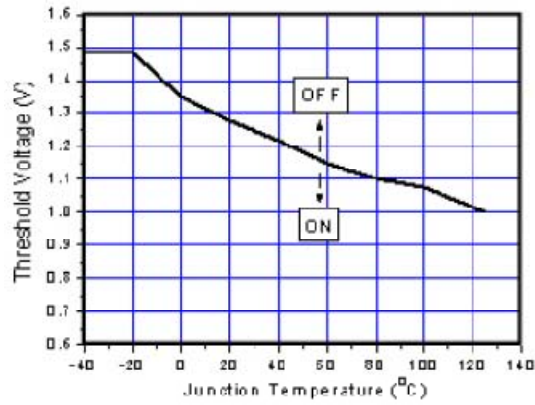

Figure 8. ON/OFF Pin Voltage

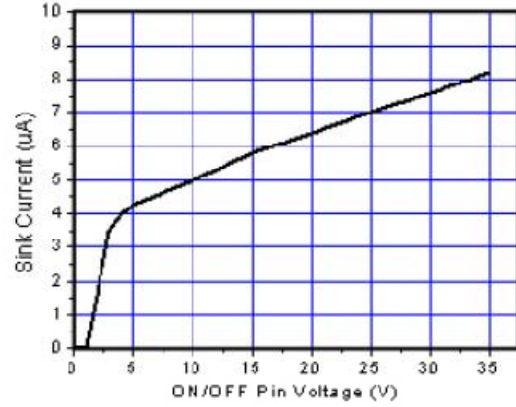

Figure 9. ON/OFF Pin Sink Current

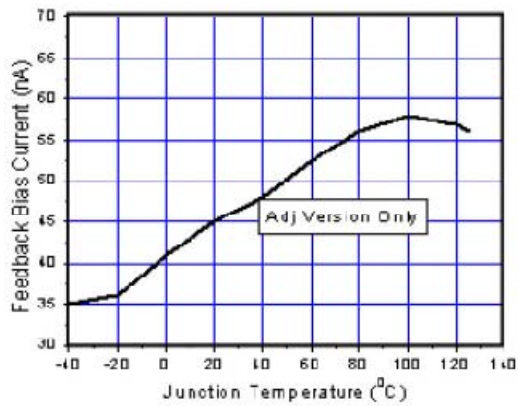

Figure 10. Output Saturation Characteristics



**Typical Application Circuit** (Adjustable Output Voltage Version)

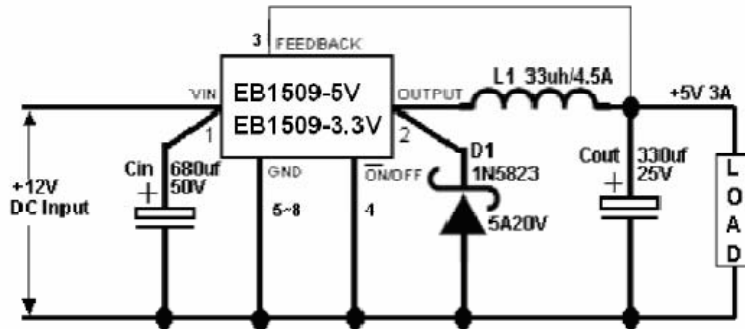

Figure 11. Typical Application of EB1509 For 3.3V 5V

Input Voltage	Inductor (L1)	Output Capacitor (Cout)	
		Through Hole Electrolytic	Surface Mount Tantalum
6V ~ 18V	47uh	470uf/25V	330uf/6.3V
6V ~ 45V	68uh	560uf/25V	330uf/6.3V

Table 1. EB1509 Series Buck Regulator Design Procedure For 3.3V

Input Voltage	Inductor (L1)	Output Capacitor (Cout)	
		Through Hole Electrolytic	Surface Mount Tantalum
8V ~ 18V	33uh	330uf/25V	220uf/10V
8V ~ 45V	47uh	470uf/25V	330uf/10V

Table 2. EB1509 Series Buck Regulator Design Procedure For 5V

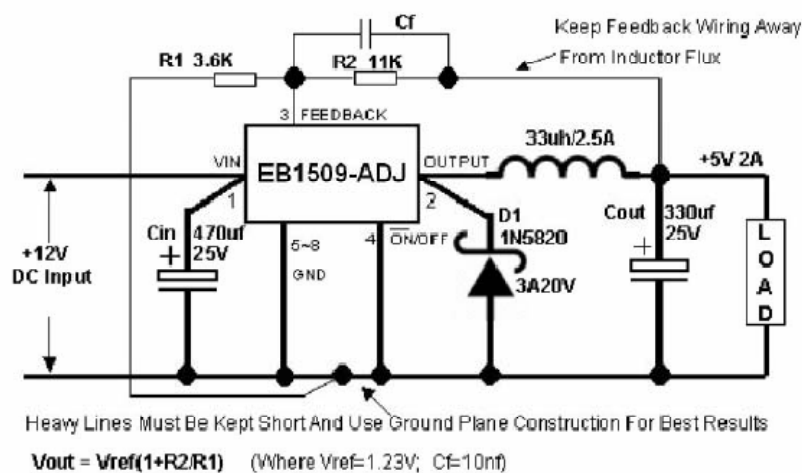

Figure 12. Typical Application of EB1509 For ADJ

Vout	R1	R2	Cf (Operational)
3.3V	1.6K	2.7K	33nf
5V	3.6K	11K	10nf
9V	6.8K	43K	1.5nf
12V	1.5K	13K	1nf

Table 3. Vout VS. R1, R2, Cf Select Table

Output Voltage	Input Voltage	Inductor (L1)	Output Capacitor (Cout)
			Through Hole Electrolytic
3.3V	6V ~ 18V	47µh	470µf/25V
	6V ~ 36V	68µh	560µf/25V
5V	8V ~ 18V	33µh	330µf/25V
	8V ~ 36V	47µh	470µf/25V
9V	12V ~ 18V	47µh	330µf/25V
	12V ~ 36V	47µh	470µf/25V
12V	15V ~ 18V	47µh	220µf/25V
	15V ~ 36V	47µh	330µf/25V

Table 4. Typical Application Buck Regulator Design Procedure

## Function Description

### Pin Functions

#### +V<sub>IN</sub>

This is the positive input supply for the IC switching regulator. A suitable input bypass capacitor must be present at this pin to minimize voltage transients and to supply the switching currents needed by the regulator

#### Ground

Circuit ground.

#### Output

Internal switch. The voltage at this pin switches between (+V<sub>IN</sub> - V<sub>SAT</sub>) and approximately - 0.5V, with a duty cycle of approximately V<sub>OUT</sub> / V<sub>IN</sub>. To minimize coupling to sensitive circuitry, the PC board copper area connected to this pin should be kept a minimum.

#### Feedback

Senses the regulated output voltage to complete the feedback loop.

#### ON/OFF

Allows the switching regulator circuit to be shutdown using logic level signals thus dropping the total input supply current to approximately 50uA. Pulling this pin below a threshold voltage of approximately 1.3V turns the regulator on, and pulling this pin above 1.3V (up to a maximum of 32V) shuts the regulator down. If this shutdown feature is not needed, the ON /OFF pin can be wired to the ground pin or it can be left open, in either case the regulator will be in the ON condition.

### Thermal Considerations

The EB1509 is available in SOP8/DIP8 /ESOP8 package.

The SOP8 package needs a heat sink under most conditions. The size of the heat sink depends on the input voltage, the output voltage, the load current and the ambient temperature. The TD1509 junction temperature rises above ambient temperature for a 2A load and different input and output voltages. The data for these curves was taken with the TD1509 ( SOP8/DIP8/ESOP8 package ) operating as a buck-switching regulator in an ambient temperature of 25°C (still air).

These temperature rise numbers are all approximate and there are many factors that can affect these temperatures. Higher ambient temperatures require more heat sinking.

For the best thermal performance, wide copper traces and generous amounts of printed circuit board copper should be used in the board layout. (Once exception to this is the output (switch) pin, which should not have large areas of copper.) Large areas of copper provide the best transfer of heat (lower thermal resistance) to the surrounding air, and moving air lowers the thermal resistance even further.

Package thermal resistance and junction temperature rise numbers are all approximate, and there are many factors that will affect these numbers. Some of these factors include board size, shape, thickness, position, location, and even board temperature. Other factors are, trace width, total printed circuit copper area, copper thickness, single or double-sided, multi-layer board and the amount of solder on the board.

The effectiveness of the PC board to dissipate heat also depends on the size, quantity and spacing of other components on the board, as well as whether the surrounding air is still or moving. Furthermore, some of these components such as the catch diode will add heat to the PC board and the heat can vary as the input voltage changes. For the inductor, depending on the physical size, type of core material and the DC resistance, it could either act as a heat sink taking heat away from the board, or it could add heat to the board.

**Package Information**

**SOP8 Package Outline Dimensions**

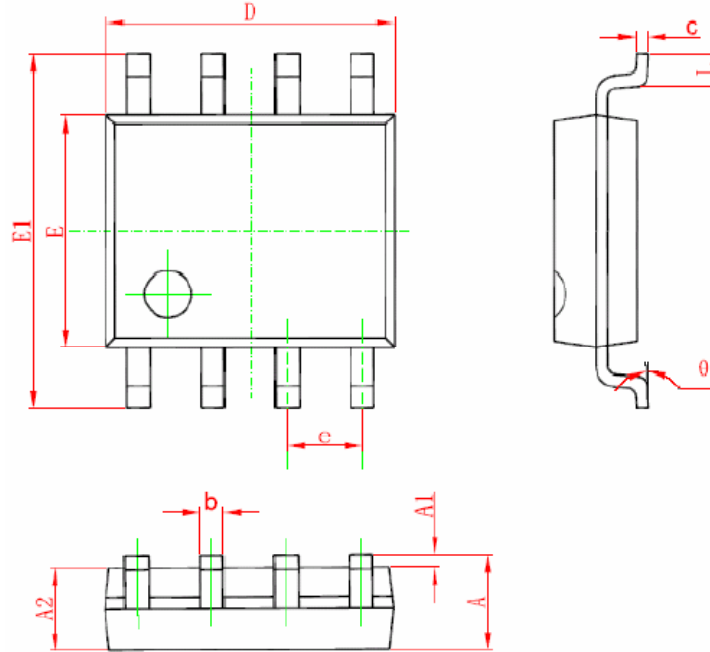

Symbol	Dimensions In Millimeters		Dimensions In Inches	
	Min	Max	Min	Max
A	1.350	1.750	0.053	0.069
A1	0.100	0.250	0.004	0.010
A2	1.350	1.550	0.053	0.061
b	0.330	0.510	0.013	0.020
c	0.170	0.250	0.006	0.010
D	4.700	5.100	0.185	0.200
E	3.800	4.000	0.150	0.157
E1	5.800	6.200	0.228	0.244
e	1.270 (BSC)		0.050 (BSC)	
L	0.400	1.270	0.016	0.050
$\theta$	0°	8°	0°	8°

**Package Information**  
**DIP8 Package Outline Dimensions**

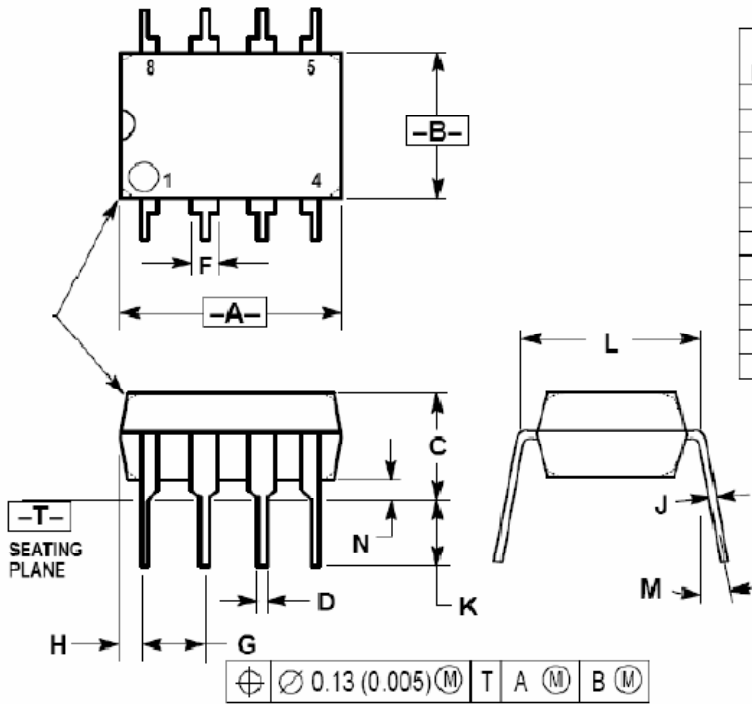

DIM	MILLIMETERS		INCHES	
	MIN	MAX	MIN	MAX
A	9.40	10.16	0.370	0.400
B	6.10	6.60	0.240	0.260
C	3.94	4.45	0.155	0.175
D	0.38	0.51	0.015	0.020
F	1.02	1.78	0.040	0.070
G	2.54 BSC		0.100 BSC	
H	0.76	1.27	0.030	0.050
J	0.20	0.30	0.008	0.012
K	2.92	3.43	0.115	0.135
L	7.62 BSC		0.300 BSC	
M	—	10°	—	10°
N	0.76	1.01	0.030	0.040

**Package Information**  
**ESOP8 Package Outline Dimensions**

