



The Future of Analog IC Technology®

# MP1517

25V, 3A  
Step-Up Converter

## DESCRIPTION

The MP1517 is a 3A, fixed frequency step-up converter ideal for medium-to-high current step-up, flyback, and SEPIC applications. The high 1.1MHz switching frequency allows for smaller external components producing a compact solution for size constrained cameras, PDAs and cell phones. The low 0.7V feedback voltage offers higher efficiency in white LED driver applications including cell phone camera flash. The MP1517 regulates the output voltage up to 25V with efficiencies as high as 95%. Soft-start, cycle-by-cycle current limiting, and input under voltage lockout prevent overstressing or damage to sensitive external circuitry at startup and output short-circuit conditions. Current-mode regulation and external compensation components allow the MP1517 control loop to be optimized over a wide variety of input voltage, output voltage, and load current conditions. The MP1517 is available in the thermally enhanced 4mm x 4mm QFN package.

## FEATURES

- 4A Peak Current Limit
- Low 700mV Feedback Threshold
- Internal 150mΩ Power Switch
- Input Range of 2.6V to 25V
- Efficiency up to 95%
- Zero Current Shutdown Mode
- Under Voltage Lockout Protection
- Open Load Protection
- Soft-Start Operation
- Thermal Shutdown
- Tiny 4mm x 4mm 16-Pin QFN Package

## APPLICATIONS

- Boost and SEPIC Regulators
- Handheld Computers
- Cell Phone Camera Flash, PDAs
- Digital Still and Video Cameras

"MPS" and "The Future of Analog IC Technology" are Registered Trademarks of Monolithic Power Systems, Inc.

## EVALUATION BOARD REFERENCE

Board Number	Dimensions
EV0043	2.5"X x 2.0"Y x 0.4"Z

## TYPICAL APPLICATION

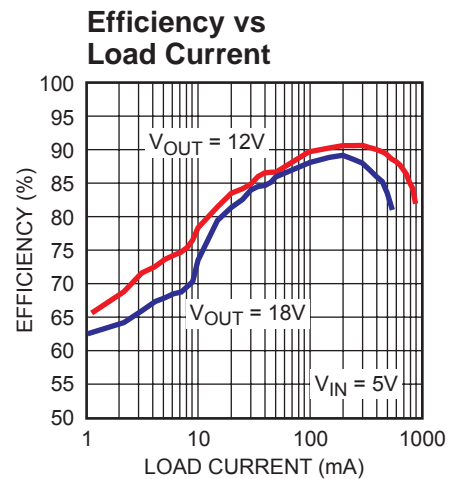
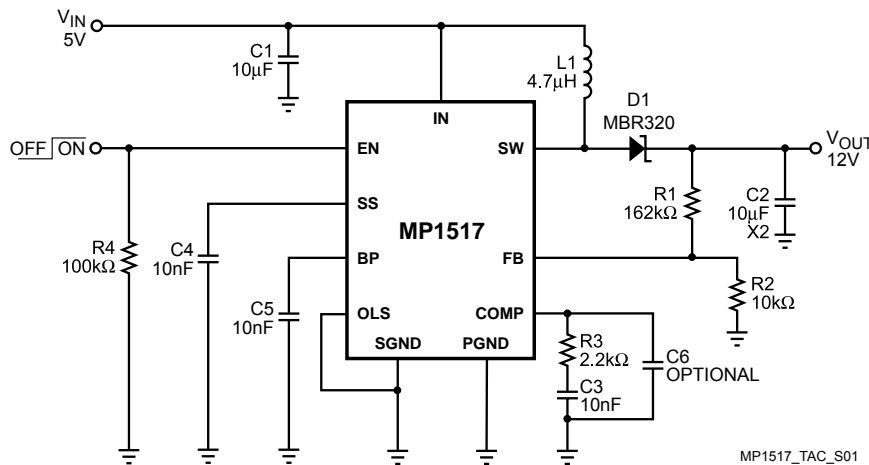

## PACKAGE REFERENCE

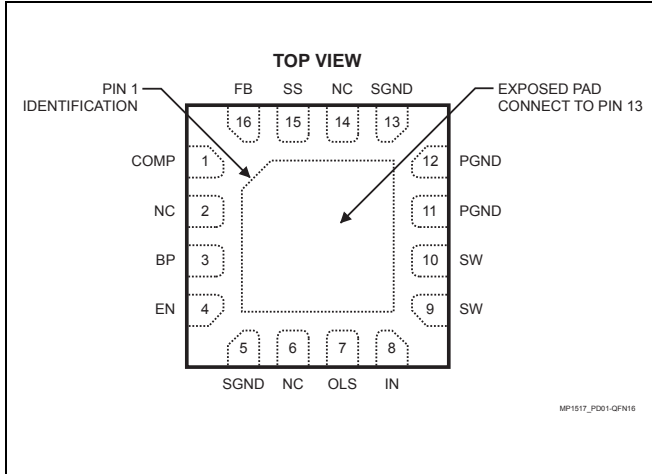

Part Number*	Package	Temperature
MP1517DR	QFN16-4	-40°C to +85°C

\* For Tape & Reel, add suffix -Z (eg. MP1517DR-Z)  
For Lead Free, add suffix -LF (eg. MP1517DR-LF-Z)

## ABSOLUTE MAXIMUM RATINGS <sup>(1)</sup>

Input Supply Voltage  $V_{IN}$  ..... -0.3V to 27V  
 SW Pin Voltage  $V_{SW}$  ..... -0.3V to 27V  
 Voltage at All Other Pins except OLS. -0.3V to 6V  
 Storage Temperature ..... -65°C to +150°C  
 Junction Temperature ..... +150°C

## Recommended Operating Conditions <sup>(2)</sup>

IN Input Supply Voltage  $V_{IN}$  ..... 2.6V to 25V  
 Output Voltage ..... 3.3V to 25V  
 Operating Temperature ..... -40°C to +85°C

**Thermal Resistance <sup>(3)</sup>**     $\theta_{JA}$      $\theta_{JC}$   
 QFN16-4 ..... 46 ..... 10... °C/W

### Notes:

- Exceeding these ratings may damage the device.
- The device is not guaranteed to function outside of its operating conditions.
- Measured on approximately 1" square of 1 oz. Copper.

## ELECTRICAL CHARACTERISTICS

$V_{IN} = 5.0V$ ,  $T_A = 25^\circ C$ , unless otherwise noted.

Parameter	Symbol	Condition	Min	Typ	Max	Units
IN Shutdown Supply Current		$V_{EN} \leq 0.3V$		0.5	1.0	$\mu A$
IN Operating Supply Current		$V_{EN} > 2V$ , $V_{FB} = 0.8V$		0.9	1.2	mA
BP Output Voltage		$V_{IN} = 2.6V$ to 25V		2.4		V
IN Undervoltage Lockout Threshold		$V_{IN}$ Rising	2.10		2.40	V
IN Undervoltage Lockout Hysteresis				100		mV
EN Input Low Voltage					0.4	V
EN Input High Voltage			1.5			V
EN Input Hysteresis				100		mV
EN Input Bias Current					1	$\mu A$
SW Switching Frequency	$f_{SW}$		0.9	1.1	1.3	MHz
SW Maximum Duty Cycle		$V_{FB} = 0.6V$	85	93		%
Error Amplifier Voltage Gain <sup>(4)</sup>	$A_{VEA}$			400		V/V
Error Amplifier Transconductance	$G_{EA}$			350		$\mu A/V$
COMP Maximum Output Current		Sourcing and Sinking		30		$\mu A$
FB Regulation Threshold			679	700	721	mV
FB Input Bias Current		$V_{FB} = 0.7V$			1	$\mu A$
SS Charging Current		During Soft-Start		2		$\mu A$

**ELECTRICAL CHARACTERISTICS (continued)**
 $V_{IN} = 5.0V$ ,  $T_A = 25^\circ C$ , unless otherwise noted.

Parameter	Symbol	Condition	Min	Typ	Max	Units
SW On Resistance <sup>(4)</sup>		$V_{IN} = 5V$		150		m $\Omega$
		$V_{IN} = 3V$		225		m $\Omega$
SW Current Limit <sup>(4)</sup>			3.0	4.0		A
SW Leakage Current		$V_{SW} = 25V$		0.5		$\mu A$
Thermal Shutdown <sup>(4)</sup>				160		$^\circ C$
Open Load Shutdown Threshold		Measured at OLS Pin		27		V

**Note:**

4) Guaranteed by design.

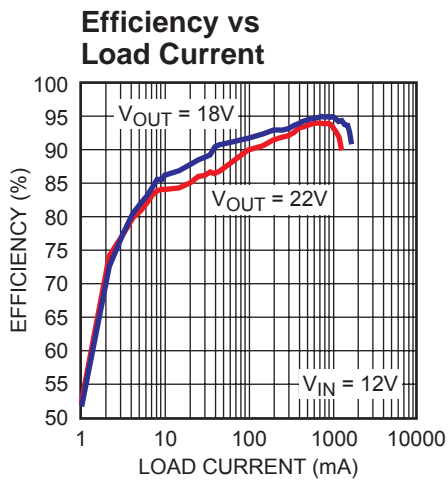
**TYPICAL PERFORMANCE CHARACTERISTICS**

MP1517-EC01

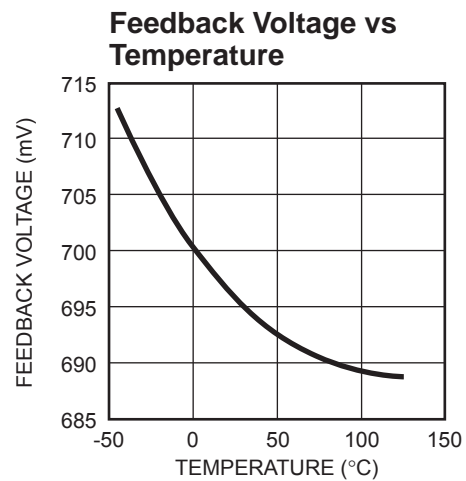

MP1517-TPC01

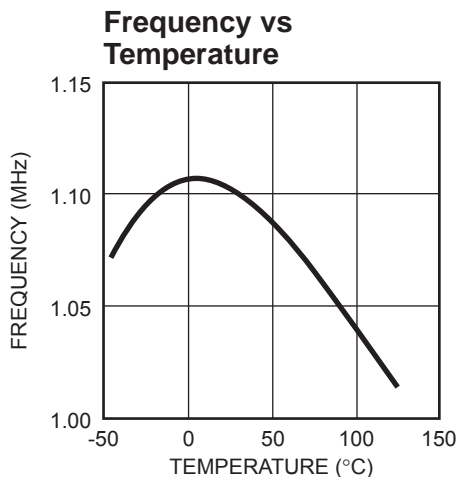

MP1517-TPC02

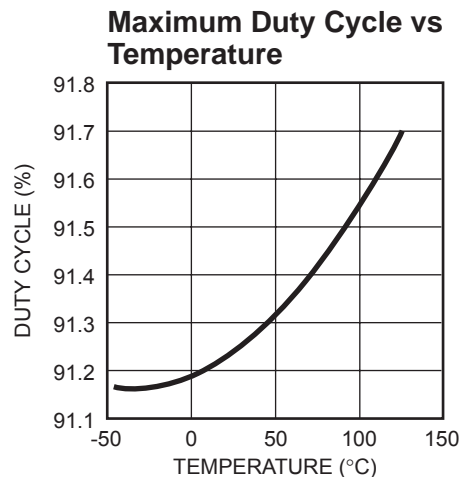

MP1517-TPC03

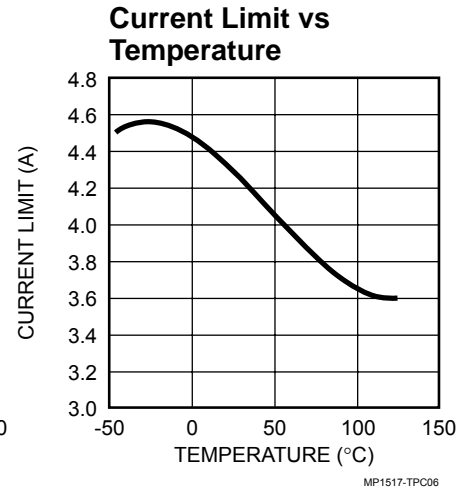
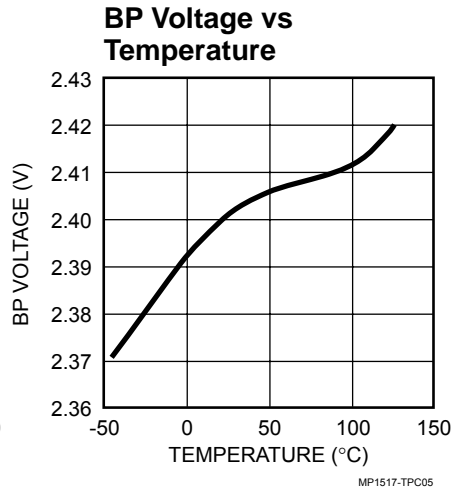
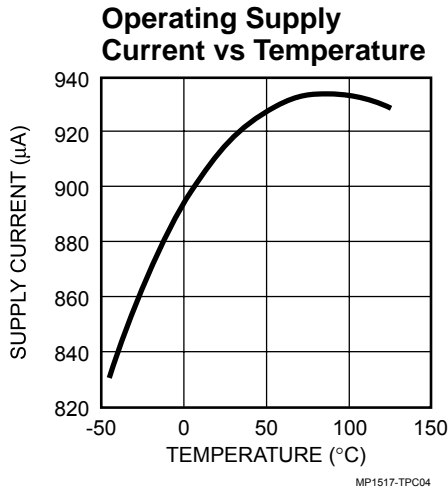
**TYPICAL PERFORMANCE CHARACTERISTICS** *(continued)*

**PIN FUNCTIONS**

Pin #	Name	Description
1	COMP	Compensation: Error Amplifier Output. Connect to a series RC network to compensate the regulator control loop.
2, 6, 14	NC	No Connect
3	BP	Output of the Internal 2.4V Low Dropout Regulator. Connect a 10nF bypass capacitor between BP and SGND. Do not apply an external load to BP.
4	EN	Regulator On/Off Control Input. A logic high input ( $V_{EN} > 1.5V$ ) turns on the regulator, a logic low puts it into low current shutdown mode. <b>The EN pin cannot be left floating.</b>
5, 13	SGND	Signal Ground
7	OLS	Open Load Shutdown Pin. OLS senses regulator output voltage to protect IC during open load operation. When this pin's voltage exceeds 27V, the output switch is shut off. The device then restarts in soft-start mode until it is disabled.
8	IN	Input Supply Pin. This pin can be connected to the regulator's input supply or to the output for boot-strapped operation.
9, 10	SW	Output Switch Node. SW is the drain of the internal N-Channel MOSFET. Connect the inductor and rectifier to SW to complete the step-up converter.
11, 12	PGND	Power Ground
15	SS	Soft-Start Input. Connect a 10nF to 22nF capacitor from SS to SGND to set the soft-start time. SS sources 2µA to an external soft-start capacitor during startup. As the voltage at SS increases to 0.55V, the voltage at COMP is clamped to 0.7V above the voltage at SS limiting the startup current. The external capacitor at SS is discharged to ground when under voltage lockout, thermal shutdown occurs or open load shutdown occurs.
16	FB	Regulation Feedback Input. The regulation threshold is 0.7V.

## OPERATION

The MP1517 uses a 1.1MHz fixed-frequency, current-mode regulation architecture to regulate the output. The operation of the MP1517 can be understood by referring to the block diagram of Figure 1. At the beginning of each cycle, the N-Channel MOSFET switch is turned on, forcing the inductor current to rise. The current at the source of the switch is internally measured and converted to a voltage by the current sense amplifier. That voltage is compared to the error voltage at COMP. The voltage at the output of the error amplifier is an amplified version of the difference between the 700mV reference

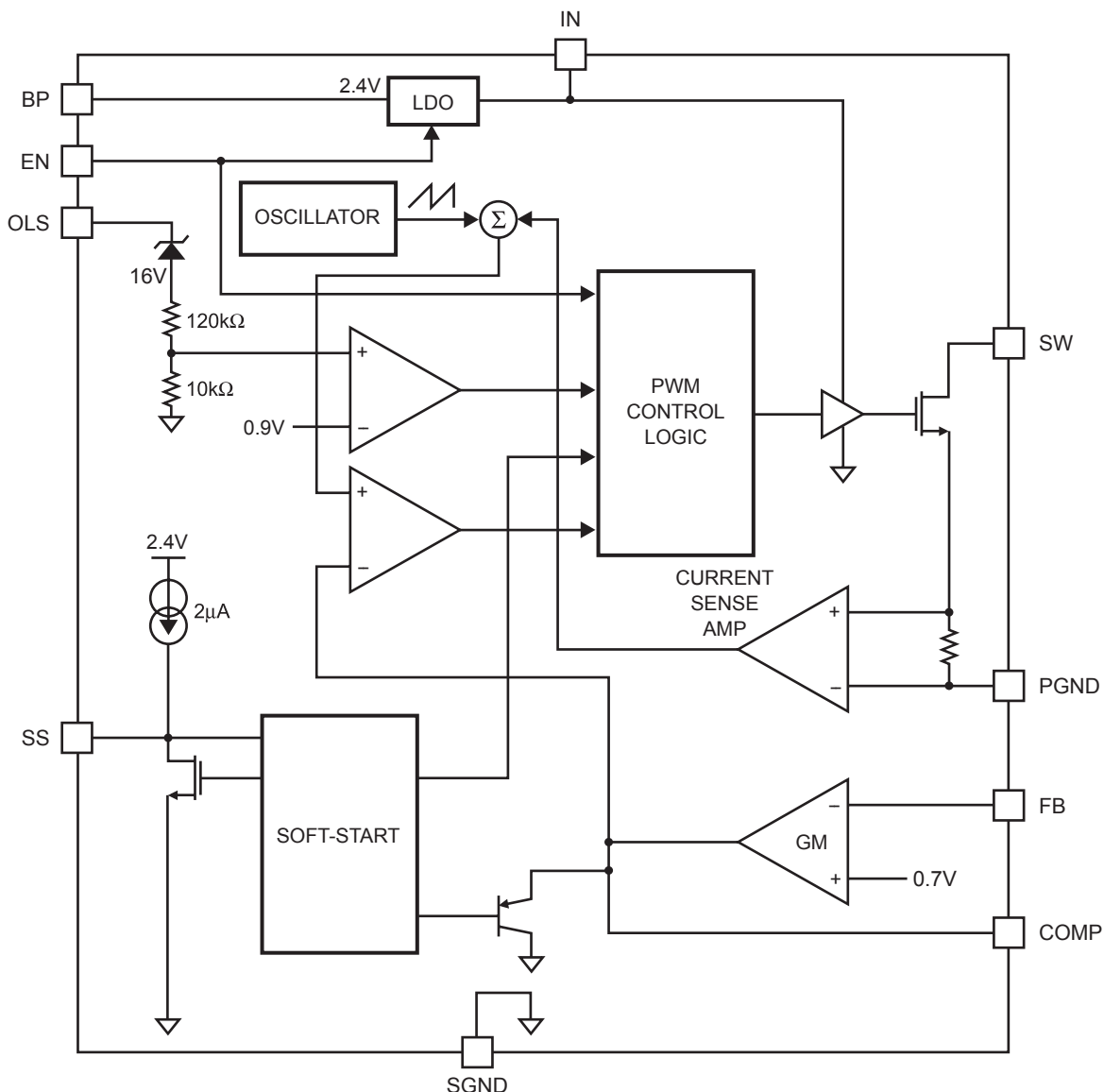
voltage and the feedback voltage. When these two voltages are equal, the PWM comparator turns off the switch forcing the inductor current to the output capacitor through the external rectifier. This causes the inductor current to decrease. The peak inductor current is controlled by the voltage at COMP, which in turn is controlled by the output voltage. Thus the output voltage controls the inductor current to satisfy the load. The use of current-mode regulation improves transient response and control loop stability.



MP1517\_BD01

**Figure 1—Functional Block Diagram**

### Internal Low-Dropout Regulator

The internal power to the MP1517 is supplied from the IN pin through an internal 2.4V low-dropout linear regulator, whose output is BP. Bypass BP to SGND with a 10nF or greater capacitor to insure the MP1517 operates properly. The internal regulator can not supply any more current than is required to operate the MP1517, therefore do not apply any external load to BP.

### Soft-Start

The MP1517 includes a soft-start timer that limits the voltage at COMP during startup to prevent excessive current at the input. This prevents premature termination of the source voltage at startup due to input current overshoot. When power is applied to the MP1517, and enable is asserted, a 2µA internal current source charges the external capacitor at SS. As the capacitor

charges, the voltage at SS rises. The MP1517 internally clamps the voltage at COMP to 700mV above the voltage at SS. This limits the inductor current at start-up, forcing the input current to rise slowly to the current required to regulate the output voltage.

### Open Load Shutdown

The MP1517 includes an open load detect that will stop the output from switching. In a fault condition where the connection to the LED's is open,  $V_{OUT}$  will rise up. Once  $V_{OUT}$  exceeds 27V, the MP1517 will stop switching and the output will stop rising. When the output falls below 27V the MP1517 will restart in soft-start mode and switches until the OLS threshold is exceeded again. This will continue until the part is disabled. To disable the open load shutdown feature, connect the OLS pin to GND.

## APPLICATION INFORMATION

### GENERAL PURPOSE COMPONENT SELECTION

#### Setting the Output Voltage

Set the output voltage by selecting the resistive voltage divider ratio. Use 10kΩ to 50kΩ for the low-side resistor R2 of the voltage divider. Determine the high-side resistor R1 by the equation:

$$R1 = \frac{R2(V_{OUT} - V_{FB})}{V_{FB}}$$

where  $V_{OUT}$  is the output voltage.

For  $R2 = 10k\Omega$  and  $V_{FB} = 0.7V$ , then

$R1 (k\Omega) = 14.29k\Omega (V_{OUT} - 0.7V)$ .

#### Selecting the Inductor

The inductor is required to force the higher output voltage while being driven by the input voltage. A larger value inductor results in less ripple current, resulting in lower peak inductor current and reducing stress on the internal N-Channel MOSFET switch. However, the larger value inductor has a larger physical size, higher series resistance, and/or lower saturation current.

Choose an inductor that does not saturate under the worst-case load transient and startup

conditions. A good rule for determining the inductance is to allow the peak-to-peak ripple current to be approximately 30% to 50% of the maximum input current. Make sure that the peak inductor current is below 3A to prevent loss of regulation due to the current limit. Calculate the required inductance value by the equation:

$$L = \frac{V_{IN}(V_{OUT} - V_{IN})}{V_{OUT} \times f_{SW} \times \Delta I}$$

$$I_{IN(MAX)} = \frac{V_{OUT} \times I_{LOAD(MAX)}}{V_{IN} \times \eta}$$

$$\Delta I = (30\% - 50\%) I_{IN(MAX)}$$

Where  $V_{IN}$  is the input voltage,  $f_{SW}$  is the switching frequency,  $I_{LOAD(MAX)}$  is the maximum load current,  $\Delta I$  is the peak-to-peak inductor ripple current and  $\eta$  is the efficiency.

#### Selecting the Input Capacitor

An input capacitor is required to supply the AC ripple current to the inductor, while limiting noise at the input source. A low ESR capacitor is required to keep the noise at the IC to a minimum. Ceramic capacitors are preferred, but tantalum or low-ESR electrolytic capacitors may also suffice.

Use an input capacitor value greater than 10 $\mu$ F. The capacitor can be electrolytic, tantalum or ceramic. However since it absorbs the input switching current it requires an adequate ripple current rating. Use a capacitor with RMS current rating greater than the inductor ripple current.

To insure stable operation place the input capacitor as close to the IC as possible. Alternately a smaller high quality ceramic 0.1 $\mu$ F capacitor may be placed closer to the IC with the larger capacitor placed further away. If using this technique, it is recommended that the larger capacitor be a tantalum or electrolytic type. All ceramic capacitors should be placed close to the MP1517.

### Selecting the Output Capacitor

The output capacitor is required to maintain the DC output voltage. Low ESR capacitors are preferred to keep the output voltage ripple to a minimum. The characteristic of the output capacitor also affects the stability of the regulation control system. Ceramic, tantalum, or low ESR electrolytic capacitors are recommended. In the case of ceramic capacitors, the impedance of the capacitor at the switching frequency is dominated by the capacitance, and so the output voltage ripple is mostly independent of the ESR. The output voltage ripple is calculated as:

$$V_{\text{RIPPLE}} = \frac{I_{\text{LOAD}}(V_{\text{OUT}} - V_{\text{IN}})}{V_{\text{OUT}} \times C2 \times f_{\text{SW}}}$$

Where  $V_{\text{RIPPLE}}$  is the output ripple voltage,  $V_{\text{IN}}$  and  $V_{\text{OUT}}$  are the DC input and output voltages respectively,  $I_{\text{LOAD}}$  is the load current,  $f_{\text{SW}}$  is the switching frequency, and C2 is the capacitance of the output capacitor.

In the case of tantalum or low-ESR electrolytic capacitors, the ESR dominates the impedance at the switching frequency, and so the output ripple is calculated as:

$$V_{\text{RIPPLE}} = I_{\text{LOAD}} \times \left[ \frac{(V_{\text{OUT}} - V_{\text{IN}})}{V_{\text{OUT}} \times f_{\text{SW}} \times C2} + \frac{\text{ESR} \times V_{\text{OUT}}}{V_{\text{IN}}} \right]$$

Where ESR is the equivalent series resistance of the output capacitors.

Choose an output capacitor to satisfy the output ripple and load transient requirements of the

design. Place the output capacitor close to SW to minimize the AC loop and switching noise.

### Selecting the Diode

The output rectifier diode supplies current to the inductor when the internal MOSFET is off. To reduce losses due to diode forward voltage and recovery time, use a Schottky diode. Choose a diode whose maximum reverse voltage rating is greater than the maximum output voltage. The rated average forward current needs to be equal to or greater than the load current.

### Selecting the Soft-Start Capacitor

The soft-start period is determined by the equation:

$$t_{\text{SS}} = 0.275 \times C4$$

Where  $C_{\text{SS}}$  (in nF) is the soft-start capacitor from SS to SGND, and  $t_{\text{SS}}$  (in ms) is the soft-start period.

Determine the capacitor required for a given soft-start period by the equation:

$$C4 = 3.64 \times t_{\text{SS}}$$

It is recommended that values between 10nF and 22nF for  $C_{\text{SS}}$  be used to set the soft-start period.

### Compensation

The output of the transconductance error amplifier (COMP) is used to compensate the regulation control system. The system uses two poles and one zero to stabilize the control loop. The poles are  $f_{\text{P1}}$  set by the output capacitor and load resistance and  $f_{\text{P2}}$  set by the compensation capacitor C3. The zero  $f_{\text{Z1}}$  is set by the compensation capacitor C3 and the compensation resistor R3.

These are determined by the equations:

$$f_{\text{P1}} = \frac{1}{\pi \times C2 \times R_{\text{LOAD}}}$$

$$f_{\text{P2}} = \frac{G_{\text{EA}}}{2 \times \pi \times C3 \times A_{\text{VEA}}}$$

$$f_{\text{Z1}} = \frac{1}{2 \times \pi \times C3 \times R3}$$

Where  $R_{\text{LOAD}}$  is the load resistance,  $G_{\text{EA}}$  is the error amplifier transconductance, and  $A_{\text{VEA}}$  is the error amplifier voltage gain.



The DC loop gain is:

$$A_{VDC} = \frac{7 \times A_{VEA} \times V_{IN} \times R_{LOAD} \times V_{FB}}{V_{OUT}^2}$$

Where  $V_{FB}$  is the feedback regulation threshold.

There is also a right-half-plane zero ( $f_{RHPZ}$ ) that exists in the continuous conduction mode (inductor current does not drop to zero on each cycle) step-up converters. The frequency of the right-half plane zero is:

$$f_{RHPZ} = \frac{V_{IN}^2 \times R_{LOAD}}{2 \times \pi \times L \times V_{OUT}^2}$$

To stabilize the regulation control loop, the crossover frequency (The frequency where the loop gain drops to 0dB or a gain of 1, indicated as  $f_C$ ) should be less than half of  $f_{RHPZ}$  and should be at most 75KHz.  $f_{RHPZ}$  is at its lowest frequency at maximum output load current.

In some cases, an output capacitor with a high capacitance and high equivalent series

resistance (ESR) is used, then a second compensation capacitor (from COMP to SGND) is required to compensate for the zero introduced by the output capacitor ESR. The extra capacitor is required if the ESR zero is less than 4x the crossover frequency. The ESR zero frequency is:

$$f_{ZESR} = \frac{1}{2 \times \pi \times C2 \times R_{ESR}}$$

If this is the case, calculate the second compensation capacitor by the equation:

$$C6 = \frac{C2 \times R_{ESR}}{R3}$$

For most applications  $C4$  is not required. Typical values for the compensation components are:

$$C3 = 10nF$$

$$R3 = 2.2k\Omega$$

## SEPIC CONVERTER COMPONENT SELECTION

### Selecting the Input Capacitor

An input capacitor is required to supply the AC ripple current to the inductor, while limiting noise at the input source. The input capacitor selection is the same as that in the General Purpose Component Selection section above.

### Selecting the Inductors

The SEPIC converter inductors (refer to Fig. 4) are required to store energy, and generate an output voltage that is less than or greater than the input voltage. If a coupled inductor is used in a SEPIC converter, then the mutual inductance of each winding forces each inductor to become twice the original inductance. Therefore smaller inductance can be used with a coupled inductor. But the core saturation of the coupled inductors is related to the sum of both inductor currents.

There are two current paths to the internal N-Channel MOSFET switch in a SEPIC converter. One is from L1 and the other is from L2. Each inductor's ripple current can be defines as:

$$L1 = \frac{V_{IN} \times D}{f_{SW} \times \Delta I}$$

$$L2 = \frac{V_{OUT} \times (1 - D)}{f_{SW} \times \Delta I}$$

$$D = \frac{V_{OUT} + V_D}{V_{OUT} + V_D + V_{IN}}$$

Where  $V_D$  is the voltage drop on diode D1, and  $\Delta I$  is the peak to peak inductor ripple current. Set  $\Delta I$  to approximately 20% of the maximum switch current. Each inductor's peak current is:

$$I_{L1(PEAK)} = \frac{\Delta I}{2} + I_{LOAD} \times \frac{V_O + V_D}{V_{IN}}$$

$$I_{L2(PEAK)} = \frac{\Delta I}{2} + I_{LOAD} \times \frac{V_{IN} + V_D}{V_{IN}}$$

The total of these two currents is the total switch current, and should be less than the minimum device current limit of 3A.



### Selecting the Output Diode

The output diode is typically a Schottky diode. The Schottky diode is selected based upon voltage requirement, current rating, and thermal capability. The diode breakdown and power switch breakdown voltage are set higher than  $V_{OUT} + V_{IN}$ , since this is the voltage stress on both of these devices. The current rating is set based on the average load current in the diode. The average diode current is equal to the load current, but the peak current and power consumption on D1 is:

$$I_{D1(PEAK)} = \frac{\Delta I}{2} + I_{LOAD} \times \frac{V_{IN} + V_D}{V_{IN}}$$

$$P_{D1} = I_{LOAD} \times V_D$$

### Setting the Coupling Capacitor

The steady state voltage across L1 and L2 is equal to zero. Therefore the coupling capacitor has  $V_{IN}$  across in steady state. The coupling capacitor will need to be rated for an input voltage plus some guard band. Also this capacitor will need an  $I_{RMS}$  ripple current rating:

$$I_{C8(RMS)} = I_{LOAD} \times \sqrt{\frac{V_O + V_D}{V_{IN}}}$$

### Application Examples

Figure 2 shows a typical application circuit driving multiple strings of LEDs with the MP1517. The 3 strings of 6 white LEDs can be driven from a voltage supply range of 2.6V to 6V at an output current of 20mA. A 1 $\mu$ F output capacitor is usually sufficient for this kind of application. A 4.7 $\mu$ H inductor with low DCR (inductor resistance) is recommended to improve efficiency. A 10 $\mu$ F ceramic capacitor is recommended for the input capacitance. Schottky diodes have fast recovery and a low forward voltage and are recommended. The MP1517 soft-start helps to limit the amount of current through  $V_{IN}$  at startup and to also limit the amount of overshoot on the output.

Figure 3 shows a typical application running the MP1517 in flash mode. During preview mode, resistor R2 sets the current through the white LEDs to 20mA. When a flash is required the N-Channel MOSFET Q1 is turned on and 150mA flows through the LEDs. The compensation capacitor has been increased to 47nF. This forces the compensation node to slowly rise when Q1 is turned on which allows the current through the inductor to slowly increase without overshoot. By doing this the inrush current on the input is minimized.

Figure 4 shows a SEPIC circuit using the MP1517 to generate 3.3V output from a 3V to 4.2V input. A peak voltage detect circuit (D2 and C7) is added to the IN pin from the highest voltage potential (SW node) in the entire circuit. The average voltage on C7 is roughly the sum of  $V_{IN}$  and  $V_{OUT}$ . This ensures the enhancement of the internal MOSFET switch. A transformer with two windings can be used to replace the two separate inductors in Figure 4. In this case, the effective inductance value is doubled due to the mutual inductance of each winding. This reduces the inductor ripple current and improves efficiency. Figures 5 and 6 show some other SEPIC application circuits.

### Layout Consideration

High frequency switching regulators require very careful layout for stable operation and low noise. All components must be placed as close to the IC as possible. Keep the path between L1, D1, and C2 (also L2, C8 if applicable) extremely short for minimal noise and ringing. C1 must be placed close to the IN pin for best decoupling. All feedback components must be kept close to the FB pin to prevent noise injection on the FB pin trace. The ground return of C1 and C2 should be tied close to the PGND pin. See the MP1517 demo board layout for reference.

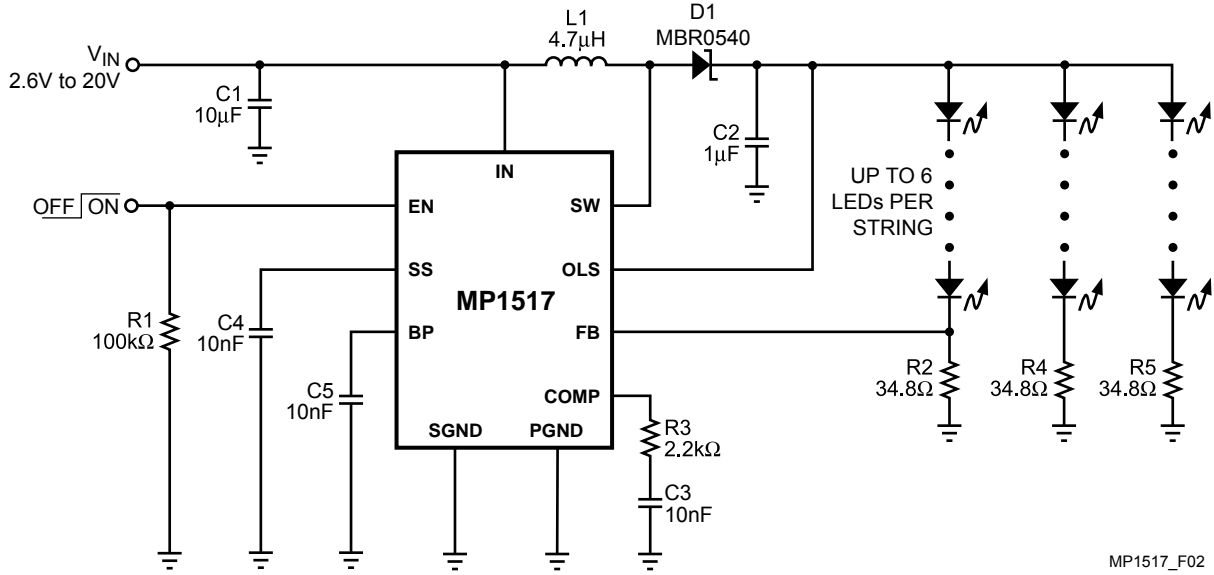

Figure 2—Driving 3 Strings of 6 White LEDs

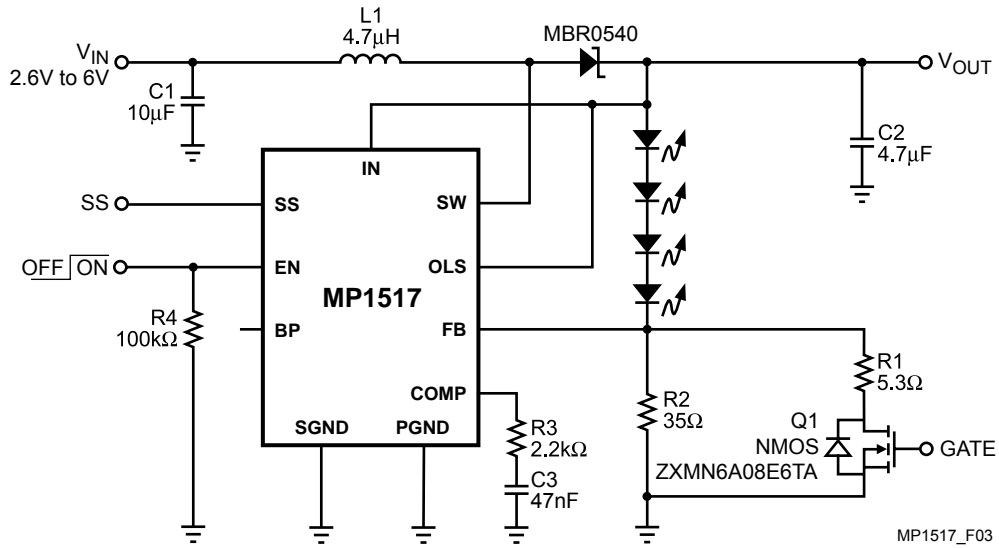

Figure 3—Flash Circuit Driving 4 White LEDs (150mA Flash Current)

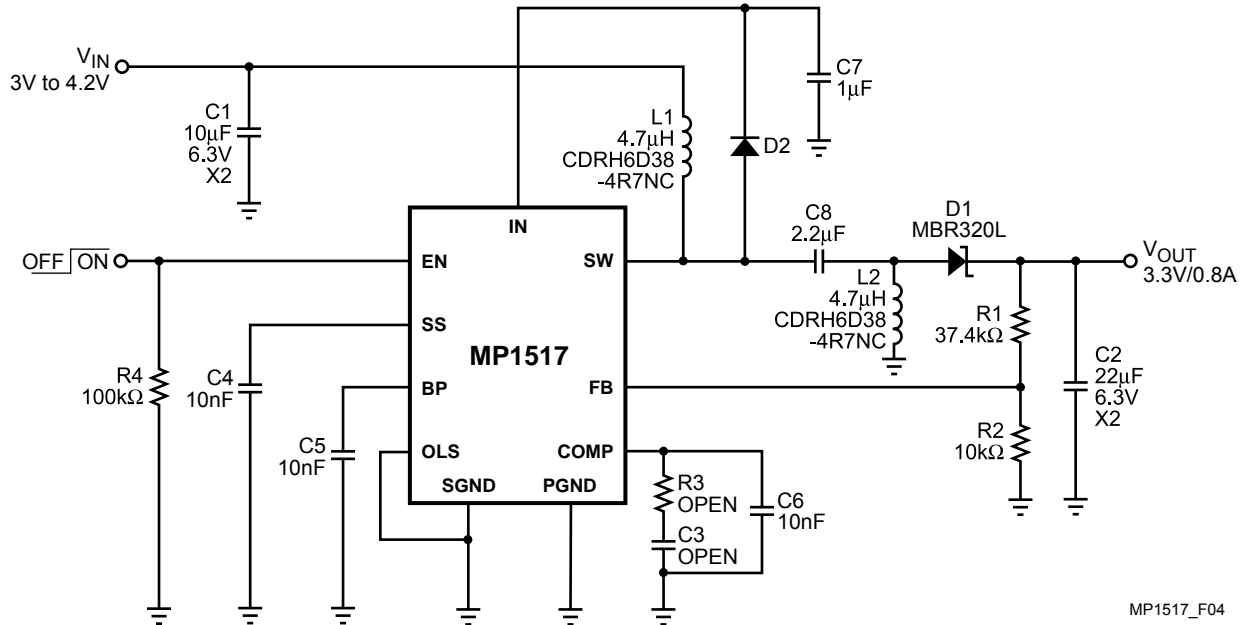

Figure 4—Typical SEPIC Application Circuit

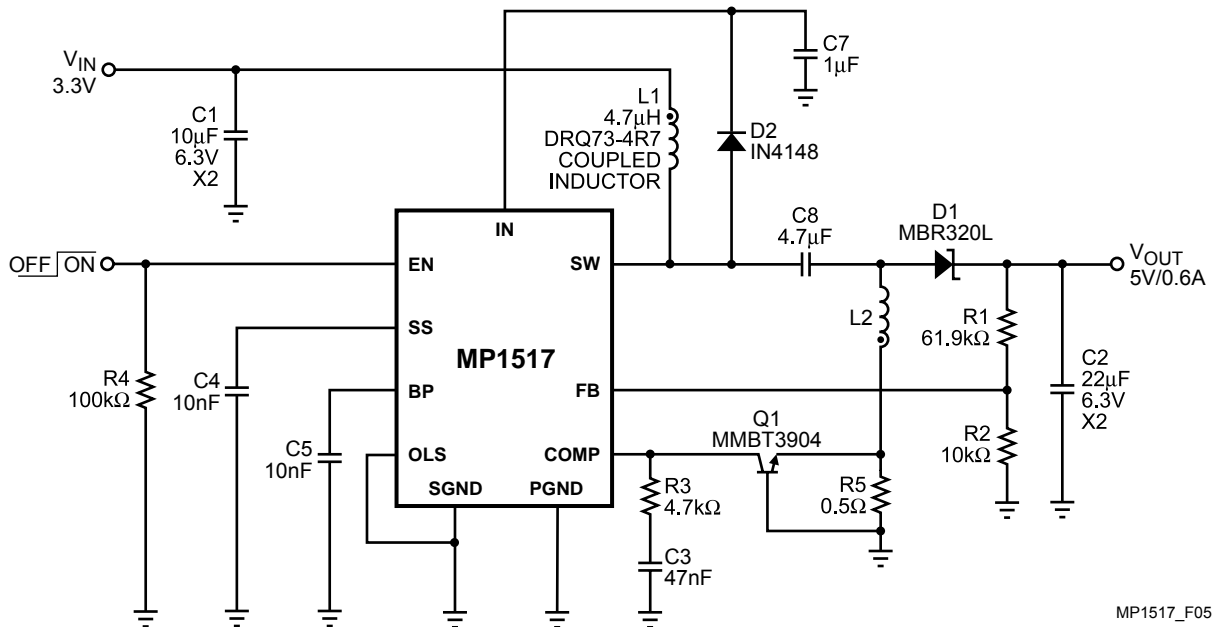

Figure 5—3.3V to 5V @ 600mA SEPIC Application Circuit

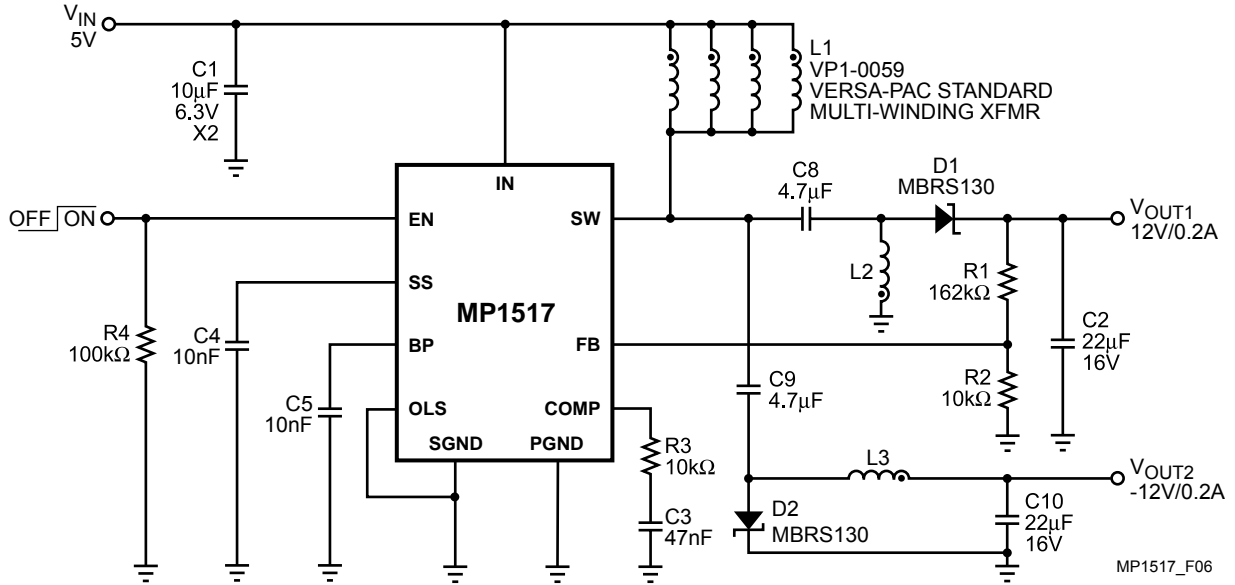
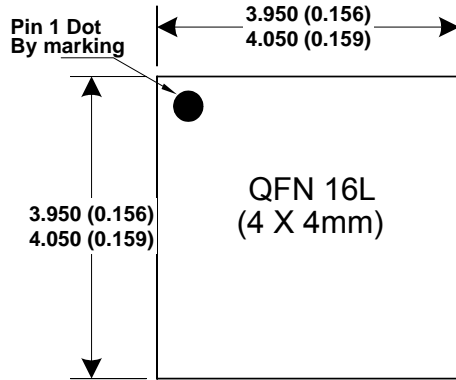

Figure 6— $\pm$ 12V SEPIC Application Circuit

MP1517\_F06

PACKAGE INFORMATION

QFN16-4 (4mm x 4mm)



Top View

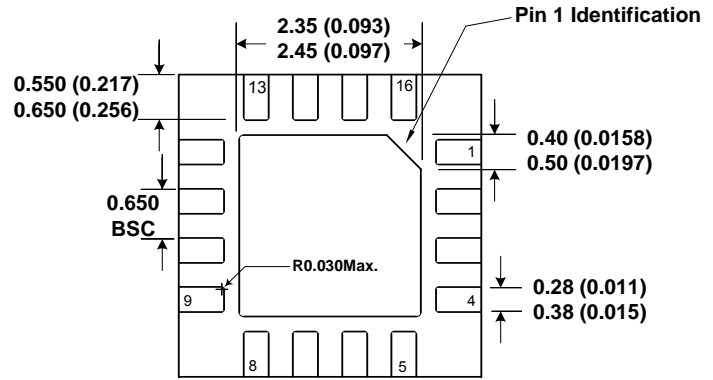

Bottom View

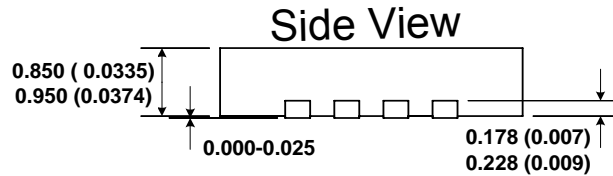

Side View

**NOTICE:** The information in this document is subject to change without notice. Please contact MPS for current specifications. Users should warrant and guarantee that third party Intellectual Property rights are not infringed upon when integrating MPS products into any application. MPS will not assume any legal responsibility for any said applications.