

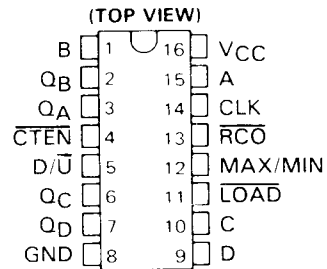

**MOTOROLA**

**TYPES SN54ALS190, SN54ALS191,  
SN74ALS190, SN74ALS191  
SYNCHRONOUS 4-BIT UP/DOWN DECADE AND BINARY COUNTERS**

- Single Down/Up Count Control Line
- Look-Ahead Circuitry Enhances Speed of Cascaded Counters
- Fully Synchronous in Count Modes
- Asynchronously Presetable with Load Control



000222 4/30  
VSS 17021 263

**descriptions**

The 'ALS190 and 'ALS191 are synchronous, reversible up/down counters. The 'ALS190 is a 4-bit decade counter and the 'ALS191 is a 4-bit binary counter. Synchronous counting operation is provided by having all flip-flops clocked simultaneously so that the outputs change coincident with each other when so instructed by the steering logic. This mode of operation eliminates the output counting spikes normally associated with asynchronous (ripple clock) counters.

The outputs of the four flip-flops are triggered on a low-to-high-level transition of the clock input if the enable input ( $\overline{\text{CTEN}}$ ) is low. A high at  $\overline{\text{CTEN}}$  inhibits counting. The direction of the count is determined by the level of the down/up (D/ $\overline{\text{U}}$ ) input. When D/ $\overline{\text{U}}$  is low, the counter counts up and when D/ $\overline{\text{U}}$  is high, it counts down.

These counters feature a fully independent clock circuit. Changes at the control inputs ( $\overline{\text{CTEN}}$  and D/ $\overline{\text{U}}$ ) that will modify the operating mode have no effect on the contents of the counter until clocking occurs. The function of the counter will be dictated solely by the condition meeting the stable setup and hold times.

These counters are fully programmable; that is, the outputs may each be preset to either level by placing a low on the load input and entering the desired data at the data inputs. The output will change to agree with the data inputs independently of the level of the clock input. This feature allows the counters to be used as modulo-N dividers by simply modifying the count length with the preset inputs.

The CLK, D/ $\overline{\text{U}}$ , and LOAD inputs are buffered to lower the drive requirement, which significantly reduces the loading on, or current required by, clock drivers, etc., for long parallel words.

Two outputs have been made available to perform the cascading function: ripple clock and maximum/minimum count. The latter output produces a high-level output pulse with a duration approximately equal to one complete cycle of the clock while the count is zero (all outputs low) counting down or maximum (9 or 15) counting up. The ripple clock output produces a low-level output pulse under those same conditions but only while the clock input is low. The counters can be easily cascaded by feeding the ripple clock output to the enable input of the succeeding counter if parallel clocking is used, or to the clock input if parallel enabling is used. The maximum/minimum count output can be used to accomplish look-ahead for high-speed operation.

The SN54ALS190 and SN54ALS191 are characterized for operation over the full military temperature range of -55 °C to 125 °C. The SN74ALS190 and SN74ALS191 are characterized for operation from 0 °C to 70 °C.

J Suffix—Case 620-08 (Ceramic)  
N Suffix—Case 648-05 (Plastic)

Portions of this data sheet are reprinted with permission from the Texas Instruments 1983 ALS/AS Logic Circuits Data Book.

© MOTOROLA INC., 1983 DS9626

# TYPES SN54ALS190, SN74ALS190 SYNCHRONOUS 4-BIT UP/DOWN DECADE COUNTERS

'ALS190 logic symbol

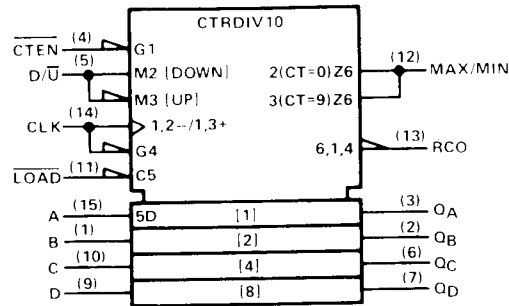

'ALS190 logic diagram (positive logic)

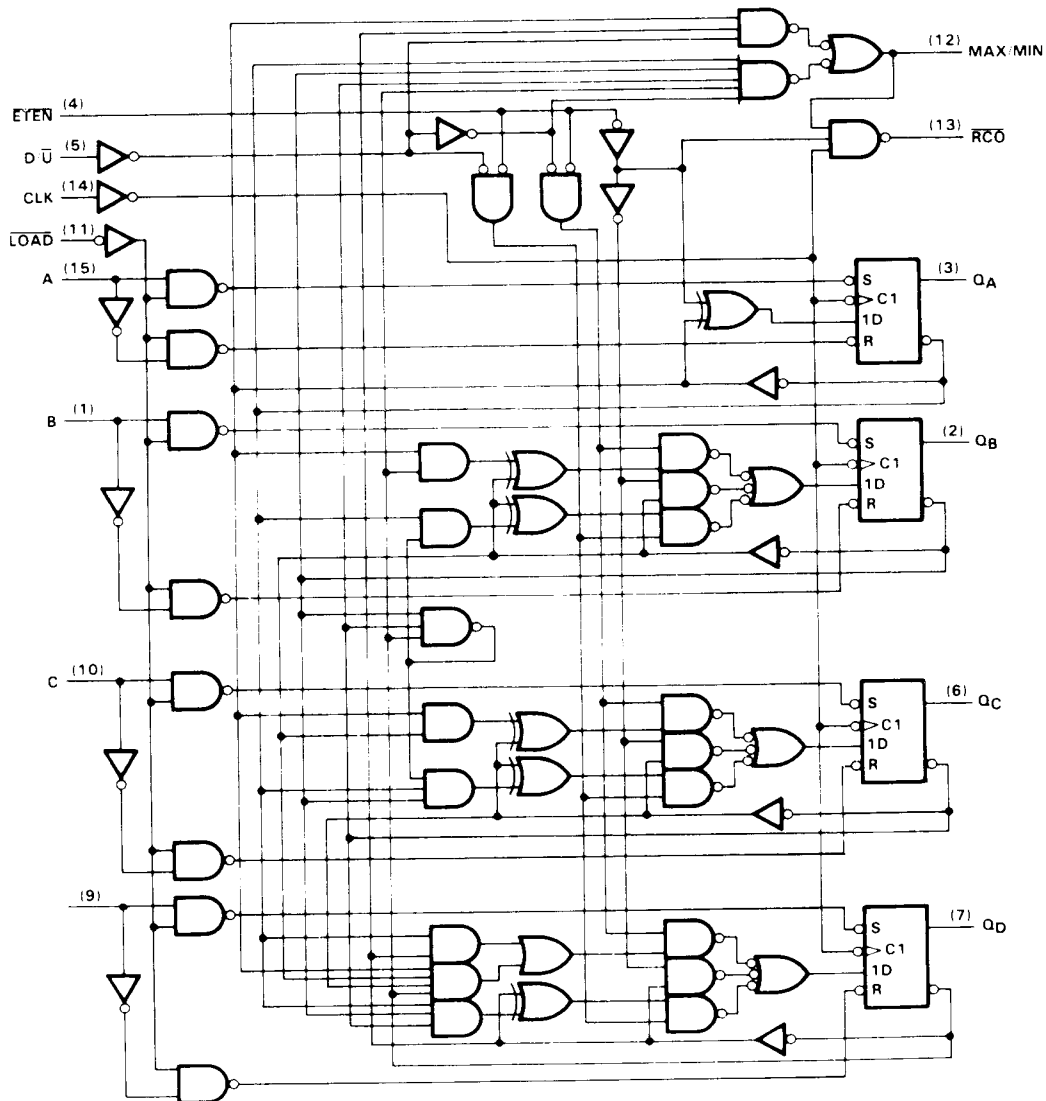

Pin numbers shown are for J and N packages.

# TYPES SN54ALS191, SN74ALS191 SYNCHRONOUS 4-BIT UP/DOWN BINARY COUNTERS

'ALS191 logic symbol

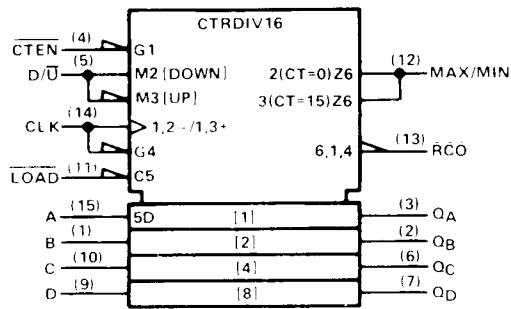

'ALS191 logic diagram (positive logic)

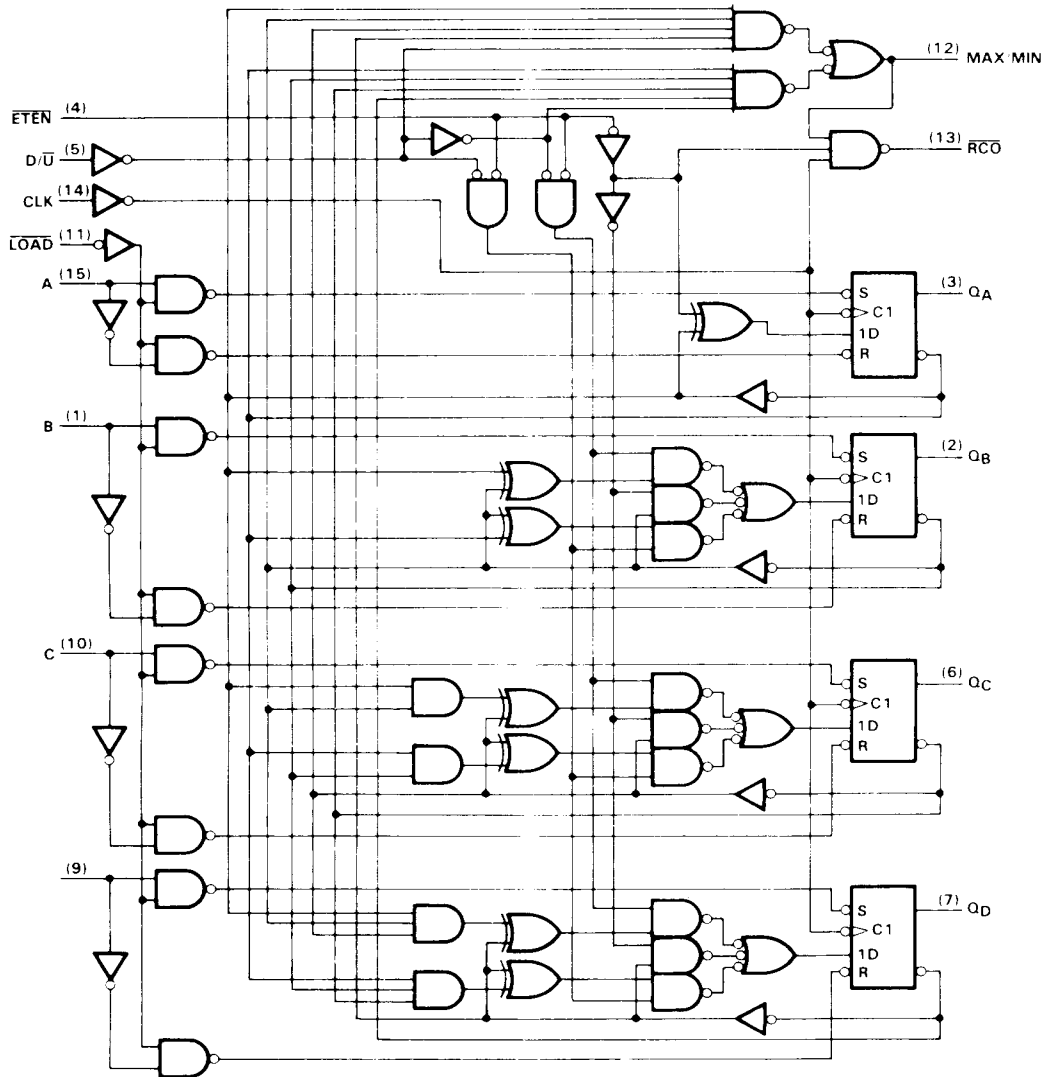

Pin numbers shown are for J and N packages.

# TYPES SN54ALS190, SN74ALS190 SYNCHRONOUS 4-BIT UP/DOWN DECADE COUNTERS

typical load, count, and inhibit sequences

'ALS190

Illustrated below is the following sequence:

1. Load (preset) to BCD seven.
2. Count up to eight, nine (maximum), zero, one, and two.
3. Inhibit.
4. Count down to one, zero (minimum), nine, eight, and seven.

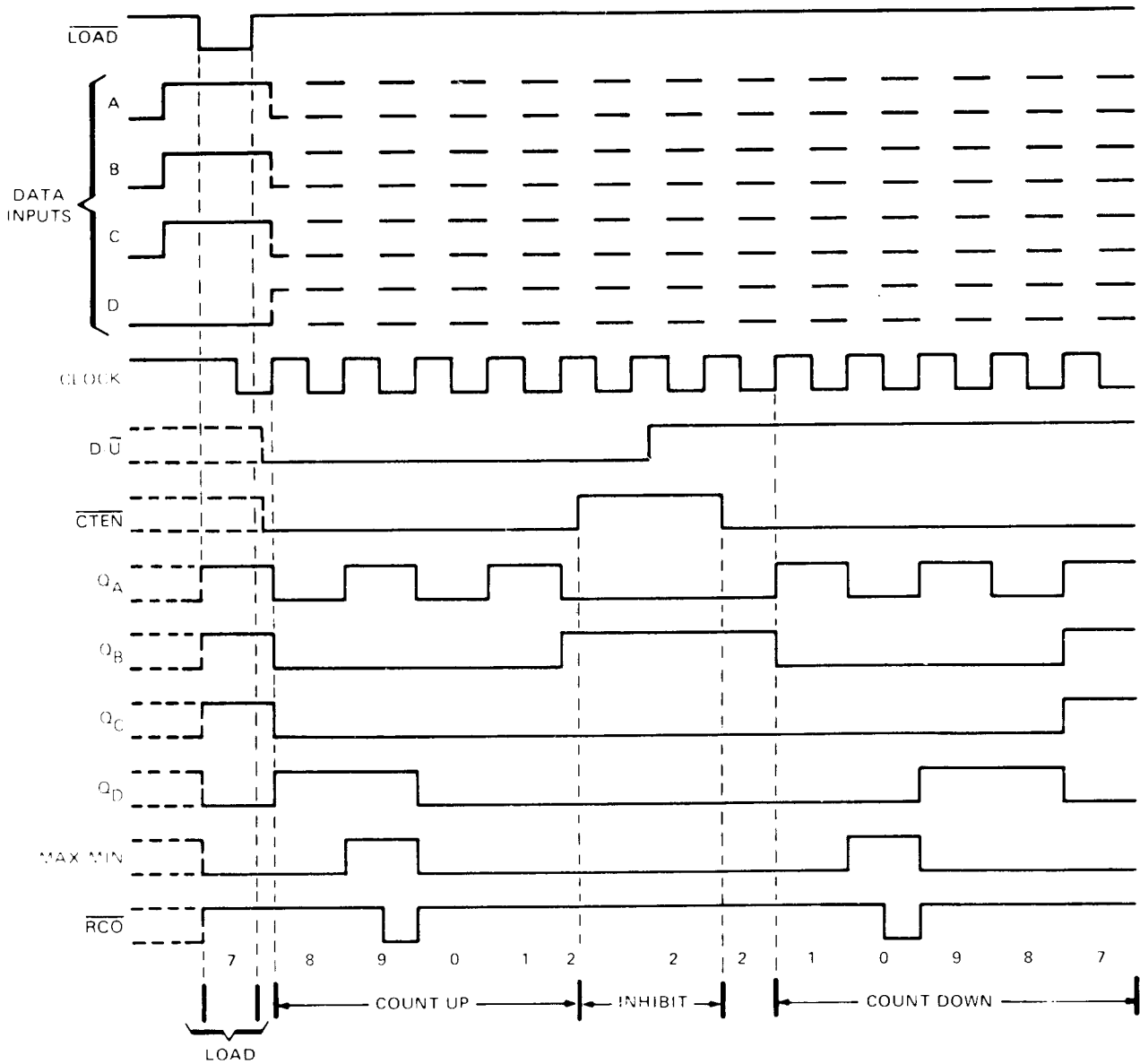

# TYPES SN54ALS191, SN74ALS191 SYNCHRONOUS 4-BIT UP/DOWN BINARY COUNTERS

typical load, count, and inhibit sequences

'ALS191

Illustrated below is the following sequence:

1. Load (preset) to binary thirteen.
2. Count up to fourteen, fifteen (maximum), zero, one, and two.
3. Inhibit.
4. Count down to one, zero (minimum), fifteen, fourteen, and thirteen.

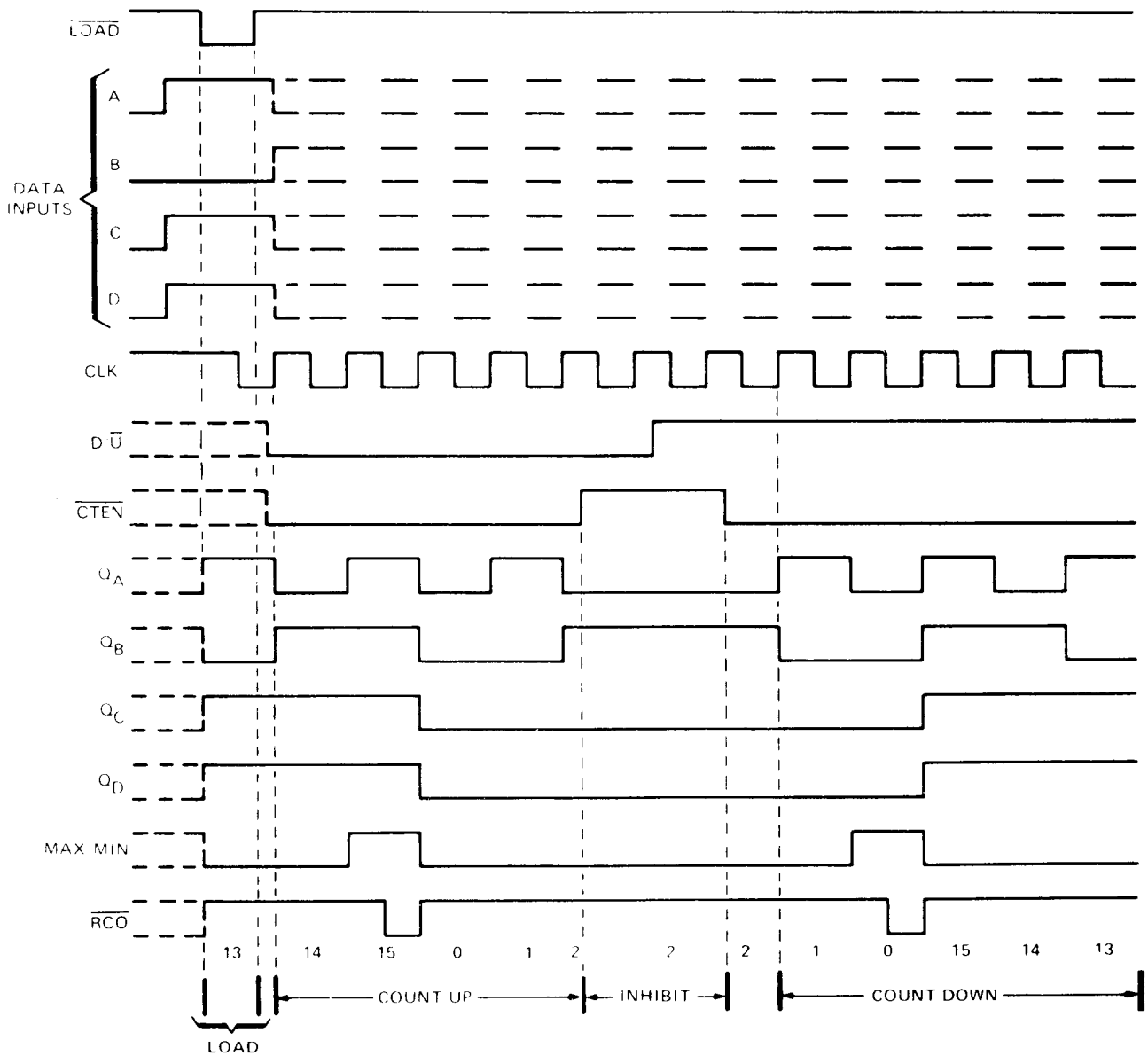

# TYPES SN54ALS190, SN54ALS191, SN74ALS190, SN74ALS191

## SYNCHRONOUS 4-BIT UP/DOWN DECADE AND BINARY COUNTERS

absolute maximum ratings over operating free-air temperature range (unless otherwise noted)

Supply voltage, $V_{CC}$ .....	7 V
Input voltage .....	7 V
Operating free-air temperature range: SN54ALS190, SN54ALS191 .....	-55 °C to 125 °C
SN74ALS190, SN74ALS191 .....	0 °C to 70 °C
Storage temperature range .....	-65 °C to 150 °C

recommended operating conditions

		SN54ALS190 SN54ALS191			SN74ALS190 SN74ALS191			UNIT
		MIN	NOM	MAX	MIN	NOM	MAX	
$V_{CC}$	Supply voltage	4.5	5	5.5	4.5	5	5.5	V
$V_{IH}$	High-level input voltage	2			2			V
$V_{IL}$	Low-level input voltage			0.8			0.8	V
$I_{OH}$	High-level output current			-0.4			-0.4	mA
$I_{OL}$	Low-level output current			4			8	mA
$f_{clock}$	Clock frequency	'ALS190		25	0		25	MHz
		'ALS191		25	0		25	
$t_w$	Pulse duration	CLK high	20		20			ns
		CLK low	20		20			
		$\overline{LOAD}$ low	25		25			
$t_{su}$	Setup time	Data before $\overline{LOAD}\dagger$	20		20			ns
		$\overline{CTEN}$ before CLK $\dagger$	20		20			
		D/ $\overline{U}$ before CLK $\dagger$	20		20			
		$\overline{LOAD}$ inactive before CLK $\dagger$	20		20			
$t_h$	Hold time	Data after $\overline{LOAD}\dagger$	0		0			ns
		$\overline{CTEN}$ after CLK $\dagger$	0		0			
		D/ $\overline{U}$ after CLK $\dagger$	0		0			
$T_A$	Operating free-air temperature	-55		125	0		70	°C

electrical characteristics over recommended operating free-air temperature range (unless otherwise noted)

PARAMETER	TEST CONDITIONS	SN54ALS190 SN54ALS191			SN74ALS190 SN74ALS191			UNIT
		MIN	TYP $\ddagger$	MAX	MIN	TYP $\ddagger$	MAX	
$V_{IK}$	$V_{CC} = 4.5 V, I_I = -18 mA$			-1.5			-1.5	V
$V_{OH}$	$V_{CC} = 4.5 V, I_{OH} = -0.4 mA$	2.5	3.4		2.5			V
	$V_{CC} = 4.75 V, I_{OH} = -0.4 mA$				2.7	3.4		
$V_{OL}$	$V_{CC} = 4.5 V, I_{OL} = 4 mA$		0.25	0.4		0.25	0.4	V
	$V_{CC} = 4.75 V, I_{OL} = 8 mA$					0.35	0.5	
$I_I$	$\overline{CTEN}$			0.1			0.1	mA
	All others			0.1			0.1	
$I_{IH}$	$\overline{CTEN}$			20			20	$\mu A$
	All others			20			20	
$I_{IL}$	$\overline{CTEN}$			-0.2			-0.2	mA
	All others			-0.1			-0.1	
$I_{OS}^*$	$V_{CC} = 5.5 V, V_O = GND$	-25		-150	-25		-150	mA
$I_{CC}$	$V_{CC} = 5.5 V, \text{All inputs at } 0 V$			17.5			17.5	mA

$\ddagger$ All typical values are at  $V_{CC} = 5 V, T_A = 25 ^\circ C$ .

\*The current produced by grounding the outputs is approximately twice that produced with 2.25 V on the outputs.

# TYPES SN54ALS190, SN54ALS191, SN74ALS190, SN74ALS191 SYNCHRONOUS 4-BIT UP/DOWN DECADE AND BINARY COUNTERS

## switching characteristics

PARAMETER	FROM (INPUT)	TO (OUTPUT)	$V_{CC} = 4.5 \text{ V to } 5.5 \text{ V},$ $C_L = 50 \text{ pF},$ $R_L = 500 \Omega,$ $T_A = \text{MIN to MAX}$				UNIT
			SN54ALS190 SN54ALS191		SN74ALS190 SN74ALS191		
			MIN	MAX	MIN	MAX	
$f_{max}$	ALS190		25		25		MHz
	ALS191		25		25		
$t_{PLH}$	$\overline{LOAD}$	Any Q	8	45	8	45	ns
$t_{PHL}$			8	35	8	35	
$t_{PLH}$	A, B, C, D	Any Q	4	28	4	26	ns
$t_{PHL}$			4	37	4	35	
$t_{PLH}$	CLK	$\overline{RCO}$	5	17	5	16	ns
$t_{PHL}$			5	15	5	14	
$t_{PLH}$	CLK	Any Q	3	25	3	25	ns
$t_{PHL}$			3	28	3	28	
$t_{PLH}$	CLK	MAX MIN	8	35	8	35	ns
$t_{PHL}$			8	25	8	20	
$t_{PLH}$	$D \bar{U}$	$\overline{RCO}$	15	44	15	40	ns
$t_{PHL}$			10	34	10	32	
$t_{PLH}$	$D \bar{U}$	MAX MIN	8	28	8	26	ns
$t_{PHL}$			8	28	8	26	
$t_{PLH}$	$\overline{CTEN}$	$\overline{RCO}$	4	17	4	17	ns
$t_{PHL}$			4	16	4	16	

Motorola reserves the right to make changes to any products herein to improve reliability, function or design. Motorola does not assume any liability arising out of the application or use of any product or circuit described herein, neither does it convey any license under its patent rights nor the rights of others.