



STTS2002

2.3 V memory module temperature sensor with a 2 Kb SPD EEPROM

Data brief

Features

- STTS2002 is a 2.3 V memory module temperature sensor with 2 Kb SPD EEPROM forward compatible with JEDEC standard TSE 2002a2 and backward compatible with STTS424E02
- Operating temperature range:
 - $-40\text{ }^{\circ}\text{C}$ to $+125\text{ }^{\circ}\text{C}$
- Single supply voltage: 2.3 V to 3.6 V
- 2 mm x 3 mm TDFN8, height: 0.80 mm (max)^(a)
- RoHS compliant, halogen-free

Temperature sensor

- Temperature sensor resolution: programmable (9-12 bits)
 $0.25\text{ }^{\circ}\text{C}$ (typ)/LSB - (10-bit) default
- Temperature sensor accuracy (max):
 - $\pm 1\text{ }^{\circ}\text{C}$ from $+75\text{ }^{\circ}\text{C}$ to $+95\text{ }^{\circ}\text{C}$
 - $\pm 2\text{ }^{\circ}\text{C}$ from $+40\text{ }^{\circ}\text{C}$ to $+125\text{ }^{\circ}\text{C}$
 - $\pm 3\text{ }^{\circ}\text{C}$ from $-40\text{ }^{\circ}\text{C}$ to $+125\text{ }^{\circ}\text{C}$
- ADC conversion time: 125 ms (max) at default resolution (10-bit)
- Typical operating supply current: 160 μA (EEPROM standby)
- Temperature hysteresis selectable set points from: 0, 1.5, 3, 6.0 $^{\circ}\text{C}$
- Supports SMBus timeout 25 ms - 35 ms

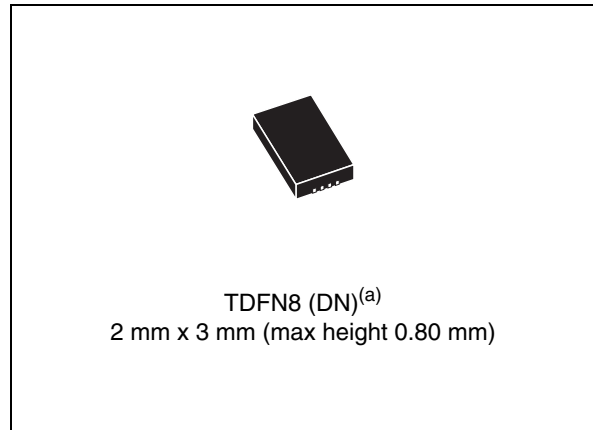

2 Kb SPD EEPROM

- Functionality identical to ST's M34E02 SPD EEPROM
- Permanent and reversible software data protection for the lower 128 bytes
- Byte and page write (up to 16 bytes)
- Self-time WRITE cycle (5 ms, max)
- Automatic address incrementing

Two-wire bus

- Two-wire SMBus/I²C - compatible serial interface
- Supports up to 400 kHz transfer rate
- Does not initiate clock stretching

a. Compliant to JEDEC MO-229, WCED-3

1 Description

The STTS2002 is targeted for DIMM modules in mobile personal computing platforms (laptops), servers and other industrial applications. The thermal sensor (TS) in the STTS2002 is compliant with the JEDEC specification TSE2002a2, which defines memory module thermal sensors requirements for mobile platforms. The 2 Kbit serial presence detect (SPD) I²C-compatible electrically erasable programmable memory (EEPROM) in the STTS2002 is organized as 256 x8 bits and is functionally identical to the industry standard M34E02.

The TS-SPD EEPROM combination provides space as well as cost savings for mobile and server platform dual inline memory modules (DIMM) manufacturers, as it is packaged in the compact 2 mm x 3 mm 8-lead TDFN package with a thinner maximum height of 0.80 mm. The DN package is compliant to JEDEC MO-229, variation WCED-3.

The digital temperature sensor has a programmable 9-12 bit analog-to-digital converter (ADC) which monitors and digitizes the temperature to a resolution of up to 0.0625 °C. The default resolution is 0.25 °C/LSB (10-bit). The typical accuracies over these temperature ranges are:

- ±2 °C over the full temperature measurement range of –40 °C to 125 °C
- ±1 °C in the +40 °C to +125 °C active temperature range, and
- ±0.5 °C in the +75 °C to +95 °C monitor temperature range

The temperature sensor in the STTS2002 is specified for operating at supply voltages from 2.3 V to 3.6 V. Operating at 3.3 V, the typical supply current is 160 µA (includes SMBus communication current).

The on-board sigma delta ADC converts the measured temperature to a digital value that is calibrated in °C. For Fahrenheit applications, a lookup table or conversion routine is required. The STTS2002 is factory-calibrated and requires no external components to measure temperature.

The digital temperature sensor component has user-programmable registers that provide the capabilities for DIMM temperature-sensing applications. The open drain event output pin is active when the monitoring temperature exceeds a programmable limit, or it falls above or below an alarm window. The user has the option to set the event output as a critical temperature output. This pin can be configured to operate in either a comparator mode for thermostat operation or in interrupt mode.

The 2 Kbit serial EEPROM memory in the STTS2002 has the ability to permanently lock the data in its first half (upper) 128 bytes (locations 00h to 7Fh). This feature has been designed specifically for use in DRAM DIMMs with SPD. All of the information concerning the DRAM module configuration (e.g. access speed, size, and organization) can be kept write protected in the first half of the memory. The second half (lower) 128 bytes of the memory can be write protected using two different software write protection mechanisms.

By sending the device a specific sequence, the first 128 bytes of the memory become write protected: permanently or resettable. In the STTS2002 the write protection of the memory array is dependent on whether the software protection has been set.

Figure 1. Logic diagram

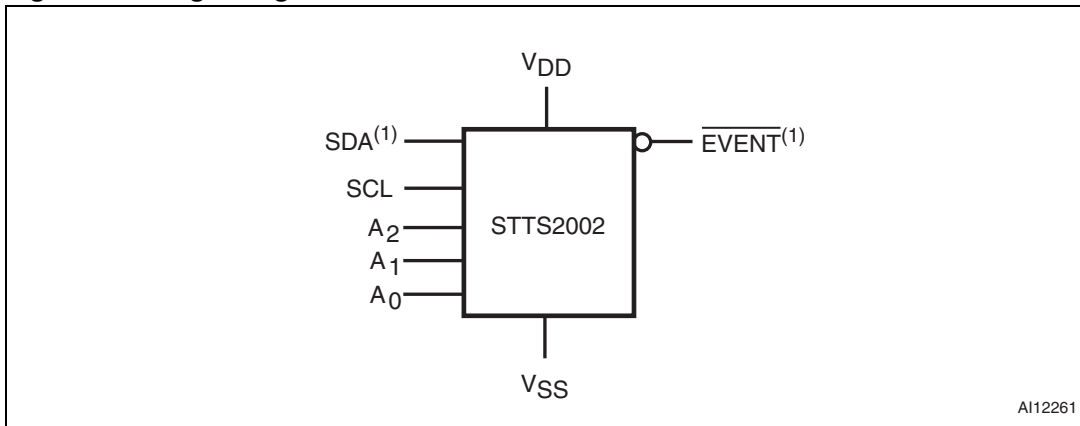

1. SDA and $\overline{\text{EVENT}}$ are open drain.

Table 1. Signal names

Pin	Symbol	Description	Direction
1	A0	Serial bus address selection pin. Can be tied to V_{SS} or V_{DD} .	Input
2	A1	Serial bus address selection pin. Can be tied to V_{SS} or V_{DD} .	Input
3	A2	Serial bus address selection pin. Can be tied to V_{SS} or V_{DD} .	Input
4	V_{SS}	Supply ground	
5	$\text{SDA}^{(1)}$	Serial data	Input/output
6	SCL	Serial clock	Input
7	$\overline{\text{EVENT}}^{(1)}$	Event output pin. Open drain and active-low.	Output
8	V_{DD}	Supply power (2.3 V to 3.6 V)	

1. SDA and $\overline{\text{EVENT}}$ are open drain.

Figure 2. TDFN8 connections (top view)

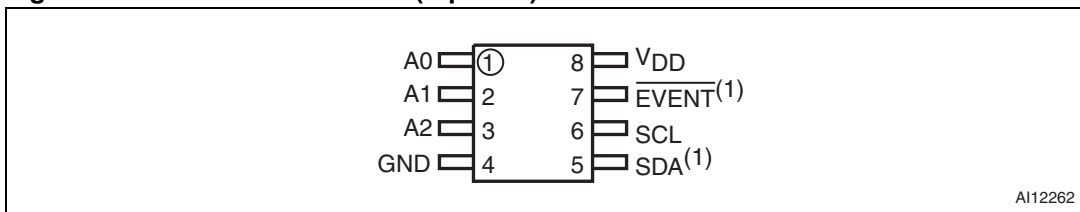

1. SDA and $\overline{\text{EVENT}}$ are open drain.

Figure 3. Block diagram

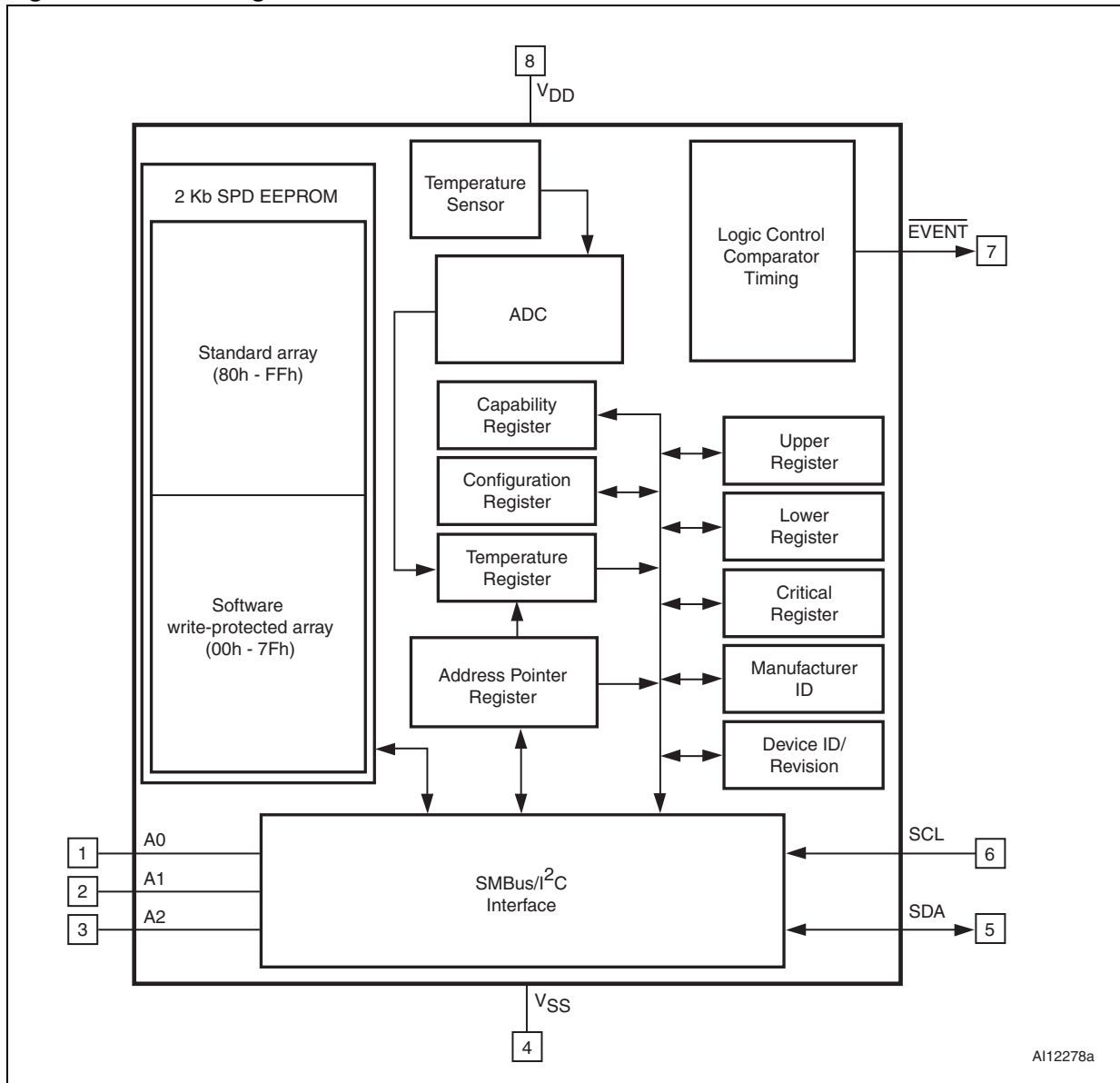

2 Temperature sensor registers

The temperature sensor component is comprised of various user-programmable registers. These registers are required to write their corresponding addresses to the pointer register. They can be accessed by writing to their respective addresses (see [Table 2](#)). Pointer register bits 7 - 4 must always be written to '0'. This must be maintained, as not setting these bits to '0' may keep the device from performing to specifications.

The main registers include the :

- Capability register (read-only)
- Configuration register (read/write)
- Temperature register (read-only)
- Temperature trip point registers (read/write), including
 - Alarm temperature upper boundary
 - Alarm temperature lower boundary and
 - Critical temperature
- Manufacturer's ID register (read-only)
- Device ID and device revision ID register (read-only)
- Temperature resolution register (TRES) (read/write)

Table 2. Temperature sensor registers summary

Address (hex)	Register name		Power-on default
Not applicable	Address pointer		Undefined
00	Capability	B-grade	0x006F
01	Configuration		0x0000
02	Alarm temperature upper boundary trip		0x0000
03	Alarm temperature lower boundary trip		0x0000
04	Critical temperature trip		0x0000
05	Temperature		Undefined
06	Manufacturer's ID		0x104A
07	Device ID/revision		0x0300
08	Temperature resolution register		0x0001

3 Part numbering

Table 3. Ordering information scheme

Example:	STTS2002	B	2	DN	3	F
Device type						
STTS2002						
Accuracy grade						
B: Maximum accuracy 75 °C to 95 °C = ± 1 °C						
Voltage (minimum)						
2 = 2.3 V - 3.6 V part						
Package						
DN = TDFN8 (0.80 mm max height)						
Temperature						
3 = -40 °C to 125 °C						
Shipping method						
F = ECOPACK® package, tape & reel packing						
E = ECOPACK® package, tube packing						

For other options, or for more information on any aspect of this device, please contact the ST sales office nearest you.

4 Package marking information

Figure 4. DN package topside marking information (TDFN8)

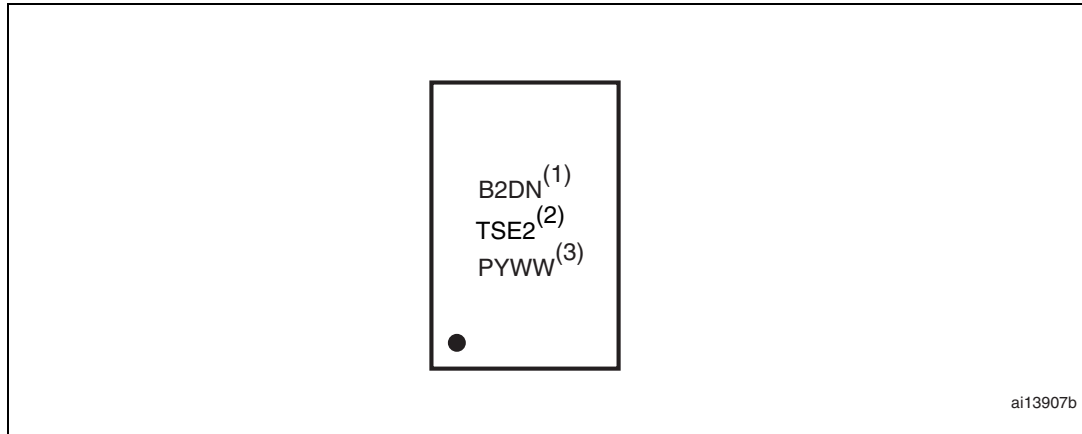

1. Temperature grade and package
B = B-grade, stacked
2 = Minimum operating voltage of 2.3 V
DN = 0.80 mm TDFN package
2. Device name
TSE2 = STTS2002
3. Traceability codes
P = 2nd digit of plant code
Y = Year
WW = Work Week

5 Revision history

Table 4. Document revision history

Date	Revision	Changes
03-Mar-2010	1	Initial release.

Please Read Carefully:

Information in this document is provided solely in connection with ST products. STMicroelectronics NV and its subsidiaries ("ST") reserve the right to make changes, corrections, modifications or improvements, to this document, and the products and services described herein at any time, without notice.

All ST products are sold pursuant to ST's terms and conditions of sale.

Purchasers are solely responsible for the choice, selection and use of the ST products and services described herein, and ST assumes no liability whatsoever relating to the choice, selection or use of the ST products and services described herein.

No license, express or implied, by estoppel or otherwise, to any intellectual property rights is granted under this document. If any part of this document refers to any third party products or services it shall not be deemed a license grant by ST for the use of such third party products or services, or any intellectual property contained therein or considered as a warranty covering the use in any manner whatsoever of such third party products or services or any intellectual property contained therein.

UNLESS OTHERWISE SET FORTH IN ST'S TERMS AND CONDITIONS OF SALE ST DISCLAIMS ANY EXPRESS OR IMPLIED WARRANTY WITH RESPECT TO THE USE AND/OR SALE OF ST PRODUCTS INCLUDING WITHOUT LIMITATION IMPLIED WARRANTIES OF MERCHANTABILITY, FITNESS FOR A PARTICULAR PURPOSE (AND THEIR EQUIVALENTS UNDER THE LAWS OF ANY JURISDICTION), OR INFRINGEMENT OF ANY PATENT, COPYRIGHT OR OTHER INTELLECTUAL PROPERTY RIGHT.

UNLESS EXPRESSLY APPROVED IN WRITING BY AN AUTHORIZED ST REPRESENTATIVE, ST PRODUCTS ARE NOT RECOMMENDED, AUTHORIZED OR WARRANTED FOR USE IN MILITARY, AIR CRAFT, SPACE, LIFE SAVING, OR LIFE SUSTAINING APPLICATIONS, NOR IN PRODUCTS OR SYSTEMS WHERE FAILURE OR MALFUNCTION MAY RESULT IN PERSONAL INJURY, DEATH, OR SEVERE PROPERTY OR ENVIRONMENTAL DAMAGE. ST PRODUCTS WHICH ARE NOT SPECIFIED AS "AUTOMOTIVE GRADE" MAY ONLY BE USED IN AUTOMOTIVE APPLICATIONS AT USER'S OWN RISK.

Resale of ST products with provisions different from the statements and/or technical features set forth in this document shall immediately void any warranty granted by ST for the ST product or service described herein and shall not create or extend in any manner whatsoever, any liability of ST.

ST and the ST logo are trademarks or registered trademarks of ST in various countries.

Information in this document supersedes and replaces all information previously supplied.

The ST logo is a registered trademark of STMicroelectronics. All other names are the property of their respective owners.

© 2010 STMicroelectronics - All rights reserved

STMicroelectronics group of companies

Australia - Belgium - Brazil - Canada - China - Czech Republic - Finland - France - Germany - Hong Kong - India - Israel - Italy - Japan - Malaysia - Malta - Morocco - Philippines - Singapore - Spain - Sweden - Switzerland - United Kingdom - United States of America

www.st.com

