

**22W FRONT REAR OR BRIDGE FULLY PROTECTED
CAR RADIO AMPLIFIER**

SGS-THOMSON

30E D

- HIGH OUTPUT POWER
- POP FREE SWITCHING
- SHORT CIRCUIT PROTECTIONS: R_L SHORT - OUT TO GROUND - OUT TO V_S
- MUTING μP COMPATIBLE
- VERY LOW CONSUMPTION STANDBY
- PROGRAMMABLE TURN ON DELAY
- LOW DISTORTION AND LOW NOISE
- DIFFERENTIAL INPUT

Other Protections :

- LOAD DUMP VOLTAGE SURGE
- LOUDSPEAKER DC CURRENT
- VERY INDUCTIVE LOAD
- OVERRATING TEMPERATURE
- OPEN GROUND

The TDA7255 a class B dual fully protected power amplifier designed for car radio applications. The device can be switched from Front-Rear to Bridge configuration by changing only the loudspeaker connection. An input fader for Front-Rear control is available. A high current capability allows to drive low impedance loads (up to 1.6Ω).

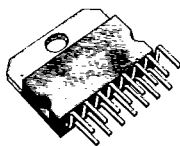

Multiwatt-15

ORDER CODE : TDA7255

BLOCK DIAGRAM

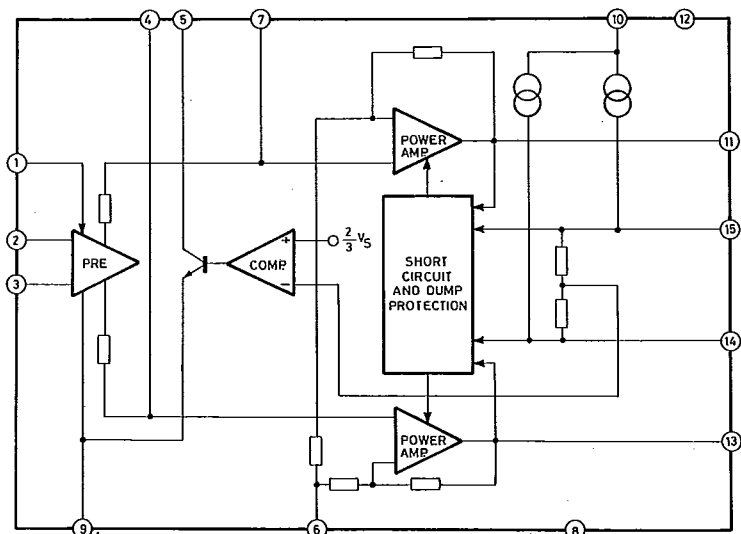

5-9189

ABSOLUTE MAXIMUM RATINGS

V_s	Operating supply voltage	18	V
V_s	DC supply voltage	28	V
V_s	Peak supply voltage (for 50ms)	40	V
I_o	Output peak current (non repetitive $t = 0.1\text{ms}$)	4.5	A
I_o	Output peak current (repetitive $f \geq 10\text{Hz}$)	4	A
P_{tot}	Power dissipation at $T_{\text{case}} = 60^\circ\text{C}$	30	W
T_{stg}, T_j	Storage and junction temperature	-40 to 150	$^\circ\text{C}$

CONNECTION DIAGRAM

(Top view)

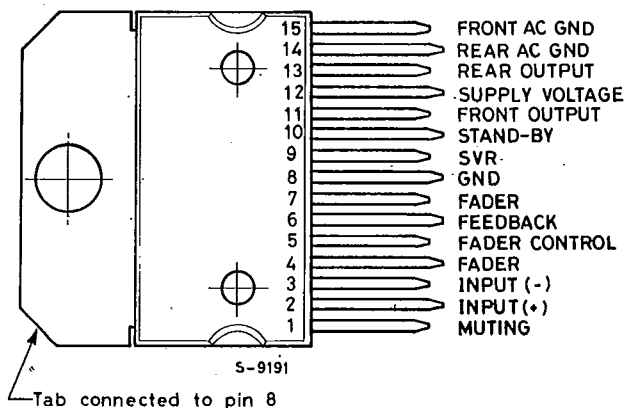

THERMAL DATA

$R_{\text{th J-case}}$	Thermal resistance junction-case	max	3	$^\circ\text{C/W}$
$R_{\text{th J-amb}}$	Thermal resistance junction-ambient	max	40	$^\circ\text{C/W}$

SGS-THOMSON

30E D

ELECTRICAL CHARACTERISTICS ($V_s = 14.4V$, $R_L = 4\Omega$, $f = 1KHz$, $T_{amb} = 25^\circ C$ unless otherwise specified)

Parameter	Test Conditions	Min.	Typ.	Max.	Unit
V_s Supply voltage		8		18	V
I_d Total quiescent drain current			80		mA
R_i Input resistance			70		K Ω
V_i Input saturation voltage		300			mV
T_j Thermal shut down junction temperature			145		$^\circ C$

FRONT REAR APPLICATIONS (Fig. 2)

P_o Output power	THD = 10% $R_L = 4\Omega$ $R_L = 2\Omega$ $R_L = 1.6\Omega$	5.5	6.5 11 12.5		W W W
d Distortion	$P_o = 0.1W$ to 4W		0.05	0.5	%
G_v Voltage gain			28		dB
e_N Input noise voltage	$R_G = 10K\Omega$		2.5(**) 2 (*)		μV μV
SVR Supply voltage rejection	$R_G = 100K\Omega$ $V_r = 1V$ $f = 300Hz$	36	45		dB
CMR Common mode rejection			55		dB
η Efficiency	$P_o = 6.5W + 6.5W$		70		%

BRIDGE APPLICATION (Fig. 1)

V_{os} Output offset voltage				250	mV
P_o Output power	THD = 10% $R_L = 4\Omega$ $R_L = 3.2\Omega$	18	22 25		W W
d Distortion	$P_o = 0.1W$ to 2W		0.05		%
G_v Voltage gain (C_L)			36		dB
e_N Total input noise voltage	$R_G = 10K\Omega$		2.5(**) 2.0 (*)	10	μV μV
η Efficiency	$P_o = 20W$		66		%
SVR Supply voltage rejection	$R_G = 10K\Omega$, $V_r = 1V$, $f = 300Hz$	45	58		dB

MUTING AND STAND-BY FUNCTIONS

Muting attenuation	$V_{ref} = 1W$ $f = 100Hz$ to 10KHz	60			dB
Muting-on threshold voltage	Pin. 1	2.4			V
Muting-off threshold voltage	Pin. 1			0.8	V
Stand-by attenuation	$V_{ref} = 1V$ $f = 100Hz$ to 10KHz	60			dB
Stand-by quiescent drain current				100	μA

(**) B = 22Hz to 22KHz

(*) B = curve A

Fig. 1 - Test and application circuit (Bridge amplifier)

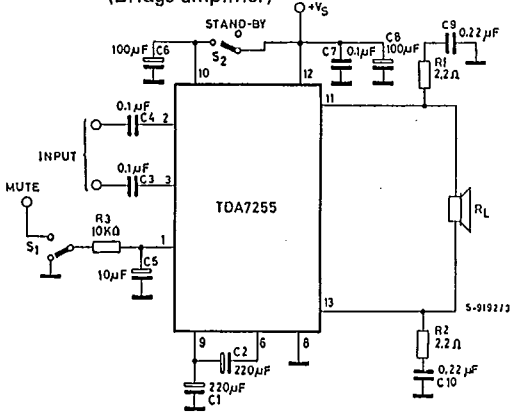
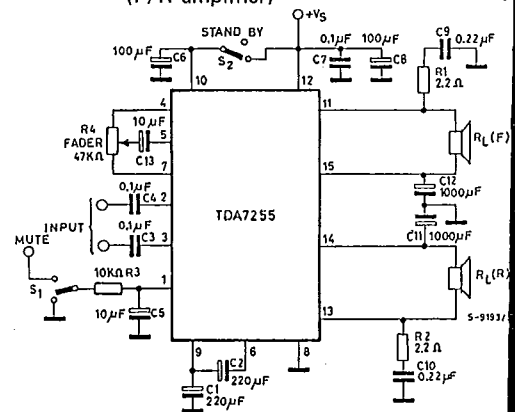
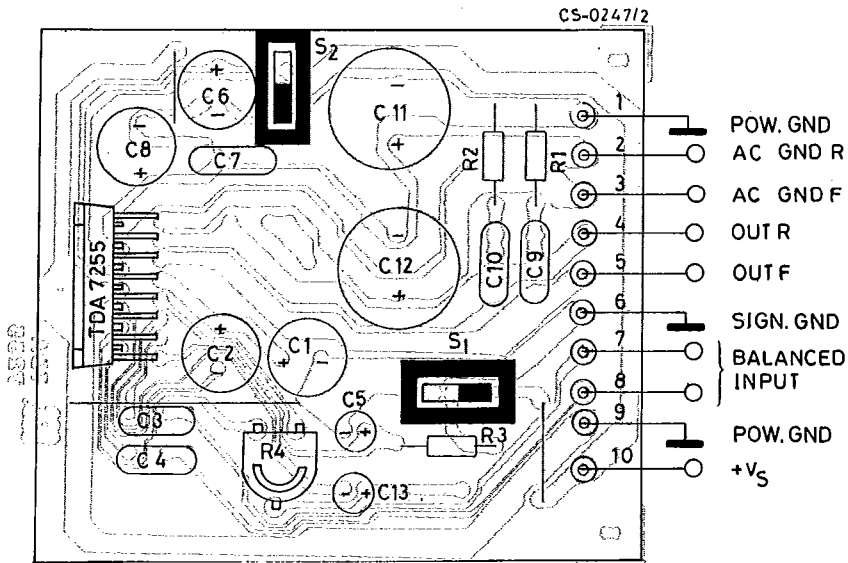

Fig. 2 - Test and application circuit (F/R amplifier)



- Two high impedance inputs available for balanced or unbalanced operation.
- The fader function is automatically inserted in front/rear configuration and allows the distribution of the power between the front and the rear. An external potentiometer must be connected between pins 4 and 7 with the control terminal connected to pin 5 through a decoupling capacitor. In bridge applications the pins 4-5-7 must be left open.
- Turn on delay. The output stages are muted during the turn on transient and start rising after the charge of the capacitor connected between pin 9 and ground. The capacitor also avoids pops during bridge F/R switching.

Fig. 3 - P.C. board and component layout of the circuits of Fig. 1 and 2 (1 : 1 scale)



S G S-THOMSON

30E D

FRONT/REAR CHARACTERISTICS

Fig. 4 - Quiescent drain current vs. supply voltage

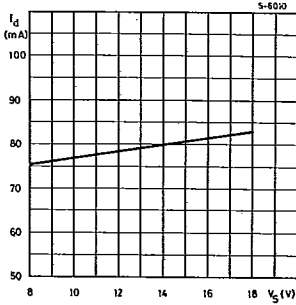

Fig. 5 - Quiescent output voltage vs. supply voltage

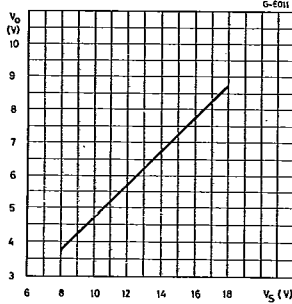

Fig. 6 - Output power vs. supply voltage

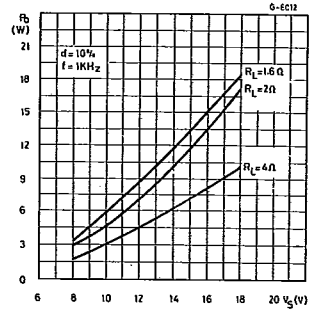

Fig. 7 - Distortion vs. frequency

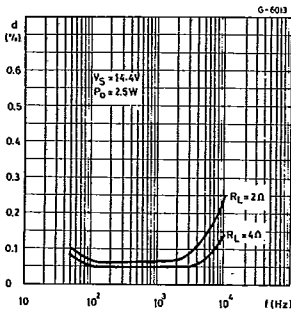

Fig. 8 - Supply voltage rejection vs. capacitor values (C2)

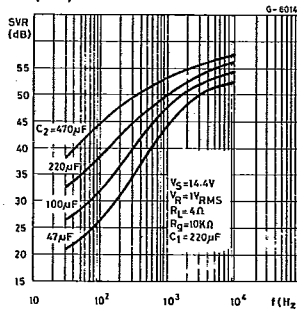

Fig. 9 - Supply voltage rejection vs. capacitor values (C1)

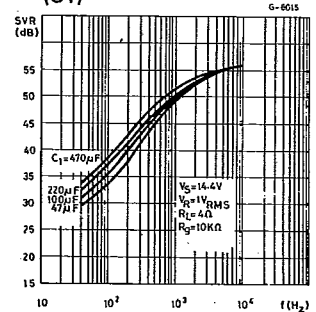

Fig. 10 - Output signal vs. fader control position

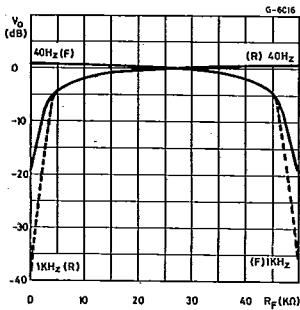

Fig. 11 - Power dissipation and efficiency vs. output power

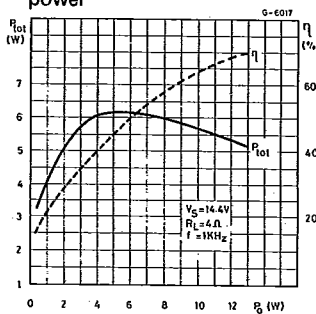
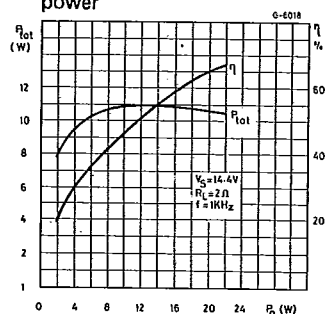

Fig. 12 - Power dissipation and efficiency vs. output power



S G S-THOMSON
BRIDGE CHARACTERISTICS

30E D

Fig. 13 -- Output power vs. supply voltage

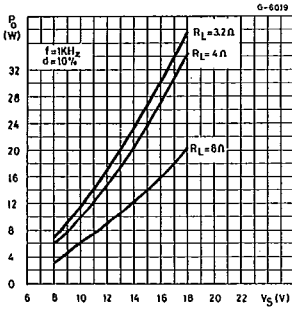

Fig. 14 - Distortion vs. frequency

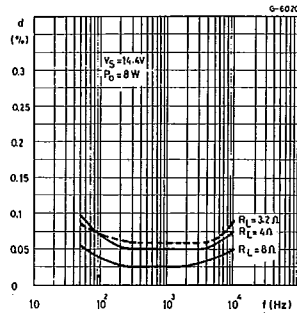

Fig. 15 - Supply voltage rejection vs. frequency

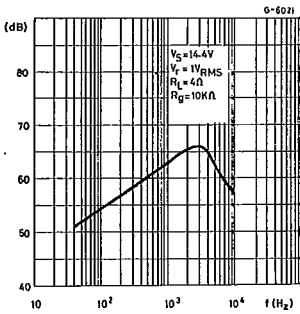

Fig. 16 - Power dissipation and efficiency vs. output power

