

## 6 + 6W STEREO AMPLIFIER WITH MUTING

### 1 FEATURES

- WIDE SUPPLY VOLTAGE RANGE
- HIGH OUTPUT POWER  
6+6W @  $V_S=20V$ ,  $R_L = 8\Omega$ , THD=10%
- MUTE FACILITY (POP FREE) WITH LOW CONSUMPTION
- AC SHORT CIRCUIT PROTECTION
- THERMAL OVERLOAD PROTECTION

### 2 DESCRIPTION

The TDA7263L is class AB dual audio power amplifier assembled in Single IN Line 10 pins package, specially designed for high quality sound application as HI-FI music centers and stereo TV sets.

Figure 1. Package

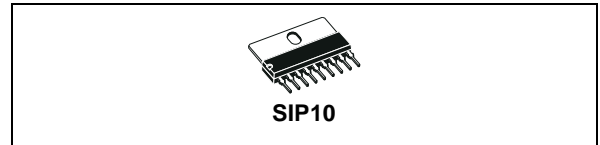
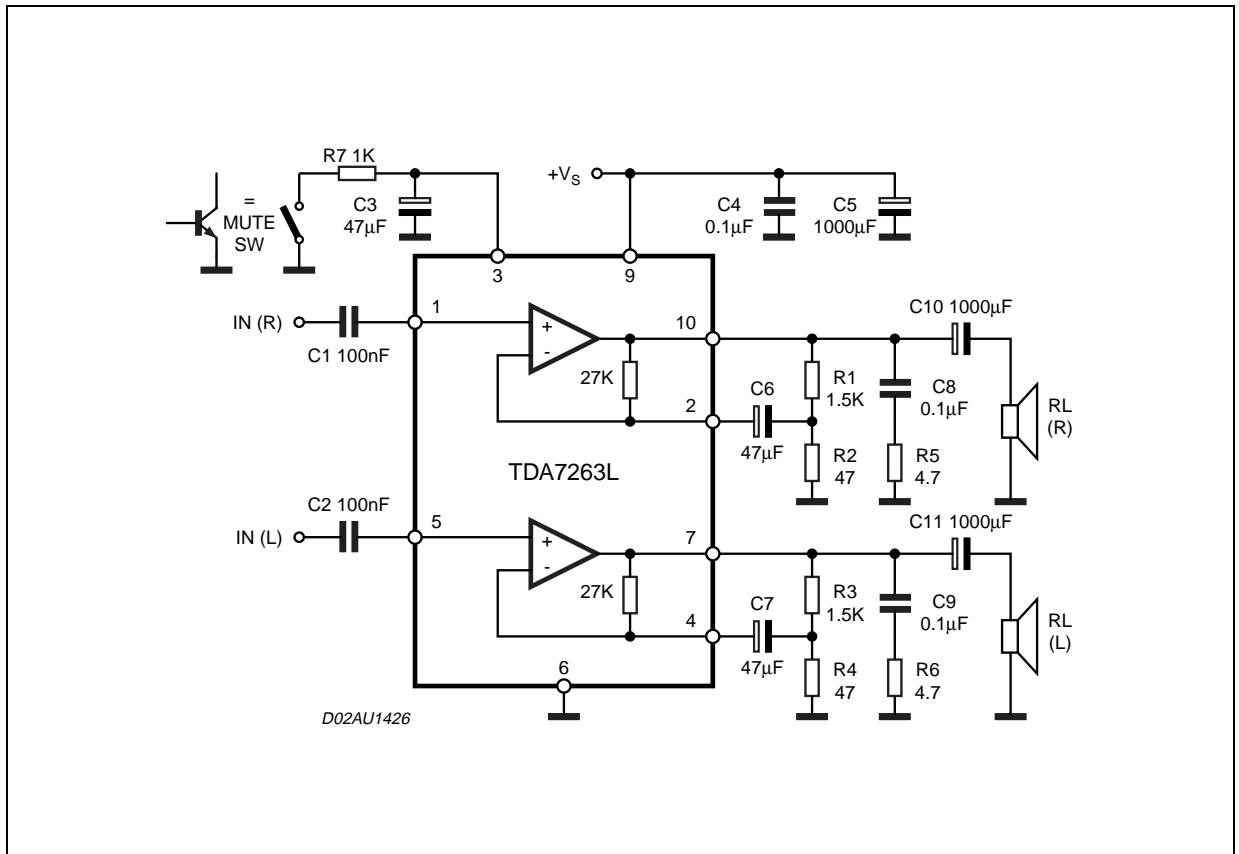


Table 1. Order Codes

Part Number	Package
TDA7263L	SIP10

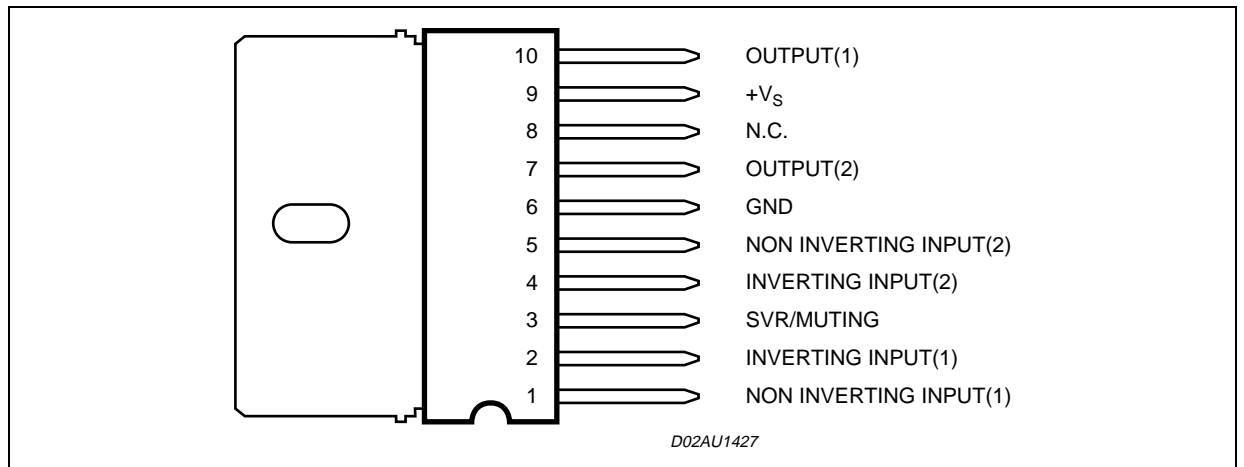
Figure 2. Block Diagram



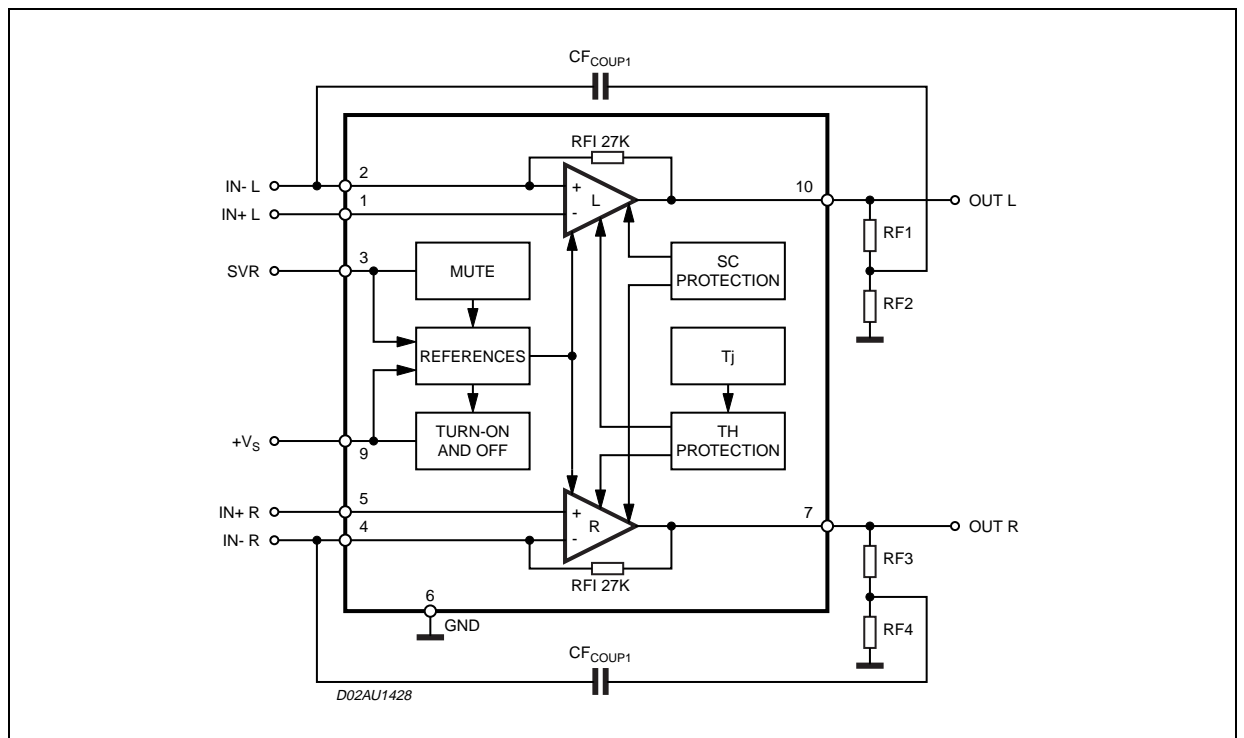
**Table 2. Absolute Maximum Ratings**

Symbol	Parameter	Value	Unit
V <sub>S</sub>	Supply Voltage without Load	30	V
I <sub>O</sub>	Output Peak Current (repetitive f >20Hz)	1.7	A
I <sub>O</sub>	Output Peak Current (non repetitive, t = 100μs)	2	A
P <sub>tot</sub>	Total Power Dissipation (T <sub>case</sub> = 70°C)	8	W
T <sub>op</sub>	Operating Temperature Range	0 to 70	°C
T <sub>stg</sub> , T <sub>j</sub>	Storage & Junction Temperature	-40 to 150	°C

**Figure 3. Pin Connection (Top view)**



**Figure 4. Block Diagram**



**Table 3. Thermal Data**

Symbol	Parameter	Value	Unit
$R_{thj-case}$	Thermal resistance junction to case	Max 9	°C/W

**Table 4. ELECTRICAL CHARACTERISTICS**

(Refer to the stereo test and application circuit,  $V_S = 20V$ ;  $R_L = 8\Omega$ ;  $G_v = 30dB$ ;  $f = 1KHz$ ;  $T_{amb} = 25^\circ C$  unless otherwise specified.)

Symbol	Parameter	Test Condition	Min.	Typ.	Max.	Unit
$V_S$	Supply Voltage		10		24	V
$V_O$	Quiescent Output Voltage			9.5		V
$I_q$	Total Quiescent Current			70	95	mA
$P_O$	Output Power (RMS)	$d = 10\%$ ; $T_{amb} = 85^\circ C$	5	6		W
		$d = 1\%$	4	5		W
$d$	Total Harmonic Distortion	$P_O = 1W$ , $f = 1kHz$		0.03	0.3	%
		$f = 100Hz$ to $10KHz$ ; $P_O = 0.1$ to $3W$			0.5	
$C_T$	Cross Talk	$R_S = 10K\Omega$ ; $f = 1KHz$		70		dB
		$R_S = 10K\Omega$ ; $f = 10KHz$		60		dB
$R_I$	Input Resistance		100	200		$K\Omega$
$f_L$	Low Frequency Roll-off (-3dB)			40		Hz
$f_H$	High Frequency Roll-off (-3dB)			80		KHz
$e_N$	Total Input Noise Voltage	A Curve; $R_S = 10K\Omega$		1.5		mV
		$f = 22Hz$ to $22KHz$ ; $R_S = 10K\Omega$		3	10	V
SVR	Supply Voltage Rejection (each channel)	$R_S = 10K\Omega$ ; $f = 100Hz$ ; $V_r = 0.5V$	45	60		dB
$T_j$	Thermal Shutdown Junction Temperature			145		°C
<b>MUTE FUNCTION</b>						
$V_{T_{MUTE}}$	Mute Threshold		1	1.6		V
$V_{T_{PLAY}}$	Play Threshold			4.5		V
$ATT_{AM}$	Mute Attenuation		70	100		dB
$I_{q_{MUTE}}$	Quiescent Current @ Mute			7	10	mA

### 3 TYPICAL CHARACTERISTICS

(referred to the typical Application Circuit,  $V_S = 20V$ ,  $R_L = 8\Omega$ , unless otherwise specified)

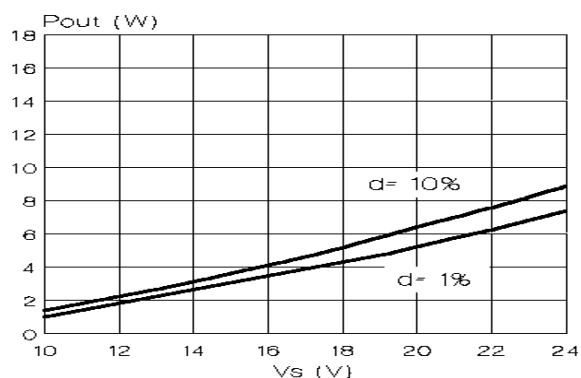
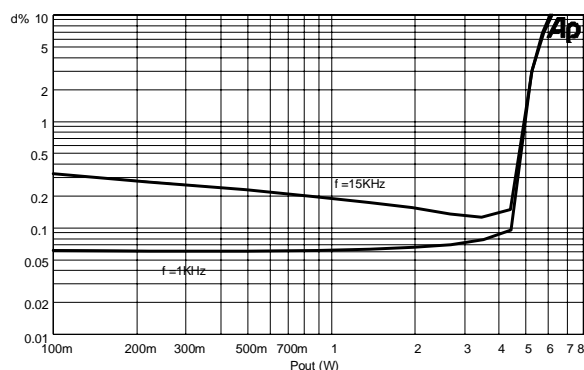
**Figure 5. Output Power vs. Supply Voltage****Figure 6. Distortion vs. Output Power**

Figure 7. Quiescent Current vs. Supply Voltage

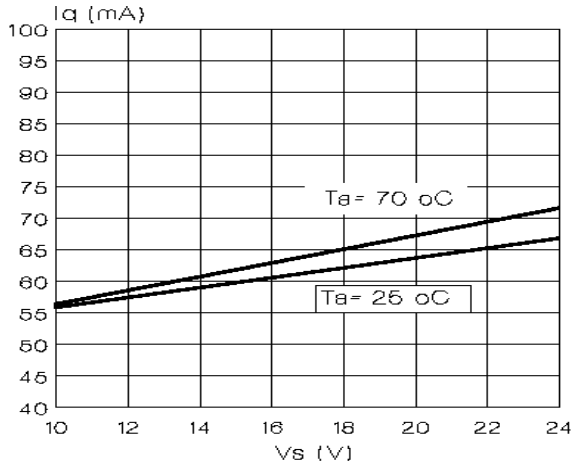


Figure 10. Output Attenuation & Quiescent Current vs. Vpin3

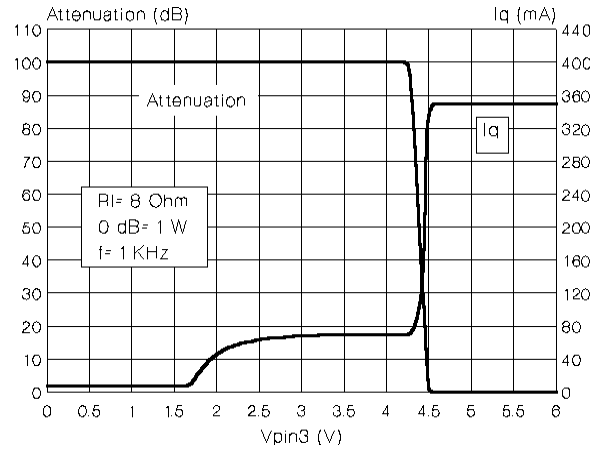


Figure 8. Supply Voltage Rejection vs. Freq.

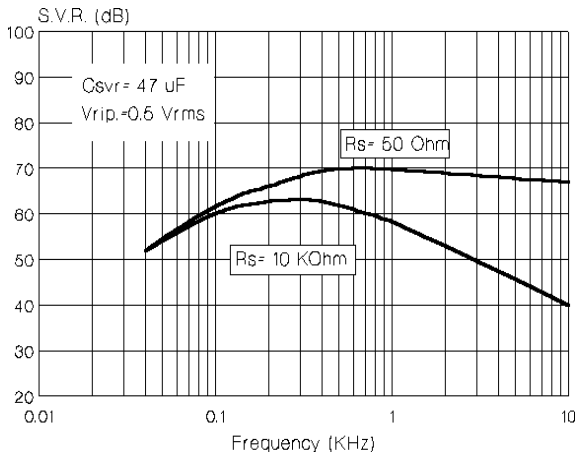


Figure 11. Total Power Dissipation vs. Output Power

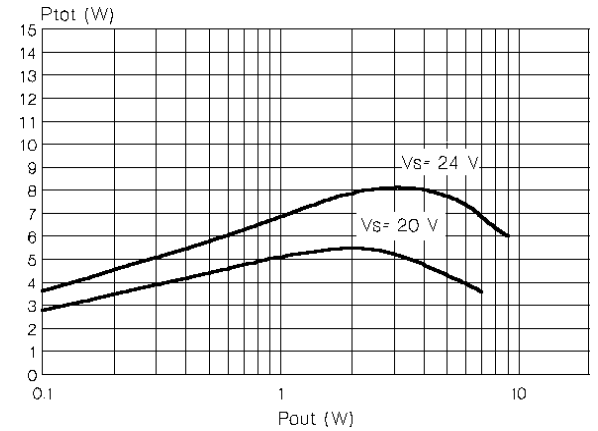


Figure 9. Crosstalk vs. Frequency

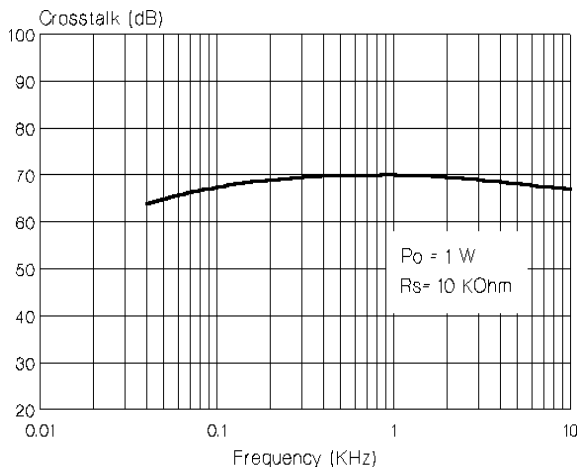


Figure 12. PC Board Component Layout

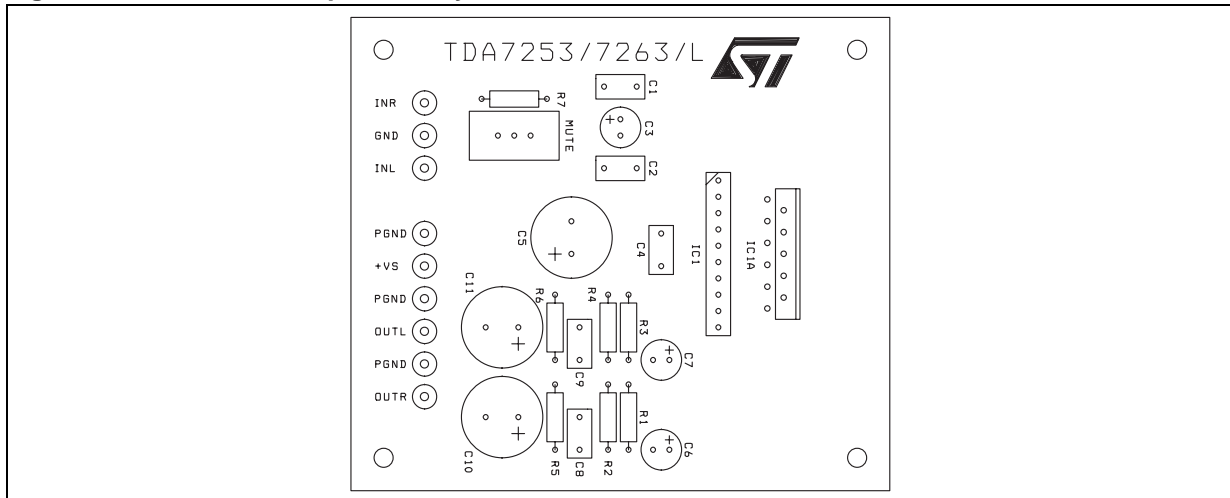


Figure 13. Evaluation Board Top Layer Layout

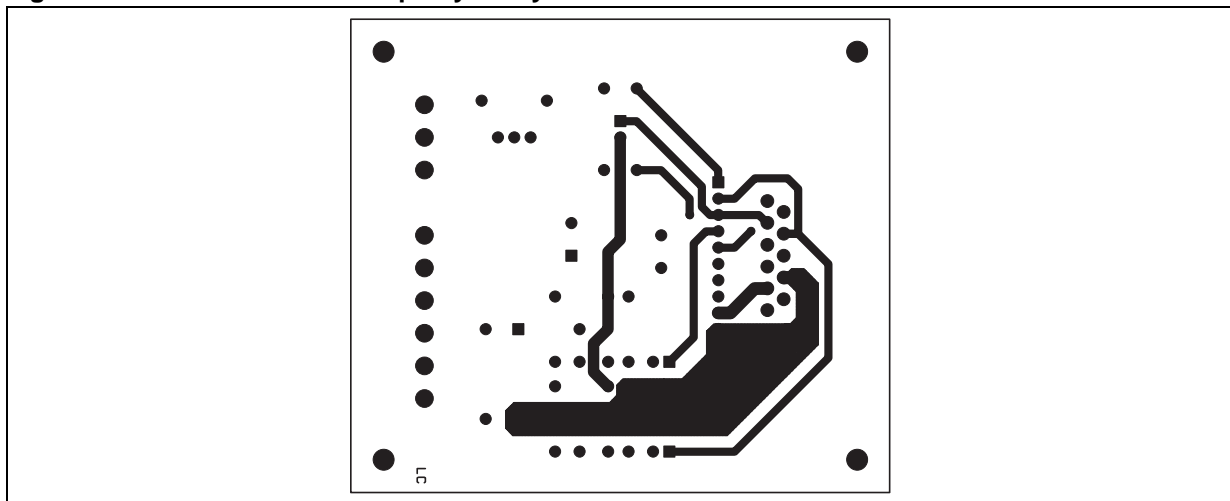
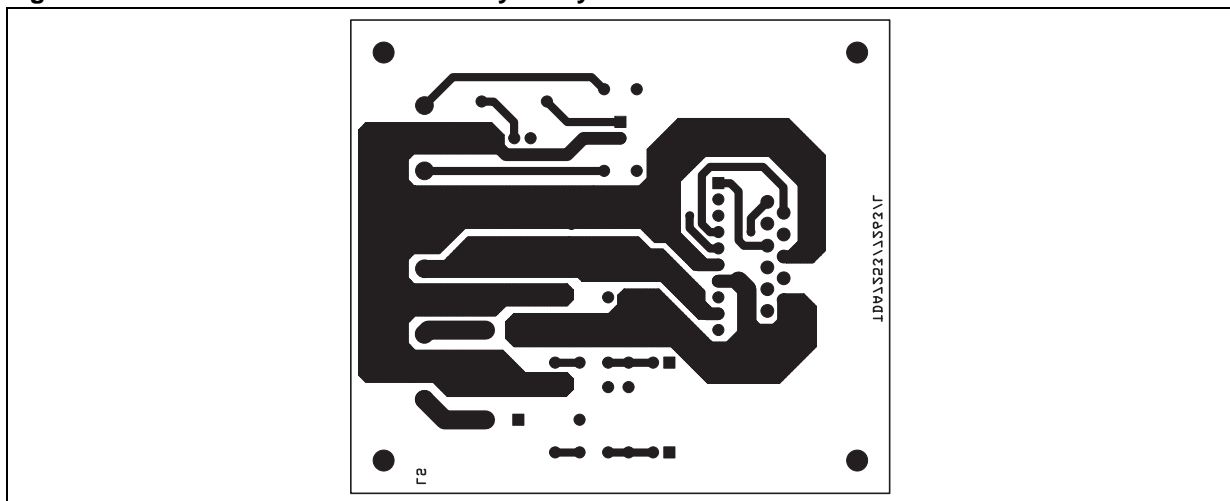


Figure 14. Evaluation Board Bottom Layer Layout



## 4 APPLICATION SUGGESTION

The recommended values of the components are those shown on the typical application circuit. Different values can be used; the following table can help the designer.

Component	Recomm. Value	Purpose	Larger Than	Smaller Than
R1 and R3	1.5K $\Omega$	Close loop gain setting (*)	Increase of gain	Decrease of gain
R2 and R4	47 $\Omega$	Close loop gain setting (*)	Decrease of gain	Increase of gain
R5 and R6	4.7 $\Omega$	Frequency stability	Danger of oscillations	
C1 and C2	100nF	Input DC decoupling	Higher SVR	Higher low frequency cutoff
C3	47 $\mu$ F	- Ripple Rejection - Mute time constant	Increase of the Switch-on time	- Degradation of SVR - Worse turn-off pop by muting
C4	100nF	Supply Voltage Bypass		Danger of oscillations
C5	1000 $\mu$ F	Supply Voltage Bypass		
C6 and C7	47 $\mu$ F	Feedback input DC decoupling	Increase of the Switch-on time	Danger of Switch-on time
C8 and C9	0.1 $\mu$ F	Frequency stability		Danger of oscillations
C10 and C11	1000 $\mu$ F	Output DC decoupling		Higher low-frequency cut-off

(\*) Closed loop gain must be higher than 26dB

## 5 BUILT-IN PROTECTION SYSTEMS

### 5.1 Thermal Shut-down

The presence of a thermal limiting circuit offers the following advantages:

- 1 an overload on the output (even if it is permanent), or an excessive ambient temperature can be easily withstood.
- 2 the heatsink can have a smaller factor of safety compared with that of a conventional circuit. There is no device damage in the case of excessive junction temperature; if for any reason the junction temperature increases up to 145°C. the thermal shutdown simply reduces the output power and therefore the power dissipation.

The maximum allowable power dissipation depends upon the thermal resistance junction-ambient. Figure 15 shows the dissippable power as a function of ambient temperature for different heatsink thermal resistance.

### 5.2 Short Circuit (AC Conditions)

The TDA7263L can withstand accidental short circuits across the speaker made by a wrong connection during normal play operation.

## 6 HEAT SINK DIMENSIONING:

In order to avoid the thermal protection intervention, that is placed approximatively at  $T_j = 150^\circ\text{C}$ , it is important the dimensioning of the Heat Sinker  $R_{Th}$  ( $^\circ\text{C}/\text{W}$ ).

The parameters that influence the dimensioning are:

- Maximum dissipated power for the device ( $P_{dmax}$ )
- Max thermal resistance Junction to case ( $R_{Th\ j-c}$ )
- Max. ambient temperature  $T_{amb\ max}$
- Quiescent current  $I_q$  (mA)

### 6.1 Example:

$V_{CC} = 20\text{V}$ ,  $R_{load} = 80\text{ohm}$ ,  $R_{Th\ j-c} = 9\ ^\circ\text{C}/\text{W}$ ,  $T_{amb\ max} = 50^\circ\text{C}$

$$P_{dmax} = (N^\circ \text{ channels}) \cdot \frac{2V_{CC}^2}{\Pi^2 \cdot R_{load}} + I_q \cdot V_{CC}$$

$$P_{dmax} = 2 \cdot (2.5) + 0.5 = 5.5\text{W}$$

$$(\text{Heat Sinker}) R_{Th\ c-a} = \frac{150 - T_{amb\ max}}{P_{d\ max}} - R_{Th\ j-c} = \frac{150 - 50}{5.5} - 9 = 9.0^\circ\text{C}/\text{W}$$

In figure 11 is shown the Power derating curve for the device.

**Figure 15. Power Derating Curve**

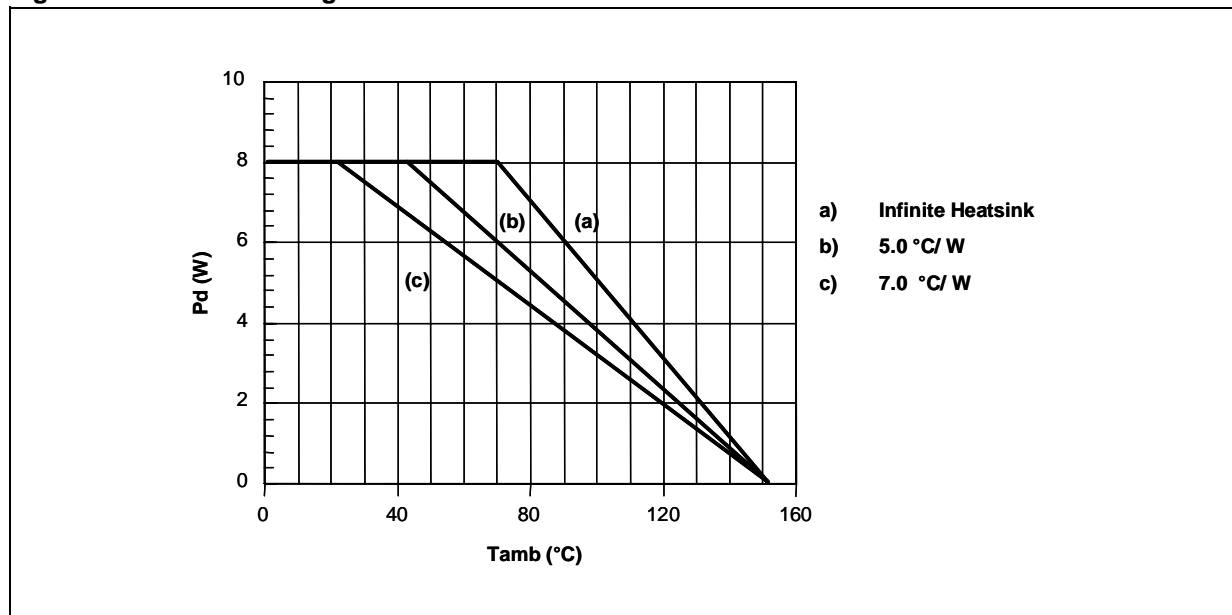
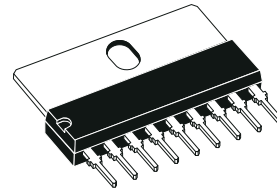


Figure 16. SIP10 Mechanical Data & Package Dimensions

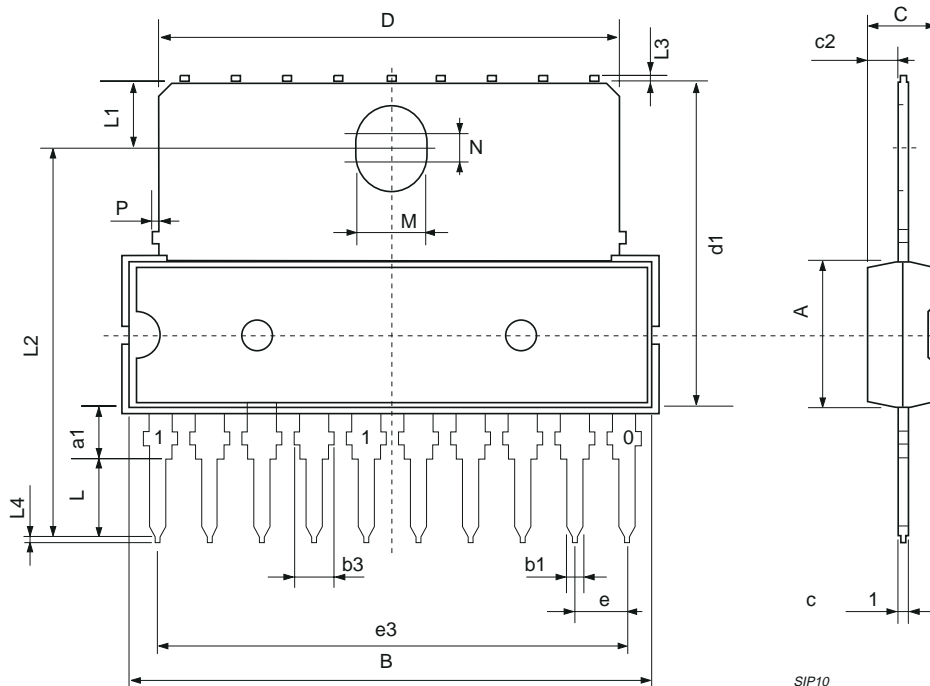
DIM.	mm			inch		
	MIN.	TYP.	MAX.	MIN.	TYP.	MAX.
A			7.1			0.280
a1	2.7		3	0.106		0.118
B			24.8			0.976
b1		0.5			0.020	
b3	0.85		1.6	0.033		0.063
C		3.3			0.130	
c1		0.43			0.017	
c2		1.32			0.052	
D			23.7			0.933
d1		14.5			0.571	
e		2.54			0.100	
e3		22.86			0.900	
L	3.1			0.122		
L1		3			0.118	
L2		17.6			0.693	
L3			0.25			0.010
L4			0.254			0.010
M		3.2			0.126	
N		1			0.039	
P			0.15			0.006

**OUTLINE AND MECHANICAL DATA**

Weight: 2.02gr



**SIP10**



SIP10

0016108 D



**Table 5. Revision History**

Date	Revision	Description of Changes
June 2003	1	First Issue
September 2004	2	Changed Status and the graphic aspect in compliant to the new rules "Corporate Technical Publications Design Guide"

Information furnished is believed to be accurate and reliable. However, STMicroelectronics assumes no responsibility for the consequences of use of such information nor for any infringement of patents or other rights of third parties which may result from its use. No license is granted by implication or otherwise under any patent or patent rights of STMicroelectronics. Specifications mentioned in this publication are subject to change without notice. This publication supersedes and replaces all information previously supplied. STMicroelectronics products are not authorized for use as critical components in life support devices or systems without express written approval of STMicroelectronics.

The ST logo is a registered trademark of STMicroelectronics.  
All other names are the property of their respective owners

© 2004 STMicroelectronics - All rights reserved

STMicroelectronics group of companies

Australia - Belgium - Brazil - Canada - China - Czech Republic - Finland - France - Germany - Hong Kong - India - Israel - Italy - Japan -  
Malaysia - Malta - Morocco - Singapore - Spain - Sweden - Switzerland - United Kingdom - United States of America

[www.st.com](http://www.st.com)