

IR Sensor Module for Remote Control Systems

Description

The TSOP98200 is a miniaturized sensor for receiving the modulated signal of infrared remote control systems. A PIN diode and preamplifier are assembled on a lead frame, the epoxy package is designed as an IR filter. The modulated output signal, Carrier Out, can be used for code learning applications. This component has not been qualified according to automotive specifications.

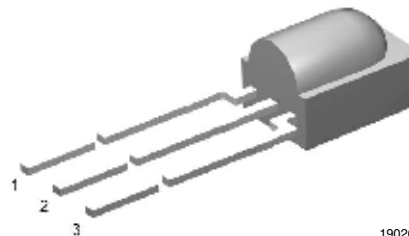

19026

Features

- Photo detector and preamplifier in one package
- AC coupled response from 20 kHz - 455 kHz, all data formats
- Improved shielding against electrical field disturbance
- TTL and CMOS compatibility
- Output active low
- Supply voltage: 2.7 V to 5.5 V
- Carrier Out signal for code learning functions
- Lead (Pb)-free component
- Component in accordance to RoHS 2002/95/EC and WEEE 2002/96/EC



Mechanical Data

Pin Description:

1 = Carrier OUT, 2 = GND, 3 = V_S

Block Diagram

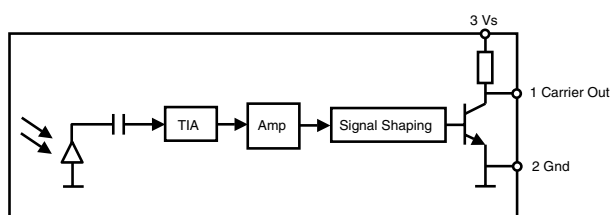

19746

Application Circuit

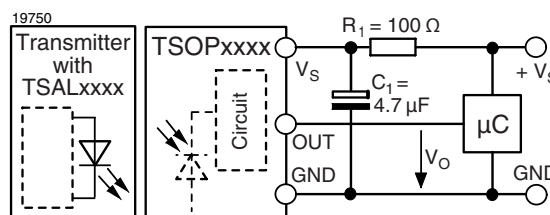

$R_1 + C_1$ recommended to suppress power supply disturbances.



Absolute Maximum Ratings

T_{amb} = 25 °C, unless otherwise specified

Parameter	Test condition	Symbol	Value	Unit
Supply Voltage	(Pin 3)	V _S	- 0.3 to + 5.5	V
Output Voltage	(Pin 1)	V _O	- 0.3 to (V _S + 0.3)	V
Output Current	(Pin 1)	I _O	10	mA
Junction Temperature		T _j	100	°C
Storage Temperature Range		T _{stg}	- 25 to + 85	°C
Operating Temperature Range		T _{amb}	- 25 to + 85	°C
Soldering Temperature	t ≤ 10 s, 1 mm from case	T _{sd}	260	°C

Electrical and Optical Characteristics Carrier Out

T_{amb} = 25 °C, unless otherwise specified

V_S = 3 V

Parameter	Test condition	Symbol	Min	Typ.	Max	Unit
Supply Current (Pin 3)	E _v = 0	I _{SD}		0.6	0.8	mA
Supply Voltage		V _S	2.7		5.5	V
Output Voltage Low (Pin 1)	I _{OSL} = 0.5 mA, test signal see fig. 1	V _{OSL}			250	mV
Maximum Irradiance	test signal see fig. 1 (20 - 60* kHz)	E _{e max}	300	500		W/m ²
Directivity	Angle of half transmission distance	φ _{1/2}		± 45		deg
Transmission Distance	E _v = 0, test signal see fig. 1, IR diode TSAL6200, I _F = 400 mA	d		1		m
Threshold Irradiance	V _S = 3 V (20 - 60* kHz)	E _{e min}		0.3	0.5	W/m ²
Carrier Out rise time	V _S = 3 V, C _L = 10 pF	T _R		100		ns
Carrier Out fall time	V _S = 3 V, C _L = 10 pF	T _F		10		ns
Output pulse width	T _{PI} = 10 μs, C _L = 10 pF	T _{PO}	0.6	1.1	1.6	μs

* These irradiance values are guaranteed to 60 kHz. The TSOP98200 will continue to function up to frequencies higher than 600 kHz, however the irradiance at frequencies above 60 kHz is dependent on the carrier frequency and the pulse pattern received. Typical E_{e min} = 2 W/m² at 455 kHz.

Typical Characteristics

$T_{amb} = 25\text{ }^{\circ}\text{C}$, unless otherwise specified

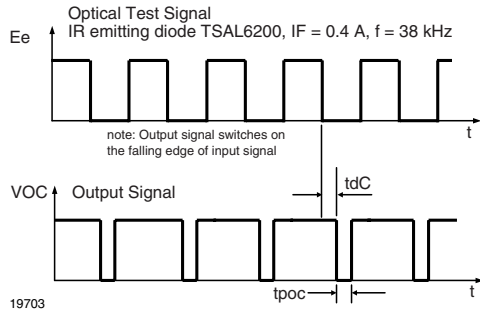

Figure 1. Carrier Output Pulse Diagram

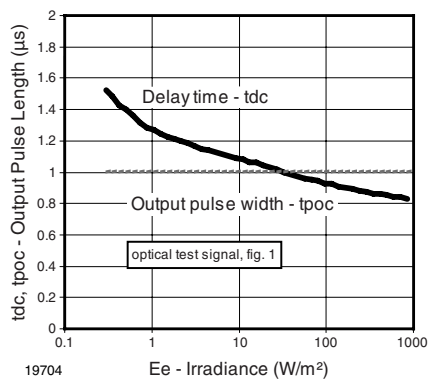

Figure 2. Carrier Output Function Diagram

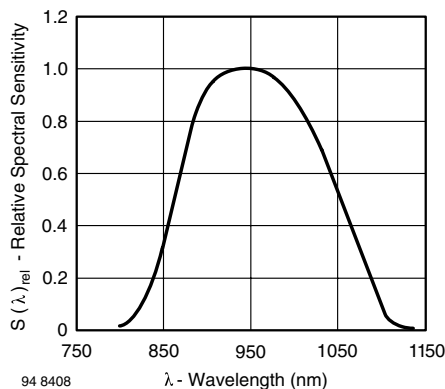

Figure 3. Relative Spectral Sensitivity vs. Wavelength

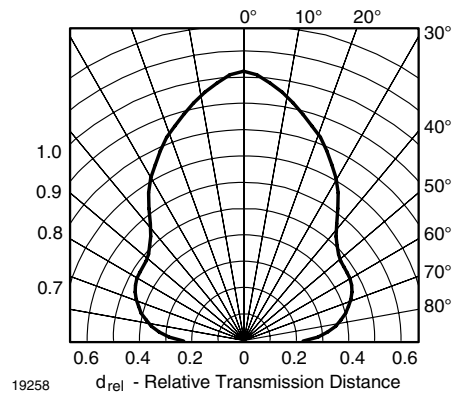

Figure 4. Horizontal Directivity ϕ_x

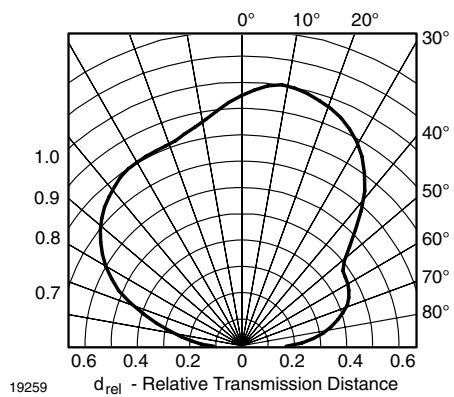
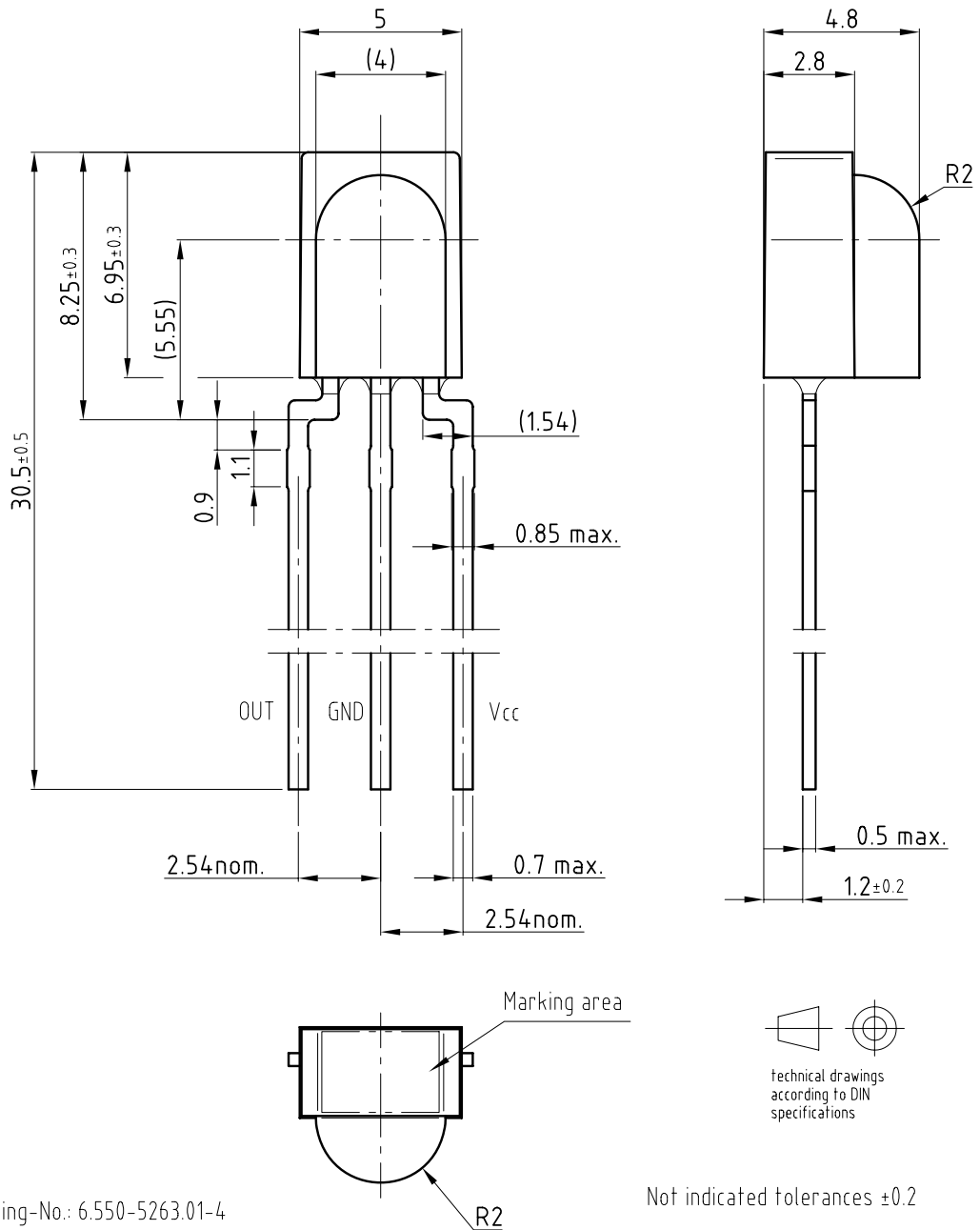

Figure 5. Vertical Directivity ϕ_y

Package Dimensions in millimeters



technical drawings according to DIN specifications

Not indicated tolerances ±0.2

Drawing-No.: 6.550-5263.01-4
 Issue: 9; 16.02.07
 19009

Ozone Depleting Substances Policy Statement

It is the policy of Vishay Semiconductor GmbH to

1. Meet all present and future national and international statutory requirements.
2. Regularly and continuously improve the performance of our products, processes, distribution and operating systems with respect to their impact on the health and safety of our employees and the public, as well as their impact on the environment.

It is particular concern to control or eliminate releases of those substances into the atmosphere which are known as ozone depleting substances (ODSs).

The Montreal Protocol (1987) and its London Amendments (1990) intend to severely restrict the use of ODSs and forbid their use within the next ten years. Various national and international initiatives are pressing for an earlier ban on these substances.

Vishay Semiconductor GmbH has been able to use its policy of continuous improvements to eliminate the use of ODSs listed in the following documents.

1. Annex A, B and list of transitional substances of the Montreal Protocol and the London Amendments respectively
2. Class I and II ozone depleting substances in the Clean Air Act Amendments of 1990 by the Environmental Protection Agency (EPA) in the USA
3. Council Decision 88/540/EEC and 91/690/EEC Annex A, B and C (transitional substances) respectively.

Vishay Semiconductor GmbH can certify that our semiconductors are not manufactured with ozone depleting substances and do not contain such substances.

We reserve the right to make changes to improve technical design
and may do so without further notice.

Parameters can vary in different applications. All operating parameters must be validated for each customer application by the customer. Should the buyer use Vishay Semiconductors products for any unintended or unauthorized application, the buyer shall indemnify Vishay Semiconductors against all claims, costs, damages, and expenses, arising out of, directly or indirectly, any claim of personal damage, injury or death associated with such unintended or unauthorized use.

Vishay Semiconductor GmbH, P.O.B. 3535, D-74025 Heilbronn, Germany



Disclaimer

All product specifications and data are subject to change without notice.

Vishay Intertechnology, Inc., its affiliates, agents, and employees, and all persons acting on its or their behalf (collectively, "Vishay"), disclaim any and all liability for any errors, inaccuracies or incompleteness contained herein or in any other disclosure relating to any product.

Vishay disclaims any and all liability arising out of the use or application of any product described herein or of any information provided herein to the maximum extent permitted by law. The product specifications do not expand or otherwise modify Vishay's terms and conditions of purchase, including but not limited to the warranty expressed therein, which apply to these products.

No license, express or implied, by estoppel or otherwise, to any intellectual property rights is granted by this document or by any conduct of Vishay.

The products shown herein are not designed for use in medical, life-saving, or life-sustaining applications unless otherwise expressly indicated. Customers using or selling Vishay products not expressly indicated for use in such applications do so entirely at their own risk and agree to fully indemnify Vishay for any damages arising or resulting from such use or sale. Please contact authorized Vishay personnel to obtain written terms and conditions regarding products designed for such applications.

Product names and markings noted herein may be trademarks of their respective owners.