

# NUTS AND VOLTS

www.nutsvolts.com  
September 2011

EVERYTHING FOR ELECTRONICS

Connect Your

## HOME THERMOSTAT

## To The Internet

And Control It From Any  
Web or Cell Phone Browser

### ◆ Circuit Board Assembly Jig

Build this convenient  
3rd hand to help in  
assembling PCBs.

### ◆ Designing The DEFCON 18 Badge

An inside look behind  
this years build.

### ◆ Propeller Powered Servo Control

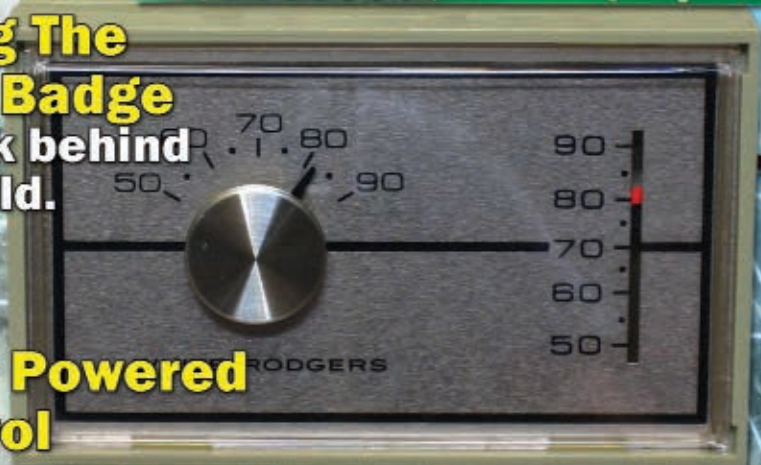
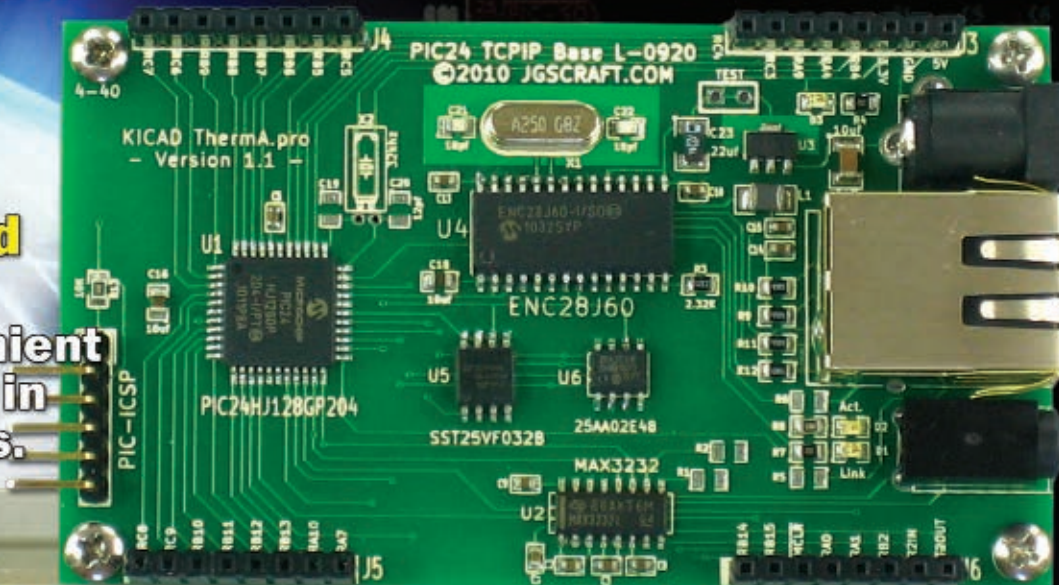

U.S. \$6.50 CANADA \$7.50



Announcing a complete hardware and software solution from NetBurner

# The NetBurner MOD5234

ETHERNET CORE MODULE with eTPU



Only **\$99**  
Qty. 100

## NetBurner MOD5234 Ethernet Core Module Features

### INDUSTRIAL TEMPERATURE RANGE

| -40°C to +85°C

### PERFORMANCE AND MEMORY

| 32-Bit CPU | Freescale ColdFire MCF5234 147 Mhz  
| 2MB Flash Memory | 8MB SDRAM

### DEVICE CONNECTIVITY

| 10/100 Ethernet | 3 UARTs | 16-channel eTPU | I<sup>2</sup>C | SPI | CAN  
| 47 Digital I/O | 16-bit Data Bus | SD/MMC Flash Card Support

## Customize with NetBurner's Royalty-free Software Suite

### DEVELOPMENT SOFTWARE

| NB Eclipse IDE | Graphical Debugger | Deployment Tools | Examples

### COMMUNICATION SOFTWARE

| TCP/IP Stack | HTTP Web Server | FTP | E-Mail | PPP | Flash File System

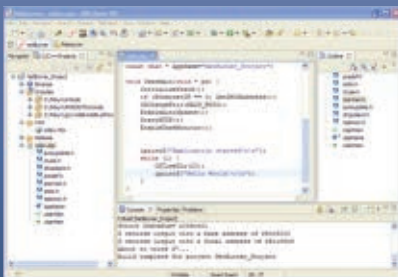
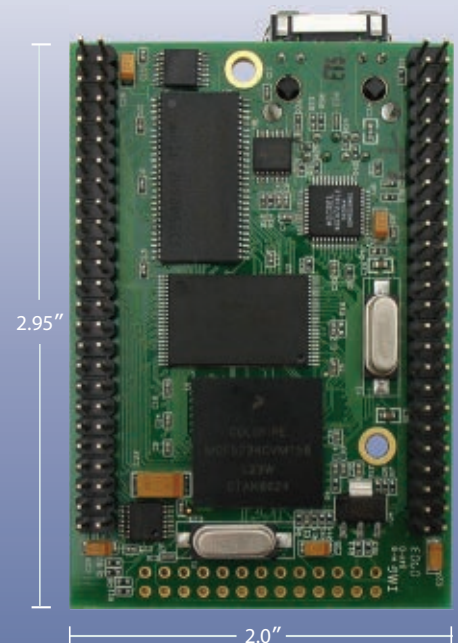

All hardware and software is included with the

## NetBurner MOD5234 Development Kit for only \$299!











The Development Kit features NetBurner's Eclipse, an enterprise level professional IDE that provides editing, downloading and debugging in one environment.

**Order the MOD5234 Development Kit: Product No. NNDK-MOD5234-KIT**



Product No. | MOD5234-100IR  
Information and Sales | [sales@netburner.com](mailto:sales@netburner.com)  
Web | [www.netburner.com](http://www.netburner.com)  
Telephone | 1-800-695-6828



-  Start Debugger [F9]
-  Run/Pause Debugger [F6]
-  Stop Debugger [Ctrl+F2]
-  Step into [F7]
-  Step Out [Ctrl+F8]
-  Run To Cursor [F4]
-  Step Over [F8]
-  Show/Hide Breakpoints [Shift+F4]
-  Toggle Breakpoint [F5]
-  Clear breakpoints [Ctrl+Shift+F5]
-  Jump To Interrupt [F2]



# mikroProg™ \$99

programmer and In-Circuit Debugger

## One programmer to rule them all.



One programmer for 574 devices  
**All PICs covered**  
 PIC10, PIC12, PIC16, PIC18, dsPIC30/33, PIC24 and PIC32, we have it all covered. You'll never need another programmer!



In-Circuit Debugger Supported  
**Fast mikroICD™ debugger**  
 Debug your code and monitor code execution on the chip itself. mikroICD™ technology brings the power of hardware debugging to your favorite mikroE compiler.



Single firmware takes care of it all  
**Supporting new chips is easy**  
 Adding new chips is easy. Just download the latest mikroProg Suite Software, and new devices will be available using the same hardware and the same firmware inside!



Support in 9 mikroE compilers  
**Compiler Compatibility**  
 mikroProg™ is supported with mikroC, mikroBasic and mikroPascal compilers for PIC, dsPIC and PIC32.

# BitScope

## Digital + Analog

### 100 MHz Digital Oscilloscope

- ✓ Dual Channel Digital Storage Oscilloscope with up to 12 bit analog sample resolution and high speed real-time waveform display.

### 40 MSPS x 8 Channel Logic Analyzer

- ✓ Captures eight logic/timing signals together with sophisticated cross-triggers for precise multi-channel mixed signal measurements.

### Serial Logic and Protocol Analyzer

- ✓ Capture and analyze SPI, CAN, I2C, UART & logic timing concurrently with analog. Solve complex system control problems with ease.

### Real-Time Spectrum Analyzer

- ✓ Display analog waveforms and their spectra simultaneously in real-time. Baseband or RF signals with variable bandwidth control.

### Waveform and Logic Generators

- ✓ Generate an arbitrary waveform and capture analog & digital signals concurrently or create programmable logic and/or protocol patterns.

### Multi-Channel Chart Recorder

- ✓ Record to disk anything BitScope can capture. Allows off-line replay and waveform analysis. Export captured waveforms and logic signals.

Everything in one tiny package !



**BitScope Pocket Analyzer** is the world's first Mixed Signal Scope to include a powerful Logic Protocol Analyzer, Waveform & Pattern Generator, Spectrum Analyzer and Chart Recorder in one ultra-portable **USB powered** package.

Pocket Analyzer is fast, displaying up to 100 frames per second with up to 12kS per frame. Alternatively stream data direct to disk for replay and analysis.

Compatible with major operating systems including Windows, Linux & Mac OS X, Pocket Analyzer is your ideal test and measurement companion.

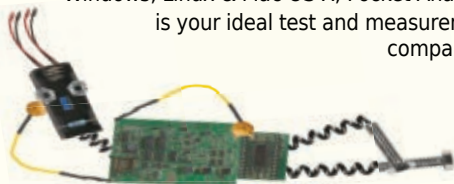

## Mixed Signal Oscilloscopes



### Pocket Analyzer



## Protocol Analyzer



## Digital Oscilloscope

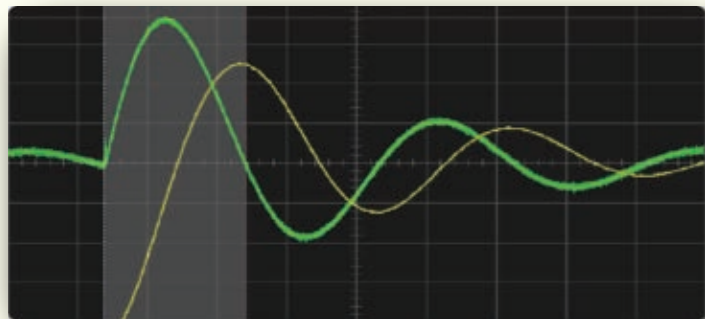

## Spectrum Analyzer

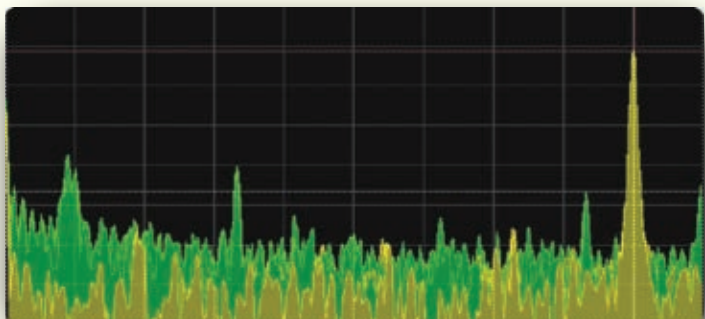

[bitscope.com/nv](http://bitscope.com/nv)



**microEngineering Labs, Inc.**

[www.melabs.com](http://www.melabs.com)

888-316-1753

In celebration of 15 years of service,  
microEngineering Labs proudly presents  
the latest evolution of the industry-standard  
BASIC compiler for Microchip PIC® microcontrollers.

# **PBP3**

**PICBASIC PRO™ Compiler**

## **Experimenter Edition - \$49.95**

Supporting select 28-pin devices

## **Silver Edition - \$119.95**

Supporting Microchip's Mid-Range Architecture

## **Gold Edition - \$269.95**

Supporting more than 500 microcontrollers

Download a FREE trial version now.

**[www.PBP3.com](http://www.PBP3.com)**

PICBASIC PRO is a trademark of Microchip Technology Inc. in the USA and other countries.  
PIC is a registered trademark of Microchip Technology Inc. in the USA and other countries.



Page 10



Page 14

## Projects & Features

### 28 Build A Circuit Board Assembly Jig

If you spend a considerable amount of time assembling and soldering PCBs, then you're gonna love this "third hand" you're always needing.

■ *By John D. Collier*

### 34 Web Browser Control of Your Home Thermostat – Part 1

Control the temperature from your easy chair (or remotely from anywhere!) with a cell phone browser or computer.

■ *By Jürgen G. Schmidt*

### 44 Making the DEFCON 18 Badge

Joe's yearly summary on the trials and tribulations of his badge build.

■ *By Joe Grand*

## Columns

### 10 TechKnowledge 2011 *Events, Advances, and News*

This month's coverage includes info on harvesting wasted vehicle power, docking your hard drives, Apple taking the biggest semi bite, plus some other food for thought.

### 14 The Spin Zone *Adventures in Propeller Programming*

Serving Up Servo Control.

### 22 Q & A *Reader Questions Answered Here*

Get answers to a solar controller, 1.5V hobby motor speed controller, a DSL carrier detector, and some other stuff.

### 52 Near Space *Approaching the Final Frontier*

Programming the Ultralight Near Space Flight Computer.

### 58 Smiley's Workshop *Programming • Hardware • Projects*

avrtoolbox and C Standard Library.

### 68 The Design Cycle *Advanced Techniques for Design Engineers*

Slaving Away From USB Host.

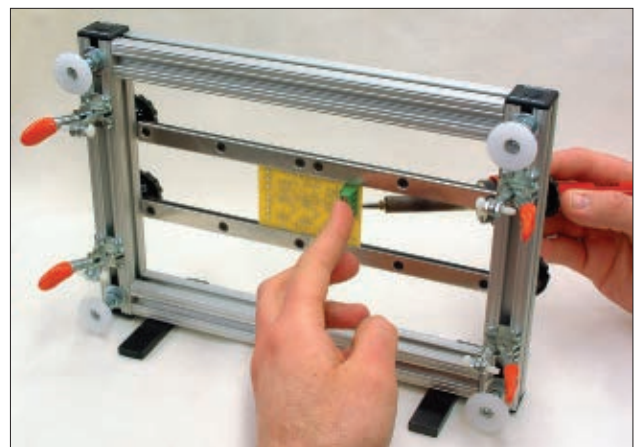

Page 28

## Departments

<b>08</b>	<b>DEVELOPING PERSPECTIVES</b>	<b>65</b>	<b>NV WEBSTORE</b>
<b>26</b>	<b>NEW PRODUCTS</b>	<b>78</b>	<b>TECH FORUM</b>
<b>27</b>	<b>SHOWCASE</b>	<b>79</b>	<b>AD INDEX</b>
<b>64</b>	<b>ELECTRO-NET</b>	<b>80</b>	<b>CLASSIFIEDS</b>

### FUNDamentals For Beginners

Just getting started in electronics? Try these simple demos to illustrate electronics principles and how components function in actual circuits!

### 56 Build an Electronic Metronome

# INNOVATIVE TRAINING SOLUTIONS



## Combinational Logic Trainer DL-010

Teaches the initial concepts of AND, OR, and XOR gates.

\*Includes training manual featuring overviews of digital logic & 60 hands-on experiments



## Sequential Logic Trainer DL-020

Introduces the concept of conditional feedback includes D Flip-flop, NAND gates, and 4-to-1 Multiplexer.

\*Includes training manual



## External Powered Breadboard PB-103

Breadboard capable of being used to design a multitude of analog, digital, logic and microcomputer circuits.



## Portable Analog & Digital Design Workstation PB-503C

Ideal for analog, digital and microprocessor circuits.

Suitable for all levels.



## Surface Mount Device Soldering & Re-Work Tool Kit GST-SMT-1

The set includes 11 tools commonly used for working with surface mount components.



## 48-Pin TSOP to Through - Hole Prototyping Adapter GSPA-TSOP-48S



## Offer Selection of Over 18 DIY Educational Kits GSK-1001



**Global**<sup>®</sup>  
Specialties

For more information visit us at  
[www.Globalspecialties.com](http://www.Globalspecialties.com)



by Bryan Bergeron, Editor

# DEVELOPING PERSPECTIVES

## Putting A Pretty Face On Your Next Project

In this age of the Apple iPad and Microsoft Kinect, it's hard to achieve a gee-wiz factor when you're using old-fashioned toggle switches as the user interface elements of your latest electronics project. However, thanks to inexpensive microcontrollers and readily repurposed user interface tools, your next project could sport an intuitive, efficient user interface. I'm not suggesting that you should avoid mechanical switches and potentiometers on, say, a power supply. However, if you're building a robot controller, sequencer, or other complex device that would normally include an array of switches, potentiometers, and indicators, then consider the alternatives.

One approach is to build your own touch-screen interface using a screen from a discarded Nintendo DS or Chumby. Another is to use a touch shield for the Arduino, such as the capacitive touch interface shield available from SparkFun. However, this alternative lacks the visual feedback that's commonly associated with touch-screens.

I think that the best approach to acquiring a slick interface is to repurpose one of the many interface devices that support MIDI – the Musical Instrument

Digital Interface. You'll find an abundance of inexpensive, easily repurposed MIDI interfaces designed for musicians listed on the Web. If you're working with audio – including analog-to-digital conversion and remote, audio-based switching – then going the MIDI route is a no-brainer.

Although the MIDI standard or protocol has been around since the early 1980s, it continues to enable modern electronic gadgets. For example, just about every computer compatible keyboard or synthesizer has MIDI input and output. I have a MIDI guitar, as well as an electronic drum set that are both MIDI devices. In addition, I recently purchased several apps for my iPad that work with MIDI hardware.

Connecting a MIDI device to a standard PC or Mac is as simple as purchasing a \$5 MIDI to USB cable. Unfortunately, the equivalent cable for the iPad is about \$40. I assume the cables for Android-based tablets are more reasonable.

Many MIDI-compatible control surfaces designed for musicians can be used for a variety of projects without modification. If you search for 'MIDI Controller' on the Web, you'll also find dozens of sub-\$50 MIDI to USB keyboards and percussion interfaces. Some interfaces cost considerably more, depending on their functionality. For example, I've been working with the

Korg Kaossilator Pro (\$400) – a music synthesizer that doubles as a graphic MIDI controller. The tablet-sized device transmits numerical MIDI codes as a function of rubbing, stroking, or tapping the 8 x 8 LED grid with a finger. Then, there's the more affordable Novation Launchpad (\$150) – a dedicated MIDI controller with a similar 8 x 8 grid user interface. If your interface needs are more toward traditional sliders and faders, then there's the Numark DJ2GO controller (\$60). All three interfaces connect to a computer via USB.

How you enable your projects with these interfaces is up to your imagination. With the addition of a microcontroller, just about anything is possible. For example, I've used a Korg MIDI controller and an Arduino-intermediary to control a

**MOTORS  
GEARBOXES  
WHEELS  
AND MORE**

**BB BaneBots** **BANEBOTS.COM**  
970-461-8880



# NUTS AND VOLTS

EVERYTHING FOR ELECTRONICS

Published Monthly By  
**T & L Publications, Inc.**

430 Princeland Ct.  
Corona, CA 92879-1300

(951) 371-8497

FAX (951) 371-3052

Webstore orders only **1-800-783-4624**

[www.nutsvolts.com](http://www.nutsvolts.com)

## Subscriptions

Toll Free **1-877-525-2539**

Outside US **1-818-487-4545**

P.O. Box 15277

North Hollywood, CA 91615

## FOUNDER/ASSOCIATE PUBLISHER

Jack Lemieux

## PUBLISHER

Larry Lemieux

[publisher@nutsvolts.com](mailto:publisher@nutsvolts.com)

## ASSOCIATE PUBLISHER/ VP OF SALES/MARKETING

Robin Lemieux

[display@nutsvolts.com](mailto:display@nutsvolts.com)

## EDITOR

Bryan Bergeron

[techedit-nutsvolts@yahoo.com](mailto:techedit-nutsvolts@yahoo.com)

## CONTRIBUTING EDITORS

Jeff Eckert

Russ Kincaid

Joe Pardue

Fred Eady

Jon Williams

Paul Verhage

Joe Grand

John Collier

Jürgen Schmidt

## CIRCULATION DIRECTOR

Tracy Kerley

[subscribe@nutsvolts.com](mailto:subscribe@nutsvolts.com)

## SHOW COORDINATOR

Audrey Lemieux

## MARKETING COORDINATOR

### WEBSTORE

Brian Kirkpatrick

[sales@nutsvolts.com](mailto:sales@nutsvolts.com)

### WEB CONTENT

Michael Kaudze

[website@nutsvolts.com](mailto:website@nutsvolts.com)

## ADMINISTRATIVE ASSISTANT

Debbie Stauffacher

## PRODUCTION/GRAPHICS

Shannon Christensen

Copyright © 2011 by T & L Publications, Inc.  
All Rights Reserved

All advertising is subject to publisher's approval. We are not responsible for mistakes, misprints, or typographical errors. *Nuts & Volts Magazine* assumes no responsibility for the availability or condition of advertised items or for the honesty of the advertiser. The publisher makes no claims for the legality of any item advertised in *Nuts & Volts*. This is the sole responsibility of the advertiser. Advertisers and their agencies agree to indemnify and protect the publisher from any and all claims, action, or expense arising from advertising placed in *Nuts & Volts*. Please send all editorial correspondence, UPS, overnight mail, and artwork to: 430 Princeland Court, Corona, CA 92879.

Printed in the USA on SFI & FSC stock.  

graphical program that I wrote in Processing on my PC. If you check the Arduino site, you'll see that 'talking MIDI' is a simple two-wire serial communications protocol affair. Of course, just about any microprocessor will do, as long as it can keep up with the 31.25K bps communications rate. I've had great luck with the inexpensive, high speed Arduino Mega clone — ChipKit Max32 (\$50) — from Digilent.

If you're new to MIDI and the numerous options available for controlling your next project seem overwhelming, then check out the tutorials on the Arduino site ([arduino.cc](http://arduino.cc)). You should also consider the MIDI shields and breakout boards, and documentation on the MIDI boards available from SparkFun ([www.sparkfun.com](http://www.sparkfun.com)). It also wouldn't hurt to spend an hour in your local music store to see how the various MIDI tools work in their intended environments. **NV**



**SABERTOOTH**  
**2X12 AND 2X12RC**

The most popular small dual motor controllers... Just got better!

DimensionEngineering  
Welcome to the next generation of efficiency, performance, and value.

Specifications:

- 1A 5V Switching BEC
- 6-24V Input Voltage
- 2 x 12A Continuous Current
- 2 x 25A Peak Current

Features:

- Synchronous Regeneration
- Ultra Fast Switching Frequency (no whine!)
- Thermal, Overcurrent, and Lithium Protection
- Serial, R/C, and Analog Inputs

Sabertooth 2x12 \$79.99

Sabertooth 2x12RC \$64.99

(330) 634-1430  
[www.dimensionengineering.com](http://www.dimensionengineering.com)

- Motor Controllers - DC to DC - Sensors - R/C Relays - R/C Lighting -



**XBee gave your data wings.**  
**Synapse gives it jetpacks**  
...that are powered by rabid honey badgers.

The Synapse Wireless communication system gives you more range, more I/O, and an easier python-based interface. Try them out for your next wireless project! (XBee adapters available too)

Learn more at: [solarbotics.com/resources/projects/synapse/](http://solarbotics.com/resources/projects/synapse/)

**SOLARBOTICS**  
www.solarbotics.com 1-866-276-2687

PS - Do you have any idea how hard it is to strap a backpack onto individual bits of digital information? Not easy. We won't even mention handling the badgers...



■ BY JEFF ECKERT

## ADVANCED TECHNOLOGY

### HARVESTING WASTED VEHICLE POWER

Most of the electrical energy-harvesting concepts that have emerged lately have worked on a relatively small scale, such as wireless sensor networks, wearable electronics, and so forth. A range of energy sources have been tapped, including thermal gradients, vibration, blood sugar, and even trees, with various degrees of success. However, an Israeli company called Innowattech ([www.innowattech.co.il](http://www.innowattech.co.il)) has been working on large-scale applications of piezoelectric technology to generate more than just incidental currents. For those who are unfamiliar with the piezoelectric effect, we note that, way back in 1880 the Curie brothers discovered that certain crystals generate an electric current when deformed under pressure (known as the "direct effect"). Naturally occurring examples are quartz, rochelle salt, topaz, and even cane sugar. Not all that much deformation is required, either. Lead zirconate titanate crystals, for example, will generate measurable piezoelectricity when deformed by as little as 0.1 percent. In addition, when an electric current is applied to the materials they will undergo deformation as a result (the "converse effect").

In any event, Innowattech has developed a special breed of piezoelectric devices — dubbed Innowattech Piezoelectric Generators (IPEGs) — that are designed to harvest wasted energy from moving vehicles. Last year, the company introduced a version designed to be embedded just below the surface of asphalt highways to tap into the energy of cars and trucks. One might suppose that it would be a parasitic process; after all, if it involved increased deformation of the roadway, it would take a bit more energy to propel the vehicles. The company insists, however, that IPEGs do not increase asphalt deformation and thus do not increase fuel consumption in vehicles traveling over it.

The latest twist on the concept is applying it to railroad tracks. Working with Israel's National Railway Company, Innowattech has replaced 32 existing railroad pads with their own electricity-generating ones in a test. Preliminary results suggest that if a particular section of track handles between 10 and 20 ten-car trains per hour, this will produce 120 kWh during the same period. This can be used to help power trains or signals, or can be routed to the power grid for general purposes. The company also offers pedestrian tiles for use in places like train stations, subways, shopping malls, and so forth, and a product to be placed in factories that use heavy press machinery. No information about the cost was provided, so the return on investment is still an open question. The installations have no moving parts and are rated to work for about 30 years, so the long-term numbers could be favorable. ▲

■ Innowattech's piezoelectric railway pads can produce up to 120 kWh of power.



### KILLER LASER TECHNOLOGY

You're probably familiar with zinc oxide as an additive in things like plastics, ceramics, cement, skin creams, and so on. But how about making lasers out of it? Apparently, some folks at the University of California, Riverside's Bourns College of Engineering ([www.engr.ucr.edu](http://www.engr.ucr.edu)) have figured out a way to do it, with killer results — literally. Because the devices — being constructed from ZnO nanowires — are very small and emit short-wavelength ultraviolet light, they might be useful for killing viruses, among other functions.

According to Prof. Jianlin Liu, researchers have spent a decade or so trying to find a replacement for UV semiconductor diode lasers based on gallium nitride, as they are expensive and difficult to manufacture. Zinc oxide has long been considered a good candidate except for one little problem: the material was well suited to act as the n-type diode element but couldn't work as the p-type one. However, Liu and associates solved the problem by doping the ZnO with antimony, transforming it into a p-type material. When you connect the two, you get a p-n junction diode which emits laser light from the ends of the nanowires.

Because the devices emit wavelengths down in the 340 nm range, they may provide for two or three times greater storage capacities for DVDs. And because the nanowires are so thin, it may be possible to poke one into a living cell and use the laser beam to kill unwanted cells or viruses, or even change the nature of the cell.

As usual, more research is needed, specifically in terms of the p-type material's reliability. Liu believes, "This discovery is likely to stimulate the whole field to push the technology further." ▲

# COMPUTERS AND NETWORKING

## JAPAN UP, CHINA DOWN

Just last November, China's Tianhe-1 unceremoniously stripped the Cray XT5 Jaguar of its status of the world's fastest supercomputer, logging a sustained computing speed of 2.507 PFlops/s. However, it has now bowed to the Fujitsu-RIKEN K computer which — even though not yet completed — has demonstrated a LINPACK benchmark performance of 8.162 PFlops/s. The K computer has thereby achieved the dominant spot in the list maintained by **TOP500.org**.

A Japanese machine has not held that title since 2004, when its Earth Simulator machine was top dog. The K currently employs 627 computer racks running a total of 68,544 SPARC64 VIIIx CPUs each with eight cores, giving it nearly twice as many cores as any other TOP500 system. The ultimate goal is to scale it up to 800 racks and 10 PFlops/s performance.

Interestingly, the K does not use any graphics processors

■ The Fujitsu-RIKEN K computer will eventually employ 800 of these racks, each containing about 100 CPUs.

or other accelerators, and is one of the most energy efficient machines on the list. Also noteworthy is that — for the first time ever — all of the top 10 systems achieved petaflop/s performance.

The Tianhe-1 — currently in second place — had no other challengers, and the Cray Jaguar came in third. Just barely hanging in at the number 500 spot was an IBM BladeCenter HS22 Cluster producing a paltry 10.664 GFlops/s. ▲

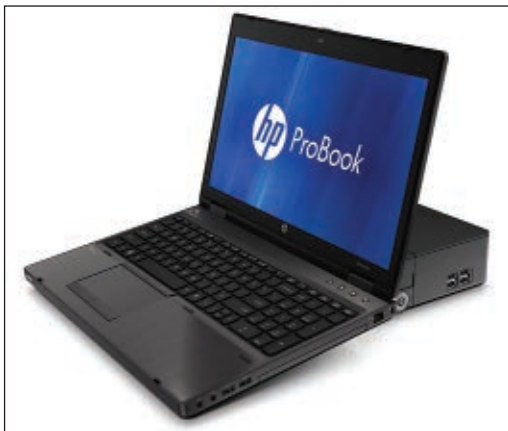

■ HP's ProBook 6465b, featuring an AMD A-series accelerated processing unit.

running between 2.3 and 2.5 GHz, and Radeon graphics running between 1.4 and 2.1 GHz. ▲

## HP OFFERING NEW AMD LINE-UP

The news for AMD aficionados out there is a fresh line-up of laptops from HP ([www.hp.com](http://www.hp.com)) utilizing the A-series (Llano) accelerated processing units which combine CPU cores and discrete graphics on a single silicon die, much like Intel's Sandy Bridge chips. Space doesn't allow a detailed description of all 11 models in the series, but the three G-series Pavilion models (starting at \$450) are budget machines, whereas the three Pavilion DVs are designed for entertainment and have enhanced graphics capabilities. The ProBook machines, starting at \$519, are business-level laptops featuring AMD VISION Pro technology and are geared to run major multimedia applications. Browser performance is enhanced by offloading Flash video to be handled by the graphics processor instead of the CPU.

All support 8 GB of RAM and 750 gigs of HD storage, and all come with USB 3.0 and Windows 7. They feature dual- and quad-core chips

## DOCK YOUR DRIVES

A quick look around the office reveals at least three older internal hard drives being used primarily as paperweights. When they were removed to make way for bigger, faster drives, I didn't list them on eBay as they're essentially worthless. However, I didn't throw them out, because (a) they might hold important information (emphasis on might); (b) I might need a spare someday (yeah, right); and (c) I was raised by people who never threw anything away unless it was worn out.

If you are in a similar situation, take a look at the StarTech ([www.startech.com](http://www.startech.com)) line of hard drive docking stations. The latest models are the SATDOCK4U3E and SATDOCK4U2E, both of which enable users to access up to four SATA drives at the same time. The main difference is that the former supports USB 3.0 and eSATA connections, but the latter only goes up to USB 2.0. Both support 2.5- and 3.5-inch units, and feature independent power and eject buttons for hot-swapping. The downside is that they list for \$190 which is probably more than all four drives are worth. If you don't need four slots, you can get twin or single stations for as little as \$32. ▲



■ Park up to four stray internal drives in a StarTech docking station.

## CIRCUITS AND DEVICES

### CELL PHONE FOR ACTIVE LIFESTYLE

There are a lot of phones to choose from these days, but if you are an outdoor adventurer, Navy Seal, or just plain clumsy and accident prone, consider the Casio G'zOne Commando™ available through Verizon Wireless ([www.verizonwireless.com](http://www.verizonwireless.com)). The Android-powered Commando offers high security features for secure email, Wi-Fi for Web access, and XT9 and T9 trace inputs to simplify text entry.

Perhaps most importantly, it's designed to withstand extreme environments, meeting MIL-STD-810G specs for immersion, rain, shock, dust, vibration, salt fog, solar radiation, altitude, and temperature. It also includes a five megapixel camera, stereo Bluetooth, and a GPS, plus Triple Sensor technology that provides information on direction, acceleration, and temperature. You can pick one up (and drop it from five feet if you want) for \$200 with a two year agreement. ▲

■ Casio's G'zOne Commando smartphone in Earth Compass mode.



### STUFF YOUR BIG BELLY WITH GARBAGE

It's tough to make anything these days without a microprocessor, and the phenomenon has even spread to trash cans. BigBelly Solar, Inc. ([www.bigbellysolar.com](http://www.bigbellysolar.com)), recently announced the sale of its 10,000th waste and recycling station, purchased by the Los Angeles Community College District (LACCD). The district bought 75 of the solar powered waste and recycling kiosks in 2009, and liked them so well that they now have deployed more than 200 of them across nine campuses.

■ The BigBelly solar powered trash station holds up to 150 gal of refuse.



According to the company, "The BigBelly intelligent waste collection system combines onsite, solar powered compaction, efficient recycling solutions, and wireless monitoring and management capability to dramatically reduce waste collection requirements. That means fewer trips are needed to collect and transport the material – which reduces fuel consumption and greenhouse gas emissions."

The units employ wireless monitoring and notification to provide status updates to a Cloud-based dashboard, allowing staff to optimize collections. Because the containers can compress and hold about five times as much trash as standard cans (up to 150 gal), collection frequency has been cut by a reported 70 to 80 percent. Apparently, the units are especially popular with educational institutions; the company says about 150 colleges and universities in the USA, Canada, and Europe have adopted them. For a largely sophomoric video, visit [www.laccdbuildsgreen.org/mediacenter/swf/flvideo/html/big-belly.php](http://www.laccdbuildsgreen.org/mediacenter/swf/flvideo/html/big-belly.php). ▲

## INDUSTRY AND THE PROFESSION

### APPLE TAKES BIGGEST SEMI BITE

The stats are in, and Apple beat out Hewlett-Packard in 2010 as the world's largest consumer of semiconductors. Apple bought \$17.5 billion worth of chips, a 79.6 percent increase over the previous year. This was primarily driven by the success of the iPhone and iPad which suck up huge amounts of NAND Flash memory. In fact, more than 60 percent of Apple's semi budget went for wireless products. In contrast, second place chip purchaser HP devoted 82 percent of its spending to computer products which has been a much weaker market. HP laid out \$15.2 billion to grab the number two spot, followed by Samsung at \$13.9 billion. ▲

# INDUSTRY AND THE PROFESSION *CONTINUED*

## Z3 TURNS 70

There has long been some dispute about what constitutes the first true computer, but one of the leading contenders is Konrad Zuse's Z3, completed in Berlin in 1941. A descendent of the Z1 — built from 1936 to 1938 — it was a highly secret project of the German government, conducted under the auspices of the Reich Air Ministry. The electromechanical Z3 is widely regarded as the first working programmable, fully automatic computing machine, although it did lack a conditional branch operation. It was built with 2,000 relays and chugged along at a clock frequency of 5.3 Hz. This allowed it to perform an addition operation in about 0.8 sec and multiplication in about 3 sec. It had a data memory of 64 words with a length of 22 bits. Programming and data were stored on punched film.

Reportedly, the German Aircraft Research Institute used the Z3 for statistical analysis of wing flutter. Ironically, when Zuse asked the German government for

funding to replace the relays with fully electronic switches, it refused, saying that the machine was "not war-important." The original was destroyed in 1943 during an Allied bombardment, but a replica was built in the 1960s. **NV**

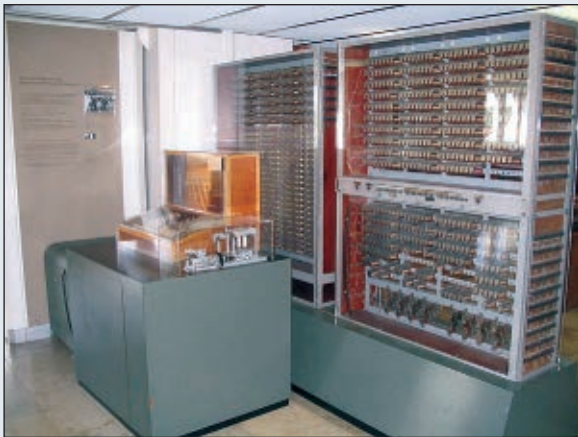

■ The Zuse Z3 replica on display at the Deutsches Museum in Munich.

## DIY NEVER HAD A BETTER FRIEND...

PanaVise® features a wide variety of high-quality & versatile vises & accessories. All designed around our patented "split ball" design, which allows for positioning your work on three planes.

**Tilt, Turn & Rotate** your work all from a single knob.

**PANA VISE®**  
Innovative Holding Solutions

7540 Colbert Drive  
Reno, Nevada 89511

**1 (800) 759-7535**

[www.PanaVise.com](http://www.PanaVise.com)

HOBBIES • ELECTRONICS • ARTS & CRAFTS • HOME REPAIR • JEWELRY • MODELS • WOOD WORK



Model 201



Model 209



Model 301



Model 350

# ELECTRONIX EXPRESS

Visit Our Website At  
<http://www.elexp.com>

**RSR™ 3MHZ SWEEP FUNCTION GENERATORS**  
6 Waveform Functions, Int/Ext Counter, lin/log sweep

**MODEL FG-30** (No Digital Display) \$135<sup>00</sup>

**MODEL FG-32** (5 Digit Display) \$195<sup>00</sup>

**INSTEK™ OSCILLOSCOPE**  
**MODEL GOS-620**  
Dual Channel - 20MHZ (INCLUDES PROBES)

**DC POWER SUPPLIES**

**MODEL HY3003 - DIGITAL DISPLAY**  
Variable output, 0-30 VDC, 0-3 Amp \$95<sup>00</sup>

**MODEL HY3003-3 - TRIPLE OUTPUT**  
Two 0-30 VDC, 0-3 Amp variable outputs plus 5V 3A fixed. Digital Display. \$184<sup>00</sup>

**Weller® SOLDERING STATION**  
#1 BEST SELLING \$39<sup>99</sup>

**MODEL WLC 100**  
0603WLC100

**ROTARY TOOL KIT** \$35<sup>95</sup>

Variable speed tool (37,000 RPM) with accessory kit in a hard plastic carry case. #29DR101

**BENCH DMM WITH RS232 INTERFACE**  
**MODEL DM9803R**  
True RMS, digital and bar graph display, AC/DC Cap, Res, frequency functions. Includes software, AC or DC operation. \$139<sup>95</sup>

**MODEL GOS-620**  
\$305<sup>00</sup>

**DIGITAL MULTIMETER**  
32 Ranges - 3 1/2 Digit  
**MODEL MY-64** \$33<sup>95</sup>  
AC/DC Volt/Current, Res. Cap., Frequency. Rubber Holster Included

**ALLIGATOR LEADS**  
SET OF 10 \$3<sup>50</sup>

**SOUND SENSOR CAR**  
REQUIRES SOLDERING  
Reverses direction whenever it detects noise, or touches an obstacle. \$9<sup>95</sup> #3221881

**RSR™ HIGH PERFORMANCE 3-WIRE IRON** \$6<sup>50</sup>  
#060509

SWITCHES	1-9	10+
8 POS DIP (V17DIP8SS)	.90	.85
Toggle Mini SPDT (17TOGSD-M)	1.40	1.20
Toggle Mini DPDT (17TOGDD-M)	\$1.55	1.35

POTENTIOMETERS	1-9	10-99	100+
Cermet (STS Series)	85¢	75¢	65¢
Multiturn (MTT Series)	85¢	75¢	55¢
Panel Mount (PMA Series)	\$1.15	80¢	70¢

Standard Values Available

**RSR™ DIGITAL SUPER ECONOMY MULTIMETER** \$6<sup>50</sup> 10+  
**MODEL 820B**  
1-9 ..... \$7.50  
#01DM820B

**MORE Low-Priced Items In Our FREE 350+ Page Catalog**

TERMS: Min. \$20 + shipping. School Purchase Orders, VISA/ MC, Money Order, Prepaid. NO PERSONAL CHECKS, NO COD. NJ Residents: Add 7% Sales Tax.

In NJ: 732-381-8020  
FAX: 732-381-1006

900 Hart St • Rahway, NJ 07065  
**800-972-2225**

<http://www.elexp.com>  
email: [electron@elexp.com](mailto:electron@elexp.com)

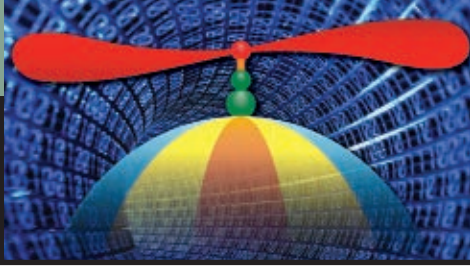

■ BY JON WILLIAMS

# SERVING UP SERVO CONTROL

You can't swing a soldering iron around the pages of *Nuts & Volts*, *SERVO Magazine*, or any other electronics magazine without bumping into a gaggle of advertisements and articles about servo controllers. And, why not? Servos have become ubiquitous in animatronics and robotics at the hobbyist level and all the way up to the pros. I don't know who created the first servo controller, but I'm pretty sure that Scott Edwards and his products popularized the concept with his mini SSCs (serial servo controller), especially back in the days when the BASIC Stamp was about the only friendly controller in town.

In concept, a servo controller is a slave processor that manages connected servos by providing regular position updates (more on this below), relieving the host processor of that burden. Most servo controllers use a serial connection to receive commands from the host. The host sends a short message to the servo controller detailing which servo to move and to where. Advanced features include setting the rate at which the servo moves between point A and point B, and even the ability to specify a move time where the rate of movement is determined by

the size of the move and the desired timing.

With 28 available pins (I tend not to count the programming/debug and EEPROM pins), Propeller projects often have plenty of I/O, and having eight cogs (processors) at our disposal means there's usually brainpower to spare, too. Of course, the Propeller can use a standard serial servo controller, but if we have the pins we might as well trade a serial cog for a custom servo control cog. What about when we need a special feature? No problem! It's just a small matter of programming.

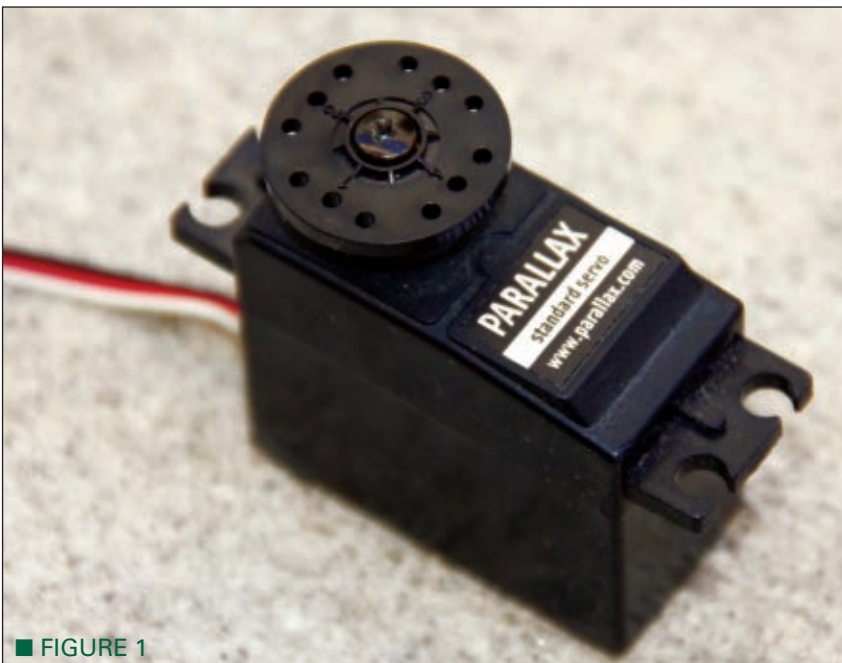

■ FIGURE 1

## SERVO CONTROL BASICS

For the two of you that didn't skip over this section, I want to clarify that the kind of servo I'm referring to is the small, specialized gear-motor that many know from RC aircraft and cars; a typical servo is shown in **Figure 1**. Inside the servo is a small motor, a gear-train to the output shaft, and connected to that is a potentiometer and feedback circuit that allow the output shaft to be moved to

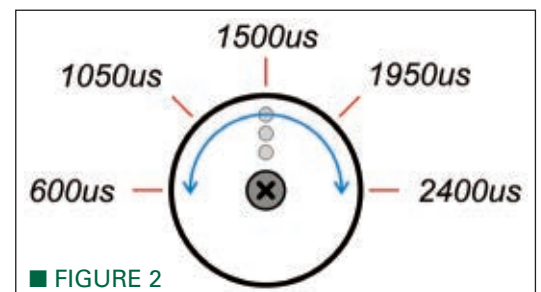

■ FIGURE 2

an angular position defined by an input pulse from the servo controller. **Figure 2** shows the position of the output shaft relative to the input



position pulse width (which is expressed in microseconds).

The servo is connected to its host with a three-pin female connector (**Figure 3**) that mates with a male header (square post header on 0.1" centers) on the servo controller. The white (or yellow) wire carries the control signal; the red is the supply voltage (typically 4.8 to 7.2 volts); and black is ground. If a project separates the controller supply from the servo supply, the grounds must be connected.

To move the servo to a desired position, a command pulse of the required width is placed on the signal line by the servo controller; this position pulse is typically refreshed every 20 milliseconds (50 times per second) as shown in **Figure 4**. That last part tends to catch BASIC Stamp users by surprise, and can complicate simple BASIC programs; I believe this is what led to the birth and popularity of the serial servo controller.

## PROPELLER POWERED SERVO CONTROL

Most applications — particularly in robotics — will, in fact, require the ability to control more than a single servo. A trick that my friend John Barrowman (not the English actor) taught me is to "walk" the servo outputs. This trick simplifies the software in that only one timer is required, versus one timer for each simultaneous output. Another benefit is that the small delay between command pulses gives the power supply a bit of a reprieve from the current surge when a servo starts moving. It's easier for the supply to deal with one servo surge load versus many.

**Figure 5** is a visual representation of the signals from a four-channel servo controller that walks the outputs. Note that when the pulse from channel 1 is finished, the pulse from channel 2 can start. This process works its way through all the channels within the servo frame timing of 20 milliseconds.

Now that we know the process, let's have a look at how to tackle it using the unique capabilities of the Propeller. To start, the virtual controller is going to run inside a synchronized loop. You may remember from my last column that a synchronized loop looks like this:

```
sync := cnt
repeat
    ' code

waitcnt(sync += constant(20 * MS_001))
```

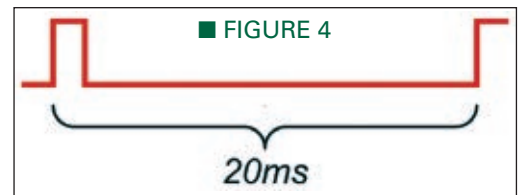

For review, just before entering the **repeat** loop, we capture the current value of the system counter. At the end of the loop, we execute a **waitcnt** instruction that updates the value in **sync** such that the loop will restart 20 milliseconds after it started — regardless of what the code between those two points is doing. The only caveat is that the loop code must consume less than 20 ms; if the loop code is too long, we'll miss the **waitcnt** target and will have to wait for **cnt** to wrap back around it (about 58 seconds later!).

As with the motor controller we did last time, we're not going to generate the output pulse through direct pin manipulation. We will employ one of the cog's counters to do the heavy lifting for us. By setting the counter to PWM/NCO mode, we can move the pulse width into the counter's phase accumulator and the rest takes care of itself (please see my July '11 column for details on using the counters in PWM/NCO mode).

Assuming a global array to hold the servo position values (which are expressed in microseconds), we can construct a simple walking servo controller like this:

```
pri servo8(count, base) | frame, idx

    count := 1 #> count <# 8

    outa := 0
    dira := ($FFFF_FFFF >> (32 - count)) <<
base

    frqa := 1
    phsa := 0

    frame := cnt
    repeat
        repeat idx from 0 to (count-1)
            ctra := (%00100 << 26 ) | (base + idx)
```

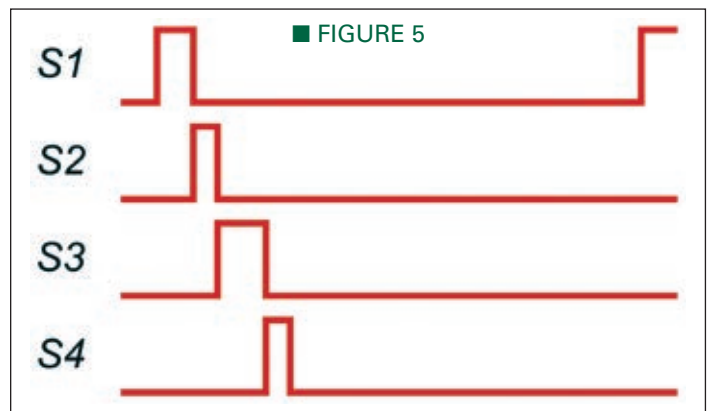

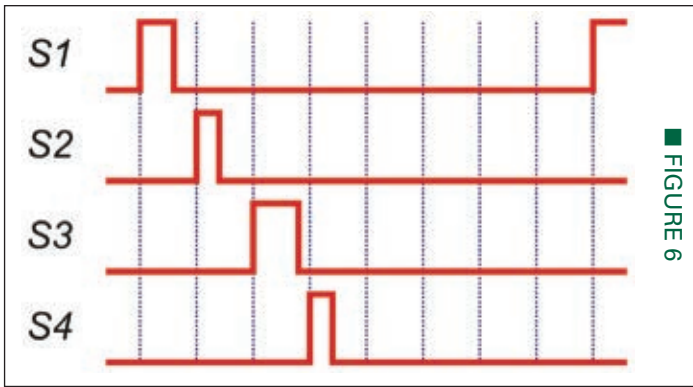

■ FIGURE 6

```

phsa := -(pos[idx] * US_001)
waitpne(|< idx, |< idx, 0)
waitpeq(|< idx, |< idx, 0)
ctra := 0
waitcnt(frame += constant(20 * MS_001))

```

Yes, that's it. This method – which is designed to be run in its own cog – will generate position pulses for up to eight servos with one microsecond position resolution, and nary a line of Assembly code required! Pretty cool, huh?

Starting at the top, the code forces the value in *count* (the number of servos we want to control) into the legal range. The maximum value of eight is not arbitrary; with a possible pulse width of 2,400 microseconds (2.4 ms), eight servos is the most we can squeeze into the 20 ms servo frame.

The next step is to configure the output pins. This is required because the method will run in its own cog and each cog has its own pin direction register. As discussed last time, we do need to ensure that no other cog is making any of the target servo pins high. All cog's outputs are OR'd together so any cog can make any I/O pin go high, regardless of the state of other cogs. In order to prevent interference with non-servo cogs, the output mask is created for the number of servo pins in *count*; these outputs must be contiguous. The mask for the servo pins is created by shifting \$FFFF\_FFFF (all bits set to 1) right by 32, minus the number of servo channels. What we're left with is a value with "count" 1s in it. This value is then shifted left to align the LSB with the specified *base* pin (the first channel of our servo controller) and then is written to the **dira** register.

The frequency and phase registers for the counter are preset to allow precise timing and prevent a start-up glitch; then we drop into the control loop. A loop within the loop

▶ BILL OF MATERIALS		
Item	Description	Supplier/Part No.
Rx	100 ohms	Mouser 299-100-RC
Cx	0.01 μF	Mouser 80-C315C103M5U
Xx	0.1 male	Mouser 517-6111TG

iterates through the number of servo channels, setting the counter PWM/NCO mode and then using the current channel pin. The pulse is, in fact, generated by setting the phase register to the negative value of the pulse width (this value is expressed in **cnt** ticks). At this point, the pulse is underway and we don't have to do anything else. That is, it will end on its own (when the value in the phase accumulator reaches zero).

The next two lines monitor the pin; first to go high (start of the pulse), then to go low (end of the pulse). When the pulse is finished, the counter is reset and the next channel pulse is generated. When all channels are complete, the final **waitcnt** (in the outer loop) finishes the servo frame timing.

Yes, it really is that simple. By using the counter to generate the servo pulses instead of sitting on a **waitcnt** instruction, we're left with a lot of useful time between servo channels. We can use this time to modify the servo position value for advanced control techniques.

Before we get to that, though, have a look at **Figure 6**; this illustrates a modified walking strategy that places each servo channel (again, up to eight) in its own slot. The reason for this comes from my friend Peter, a Hollywood visual effects expert who has forgotten more about motion control than I'll ever know (see his servo controlled characters at [www.socalhalloween.com](http://www.socalhalloween.com)).

While discussing servo programming over lunch, he expressed concern that the simple walking algorithm allows for a wobble in frame timing for servo channels 2 through 8. The reason for this is that the leading edge of a servo follows the falling edge of the previous, and the timing of the previous servo pulse can change. Channel 1 is not affected as it always starts at the beginning of the 20 ms servo frame.

My adjustment is simple: Divide the 20 ms frame into eight, 2,500 μS slots. A servo pulse is generated at the start of a slot; hence, leading-edge-to-leading-edge timing for every slot is always 20 ms – no wobble. Another benefit is that we now have almost 2.5 ms to manipulate the position value for a servo channel before the next slot starts. This is an eternity – even for a high level language like Spin.

Let's have a look at the modification which runs each servo channel in its own slot:

```

slot := cnt
repeat
  repeat idx from 0 to 7
    if (idx < count)
      ctra := (%00100 << 26 ) | (base +
idx)

      phsa := -(pos[idx] * US_001)
      waitcnt(slot += constant(2_500 *
US_001))
      ctra := 0

```



As you can see, overall timing is now controlled by the inner loop which runs eight times. If the inner loop index is less than the servo count, a pulse for the channel is generated. The slot timing is executed as usual with **waitcnt**, even if there is no pulse generated for that slot (i.e., when we're controlling fewer than eight channels) to maintain the 20 ms servo frame.

Since we've got almost 2.5 ms to work with during a slot, let's put that time to work. A popular feature with modern servo controllers is setting the servo speed for movement to the desired position. To facilitate this feature, we'll need two additional values per channel: 1) the new target position; and 2) the number of microseconds to change during each servo frame:

```

slot := cnt
repeat
  repeat idx from 0 to 7
    if (idx < count)
      ctra := (%00100 << 26 ) | (base +
idx)
      phsa := -(pos[idx] * US_001)
      if (pos[idx] < target[idx])
        pos[idx] := {
          } (pos[idx] + delta[idx]) <#
target[idx]
      elseif (pos[idx] > target[idx])
        pos[idx] := {
          } (pos[idx] - delta[idx]) #>
target[idx]
      waitcnt(slot += (2_500 * US_001))
      ctra := 0

```

Allowing for speed control is very straightforward. After the pulse has started, we check to see if the current position (in *pos*) differs from the intended destination (in *target*). If these values differ, the position is adjusted by the channel change value (in *delta*) toward the destination. The max (<#) and min (#>) operators prevent over- or under-shoot of the destination position.

I'll be the first to admit that I "liberate" good ideas from wherever I find them, so when I saw the speed feature in a popular servo controller, I duplicated it. It works by allowing us to express the servo speed in microseconds (position change) per second. With 50 updates per second, the **set\_pos()** method call that sets the new *target* and *delta* values is as follows:

```

pub set_pos(ch, newpos, speed)

if (ch => 0) and (ch <= 7)
  newpos := SVO_MIN #> newpos <# SVO_MAX
  target[ch] := newpos
  if (speed = 0)
    delta[ch] := 0
    pos[ch] := newpos
  else
    delta[ch] := (speed / 50) #> 1

```

This method sets the *target* position to *newpos* (which has been validated) and then looks for a speed setting of greater than zero. If we want the servo to move to *target* at its normal rate, we set *speed* to zero; doing this sets the current position value to *newpos*. Non-zero speed values are divided by 50 (frames per second) and moved into *delta*. This is the value that we use to update the current servo position while moving to the destination.

Assuming a 180 degree servo and the lowest speed setting (1 to 50), the servo will move from one extreme to another in about 36 seconds. To make the servo move any slower would require modifications to the code that I don't think add benefit, but if you think I'm wrong please update the code and send it my way. I'm just finally getting really involved in servo control, especially as Halloween and Christmas are approaching – I have lots of fun animatronics ideas.

With speed control of the servo, we can add another method that allows us to command a servo to move from its present position to a new position in a specific amount of time (which will be specified in milliseconds). Have a look at the **move\_to()** method:

```

pub move_to(ch, newpos, ms) | frames, move

if (ch => 0) and (ch <= 7)
  newpos := smin #> newpos <# smax
  frames := ms / 20
  move := |(newpos - pos[ch]) * 10 /
frames
  move := ((move + 5) / 10) #> 1
  if (frames < 2)
    pos[ch] := newpos
    target[ch] := newpos
  else
    target[ch] := newpos
    delta[ch] := move

```

This method works by calculating the number of servo frames required for the timing specified in the *ms* (milliseconds) parameter. It also calculates the frame-to-frame move (*delta*) that accommodates the timing for this distance traveled. If more than one frame is required by the move, the *target* and *delta* values are updated. Otherwise, the move is immediate.

Before we finish, let me just suggest that it's not a good idea to connect a microcontroller I/O pin directly to the signal line to the servo. The servo contains a motor and active electronics that can generate noise on this line. Many will simply put a resistor in series with the signal line; I tend to use a small RC circuit suggested by John. He was doing some work with noisy servos and found that an RC circuit using 100 ohms and 0.01 µF cleaned up the noise without degrading the signal pulse. You can leave out the cap if you want, but don't leave out the resistor. **Figure 7** shows the connections between the I/O pin and the three-pin servo header.



**POSCOPE MEGA1+**



.....it's oscilloscope.....  
 .....it's spectrum analyzer.....  
 .....it's dataloger.....  
 .....it's recorder.....  
 .....it's logic analyzer.....  
 .....it's pattern generator.....  
 .....it's signal generator.....

**POKEYS**

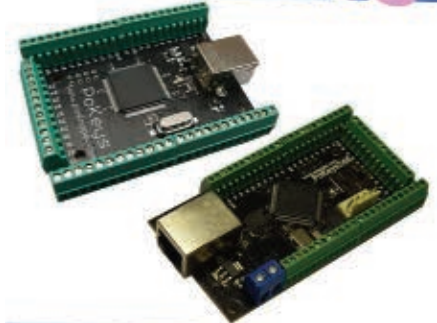

.....it's keyboard emulator.....  
 .....it's joystick emulator.....  
 .....it's USB or Ethernet.....  
 .....it's ModBus and TCP.....  
 .....can drive LCDs, LED matrixes.....  
 .....can read encoders, keyboard matrixes.....  
 .....can handle more than 300 IOs.....  
 .....matlab, Labview, C#, VB.NET, VB6.0 and Delphi examples.....

[www.poscope.com](http://www.poscope.com)



■ FIGURE 7

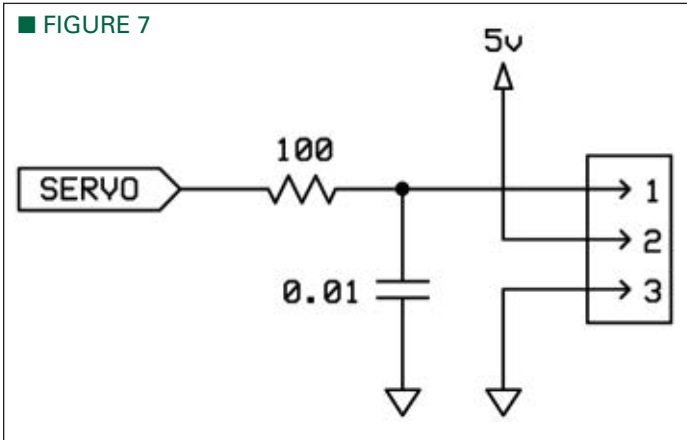

Download the project code (which bundles everything discussed here into a reusable object) and have a look at the rest. You'll see that I've also added methods to set the position and move the speed of all the servos with a single call. Another method allows us to wait until a specific servo channel reaches its intended target.

For me, anyway, this is just a start. Having the ability to create servo pulses with 1  $\mu$ S resolution and enough time between servo pulses to add speed control features using high level code (Spin) means that the Propeller is likely to become a very serious player in the servo control arena — especially for those projects that have available I/O. For those of you that don't want to roll your own hardware but would like a custom servo controller, you can always get a Propeller PSC from Parallax and reprogram it. With the code we've developed here, you're well on your way. Here's a hint for controlling the other eight outputs on the PPSC: Each cog has two counters. Use the second counter to generate pulses for the second set of eight outputs. This keeps the servo pulse generation in a single cog.

## GOOD NEWS FOR ARDUINO FANS

While working on a lighting project in a Hollywood prop shop, I was approached by a member of the crew who asked if the Propeller platform I was using was an

Arduino. It's understandable. The marketing machine behind the Arduino is doing a great job, and I designed the Propeller platform to be stackable like the Arduino.

When I told him about the Propeller, he was

interested but not enough to give up his investment in Arduino "shields." Well, good news: You can use those shields with the Propeller — the Propeller ASC (Arduino Shield Compatible) from MGH Designs, that is. As you'd expect, the Propeller ASC is a small board, the same size and layout (including the odd header spacing) as a traditional Arduino. An on-board ADC handles the analog input pins.

I have nothing against the Arduino but having worked with one, I find the Propeller easier to program and far more powerful. If you're an Arduino user that's been wanting to give the Propeller a go, now you can. I'm pretty certain you'll be happy for doing it.

Until next time, keep spinning and winning with the Propeller! **NV**

**JON "JONNYMAC" WILLIAMS**

[jwilliams@efx-tek.com](mailto:jwilliams@efx-tek.com)

**PARALLAX, INC.**

[www.parallax.com](http://www.parallax.com)

**GADGET GANGSTER**

Propeller platform kits and accessories

[www.gadgetgangster.com](http://www.gadgetgangster.com)

**MGH DESIGNS**

Propeller ASC

[www.mghdesigns.com](http://www.mghdesigns.com)

# Same circuit. Same tools.

# Your choice.

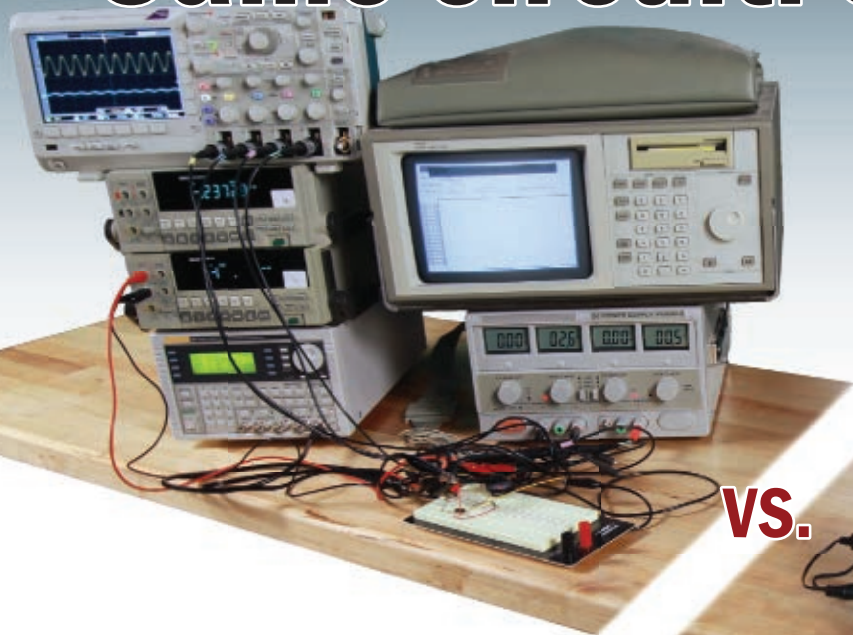

VS.



## ELECTRONICS EXPLORER™

### Integrated Analog/Digital Circuit Design Station

4-channel, 40MSa Oscilloscope  
4-channel voltmeter

2 programmable reference voltages

2-channel Arbitrary Waveform Generator

Triple-Output Power Supply (two programmable)

32-Channel Logic Analyzer

32-Channel Pattern Generator

Discrete digital I/O's (buttons, switches, LEDs, etc)

The Digilent Electronics Explorer™ board (EE board) is a complete, all-in-one circuit design station that can turn any PC into a powerful test and measurement system. It combines everything needed to build and test analog and digital circuits into a single, simplified product: a large solderless breadboard, three programmable power supplies, and six test and measurement devices, all accessed using simple jumper wires. The free PC-based WaveForms™ software drives EE Board's high-speed USB2 port to create a powerful, high-bandwidth test and measurement system that responds in near real-time.

The waveform generators support standard and custom waveforms with sweeps, envelopes and modulation. The scope channels offer real-time FFTs, complex math functions, complete cursor and measurement features, and X-Y plots. The digital pattern generator and logic analyzer offer all the standard features and include cross-triggering with the analog instruments. The power supplies include full current and voltage control, and can be actively driven from the waveform generators to create new and interesting stimulus not possible with conventional equipment. These impressive features, together with real-time Bode plots, connection to a PC's sound system, and a host of other features create a truly remarkable piece of equipment.

Now you can quickly and easily build and test analog circuits right on the desktop, and change forever the way you approach analog design.

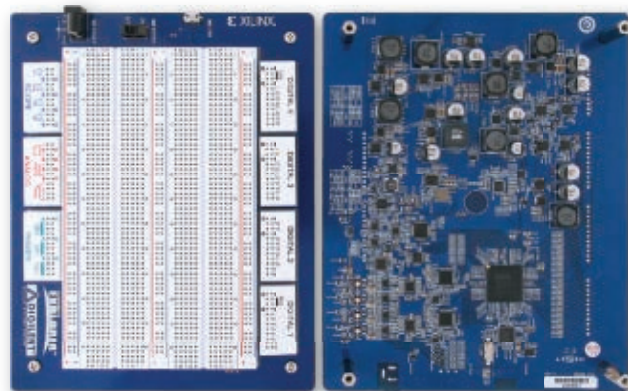

# \$399

(Academic)

## Complete System!

Includes EE Board + Software



(509) 334-6306 [www.digilentinc.com](http://www.digilentinc.com)

# Back To School Time!

## Build It, Learn It, Achieve It, and ENJOY

### Electrocardiogram ECG Heart Monitor

- ✓ Visible and audible display of your heart rhythm!
- ✓ Bright LED "Beat" indicator for easy viewing!
- ✓ Re-usable hospital grade sensors included!
- ✓ Monitor output for professional scope display
- ✓ Simple and safe 9V battery operation

September means it's time for the kids to head back to school. You can get kids of all ages ahead of the learning curve and excited about science, health, and electronics with the ECG1C from Ramsey! Not only will putting it together teach them about building their own electronics, but the completed kit is a hands on demonstration of the relationship between electrical activity and the human body. Each time the human heart beats, the heart muscle causes small electrical changes across your skin. By monitoring and amplifying these changes, the ECG1C detects the heartbeat and allows you to accurately display it, giving you a window into the inner workings of the body!

Use the ECG1C to astound your physician with your knowledge of ECG/EKG systems. Enjoy learning about the inner workings of the heart while, at the same time, covering the stage-by-stage electronic circuit theory used in the kit to monitor it. The three probe wire pick-ups allow for easy application and experimentation without the cumbersome harness normally associated with ECG monitors.

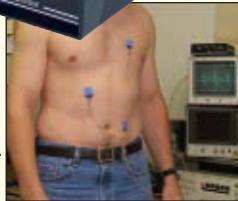

One of our engineers/guinea pigs, checking his heart!

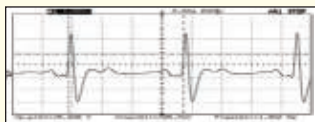

The documentation with the ECG1C covers everything from the circuit description of the kit to the circuit description of the heart! Multiple "beat" indicators include a bright front panel LED that flashes with the actions of the heart along with an adjustable level audio speaker output that supports both mono and stereo hook-ups. In addition a monitor output is provided to connect to any standard oscilloscope to view the traditional style ECG/EKG waveforms just like you see in a real ER or on one

of the medical TV shows! See the display above? That's one of our engineers, hooked up to the ECG1C after an engineering meeting! (We were all surprised it wasn't flat lined!)

The fully adjustable gain control on the front panel allows the user to custom tune the differential signal picked up by the probes giving you a perfect reading and display every time! 10 hospital grade re-usable probe patches are included together with the matching custom case set shown. Additional patches are available in 10-packs. Operates on a standard 9VDC battery (not included) for safe and simple operation. Note, while the ECG1C professionally monitors and displays your heart rhythms and functions, it is intended for hobbyist usage only. If you experience any cardiac symptoms, seek proper medical help immediately!



<b>ECG1C</b>	<b>Electrocardiogram Heart Monitor Kit With Case &amp; Patches</b>	<b>\$44.95</b>
<b>ECG1WT</b>	<b>Electrocardiogram Heart Monitor, Factory Assembled &amp; Tested</b>	<b>\$89.95</b>
<b>ECGP10</b>	<b>Electrocardiogram Re-Usable Probe Patches, 10-Pack</b>	<b>\$7.95</b>

### Pocket Audio Generator

A perfect test source for stereo line inputs on any amplifier or mixer. Provides 50Hz, 100Hz, 1kHz, 10kHz, & 20kHz tones, plus 32 bit digital pink noise. Great to help you identify cables or left/right reversals! Stereo RCA line level outputs. Uses 2xCR2025, not included.



**K8065 Pocket Audio Generator Kit \$29.95**

### Pocket Vu Meter

Hand held audio level meter that fits in your pocket! Built-in mic picks up music and audio and displays it on an LED bargraph. Includes enclosure shown. Runs on one 3V Li-Ion button cell, not included. If you ever wanted an easy way to measure audio levels, this is it!



**MK146 Pocket Vu Meter Kit \$8.95**

### Mini LED Light Chaser

This little kit flashes six high intensity LEDs sequentially in order. Just like the K8032 to the right does with incandescent lights. Makes a great mini attention getter for signs, model trains, and even RC cars. Runs on a standard 9V battery.



**MK173 Mini LED Light Chaser Kit \$15.95**

### Running Light Controller

Controls and powers 4 incandescent lights so they appear to "travel" back and forth (Like the hood on KITT!). Great for the dance floor or promotional material attention getters, exhibits, or shows. Runs on 112-240VAC.



**K8032 4-Channel Running Light Kit \$38.95**

### Digital Voice Changer

This voice changer kit is a riot! Just like the expensive units you hear the DJ's use, it changes your voice with a multitude of effects! You can sound just like a robot, you can even add vibrato to your voice! 1.5W speaker output plus a line level output! Runs on a standard 9V battery.

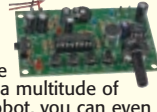

**MK171 Voice Changer Kit \$14.95**

### Steam Engine & Whistle

Simulates the sound of a vintage steam engine locomotive and whistle! Also provides variable "engine speed" as well as volume, and at the touch of a button the steam whistle blows! Includes speaker. Runs on a standard 9V battery.



**MK134 Steam Engine & Whistle Kit \$11.95**

### Laser Trip Senser Alarm

True laser protects over 500 yards! At last within the reach of the hobbyist, this neat kit uses a standard laser pointer (included) to provide both audible and visual alert of a broken path. 5A relay makes it simple to interface! Breakaway board to separate sections.



**LTS1 Laser Trip Sensor Alarm Kit \$29.95**

### Liquid Level Controller

Not just an alarm, but gives you a LED display of low, middle, or high levels! You can also set it to sound an alarm at the high or low condition. Provides a 2A 240VAC rated relay output. Runs on 12-14VAC or 16-18VDC.

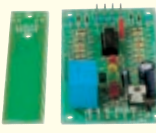

**K2639 Liquid Level Controller Kit \$21.95**

## Back To School Spotlight!



### Beginners To Advanced... It's Fun!

- ✓ Learn and build!
- ✓ 130, 200, 300, & 500 in one electronic labs!
- ✓ Practical through hole and SMT soldering labs!
- ✓ Integrated circuit AM/FM radio lab!
- ✓ Fuel Cell, Solar Hydrogen, and Bio-Energy labs!
- ✓ Beginner's non-soldering kits!

For over 3 decades we've become famous for making electronics fun, while at the same time making it a great learning experience. As technology has changed over these years, we have continued that goal!

**PL130A** Gives you 130 different electronic projects together with a comprehensive learning manual describing the theory behind all the projects.

**PL200** Includes 200 very creative fun projects and includes a neat interactive front panel with 2 controls, speaker, LED display and a meter.

**PL300** Jump up to 300 separate projects that start walking you through the learning phase of digital electronics.

**PL500** The ultimate electronics lab that includes 500 separate projects that cover it all, from the basics all the way to digital programming.

**SP3B** Whether young or old, there's always a need to hone your soldering skills. Either learn from scratch or consider it a refresher, and end up with a neat little project when you're done!

**SM200K** Move up to Surface Mount Technology (SMT) soldering, and learn exactly how to solder those tiny little components to a board!

**AMFM108K** We not only take you through AM and FM radio theory but we guide you through IC's. When you're done you've built yourself an IC based AM/FM radio that works great!

**KNS10** With a reversible PEM fuel cell that combines electrolysis and power conversion into a single device you end up building your own fuel cell car! Learn tomorrow's technology today!

**KNS11** Learn alternative fuel technology while you build your own H-Racer car and refueling station!

**KNS13** Convert ethanol alcohol to run a PEM fuel cell and watch it all work in front of your eyes!

**KNS1** A great beginner's kit for the dinosaur enthusiast in the family, young and old! A wooden hobby kit that teaches motor and gear driven operation that requires no soldering.

<b>PL130A</b>	<b>130-In-One Lab Kit</b>	<b>\$39.95</b>
<b>PL200</b>	<b>200-In-One Lab Kit</b>	<b>\$69.95</b>
<b>PL300</b>	<b>300-In-One Lab Kit</b>	<b>\$89.95</b>
<b>PL500</b>	<b>500-In-One Lab Kit</b>	<b>\$219.95</b>
<b>SP1A</b>	<b>Through Hole Soldering Lab</b>	<b>\$9.95</b>
<b>SM200K</b>	<b>SMT Practical Soldering Lab</b>	<b>\$22.95</b>
<b>AMFM108K</b>	<b>AM/FM IC Lab Kit &amp; Course</b>	<b>\$34.95</b>
<b>KNS10</b>	<b>Fuel Cell Car Science Kit</b>	<b>\$82.95</b>
<b>KNS11</b>	<b>H-Racer &amp; Refueling Station Kit</b>	<b>\$144.95</b>
<b>KNS13</b>	<b>Bio-Energy Fuel Cell Kit</b>	<b>\$129.95</b>
<b>KNS1</b>	<b>Tyrannomech Motorized Kit</b>	<b>\$17.95</b>



Look for the QR tag like this throughout our catalog and print ads. Use the Tag app in your smart phone to automatically get more information for that specific product, or in this case, it will take you right to [www.ramseykits.com](http://www.ramseykits.com)!

- ✓ Build It!
- ✓ Learn It!
- ✓ Achieve It!
- ✓ Enjoy It!

## Follow Us and SAVE \$\$

Follow us on your favorite network site and look for a lot of super deals posted frequently... exclusively for our followers!



## Vintage Battery Eliminator

Collectors come across some great deals on antique battery-powered radios, but how to power them is a real problem. Many classic radios operated on batteries only, and in many cases a series of three batteries for each radio were required!

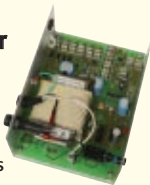

The new ABCE1 Battery Eliminator gives you an easy way to replace all these batteries with a simple household AC power connection to resurrect your vintage antique radios! Provides "A" filament, "B" plate, and "C" control grid supplies, which are all isolated from each other. Complete with aluminum case. Runs on 110-240VAC.

**ABCE1 Vintage Radio Battery Elim Kit \$199.95**

## Passive Aircraft Monitor

The hit of the decade! Our patented receiver hears the entire aircraft band without any tuning! Passive design has no LO, therefore can be used on board aircraft! Perfect for airshows, hears the active traffic as it happens! Available kit or factory assembled.



**ABM1 Passive Aircraft Receiver Kit \$89.95**

## RF Preamplifier

The famous RF preamp that's been written up in the radio & electronics magazines! This super broadband preamp covers 100 KHz to 1000 MHz! Unconditionally stable gain is greater than 16dB while noise is less than 4dB! 50-75 ohm input. Runs on 12-15 VDC.



**SA7 RF Preamp Kit \$19.95**

## Mad Blaster Warble Alarm

If you need to simply get attention, the "Mad Blaster" is the answer, producing a LOUD ear shattering raucous racket! Super for car and home alarms as well. Drives any speaker. Runs on 9-12VDC.

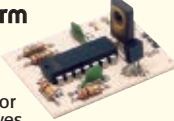

**MB1 Mad Blaster Warble Alarm Kit \$9.95**

## Water Sensor Alarm

This little \$7 kit can really "bail you out"! Simply mount the alarm where you want to detect water level problems (sump pump)! When the water touches the contacts the alarm goes off! Sensor can even be remotely located. Runs on a standard 9V battery.



**MK108 Water Sensor Alarm Kit \$6.95**

## Air Blasting Ion Generator

Generates negative ions along with a hefty blast of fresh air, all without any noise! The steady state DC voltage generates 7.5kV DC negative at 400uA, and that's LOTS of ions! Includes 7 wind tubes for max air! Runs on 12-15VDC.



**IG7 Ion Generator Kit \$64.95**

## Tri-Field Meter Kit

"See" electrical, magnetic, and RF fields as a graphical LED display on the front panel! Use it to detect these fields in your house, find RF sources, you name it. Featured on CBS's Ghost Whisperer to detect the presence of ghosts! Req's 4 AAA batteries.



**TFM3C Tri-Field Meter Kit \$74.95**

## Electret Condenser Mic

This extremely sensitive 3/8" mic has a built-in FET preamplifier! It's a great replacement mic, or a perfect answer to add a mic to your project. Powered by 3-15VDC, and we even include a coupling cap and a current limiting resistor! Extremely popular!



**MC1 Mini Electret Condenser Mic Kit \$3.95**

## Four-Mode Keyless Entry Test Set

Just like the days of "plugs, points, and condenser" are over, so are the days of having the hardware store grind out a spare key for your car! Now when your keyless access system doesn't work, you need to accurately detect what part of the system is malfunctioning. This could be anything from a dead battery in the key fob, a "brain-dead" key fob, to malfunctioning sensors, antennas, or other system components in the vehicle. Until now there was no way to determine where the system was failing.



Testing your system is easy. To test the complete 125 kHz/315 MHz communications path just stand close to the vehicle with the WCT3 and your key fob in hand. Press the test button and the WCT3 will detect and display the presence of the vehicle's 125kHz/20KHz signal and, if they "handshake", will also detect and display the presence of your key fob's 315MHz return signal. You can independently test key fob only signals (panic, lock, trunk, etc.) by holding the key fob near the WCT3, pressing the test button, and pushing the function button on the key fob. The same functionality testing can be done with IR key fobs. The modulated IR signal is detected and will illuminate the IR test LED on the test set. If you know a few "secrets" you can also see if the tire pressure sensors/transmitters are generating signals or the built-in garage door opener in your rear view mirror is transmitting a signal! Runs on a standard 9V battery. Also available factory assembled & tested.

**WCT3 Four-Mode Keyless Entry Test Set Kit \$59.95**

## Voice Activated Switch

Voice activated (VOX) provides a switched output when it hears a sound. Great for a hands free PTT switch or to turn on a recorder or light! Directly switches relays or low voltage loads up to 100mA. Runs on 6-12 VDC.



**VS1 Voice Switch Kit \$9.95**

## Touch Switch

Touch on, touch off, or momentary touch hold, it's your choice with this little kit! Uses CMOS technology. Actually includes TWO totally separate touch circuits on the board! Drives any low voltage load up to 100mA. Runs on 6-12 VDC.



**TS1 Touch Switch Kit \$9.95**

## Electronic Watch Dog

A barking dog on a PC board! And you don't have to feed it! Generates 2 different selectable barking dog sounds. Plus a built-in mic senses noise and can be set to bark when it hears it! Adjustable sensitivity! Unlike the Saint, eats 2-8VAC or 9-12VDC, it's not fussy!

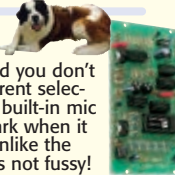

**K2655 Electronic Watch Dog Kit \$39.95**

## USB DMX Interface

Control DMX fixtures with your PC via USB! Controls up to 512 DMX channels each with 256 different levels! Uses standard XLR cables. Multiple fixtures can be simply daisy chained. Includes Light Player software for easy control. Runs on USB or 9V power.



**K8062 USB DMX Interface Controller Kit \$67.95**

## Tickle-Stick Shocker

The kit has a pulsing 80 volt tickle output and a mischievous blinking LED. And who can resist a blinking light and an unlabeled switch! Great fun for your desk, "Hey, I told you not to touch!" Runs on 3-6 VDC.



**TS4 Tickle Stick Kit \$12.95**

## USB Experimenter's Kit

Get hands-on experience developing USB interfaces! 5 digital inputs, 8 digital outputs, 2 analog I/O's! Includes diagnostic software and DLL for use with Windows based systems. The mystery is solved with this kit!



**K8055 USB Experimenter's Kit \$49.95**

## Sniff-It RF Detector Probe

Measure RF with your standard DMM or VOM! This extremely sensitive RF detector probe connects to any voltmeter and allows you to measure RF from 100kHz to over 1GHz! So sensitive it can be used as a RF field strength meter!



**RF1 Sniff-It RF Detector Probe Kit \$27.95**

## OBDII CarChip Pro

The incredible OBDII plug-in monitor that has everyone talking! Once plugged into your vehicle it monitors up to 300 hours of trip data, from speed, braking, acceleration, RPM and a whole lot more. Reads and resets your check engine light, and more!



**8226 CarChip Pro OBDII Monitor-Asmb \$79.00**

## Doppler Direction Finder

Track down jammers and hidden transmitters with ease! 22.5 degree bearing indicator with adjustable damping, phase inversion, scan and more. Includes 5 piece antenna kit. Runs on 12VDC vehicle or battery power.



**DDF1 Doppler Direction Finder Kit \$169.95**

## Retro Nixie Tube Clock

Genuine Nixie tubes popular in the 50's brought back in one of the neatest digital clocks around today! This compact unit is great to build into your own enclosure or order our custom plexiglass enclosure. Requires 12VDC 500mA.

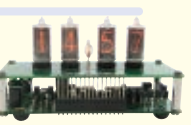

**K8099 Compact Nixie Clock Kit \$139.95**

## HV Plasma Generator

Generate 2" sparks to a handheld screwdriver! Light fluorescent tubes without wires! This plasma generator creates up to 25kV at 20kHz from a solid state circuit! Build plasma bulbs from regular bulbs and more! Runs on 16VAC or 5-24VDC.



**PG13 HV Plasma Generator Kit \$64.95**

## Speedy Speed Radar Gun

Our famous Speedy radar gun teaches you doppler effect the fun way! Digital readout displays in MPH, KPH, or FPS. You supply two coffee cans! Runs on 12VDC or our AC125 Supply.



**SG7 Speed Radar Gun Kit \$69.95**

## Broadband RF Preamp

Need to "perk-up" your counter or other equipment to read weak signals? This preamp has low noise and yet provides 25dB gain from 1MHz to well over 1GHz. Output can reach 100mW! Runs on 12 volts AC or DC or the included 110VAC PS. Assmb.



**PR2 Broadband RF Preamp \$69.95**

## 3-In-1 Multifunction Lab

The handiest item for your bench! Includes a RoHS compliant temp controlled soldering station, digital multimeter, and a regulated lab power supply! All in one small unit for your bench! It can't be beat!



**LAB1U 3-In1 Multifunction Solder Lab \$134.95**

Get the latest 2011 Ramsey Hobby Catalog today! Filled with some of the neatest goodies around! Order yours today... Or be green and download the PDF at [www.ramseykits.com/catalog!](http://www.ramseykits.com/catalog!)

**800-446-2295**  
**www.ramseykits.com**

**RAMSEY ELECTRONICS®**

590 Fishers Station Drive

Victor, NY 14564

(800) 446-2295

(585) 924-4560

Prices, availability, and specifications are subject to change. We are not responsible for typos, stupid, printer's bleed, end of summer blues or excessive emails from Robin! Possession of this ad will not guarantee you acceptance into Hgvard! Visit [www.ramseykits.com](http://www.ramseykits.com) for the latest pricing, specials, terms and conditions. Copyright 2011 Ramsey Electronics®...so there!

# Q&A

## WHAT'S UP:

Join us as we delve into the basics of electronics as applied to every day problems, like:

- ✓ Solar Controller
- ✓ DSL Carrier Detector
- ✓ Hobby Motor Speed Controller

### ■ WITH RUSSELL KINCAID

In this column, I answer questions about all aspects of electronics, including computer hardware, software, circuits, electronic theory, troubleshooting, and anything else of interest to the hobbyist. Feel free to participate with your questions, comments, or suggestions. Send all questions and comments to: [Q&A@nutsvolts.com](mailto:Q&A@nutsvolts.com)

## COMB GENERATOR REQUEST

**Q** I found your article on comb filter design to be most interesting! I would like to inquire if you might have a circuit for a comb generator? I'd like it to have equal amplitude marker signals spaced 100 KHz apart, all the way up to 30 MHz. This test generator has multiple uses for calibrating receivers, scopes, etc. Any chance that you might be able to come up with a schematic?

— Harry Weber

**A** A comb generator is made by generating narrow pulses at the comb spacing frequency. The narrower the pulse, the wider the range of the comb, but the amplitude also reduces. I arbitrarily set -60 dB as the useable

limit which puts the comb range to about 30 MHz. My circuit is in **Figure 1**. The resistors R5, R6, and R7 are to maintain 50 ohm output impedance while keeping the collector current of Q3 under the 50 mA maximum. As you may know, 30 nS is the fastest that a 2N2222 can switch. However, I found a SPICE model for a 10 GHz transistor which is Q3. Capacitor C1 provides the short turn on time for Q3; larger values will give wider pulse width and higher output but less bandwidth. **Figure 2** is the comb frequency response (fast Fourier transform) in Switcher Cad.

be redesigned to 420.455 kHz. The original filter was 200 kHz; remember that I am working with vacuum tubes.

— C. Kendrick Sellen

**A** The original design was a top coupled type with 18 pF coupling capacitors. Doubling the frequency will reduce the coupling capacitors but it should still be buildable; see **Figure 3**. The inductors are 283.6 μH and can be made by 40 turns on RadioShack 273-104 RF choke core using whatever wire you have handy that fits.

## BANDPASS FILTER REDESIGN

**Q** Recently, I asked if the bandpass filter that was published in the December '09 issue (page 25) could

## SOLAR CONTROLLER

**Q** I have only received a couple of issues of *Nuts & Volts* and enjoy your Q & A section. Therefore, I thought you might be able to help

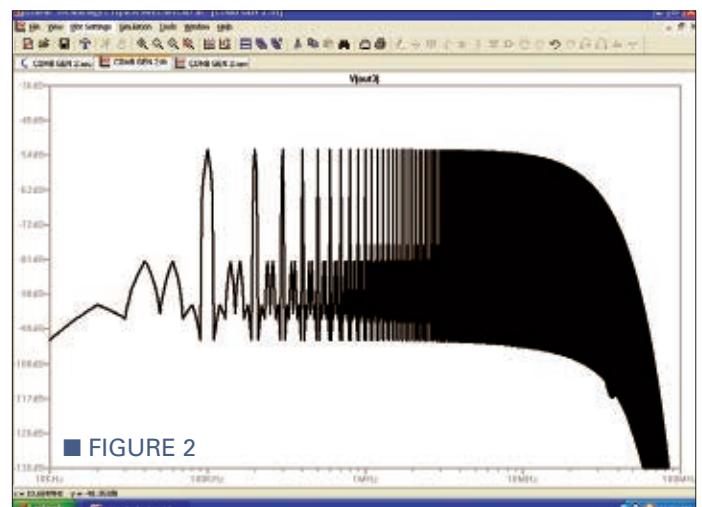
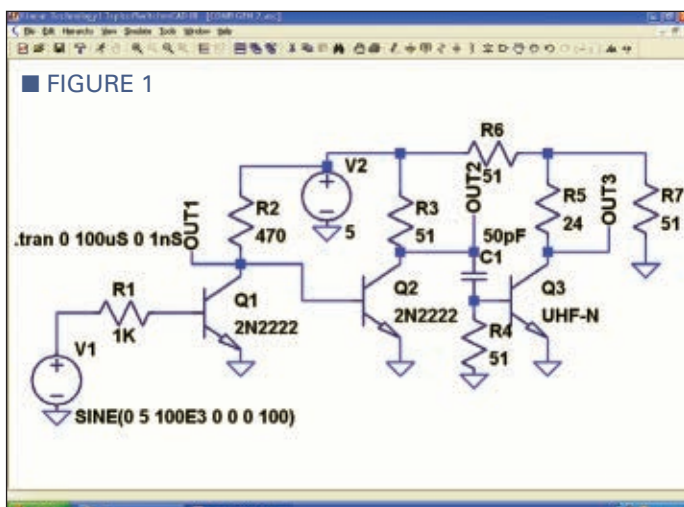

me with a simple circuit I want to fabricate. Here is my situation: I have solar panels on the roof of my fan camper to keep the batteries charged. A problem developed in the ignition switch that put four ohms to ground on the + side of the batteries. Since I wasn't using the van, I didn't notice the batteries going down. Eventually, what apparently happened was the batteries became so low they drew more current than the controller could handle.

The solar panels are putting out 19V but the controller was putting 0V into the batteries. The controller is a Solar Commander Series IV model FM16C made by Kyocera Solar, Inc., Kyoto, Japan which they no longer manufacture or repair. This controller is quite complicated with five LEDs, a screen that shows voltage, and a pushbutton to show amps. I don't believe I need such a sophisticated device. What say you? Am I a hopeless case or can you develop a controller that would suffice for my application? I wish to keep two 12V vehicle batteries charged. I can still read a schematic, more or less.

— Denis Kellogg

**A** I have been using a small (8 x 8 inches) solar collector to keep my truck batteries charged and it worked very well with no controller. I start the truck several times per year to circulate fluids and evaporate moisture. If you think the solar collector output current is sufficient to overcharge the batteries (one amp or more), you can connect the circuit of **Figure 4** across the battery to limit the voltage. If the transistor overheats, fasten it to a 4 x 4 inch piece of aluminum. I doubt that the circuit will be needed unless the solar collector is very large.

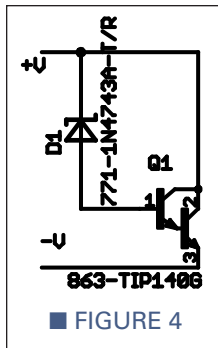

### DSL CARRIER DETECTOR

**Q** Myself and other technicians need a simple circuit that will show a DSL carrier. I have been to houses to check for lightning strikes and it would be nice to be able to check and replace filters or wiring that might be damaged rather than call in Old Ma Bell. Fluke makes some test sets but they are very expensive. Would you have any suggestions for a circuit? I'd like something with a possible LED to light for carrier present. I can use a

test-bud for dial tone. Your thoughts?  
— Mike Shelton, CET

**A** My reading indicates that there is not a particular carrier frequency, but there is a signal in the 100 kHz range. The circuit should reject voice frequencies and must survive the 70 volt ring signal. I don't know the signal amplitude but I doubt that it exceeds one volt. The circuit in **Figure 5** has a 10 LED bar graph to

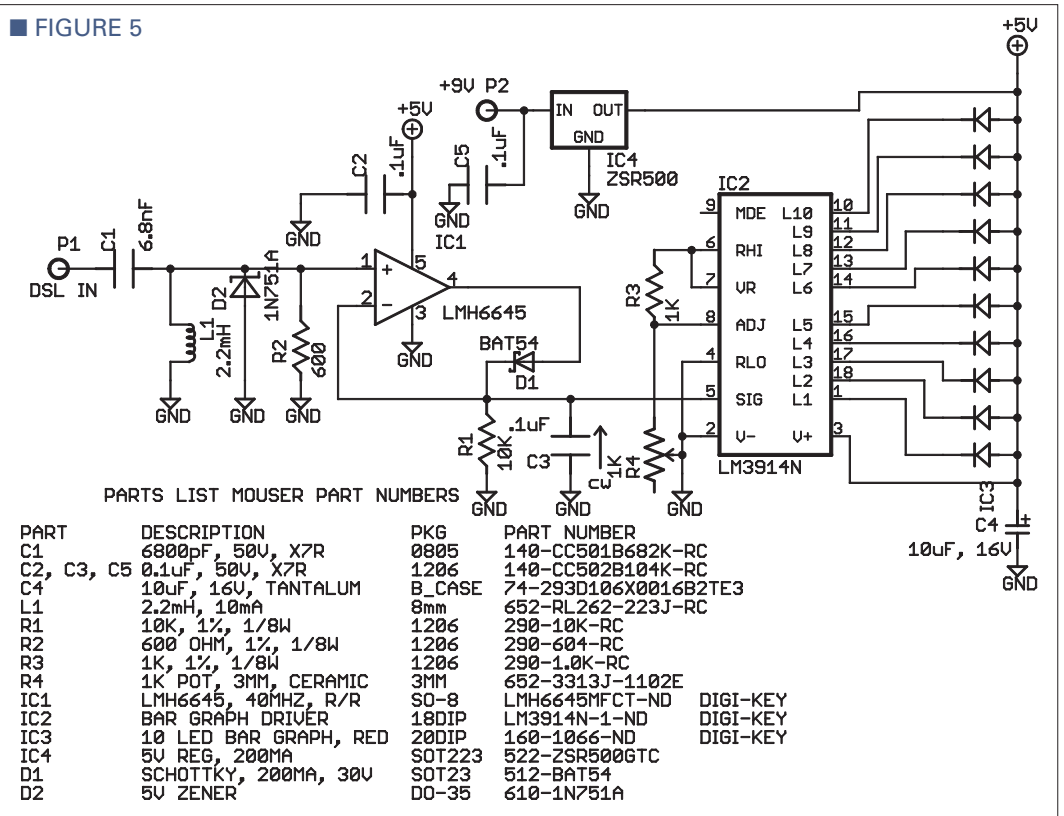
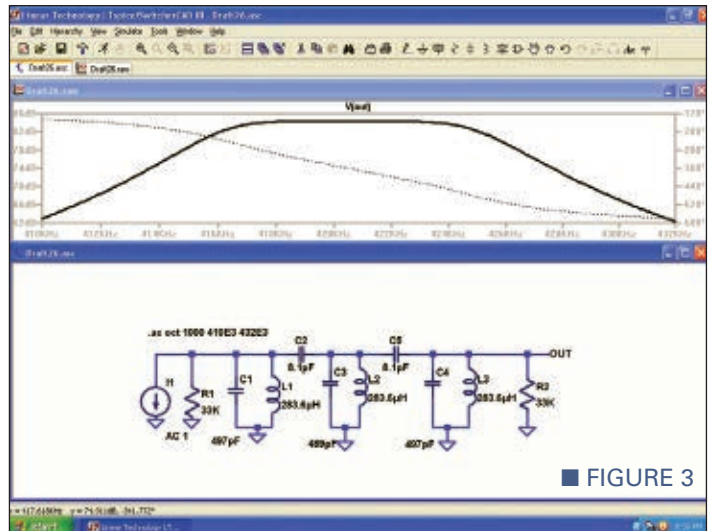

## MAILBAG

Dear Russell: Re: Power from Spring Runoff, June '11, page 22.

In your June Q&A, you gave an answer in "Power From Spring Runoff" on how to obtain electrical power from a mountain spring. For the 10 foot "head" you specified, it will take a flow of approximately 530 gallons per minute to get 1 KW, assuming an alternator of 90 percent efficiency. I don't think I have ever seen a spring produce this much flow. Power in a hydraulic generator system is a function of the pressure drop between the generator turbine inlet and discharge, and the volumetric flow rate through the turbine. In this case, the pressure drop is a 10 foot head of water (around 4.31 pounds per square inch) since the top of the spring and turbine discharge are both at atmospheric pressure. It takes a lot of water and/or a lot of pressure (head) to generate electricity. This is a fact not really understood by most of the alternative energy crowd.

— Tim Brown PhD, PE

*Response: Thanks for the feedback, Tim. I had no idea how much power could be developed.*

Dear Russell: Re: Wireless Control, June '11, page 25.

I've used X-10 modules for years; a Powerhouse RR501 RF transceiver converts the RF from any of their 'pocket' remotes to X-10 in conjunction with a contact module UM506. The module output can be wired across the open contacts of the garage door opener. It costs less than \$50, even if you don't have any X-10 stuff already! I was also able to have the receiver in my car learn the pocket remote.

— Dennis Jones

*Response: Thanks for the feedback, Dennis. This is*

another option.

Dear Russell: Re: USB Battery Charger, June '11, page 24.

The schematic and parts layout was inadvertently omitted from the recent issue of *Nuts & Volts*. Do you have a set that you can e-mail to me? Thanks

— M. Herman

*Response: Yes, my fault. I had two Figure 3s and only submitted one. The missing graphic is Figure A; it is a picture of the USB connector.*

Re: Video Amp, May 2011, page 26.

*Response: Toby Norton built the video amp and reports that it works great. He sent a photo of the finished circuit and power supply which is shown in Figure B. Figure C is the schematic of the plus and minus 5V power supply. Thanks for the feedback, Toby.*

Dear Russell: Re: Unknown IC, June '11, page 24.

While the SAD1024 is an obsolete (and very hard to find, if at all) chip, there are other BBDs (Bucket Brigade Devices) such as the MN3010 or the MN3007. The MN3010 is a dual 512 BBD — similar to the SAD1024 — while the MN3007 is a single 1024 BBD.

**MCMelectronics.com** has the MN3007 in stock while **DigiKey.com** lists both the MN3007 and the MN3010 for RFQ.

As for the TL057, is it possible that the designer meant to use a TL051 or TL052? Poorly written or bad copy can make a one or two look like a seven. Can't tell without the schematic.

— Charles Ryberg

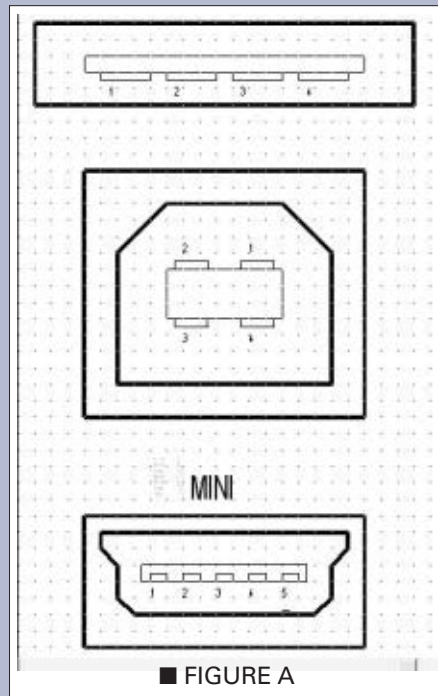

■ FIGURE A

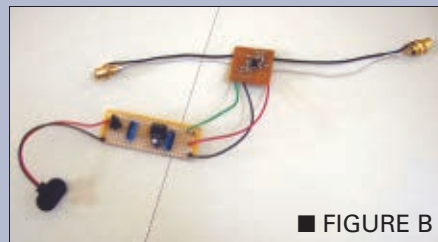

■ FIGURE B

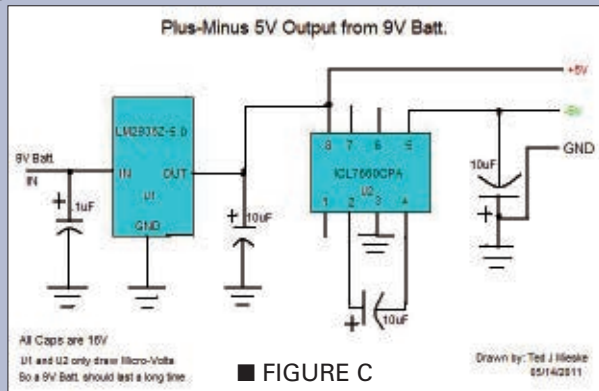

■ FIGURE C

indicate the signal level. When R5 is at ground (zero ohms), the maximum amplitude is 1.25 volts peak and when R5 is at maximum, the peak amplitude is 2.5 volts. The input circuit is a high-pass filter with a zener diode to protect the amplifier from spikes. I used 600 ohm impedance even though the line impedance may be less because the filter response is okay and the attenuation is less.

## 1.5V HOBBY MOTOR SPEED CONTROLLER

**Q** I am trying to control the speed of a 1.5 volt hobby motor. I have come up with the circuit of **Figure 6**. This speed controller works. However, I do not know how efficient it is or if my circuit is correct.

I used a basic circuit I found in

one of my Forrest M. Mims III *Engineer's Mini-Notebooks* and worked from there. I achieved my resistor and capacitor values, mostly by hit or miss or trial and error.

I do not know if any of the component values are okay or even close. I would like to know how to calculate these values, but I have no idea how to use these formulas and calculations. I would



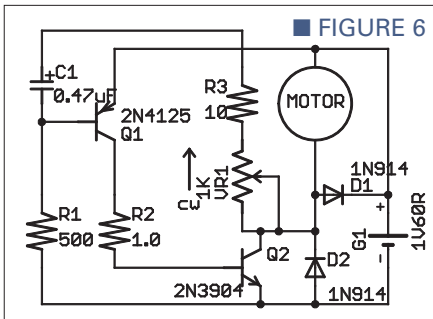

greatly appreciate the help and information.

I connected an ohmmeter to the + and - leads of the motor and it read 2.3 ohms.

— Mike Wandishin

**A** I tested the circuit (Figure 6) in Switcher Cad and it worked great, but I built the circuit and could not control the speed. I thought the small transistors were running out of current gain, so I used five amp power transistors: TIP42C for Q1 and MJE13007G for Q2. I think TIP41C would work for Q2, as well. The procedure I used was to remove C1 and adjust R1 for a collector voltage of Q2 in the 0.5 to 1.0 voltage range. This puts the circuit in the active range; if either transistor is saturated, the circuit will be stuck there.

First, I used 0.33 μF for C1 (I didn't have a 0.47 μF) and 100K for R1. The circuit worked okay and had a wide range of speed. I tried 2.2 μF for C1 and had to reduce R1 to 10K. It still worked but with smaller speed range. The motor I used was from Jameco (part number 231917) with a 1.5 to 3 volts DC rating. I did not use the diodes because the spiking was minimal.

The circuit is open loop, so when the motor is loaded it will slow down. Since a DC motor is also a generator, the generated voltage could be measured during the OFF time of Q2 and fed back to a controller. I experimented with this idea using a CMOS 555 timer but the IC — even though it works at 1.5 volts — has no drive capability. Something could be built at three volts but it gets complicated very quickly. **NV**



**BlueWolf  
ROBOTICS**  
[www.bluewolfinc.com](http://www.bluewolfinc.com)

**Boe-Bot Robot with FlashFly Combo Pack!**  
WAS \$259.00 NOW \$233.95!

RS-232 ADAPTER MODULE \$9.95

USB XBee EXPLORER BOARD \$19.95

MAXBOTIX - MAX SONAR EZ1 \$24.95

LED BOARD KITS \$1.49

RESISTORS: 1/4W 5% CARBON FILM SEVERAL TO CHOOSE FROM!

SWITCH TACT 6MM SQL=7.0MM 160GF \$5.95

BATTERY HOLDER W/9V SNAP \$2.99 & 9V BATTERY SNAP \$3.99

10 PIN 2.0MM XBEE FEMALE HDR SOCKETS \$3.95

SERVO EXTENDER CABLE- 6" \$1.65

USB MINI-B CABLE-3' \$3.95

**CALL US TODAY ABOUT OUR EDUCATION DISCOUNTS!**  
(208) 629-5222 [www.bluewolfinc.com](http://www.bluewolfinc.com) / [info@bluewolfinc.com](mailto:info@bluewolfinc.com)

FREE SCREWS! ENTER COUPON CODE: FREE SCREWS  
RECEIVE \$2.00 ON ALL FASTENERS ON US!



**EARN MORE MONEY**  
**Get your dream job!**

**Be an FCC Licensed  
Wireless Technician!**

**Make up to \$100,000 a year and  
more with NO college degree**

**Learn Wireless Communications and get your  
"FCC Commercial License" with our  
proven Home-Study Course!**

- No need to quit your job or go to school.
- This course is easy, fast and low cost.
- No previous experience needed!
- Learn at home in your spare time!



**Move to the front of the employment line in Radio-TV,  
Communications, Avionics, Radar, Maritime and more...  
even start your own business!**

**Call now for FREE info**  
**800-932-4268**

Or, online: [www.LicenseTraining.com](http://www.LicenseTraining.com)

**COMMAND PRODUCTIONS**

Warren Weagant's FCC License Training  
P.O. Box 3000, Dept. 209 • Sausalito, CA 94966

Please rush FREE info immediately!

NAME: \_\_\_\_\_  
ADDRESS: \_\_\_\_\_  
CITY/STATE/ZIP: \_\_\_\_\_  
email: [info@LicenseTraining.com](mailto:info@LicenseTraining.com)

# NEW P R O D U C T S

- HARDWARE
- SOFTWARE
- GADGETS
- TOOLS

## NEW HIGH SPEED USB TO MSP430 MICROCONTROLLER MODULE



**D**LP Design, Inc., announces their new DLP-2232MSP high-speed USB module based on FTDI's FT2232H and Texas Instruments MSP430F2618. The DLP-2232MSP combines the same USB interface used in the DLP-2232H and the DLP-1232H modules with a Texas Instruments microcontroller to form a rapid development tool.

The 16-bit RISC based MSP430F2618 microcontroller includes 12-bit ADC and DACs, numerous peripherals, and is preprogrammed with basic functionality for accessing the port pins, and can be reprogrammed with user firmware via a 10-pin header using a device programmer (purchased separately).

The module allows the user to send and receive data over a high speed USB 2.0 interface to and from a host computer. It has 32 digital I/O lines (eight can be configured as A/D inputs and two can be configured as D/A outputs) available for interfacing to user electronics via a compact 50-pin footprint.

No in-depth knowledge of USB is required as all USB protocol is handled automatically by the on-board FT2232H and its support circuitry. Royalty-free device drivers eliminate the need for USB driver development, and the required 5V supply can be taken directly from the

USB port or supplied by user electronics.

For more information, contact:  
**DLP Design, Inc.**  
Tel: 972-824-3930  
Web: [www.dlpdesign.com](http://www.dlpdesign.com)

## HYBRID A/D CONVERSION "SYSTEM ON A CHIP"

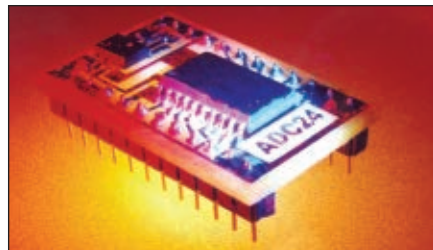

**E**lk Industries, LLC announces the release of its new ADC24 Analog-to-Digital System CMOS Hybrid Integrated Circuit. The unique features of this product make an easy to use analog-to-digital conversion system, all in a 24-pin DIP IC. Smaller in size and weight, this A/D conversion system requires only +5 volts, DC, and ground, as well as the analog signal input. It instantly produces eight-bit parallel digital data on its outputs. This "system on a chip" can handle analog signals from DC to 60-100 kHz in bandwidth. Only valid datum is presented on the (high true) digital data outputs. A convenient SYNC output indicates the latest update of the digital data on the outputs. The entire system fits into a standard 24-pin DIP IC socket and comes complete, ready to use.

Some of the features include single +5 volt operation, miniature size and weight, full eight-bit resolution, and its low power consumption (<100

milliwatts, typically). Each Hybrid IC is 100% performance tested. Applications include industrial controls, data acquisition systems, instrumentation, digital audio, communications, and automation, just to name a few. With the ever-increasing need to "digitize" data and signals in the real world, the implications of this advantageous system on a chip are several. The single IC approach makes A/D conversion easier because by using this device, essential real estate on circuit boards is reduced substantially, and is accomplished without increasing overall power consumption.

By using this IC solution, overall system costs can be reduced, as well. A detailed datasheet is provided to answer questions relating to hook-up and other design considerations.

The advanced analog-to-digital conversion system technology is part of a New Transformerless Battery Charging Technology developed by American Advanced Technologies, Inc. (AAT), and is tailored for use in the electric vehicle industry.

For more information, contact:  
**Elk Industries, LLC**  
221 W. Hibiscus Blvd. #106  
Melbourne, FL 32901  
Tel: 321-259-8114  
Fax: 321-723-2739  
Email: [laserob@aol.com](mailto:laserob@aol.com)  
Web: [www.elkindustries.com](http://www.elkindustries.com)

## TWO NEW INTEGRATED DIGITAL LOGIC TRAINERS

**G**lobal Specialties introduces its revolutionary family of integrated digital logic trainers. The

# SHOWCASE

**www.Primecell.com**

## Battery rebuilding service

Dead Batteries? Don't toss them. Send them to us - our rebuilds are better than original specifications.



**Tools**  
Hilti Skil Milwaukee Panasonic B&D DeWalt Makita All 2-36 Volts

**Electronics**  
Bar Code Scanners Surveying Printers Laptops Photography

**Radios**  
APELCO UNIDEN G.E. ICOM KENWOOD MOTOROLA MIDLAND MAXON YAESU ALINCO

Visit [www.primecell.com](http://www.primecell.com) for important details  
24 Hr Secure recorder tel-fax (814) 623 7000  
Quotes email: [info@primecell.com](mailto:info@primecell.com)  
Cumard Assoc. Inc. 9343 US RT 220 Bedford PA 15522

**QKITS.COM**

Power Supply: 12/24VDC Load Voltage

**30A PWM DC Motor Speed Control**

Control the speed of your electric motors or the brightness of your DC light bulbs.

**\$24.95**



Quantity discounts available  
**1-888-60-4-KITS**

Recycling & Remarketing High Technology

# WEIRDSTUFF®

WAREHOUSE

Software, Computers, Electronics, Equipment, Doohickies

WE BUY/SELL EXCESS & OBSOLETE INVENTORIES

FREE COMPUTER AND ELECTRONIC RECYCLING

GIANT 10,000 SQ. FT. AS-IS SECTION

**384 W. Caribbean Dr. Sunnyvale, CA 94089**  
Mon-Sat: 9:30-6:00 Sun: 11:00-5:00  
(408)743-5650 Store x324  
**WWW.WEIRDSTUFF.COM**

**BlinkM**

**Arduino**

I2C RGB "Smart LED" USB - BT - XBEE

Prototyping Supplies

**Serial LCD**

Save 5% with coupon code NV

# FunGizmos.com

**NKC ELECTRONICS**

**Zeroplus LAP-C 16032 Logic Analyzer**

16-channel - 100MHz - USB 2.0  
SPI - I2C - UART - 7-segment  
2 free additional protocols

**\$120**

**Arduino UNO \$29.95**

**Open Source Hardware**  
Arduino UNO - MEGA 2560  
Arduino Duemilanove \$24.95  
Freeduino - Seeduino  
DSO Nano  
Arduino Shields - Ethernet  
RGB LCD - XBee

**Rigol DS1052E DSO**  
50MHz - up to 1GSa/s  
1 Meg mem - TFT LCD - USB  
Advanced triggering: Edge, Pulse, Video, Slope, Alt

**Special \$399**

<http://www.NKCElectronics.com>

## Wireless Robotics Controller

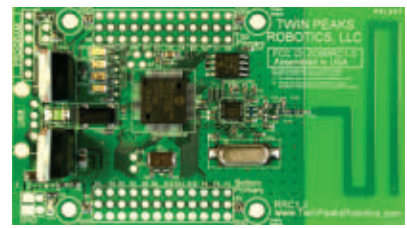

915 MHz Radio (FCC Part 15.249)  
16 MIPS Microchip PIC24 CPU  
24 Configurable I/O Ports with Power  
USB Master, 1 Mbit EEPROM, Real Time Clock

[www.TwinPeaksRobotics.com](http://www.TwinPeaksRobotics.com)

## CHIPINO

The Arduino Style Module for the Microchip PIC User

**\$19.95** kit  
**\$29.95** assembled



**WWW.CHIPAXE.COM**

## RF Specialists

### ZigBee Solutions ProBee Series

High Performance and Robust Data Transfer Capability  
ZigBee Solutions



**Low Cost  
Low Power  
Long Range**

**LEMOS INTERNATIONAL**  
[www.lemosint.com](http://www.lemosint.com)  
866.345.2667  
[sales@lemosint.com](mailto:sales@lemosint.com)

**ROBOT POWER™** *Extreme Motor Speed Control!*

MegaMoto - Motor Control for Arduino™

- 6V-28V - 13A / 30A peak
- Single H-bridge or dual half
- Current and Temp protected
- Jumper select Enable and PWM pins
- Up to three units stack on one Uno/Duemilanove



Dalf - \$250

- Closed-loop control of two axes
- Windows GUI for all features
- Full PID position/velocity loop
- Trapezoidal path generator
- Giant Servo Mode!
- [www.embeddedelectronics.net](http://www.embeddedelectronics.net)

>> Also H-bridges, gearmotors, plans, schematics <<

**www.robotpower.com**  
Phone: 253-843-2504 • [sales@robotpower.com](mailto:sales@robotpower.com)

## Nuts & Volts 7 CD-ROMs & Hat Special!

Complete with supporting code and media files.



**Only \$149.95**

**www.nutsvolts.com**

**Free Shipping!**

Published monthly by T & L Publications, Inc. [www.nutsvolts.com](http://www.nutsvolts.com)

# BUILD A CIRCUIT BOARD ASSEMBLY JIG

I spend a considerable amount of time assembling and soldering circuit boards for my profession, as well as a hobby. One of my biggest frustrations has always been securing the PCB in such a way that it cannot move or vibrate, but still allows plenty of access for the soldering iron. Over the years, I have purchased — and been disappointed with — various types of circuit board vises and fixtures. The ubiquitous “third hand” gripper was too flimsy. Others had jaws specifically for circuit boards, but I found them to be too deep or improperly sized. Most could not hold more than one PCB at a time. And there was one feature in particular that I was looking for: a reliable way to hold through-hole components in place, upside down, while I soldered on the other side of the board. This article describes my solution.

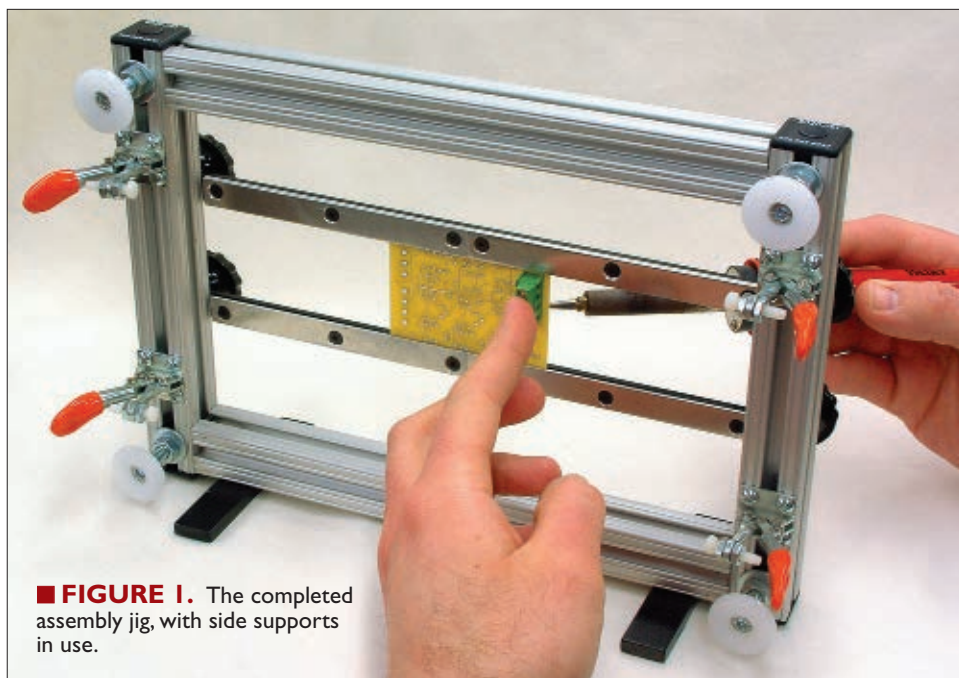

■ **FIGURE 1.** The completed assembly jig, with side supports in use.

## THE DESIGN

I loosely based my design on photos I had seen of professional circuit board reworking equipment (costing in the hundreds or even thousands of dollars). These systems use a piece of soft foam rubber to hold components in place, allowing soldering work to be done on the opposite side. I decided to use T-slotted extruded aluminum for the jig frame, from 80/20, Inc. ([www.8020.net](http://www.8020.net)). The T-slot system is very versatile, as T-nuts can be used to mount

components at any location on any of the four sides.

Two notched rails were fabricated which capture the circuit board(s) and can be adjusted as necessary in the T-slots. The foam is attached to a backer plate which is inserted through the opposite side of the jig and applies slight pressure to the circuit board. Knowing that this foam would be installed and removed frequently, I chose to use quick-release toggle clamps to hold it in place.

After trying out the jig with several different PCBs, I found that certain large or odd-sized components had to be manually held in place while being soldered. This proved difficult since the parts are normally underneath the jig during soldering. My solution was

to install two strips to the front of the jig using T-nuts which are normally parallel to the extrusion, but can be rotated 90 degrees to provide an extra set of feet. The jig can then be set on its side, allowing access to both sides of the circuit board. **Figure 1** shows the jig in this setup.

## FABRICATION and ASSEMBLY

Most of the components were purchased from McMaster-Carr ([www.mcmaster.com](http://www.mcmaster.com)); refer to **Table 1**

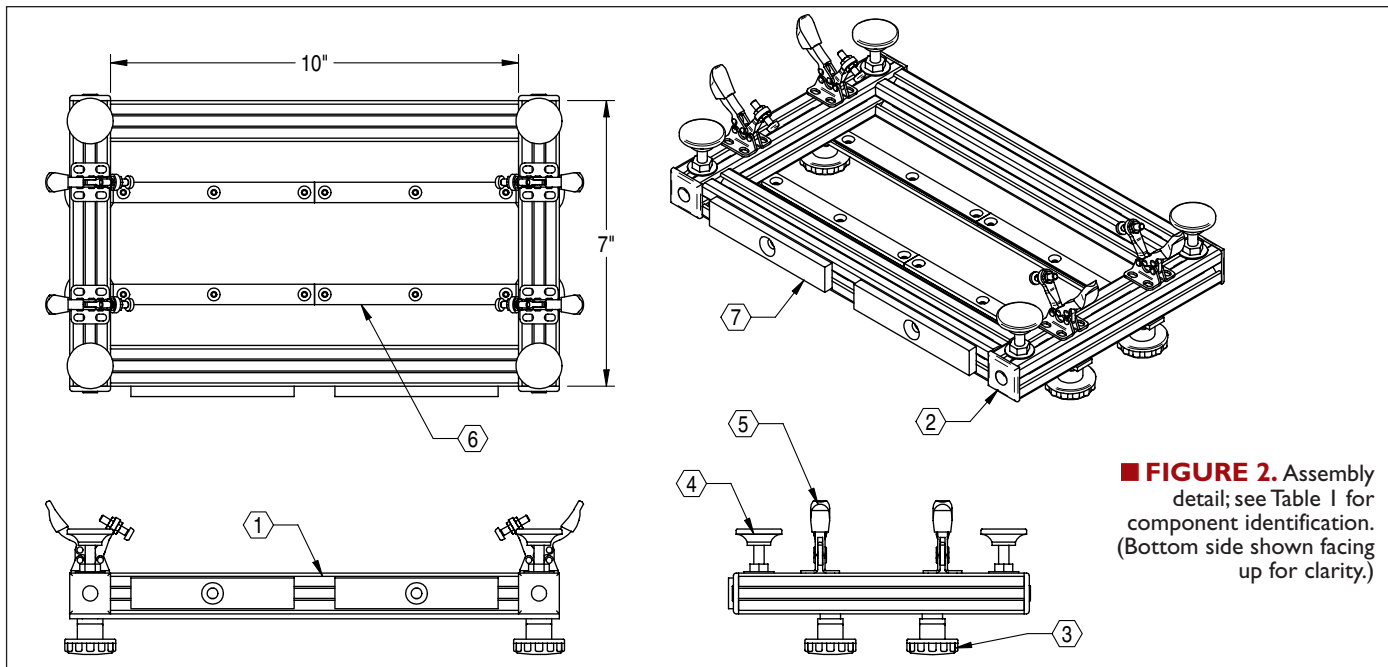

**FIGURE 2.** Assembly detail; see Table 1 for component identification. (Bottom side shown facing up for clarity.)

and the assembly drawings in **Figure 2**. Locally available common parts – such as fasteners and aluminum bar stock – are not included in the list. The only special tools required for construction are thread-cutting taps of several different sizes, and the corresponding tap drills. The part numbers shown in **Table 2** are for spiral point taps, a.k.a., “gun taps,” which can be used in a reversing power drill or drill press. First, cut the extrusions to length as indicated. A hacksaw cut would be sufficient, but most power miter saws can cut aluminum and provide a much cleaner result. In order to assemble the frame using the extrusion connectors, the ends of the 10” pieces need to be threaded 1/4”-20. The hole through the center of the extrusion is already the proper diameter to be tapped this size. **Figure 3** shows the usage of the extrusion connector; 1/4” diameter holes should be drilled 1/2” from the ends of the non-tapped extrusions to provide access for a 5/32” hex wrench to tighten the connector. Note that the T-nuts must be inserted before the frame is assembled: four on the top side for the knobs; four on the bottom side for the feet; and two on the front side for the rotating side supports. Plastic end caps are available which cover the exposed ends of the extrusion, mainly for cosmetic purposes.

The leveling feet and toggle clamps can

be attached to the bottom side once the frame is assembled. Install a washer and nut onto each foot stud before threading it into the T-nut; this will allow the feet to be adjusted individually so that the jig sits flat on your work surface. The mounting holes in the toggle clamps don’t line up with the T-slot, so they will need to be screwed down. Position each clamp and mark the hole locations, then drill and tap partially through the extrusion for #8-32 thread.

Thread Size	Tap P/N	Drill P/N
#6-32	2523A446	2930A49
#8-32	2523A447	2930A42
1/4"-20	2523A411	2930A17

**Table 2.** McMaster part numbers for required taps and tap drills.

### TABLE 1. MASTER PARTS LIST

ITEM	DESCRIPTION	QTY	MFR P/N	DIST P/N
1	Aluminum T-slot extrusion	2	80/20 #1010	McMaster 47065T209 (Two ft length; cut to size)
	T-nut, 1/4"-20 thread	10	80/20 #3382	McMaster 47065T142 (Four per pkg)
2	Extrusion connector	4	80/20 #3381	McMaster 47065T155
	Extrusion end cap (optional)	4	80/20 #2015	McMaster 47065T91
3	Knob w/ threaded stud	4	N/A	McMaster 6479K88
4	Leveling mount	4	N/A	McMaster 23015T82 (12 per pkg)
5	Toggle clamp	4	Fargoware FC-20 De-Sta-Co 205-S Carr-Lane CL-150-HTC	MSC Industrial 76988120 <a href="http://www.mscdirect.com">www.mscdirect.com</a> (Also available on eBay)
6	Board support rail (see Figure 4)	2		
7	Side support (see Figure 5)	2		
	Foam compression plate (see Figure 6)	1		

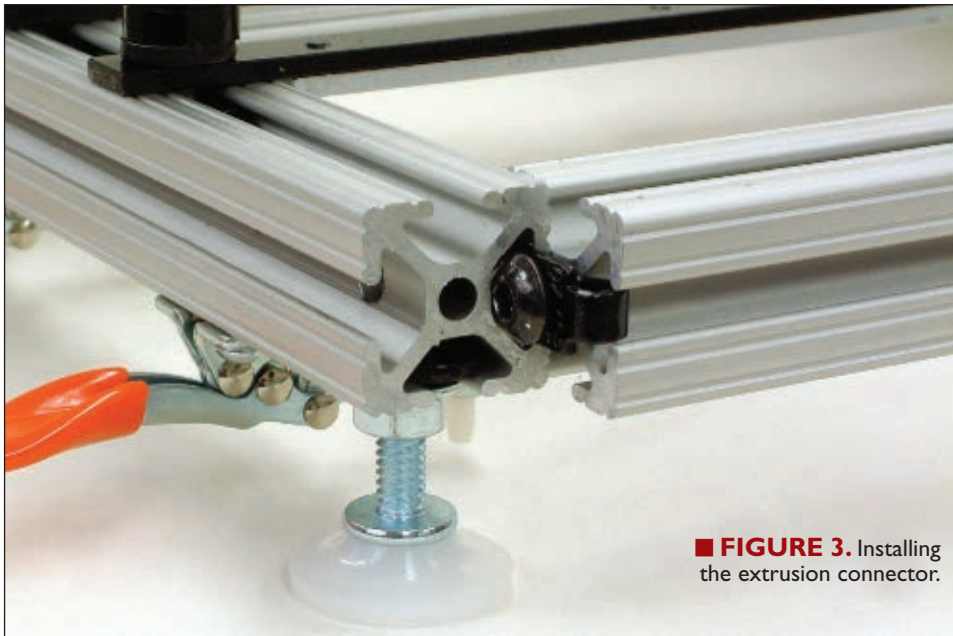

■ **FIGURE 3.** Installing the extrusion connector.

The design of the board support rail can vary depending on the type of equipment you have available to fabricate it. The key feature, of course, is the small cutout where the PCB will fit. The width of this notch depends on the thickness of the circuit boards you will be using, but 1/16" (0.063") is the most common size.

An important design point for me was making the depth of the notch as shallow as possible, since I often work with boards that have components mounted almost to the very edge. I have access to a milling machine, so I chose to fabricate each support rail from two sections of 1/8" x 1/2" aluminum sandwiched together (see **Figure 4**).

The notched component ended up being two identical pieces butted end-to-end, as this made the machining easier. To attach the sections, clamp them together and drill a number of pilot holes (I used six; four would be sufficient). Separate the sections, then countersink the holes in the notched piece(s) and thread the other holes for #6-32 thread.

**Figure 4** also shows an end view of an alternative method for constructing the support rail, with no milling required. Replace the notched section with two pieces of 1/16" x 1/2" aluminum. Clamp everything together with the center section offset to create a cavity for the PCB edge, then drill and tap as described previously. It may be necessary to add a thin shim between two of the sections in order for a 1/16" thick board to slide easily.

Once the support rails are complete, they can be attached to T-nuts on the top of the jig using the threaded knobs. If you use the knobs specified in **Table 1**, add a few washers to each stud before assembly. (Otherwise, the knob will

contact the bottom of the T-slot before it tightens against the support rail.) Alternatively, you could cut approximately 1/8" off the end of each stud.

Refer to **Figure 5** for dimensions of the side supports. I used aluminum, but any sturdy material will do. The exact dimensions aren't critical, but the piece must be thick enough to fully countersink a 1/4" flat head screw. I applied a few self-adhesive rubber furniture feet to each support to keep the jig from sliding around. The foam backer plate can be made from any thin sturdy material (I used 1/8" aluminum sheet; see **Figure 6**).

Depending on the material thickness, the threaded studs on the toggle clamps may need to be adjusted so that they clamp snugly but without excessive force. A piece of 1" thick foam rubber should be sized to fit loosely through the jig frame, approximately 5" x 9.75". I used inexpensive polyurethane foam – available in sheets from a local craft store – and bonded it to the plate with 3M Super 77 spray adhesive.

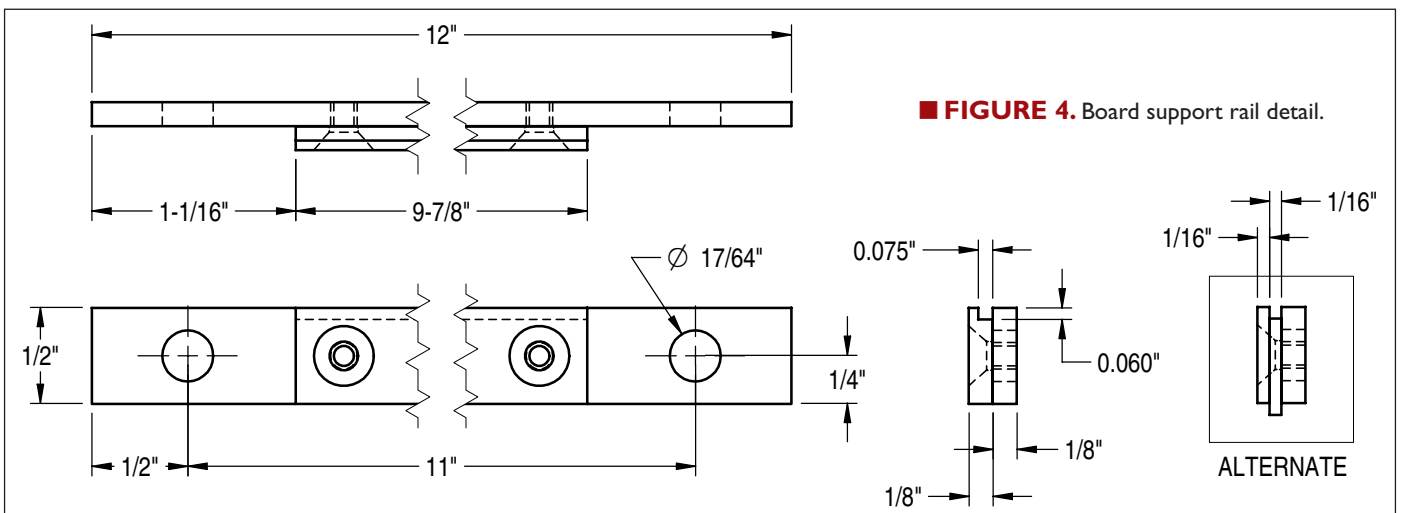

■ **FIGURE 4.** Board support rail detail.

## USAGE TIPS

The first step in board assembly is to populate the PCB. Generally, components should be installed from smallest (shortest) to largest (tallest). For through-hole

components, I find that the foam compression works best for low-profile parts such as resistors, diodes, and DIP ICs. In this case, position the jig with knobs down and install the PCB with the component side facing up as in **Figure 7**. For maximum strength, the long side of the board should be oriented parallel to the support rails. After placing the components, clamp the foam plate in place and turn the jig over for soldering (see **Figure 8**).

I was initially concerned that heat from the soldering iron would melt the polyurethane foam, but so far this has not been a problem. For larger components, I tend to either use a non-conductive superglue or bend the leads slightly to keep the parts in place while upside down. Glue is also helpful with SMT components, even though placement and soldering is done from the same side.

Some components just don't work well with any of the aforementioned holding techniques. This was recently the case with a certain terminal block that I was using. It was too large to be clamped with foam, had leads that were too short to bend, and didn't respond well to superglue. As shown back in **Figure 1**, the rotating side supports help with these situations. A small amount of solder is first applied to one of the component's holes in the board. Then, with the component in one hand and the soldering iron in the other, the solder plug is melted as the part is inserted. The other pins can then be soldered as normal.

## WHERE TO GO FROM HERE

I spent about \$80 on the parts for this jig. To me, it was a very worthwhile expense considering the number of

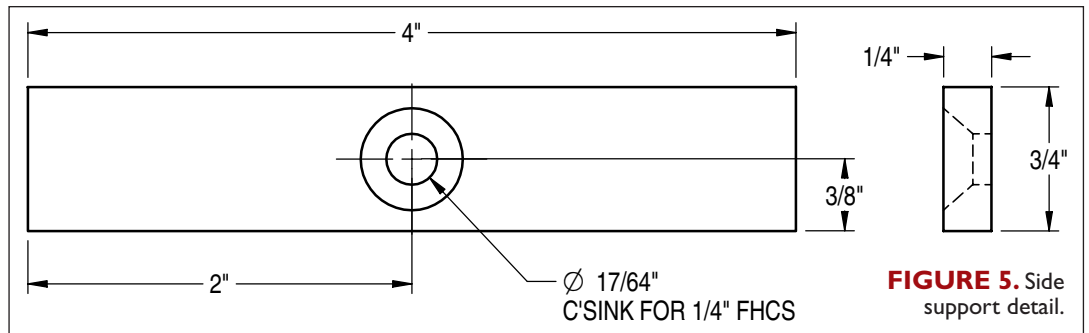

**FIGURE 5.** Side support detail.

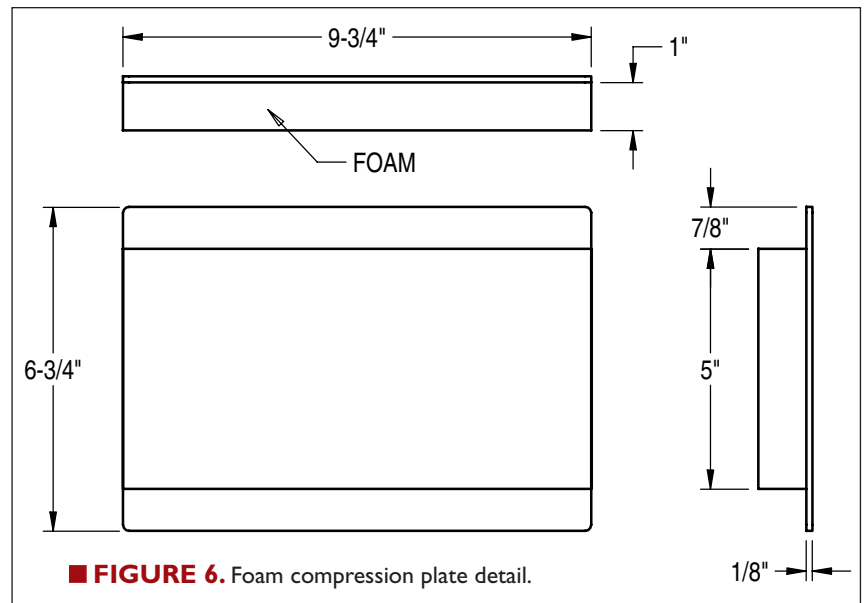

**FIGURE 6.** Foam compression plate detail.

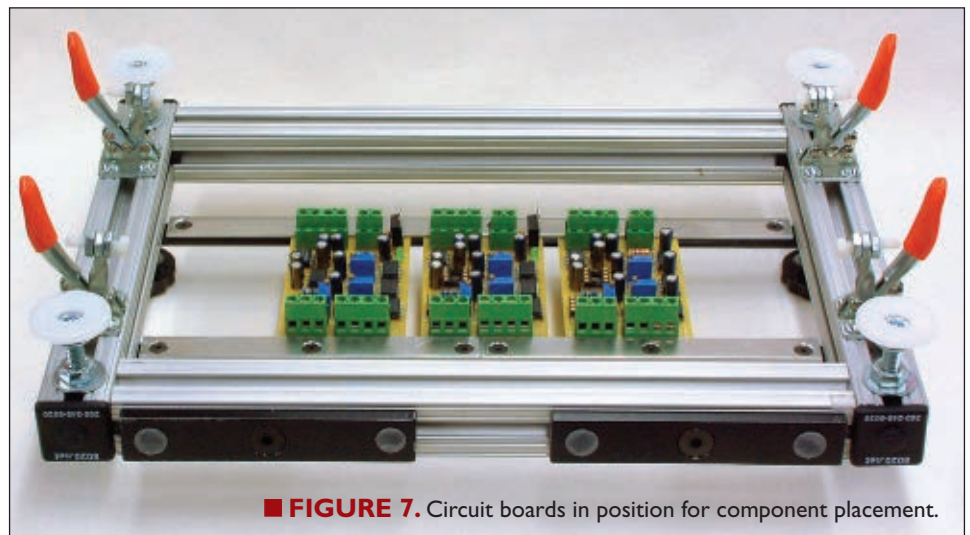

**FIGURE 7.** Circuit boards in position for component placement.

boards I assemble and the quicker workflow that it provides. A hobbyist might find the cost excessive, but it could be built for significantly less depending on your needs.

Probably the most obvious solution would be to reduce the size of the jig. I don't work on boards that are particularly large, but I wanted the ability to assemble multiple boards at a time — something that many users



■ **FIGURE 8.** Jig oriented for soldering. Note leaded components held in place by foam.

## THROUGH-HOLE VS. SURFACE-MOUNT

Surface-mount technology (SMT) has slowly replaced traditional through-hole designs for many components. It offers the advantage of a reduced footprint resulting in higher circuit density, and is more conducive to automated assembly and soldering. Through-hole technology remains in use mainly for higher powered components and those which require mechanical stability through the solder joint. It also lends itself well to hand soldering and prototyping. The jig described in this article can be used in several different orientations and streamlines PCB assembly with either type of component.

work mainly with surface-mount parts or have other ways to hold through-hole components in place.

The versatility of the T-slot system offers many possibilities. Perhaps a miniature gooseneck lamp or magnifier mounted to the soldering side of the jig? One nice feature I noticed on the expensive professional units was a pivoting system – the entire jig could be set on an angle to face the user during soldering or assembly.

Even without all the bells and whistles, I can assure you that having a proper PCB assembly jig goes a long way toward making electronics a more enjoyable hobby.

**NV**

# CU-Y Highlight Menu

<http://itron.tv/CYH1>  
(847) 439-9020

Exclusively available with Noritake CU-Y

Code library now available!

### CU24063-Y1A

CU-Y highlighted menu capability.

- Brightness control allows selectable menu.
- Easy visibility with font sizes.
- International font tables access foreign languages.

### Advantages of VFD technology

- Emissive bright display.
- Fine pitch and easy to read.
- Wide viewing angle.
- Wide operating temperature.
- Quick response.
- Evaluation kit available.

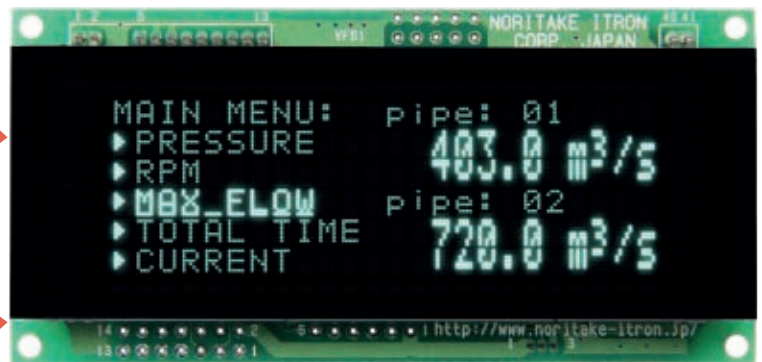

**Actual size**

PCB size: 98 x 47 mm



Visit online for more VFD modules:



**Star Bright**

**Noritake itron**  
The brighter side of electronics

Noritake Co., Inc.

2635 Clearbrook Drive Arlington Heights, IL 60005





This is just a sampling of the thousands of products we offer! Visit [www.saelig.com](http://www.saelig.com) for more great unique electronics!



**7-in-1 Scope**  
2-ch 10-bit 2MHz scope & spectrum analyzer & wfm gen. **CGR-101 \$199**



**50MHz Scope**  
50MHz 2-ch 2GS/s scope w/ 2000 wfm/s refresh rate. **DS1052E \$399**



**Mixed Sig. Scope**  
100MHz scope, spectrum and logic analyzer. 4MSa storage. **CS328A \$1359**



**USBscope50**  
Thumb-drive-size PC based 50MSa/s scope - connects via USB port. **\$199.95**



**Custom Meter**  
High contrast 2.4" TFT color LCD w/ built-in touch screen. **SGD 24-M \$90.25**



**SPI Storm**  
Dual- & Quad- Serial Protocol Host Adapter controlled from PC through USB. **\$1199**



**.NET Boards**  
Tiny open source boards w/ Microsoft's .NET **FEZ Mini & FEZ Domino \$39+**



**Windows Touchpanel**  
Touch-input 10.2" LCD 12V powered Windows PC 4GB **CUPC-P80/90/100 \$849+**



**25MHz Scope**  
2-ch 25MHz color LCD - FFT, autoscale, & trigger delay functions. **PDS5022S \$287**



**Camera Board**  
Compact compressed-serial output module for any host system. **uCAM \$58**



**I/O Controllers**  
Simple-to-use universal I/O controllers for USB interface. No drivers req'd. **\$10.35+**



**OLED Displays**  
Compact smart OLEDs w/ graphics for stand-alone functionality. **\$36.90+**

888-772-3544 [www.saelig.com](http://www.saelig.com) [info@saelig.com](mailto:info@saelig.com)



Back-to-school discounts on basic kits at [paia.com](http://paia.com)

Electronic Kits for Enthusiasts

**BUILD YOUR OWN!**

**PAiA 9700s**  
Modular Synthesizer



**FatMan**  
Analog MIDI Synth



**Theremax**  
The Ultimate Theremin



Check out these and other exciting D.I.Y. projects!

**PAiA** [paia.com](http://paia.com) Music/Tutorials/Kits  
Guitar Effects  
Tube Electronics  
Studio Gear



**AP CIRCUITS**  
PCB Fabrication Since 1984

As low as...

**\$9.95**  
each!

Two Boards  
Two Layers  
Two Masks  
One Legend

Unmasked boards ship next day!

[www.apcircuits.com](http://www.apcircuits.com)



# WEB BROWSER CONTROL OF YOUR HOME

Part I

# THERMOSTAT

By Jürgen G. Schmidt

Learn how to control the thermostat (or thermostats) in your house without getting out of your chair or bed.

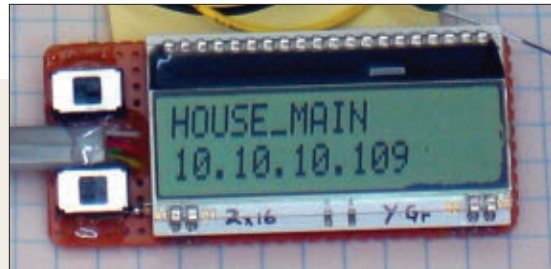

This project shows how to build a hardware interface to connect your thermostat to the Internet, and then control it from your computer or cell phone browser.

I had just settled down for the evening. The cat was in my lap, my favorite beverage was at hand, and I'm reading the latest issue of *Nuts & Volts*. All of a sudden, I hear the upstairs air conditioner turn on. I forgot to turn it off before coming downstairs again. I now have a couple choices. I can: A) Listen to it waste electricity while I try to relax or, B) get up and disturb the cat, who will probably not return when I do. Eventually I do B, and start thinking about avoiding this in the future.

Just as frequently, I'm sitting at my desk in a room that is not close to the thermostat. The temperature in my office does not correlate well with the temperature in the hallway where the thermostat is, and I have to make frequent adjustments to stay comfortable. Doing that from a browser window on my computer would be much more convenient than getting up from my desk and walking down the hall.

The true mother of invention is laziness and this child was just begging to be born. In approaching this project, the first question to answer is what device do I want to use as my remote? What device is always near me, even when I go to sleep? Is it the TV remote, or the X-10 or Z-Wave home automation controller? It's the cell phone! My latest model — an HTC EVO — has a web browser and Wi-Fi access. My house has a Wi-Fi access point for my laptops. So, clearly, I need a browser interface for my thermostats.

When I built my house a little over 10 years ago, I put in a lot of CAT-5 network cable for computers and telephones, including running a cable to each of the

thermostats — assuming it would come in handy some day. Well, that day finally arrived. These cables terminate in a wiring closet containing — among other things — the network router and Wi-Fi access point. The CAT-5 cables will provide both power and a network connection to the thermostats.

As I thought more about this, I settled on some basic requirements:

1. Anyone familiar with a basic home thermostat should be able to understand and operate the new one.
2. The browser interface must coordinate with the wall-mounted units.
3. The thermostats have to continue working even if the network fails.
4. The overall size and shape of the wall-mounted portion should not be much different from the current one.

I've been working with Microchip microcontrollers for a while, and have used the Microchip TCP/IP network software stack along with stand-alone Ethernet modules to interface my microcontroller projects to networks. Relying on this background, I mocked up a proof of concept using a breadboard. This consisted of a Microchip ENC28J60-based Ethernet module connected to a Microchip PIC24HJ128GP202 28-pin dual inline package (DIP) microcontroller. The results can be seen in **Figure 1**.

I made DIP prototype modules for the temperature

sensor, memory, and MAC address chips since these only come in surface-mount formats (see **Figure 2**). For the mockup, I used LEDs to represent the relays that will turn on the fan, heater, and cooling components. I wrote an initial version of the thermostat program, combined it with the Microchip TCP/IP stack, and loaded it into the chip. I verified that I can control a thermostat from a web page and a wall-mounted interface. The LCD displays current temperature and humidity, along with the set point and status of the heater, fan, and air conditioner.

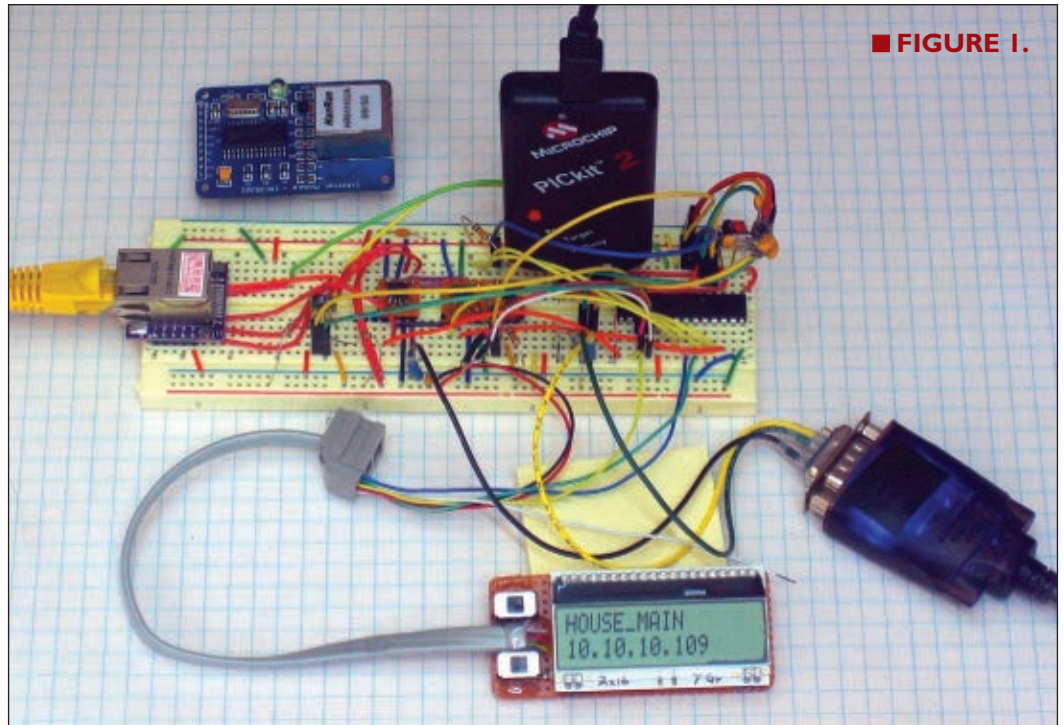

■ **FIGURE 1.**

## Design

While it would work, mounting the breadboard on the wall is clearly not an option. Some additional design goals are related to producing something nice that will not offend the aesthetics of family members and will also be easy to make. For ease of construction, the connectors, switches, and display should be mounted on the circuit boards. I have two heating and cooling systems in the house, so I will be making two of them with at least one or two extra to experiment with. In order to control the thermostat from a web browser or client, each thermostat will include an embedded http or web server. With this in mind, I laid out all the major components for the project. The web server section will need:

- PIC microcontroller
- Web page memory
- MAC address chip
- Ethernet module with RJ45 connector
- RS-232 interface
- RS-232 connector
- Power plug
- Programming connector

The thermostat user interface will need:

- LCD display
- Switches
- Temperature and humidity sensor
- Relay driver

- Relays
- Connector for HVAC control

The initial design focused on a single circuit board. However, while I was working on it, I started thinking of some of the other cool projects for an embedded web server. This — along with the impending large size of a single board implementation — led to a double-decker design. The TCP/IP base board will contain all the

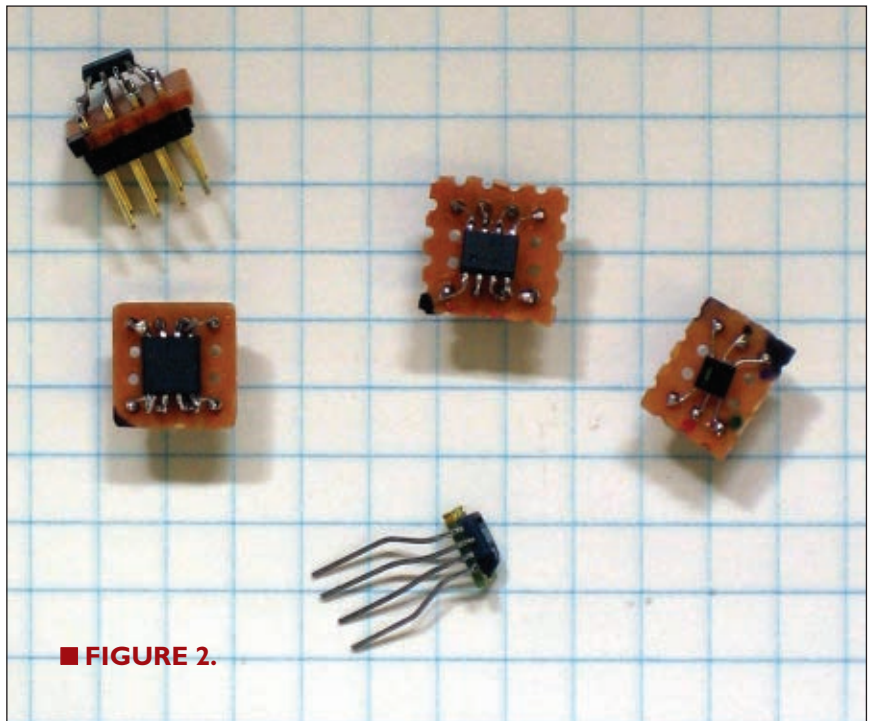

■ **FIGURE 2.**

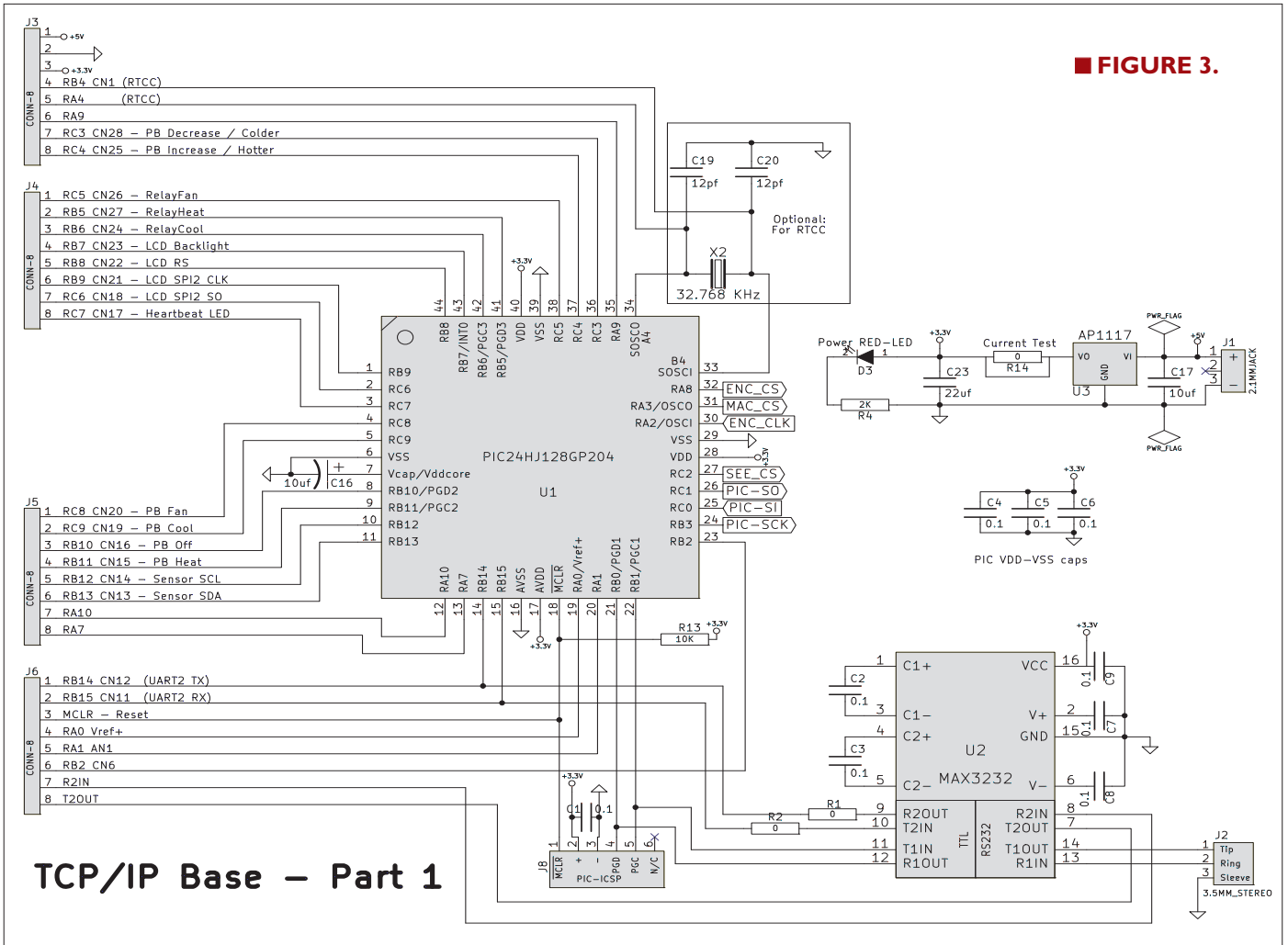

■ FIGURE 3.

## TCP/IP Base – Part 1

hardware for supporting the embedded web server. A thermostat daughter-board will contain all the components unique to the physical thermostat functions. This lined up neatly with the two lists of major components. Not only will I end up with a compact design, I will also have a TCP/IP development system I can use in other projects.

## TCP/IP Base

To date, I've used either off-the-shelf web server boards or connected pre-made ENC28J60 modules to my processors of choice. Two of these modules are also shown in **Figure 1**. One is at the left end of the

## Testing and Revision – Using a Bootloader

All products go through a period of testing and revision before final user acceptance. After several cycles of mounting and dismantling the hardware to reprogram it after testing and getting feedback, I decided to invest in a bootloader that would work over the Ethernet connection. This would allow me to update the software without dismantling the thermostats. The only Ethernet bootloader for the PIC24 I could find is the Encrypted Ethernet Bootloader from Brush Electronics in Australia. The author, Andrew Small, was quite patient and responsive to my queries. He is active on both the Microchip and CCS software forums, and I've learned a lot from his posts over the years. The \$100 cost is worth the time it saves on this and other projects.

After some delays tracking down nearly invisible typos in my configuration files, the bootloader took only a few hours to set up for my hardware, including making some minor changes to the linker scripts. It does not require any changes to the application software. This was my first experience with a bootloader, and if you've never used one before, it's really cool! I can update an application anywhere in the universe, as long as it's connected to the Internet. It's not convenient for benchtop testing because it adds a few steps to the typical compile/load/go sequence. However, the same application hex file the bootloader uses will run stand-alone on the hardware without the bootloader installed, so you only need to compile a single version of the application for testing both with and without the bootloader. See the **References** for more information about bootloaders.

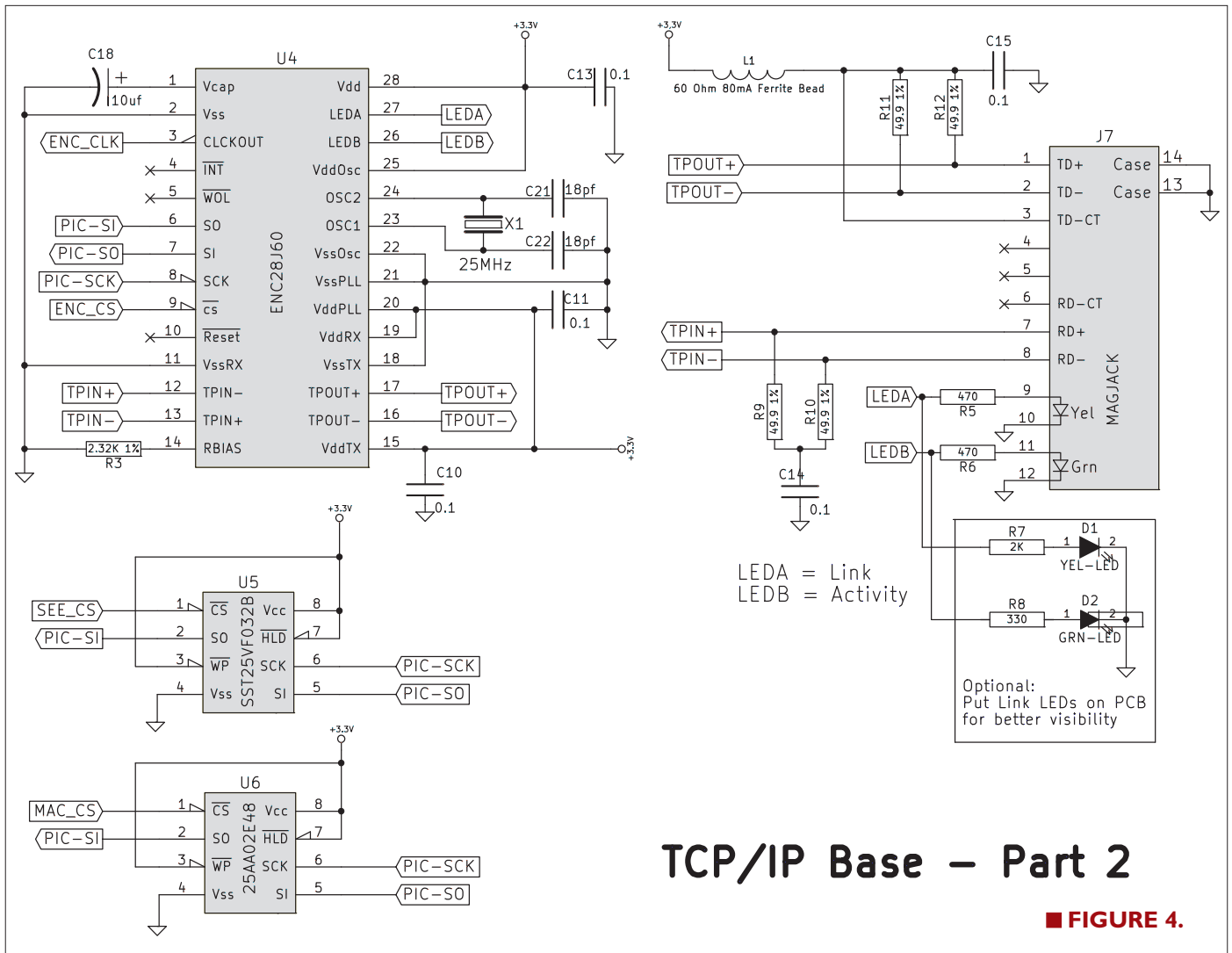

breadboard and a different version is lying above it.

For this project, I decided it was time to design my own network interface, along with the necessary components to have a complete TCP/IP development system. The ENC28J60 datasheet provides all the basic information, and schematics for the Microchip development boards that support an Ethernet interface provide examples of real life implementations that I used as the starting point for my design.

Working with the breadboard mockup to refine the design, I found that I was running out of I/O pins with the 28-pin part. To support all the thermostat functions and to ensure a truly general-purpose TCP/IP development platform, I would have to use a 44-pin device. The PIC24HJ128GP204 44-pin processor has a 16-bit core that runs at 40 MIPS and has 128K of Flash memory for program storage. It costs about \$5 if you buy 10 or more.

The TCP/IP software that supports the embedded web server along with the thermostat application will eventually use a little more than half of the Flash memory, so there is plenty of room for growth; for example, adding

a bootloader. (See the **sidebar** on Testing and Revision – Using a Bootloader.) The processor supports two SPI buses. One of these is used to connect to a SST25VF032B serial Flash memory chip that will store up to 4 MB of web page content, a 25AA02E48 MAC address chip that provides a universally unique hardware address for the board, and the ENC28J60 Ethernet interface chip. These three support chips share the three SPI bus pins and use one additional pin each for the chip select line. The second SPI bus is used to connect the LCD display. The UART1 peripheral on the processor is connected to a MAX3232 chip to provide a serial interface. This provides the debug output along with the heartbeat LED, and I use a compact 3.5 mm stereo connector for the physical serial connection. The ENC28J60 interface is connected to a Magjack which is a RJ45 connector with built-in LEDs and isolation transformers.

Power comes from a regulated five volt source. This is reduced to 3.3 volts for all the TCP/IP base components via the AP1117 regulator. I decided on five volts because I will need that to power the relays. Also, since this is going

■ **FIGURE 5.**

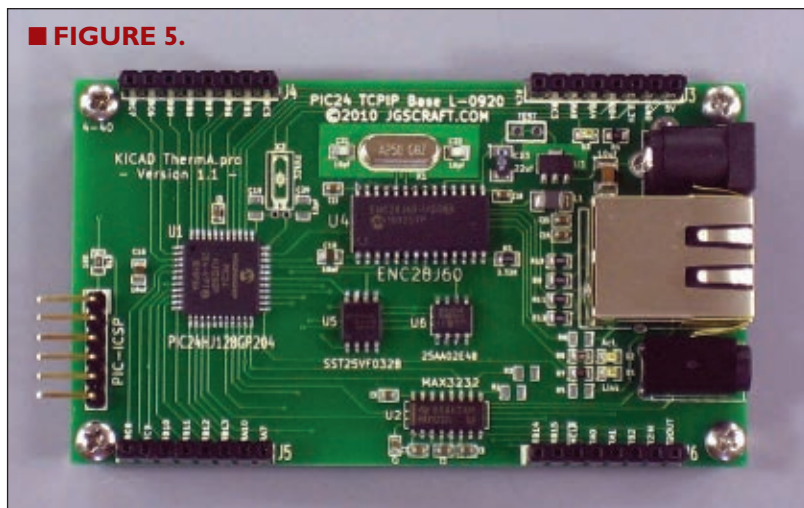

to be my development board, I wanted both 3.3 and five volts available. The entire thermostat implementation – with relays tripped – draws about 220 milliamps. Most schematics for PIC-based TCP/IP designs use two crystals: one for the ENC28J60 and one for the microcontroller. Based on information I found on the Microchip forums, I decided to use a single crystal for the ENC28J60 and then use its CLOCKOUT signal to provide the clock for the microcontroller. This reduces the parts count and frees up an extra I/O pin.

Circuit diagrams for the TCP/IP base are shown in **Figures 3** and **4**. The completed 2" x 3.5" board is shown in **Figure 5**. In anticipation of future projects with this board, I added some optional circuitry. A 32 kHz clock crystal can be added to provide a real time clock. By default, only half of the MAX3232 is used. By adding some 0 ohm resistors, the second half can be connected to the UART2 peripheral of the microcontroller.

When I was testing the circuit on the breadboard, I

had a hard time seeing the Ethernet activity LEDs on the Magjack, so I added some LEDs on the PCB (printed circuit board) to make it easier to see them. You can select which ones to use by populating the appropriate resistors. All the unused I/O pins – along with ground, 3.3 and five volts – and the UART2 lines from the MAX3232 are routed to four eight-pin female headers. The circuit diagram (**Figure 4**) labels the connections that are used by the thermostat daughterboard.

Some of the devices in the PIC24 family of microcontrollers have features that support design flexibility. The In-Circuit Serial Programming (ICSP) connector can be attached to one of several sets of pins. The Peripheral Pin Select (PPS) feature allows you to assign digital

interfaces such as the SPI and UART to any of the pins that support PPS. Programmable weak pull-ups on some of the pins reduce the parts count and wiring complexity by eliminating pull-up resistors.

In the course of drawing the schematic and preparing the PCB layout, I went through several iterations of laying out the schematic, routing connections on the PCB layout, and then returning to the schematic because I found a more efficient layout based on the physical arrangement of the components. These changes are easily accommodated in the microcontroller software by reassigning functions to different pins.

## Thermostat

The basic home heating and air conditioning system (HVAC) is controlled via four wires connected to a mechanical or electronic thermostat. The four wires are labeled COMMON, FAN, HEAT, and COOL. The job of the thermostat is to close a circuit between the COMMON and HEAT or COLD, and, if desired, the FAN. The FAN connection turns on the fan full time instead of just when the heater or A/C is running. A simple approach for the computer-controlled thermostat is to use three relays to control the closing of the three circuits.

The mechanics and operation of a thermostat are pretty simple. If heating is enabled, turn on the heater if the measured temperature is lower than the set temperature. If cooling is enabled, turn on the air conditioner if the measured temperature is higher than the set temperature. To implement this, we need a temperature sensor, some switches, a display, and the aforementioned relays to control the HVAC unit. The temperature sensor and the relays – along with a means for activating them – are the only parts that have to be located on the wall. The display and switches can be anywhere. In our case, we will have two types of

■ **FIGURE 6.**



## PIC24 TCP/IP BASE BILL OF MATERIALS

All parts are from Mouser Electronics unless specified.

Part ID	Name	Package	Vendor	Part #
PCB		2" x 3.5"	Silver Circuits	Custom
U1	PIC24HJ128GP204	TQFP44		579-PIC24128GP204IPT
U2	MAX3232	SOIC-16		595-MAX3232ECDW
U3	AP1117	SOT89		621-AP1117Y33G-13
U4	ENC28J60	SOIC-28		579-ENC28J60-I/SO
U5	SST25VF032B	SOIC-8 Wide		804-25VF032B8IS2AF
U6	25AA02E48	SOIC-8		579-25AA02E48T-I/SN
X1	25 MHz	HC-49/US		815-ABL-25-B2F
J1	2.1 mm Power Connector	Kobiconn Pwr Connector		163-7620-E
J2	3.5 mm Stereo	Kyconn		806-STX-3000
J3-J6	Eight-pin Female Header	36-pin cut into pieces		
J7	MagJack		SparkFun	517-974-01-36
J8	Six-pin Male Header RT Angle			PRT-08534
L1	60 ohm 80 mA Ferrite Bead	SMD 1210		538-22-28-8060
D1	Amber LED	SMD 0805		436-3600-RC
D2	Green LED	SMD 0805		645-598-8150-107F
D3	Red LED	SMD 0805		645-598-8170-107F
C1-15	0.1 µF MLCC (no C12)	SMD 0603		645-598-8110-107F
C16,18	10 µF MLCC (VCAP)	SMD 0805		81-GCM188R71H104KA7J
C17	10 µF Tantalum	SMD 1206		81-GCM188R71H104KA7J
C21, C22	18 pf MLCC	SMD 0805		810-C3216X5R1A106K
C23	22 µF Tantalum	SMD 1206		80-C0805C180J5G
R1, R2	0 ohm	SMD 0805		74-293D226X96R3A2TE3
R3	2.32K 1%	SMD 0805		652-CR0805-J/-000ELF
R4, R5, R7	2K ohm	SMD 0805		71-CRCW0805-2.32K
R6, R8	330 ohm	SMD 0805		652-CR0805JW-202ELF
R9-R12	49.9 ohm 1%	SMD 0805		71-CRCW0805-330-E3
R13	10K ohm	SMD 0805		71-CRCW0805-49.9
				652-CR0805-FX1002GLF
<i>Optional Parts</i>				
X2	32,768 Hz Watch Crystal			
C19, C20	12 pf MLCC	SMD 0805		

## THERMOSTAT DAUGHTERBOARD BILL OF MATERIALS

All parts are from Mouser Electronics unless specified.

Part ID	Name	Package	Vendor	Part #
PCB		3" x 4"	Silver Circuits	Custom
U1	ULN2003	SOIC-16		595-ULN2003ADRE4
U2	SHT11	SMD	Newark	69C4848
U2 (alternate)	SHT21	SMD	Sensiron	SHT21
J1a	Terminal Strip 4 Pos	Phoenix 3.5 mm		651-1945119
J1b	Terminal Block 4 Pos	Phoenix 3.5 mm		651-1984031
J2-J5	Male Long Tail Header	36-pin cut into pieces		
J6	LCD Socket - from 40 pin DIP			517-834-03-36
J6 (Alternate)	Break-away SIP Strip			575-393640
RLY1-RLY3		SIP Relay	All Electronics	
SW1-SW6	Pushbutton Switches	Through-hole		816-9007-05-00
SW7	Tactile - Reset	SMD 7 mm		10KB012
C1	0.1 µF MLCC	SMD 0603		653-B3SN-3012P
C2, C3	1 µF MLCC	SMD 0805		81-GCM188R71H104KA7J
R1-R3	10K ohm	SMD 0805		810-C2012X7R1C105K
R4	470 ohm	SMD 0805		652-CR0805-FX1002GLF
LCDa	2x16 LCD - SPI	Through-hole		652-CR0805JW-471ELF
LCDb	Amber LED Backlight			790-EADOGM162WA
CASE	Plastic Case			790-EALED55X31A
STDOFF	4-40 3/8" Standoffs	Hex Aluminum		563-CU-389
SCREW	4-40 1/4" Screws	Nylon Pan Head		761-2055-440-AL-7
				534-9327

display and switches: the physical ones that will be part of the wall unit, and the virtual ones that will be implemented as a web page which can be used from practically anywhere.

The user interfaces – especially the physical one – went through some trial and error. The original mechanical thermostat shown in **Figure 6** has two switches along the top that control the fan and operating mode. Originally, I was going to implement these as slide switches on the wall interface. That worked fine until I tried to change the settings from the web interface. The setting would change, but then when the software looped around to read the settings of the physical slide switches, the wall thermostat settings would override the web page settings.

The web settings could not change the position of the

slide switches. I replaced the slide switches with pushbuttons that will toggle the settings of control variables in the software. The virtual pushbuttons on the web page will do the same thing. The thermostat control loop just looks at the settings of the variables and with pushbuttons to toggle them, they can be changed from anywhere.

Originally, I was going to use a Dallas Semiconductor (now MAXIM) DS18B20 digital temperature sensor, however, I wanted to include a humidity measurement. I found out about a series of temperature and relative humidity sensors made by Sensiron at the SparkFun Electronics website ([www.sparkfun.com](http://www.sparkfun.com)). Coincidentally, Sensiron was also advertising in some industry magazines and offering free samples. I requested samples direct from

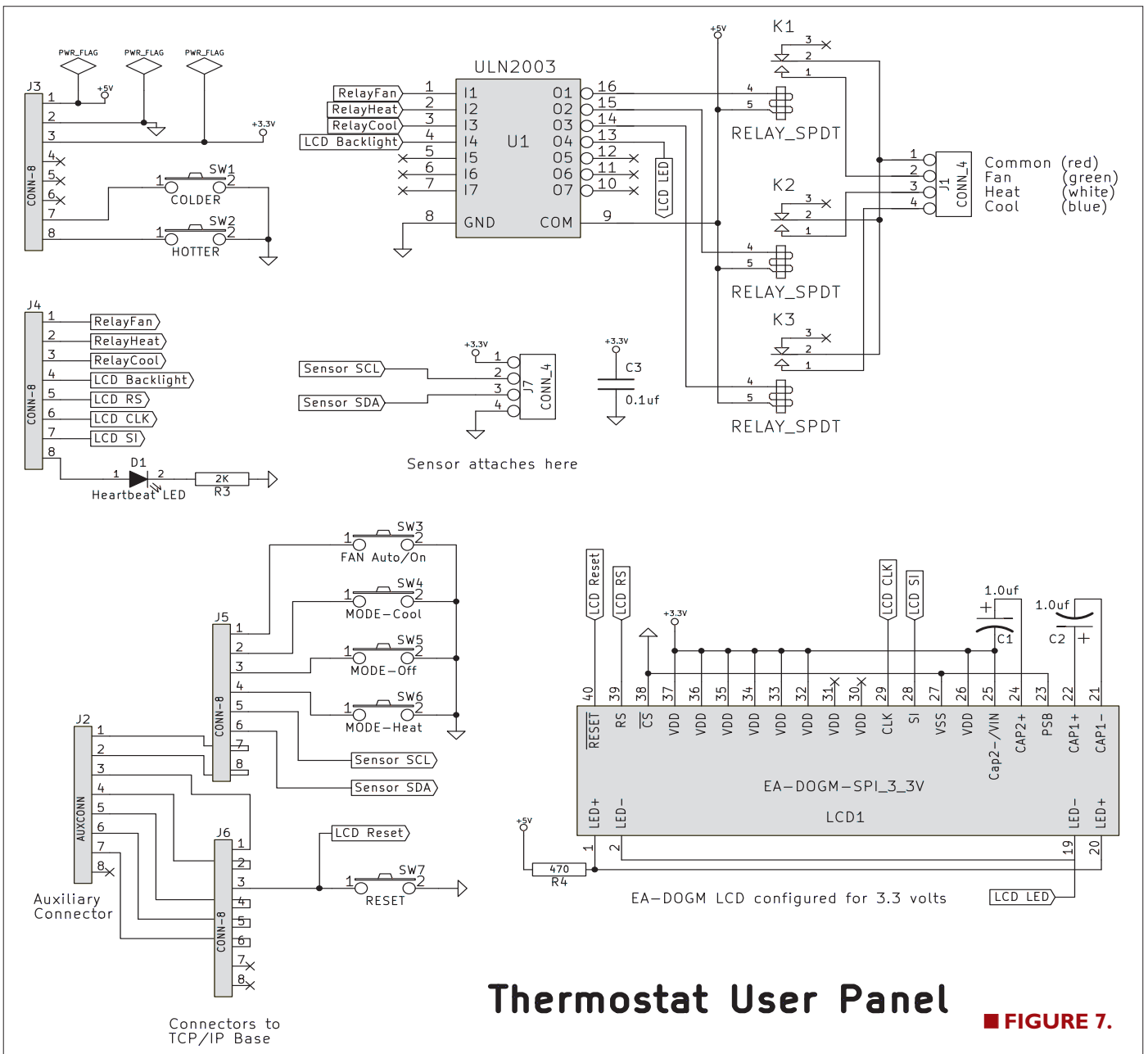



Sensiron and they sent me two of the SHT21 sensors which are 3 mm x 3 mm surface-mount devices. I also found some of the older and larger SHT11 sensors on eBay.

The Sensiron website has source code for reading the sensors which I incorporated into the project with only minor modifications. For the LCD display, I selected the Electronic Assembly DOG-M two line by 16 character display with LED backlighting. This display – which has been featured in other *Nuts & Volts* project articles – can operate on 3.3 volts and supports an SPI interface that requires only three I/O lines to connect to the microcontroller. The amber backlight is turned on for a few seconds every time a button is pushed. A ULN2003 Darlington transistor driver triggers the relays. The ULN2003 has built-in diodes for shunting the back EMF from the relays. One of the drivers controls the backlight LEDs for the LCD display, since this requires more current than the processor pins can provide.

There are four eight-pin connectors that connect to the TCP/IP base board. Mounting the Sensiron sensors directly on the PCB worked great at the workbench, but when I started to enclose the thermostat in a case, problems came up. The ENC28J60 gets warm, as does the power regulator. Unfortunately, even with plenty of ventilation holes drilled in the case, the temperature read

## REFERENCES

ENC26J60 Datasheet  
[ww1.microchip.com/downloads/en/DeviceDoc/39662c.pdf](http://ww1.microchip.com/downloads/en/DeviceDoc/39662c.pdf)

Sensiron  
[www.sensiron.com](http://www.sensiron.com)

ULN2003A  
<http://focus.ti.com/lit/ds/symlink/uln2003ai.pdf>

EA DOGM LCD  
[www.lcd-module.de/eng/pdf/doma/dog-me.pdf](http://www.lcd-module.de/eng/pdf/doma/dog-me.pdf)

SparkFun Electronics  
[www.sparkfun.com/index](http://www.sparkfun.com/index)

PCB Manufacturing  
[www.silvercircuits.com](http://www.silvercircuits.com)

All the hardware and software described in this article, along with additional detailed instructions, is available at the article download link or at [www.jgscraft.com](http://www.jgscraft.com). Microchip development tools and libraries can only be downloaded from the Microchip website. You can contact me at [jurgen@jgscraft.com](mailto:jurgen@jgscraft.com).

**\* Quality Quick Turn  
Sheet Metal Products  
&  
Precision Machined Parts**

**\* No Minimum Quantity  
Restrictions**

**\* Quote in 24 Hours  
or Less!**

**\* Several Metallic &  
Non-Metallic  
Materials in Stock**

**Visit [www.iitmetalfab.com](http://www.iitmetalfab.com)  
today for your free, no  
obligation quote!**

Integrated Ideas & Technologies, Inc.

ITAR Compliant ISO 9001:2008 AS 9100 Certified

Precision Laser Cut Stencils Sheet Metal Fabrication Precision Parts Manufacturing

Defense Aerospace Medical Aviation Communications Maritime Electronics

Serving All Industries

Metal Fabrication: [www.iitmetalfab.com](http://www.iitmetalfab.com) SMT Stencils: [www.integratedideas.com](http://www.integratedideas.com)

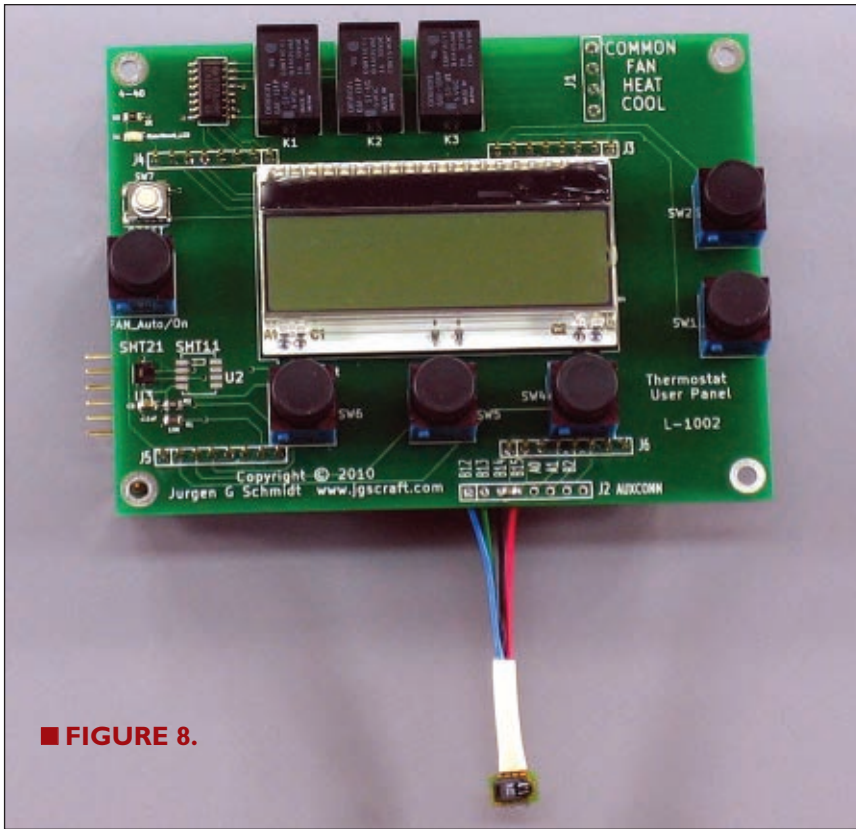

■ FIGURE 8.

a toasty 95°F even though the room temperature was only 75°F. I measured the temperature at different locations on the PCB but they were all high. The sensor needs to be outside the case. I mounted the SHT11 sensor on a pigtail and lowered it through one of the ventilation holes. Problem solved. This was not as elegant as I had originally hoped, but was effective. The updated version of the PCB has a four-position screw terminal for attaching temperature sensors which allows me to experiment easily with different sensors.

Finally, some of the leftover I/O lines are routed to an auxiliary connector. You can see the circuit diagram for the thermostat daughterboard in **Figure 7**. **Figure 8** shows the populated PCB with an attached sensor. The file ThermostatBOM.xls (included with this article's downloads) lists the part numbers and sources for both boards.

Next month, we will cover the physical connections, construction issues, and the software. **NV**



# do more wire less

# Wixel



actual size

USB. Wireless. Programmable. All for \$19.95.

The Wixel is a programmable microcontroller module with integrated USB and a 2.4 GHz radio. Write your own program or load pre-compiled, open-source apps to give your next project a wireless serial link, create a remote sensor network, and much more!



**NEW!**  
**Wixel Shield**  
**for Arduino**

 **Pololu**  
Engage Your Brain

learn more at [www.pololu.com/wixel](http://www.pololu.com/wixel)

By Joe Grand

[www.nutsvolts.com/index.php?/magazine/article/september2011\\_Grand](http://www.nutsvolts.com/index.php?/magazine/article/september2011_Grand)



# Making the

# DEFCON 18 Badge

Every summer, thousands of hackers and computer security enthusiasts descend into Las Vegas for DEFCON ([www.defcon.org](http://www.defcon.org)) — the largest and oldest continuously running event of its kind. It's a mix of good guys, bad guys, government officials, and everyone in between, all focused on having fun, sharing technical information, seeing old friends, and learning new things.

## Fifth Time's the Charm

For the fifth year in a row, I've had the honor of designing the conference badge for DEFCON. Past badges have blinked patterns of LEDs, allowed you to create your own custom scrolling text messages, turned off your television, transferred files from a SecureDigital card over infrared, and pulsed to music using Fast Fourier transforms. People have hacked the badge to become a flame thrower, an audio VU meter, a password generator, an amusement park game, an anti-surveillance system, a

blue box, and a polygraph, just to name a few.

The badges have incorporated technologies like capacitive touch sensors, jumbo LEDs, RGB LEDs, MEMS-based microphones, and microcontrollers ranging in size from tiny six-pin devices to powerful 64-pin behemoths. Badge development has happened on airplanes, in shuttle buses, on my honeymoon, in hotel rooms, and while on safari. Badges have arrived with plenty of time before DEFCON and twice they've arrived the first day of DEFCON.

The DEFCON 18 badge is a culmination of prior years' experiences, both good and bad. This article covers the engineering behind the DEFCON 18 badge and the problems I encountered along the way. Previous badge designs have been detailed in earlier *Nuts & Volts* issues.

## Badge Abstract

In a nutshell, the DEFCON 18 badge is designed to display small, 30 pixel by 30 pixel pre-defined "glyphs" on the LCD which allow the wearer to publicly share their hobbies or interests. Other features include a command-based API for controlling the LCD and a static bootloader for in-the-field firmware upgrades. A single CR2032 3V Lithium coin cell battery provides the required power and there is support for seamless power switching if the badge is connected to a computer via USB. Two pushbuttons are

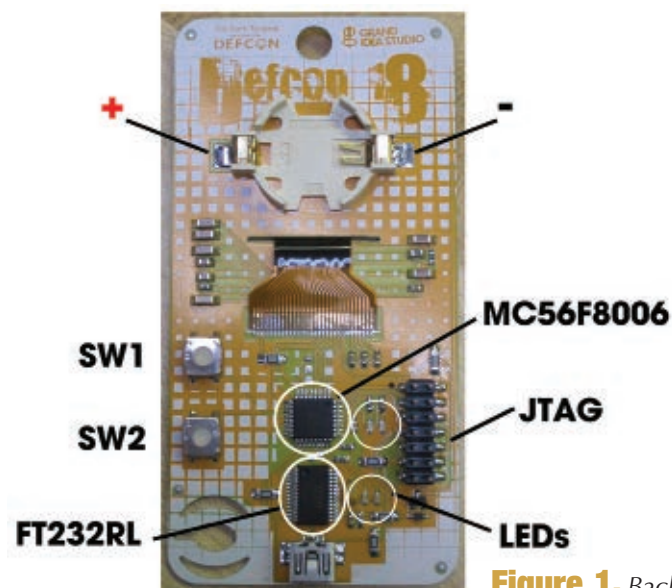

**Figure 1.** Back side of the DEFCON 18 badge showing the major subsystems.

**Table 1. Bill of Materials.**

Qty	Reference	Manufacturer	Manuf. Part #	Distributor	Distrib. Part #	Description
1	BT1	MPD	BU2032SM-JJ-GTR	Digi-Key	BU2032SM-JJ-GTR-ND	Single-cell battery holder for CR2032, SMD
1	N/A	Panasonic	CR2032	Digi-Key	P189-ND	CR2032 Lithium 3V Coin Cell Battery (225mAh)
6	C1,C6,C9,C10,C11,C15	TDK	C3216X7R1H105K	Digi-Key	445-1423-2-ND	1.0uF ceramic capacitor, 50V, X7R, 1206
6	C2,C3,C4,C5,C16,C17	Kemet	C0603C104K8RACTU	Digi-Key	399-1096-2-ND	0.1uF ceramic capacitor, 16V, X7R, 0603
1	C7	Kemet	T491A106M016AT	Newark	57K1640	10uF capacitor, 20%, 16V, tantalum, size A
1	C8	Taiyo Yuden	UMK212B7474KG-T	Digi-Key	587-1288-2-ND	0.47uF ceramic capacitor, 50V, X7R, 0805
2	C12,C13	Taiyo Yuden	TMK212BJ225KG-T	Digi-Key	587-1292-2-ND	2.2uF ceramic capacitor, 25V, X5R, 0805
1	C14	Kemet	C0603C475K8PACTU	Digi-Key	399-5503-2-ND	4.7uF ceramic capacitor, 10V, X5R, 0603
4	D1,D2,D3,D4	Avago	HSMH-C192	N/A	N/A	LED, Red, 0603, 1.8Vf, 17mcd @ 20mA
1	D5	ON Semiconductor	MMDL914T1G	Mouser	863-MMDL914T1G	Diode, Switching, 100Vr, 1Vf @ 10mA, 5uA Ir @ 75V, SOD-323
1	LCD1	Kent Displays	1594101208	N/A	N/A	LCD, 128x32 Reflex Graphic Display Module
1	N/A	GM Nameplate	N/A	N/A	N/A	3M 468MP adhesive tape for LCD attachment, 1" x 1/2" strips
1	P1	Hirose	UX60SC-MB-5ST(80)	Digi-Key	H11671TR-ND	Connector, Mini-USB Type B, R/A, 5 position, SMD
1	Q1	Fairchild	FDN340P	Digi-Key	FDN340PTR-ND	Transistor, MOSFET, P-Channel, 20V, 2A, SSOT3/SOT23
1	R1	Yageo	RC0603FR-07200RL	Mouser	603-RC0603FR-07200RL	200 ohm, 1%, 1/10W, 0603
5	R2,R3,R4,R5,R6	Panasonic	ERJ-3GEYJ102V	Digi-Key	P1.0KGTR-ND	1k, 5%, 1/10W, 0603
2	SW1,SW2	C&K	KSC201JLFS	Digi-Key	401-1756-2-ND	SPST tactile momentary switch, 120gf, 6.2 x 6.2mm, J-Lead
1	U1	Freescale	MC56F8006VLC	Avnet	N/A	Microcontroller/Digital Signal Controller, LQFP32
1	U2	FTDI	FT232RL	Mouser	895-FT232RL	USB-to-Serial UART Converter, SSOP28W
1	N/A	N/A	N/A	Avnet	N/A	Microcontroller programming service
6	W1,W2,W3,W4,W5,W6	Panasonic	ERJ-8GEY0R00V	Digi-Key	P0.0ETR-ND	Jumper, 0 ohm resistor, 1/4W, 1206
1	PCB	e-Teknet	DC18	N/A	N/A	PCB (fabrication, laser, assembly, test)

available for user interface control.

The badge is based around a Freescale MC56F8006 16-bit digital signal controller and a 128 by 32 reflective cholesteric LCD by Kent Displays. The design is meant to be stark and simple. It measures a svelte 50 mm wide by 100 mm long, and all the components – with the exception of the LCD – are mounted on the back of the badge (Figure 1).

## Hardware Design

Refer to the schematic (Figure 2) and bill of materials (Table 1) for specific component information.

### Microcontroller

As mentioned, the heart of the badge, U1, is the

**Figure 2. DEFCON 18 badge schematic.**

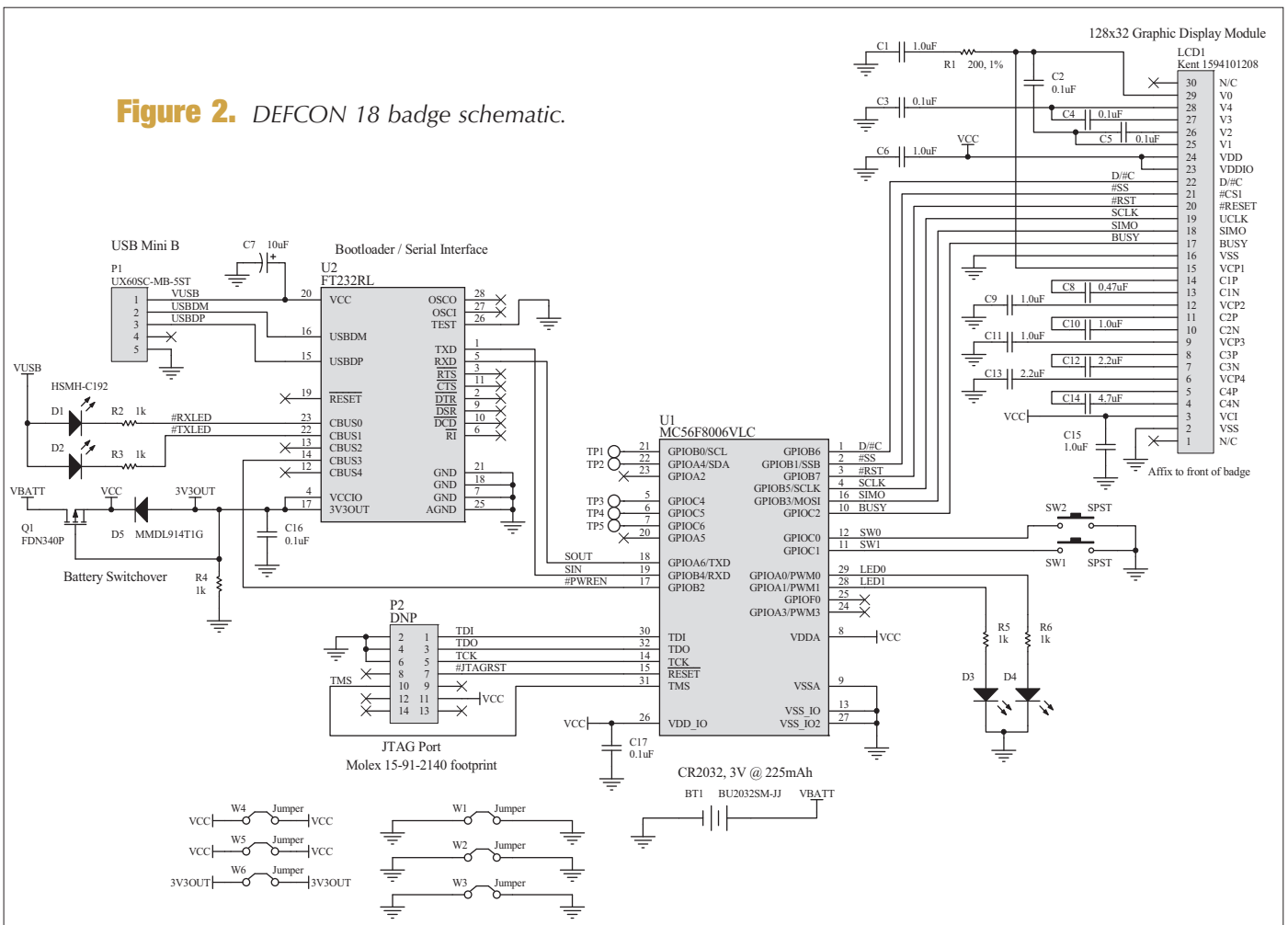

Freescale MC56F8006 digital signal controller ([www.freescale.com/webapp/sps/site/prod\\_summary.jsp?code=MC56F800x](http://www.freescale.com/webapp/sps/site/prod_summary.jsp?code=MC56F800x)) which combines the processing power of a digital signal processor with the functionality and peripherals of a microcontroller.

The MC56F8006 is part of the 16-bit 56800/E family and is very powerful. It features (among other things) 16 KB of Flash, 2 KB of RAM, a six-channel PWM module, 18-channel 12-bit analog-to-digital converter, two programmable gain amplifiers, three analog comparators, programmable interval timer, serial communication interface/UART, real time counter, I<sup>2</sup>C and SPI ports, and up to 22 general-purpose I/O lines — all crammed into a 32-pin LQFP with a 7 mm x 7 mm footprint. Other package types support differing numbers of peripherals and features. The part supports 1.8V to 3.6V operation and clock speeds up to 32 MHz. For the DEFCON 18 badge, it is configured to use the on-chip oscillator at 8 MHz.

Source code was developed in C using Freescale's CodeWarrior for 56800/E Digital Signal Controllers Special Edition ([www.freescale.com/webapp/sps/site/prod\\_summary.jsp?code=CW-56800E-DSC](http://www.freescale.com/webapp/sps/site/prod_summary.jsp?code=CW-56800E-DSC)) which is free for code sizes up for 64 KB.

## LCD

The pièce de résistance is a 128 pixel by 32 pixel reflective cholesteric LCD (ChLCD) by Kent Displays ([www.kentdisplays.com](http://www.kentdisplays.com)). Known as the Reflex Graphic Display Module, this bi-stable display was originally designed for use in Verbatim InSight USB portable hard drives and has since been made available to other customers.

I had wanted to use some sort of LCD on the DEFCON badge for the past few years, but the price point just wasn't right and I had concerns about reliability and fragility of the devices as they bounced around on people's necks. I had seen a demonstration of Kent

Displays' ChLCD technology at the Embedded Systems Conference in 2009 and thought it deserved a closer look.

A key feature of the display is that it requires no power or refresh to retain the image on the screen, making it ideal for battery life-challenged applications like the badge. I wanted to show off this feature to conference attendees in a way that all could appreciate, even if they didn't understand the underlying technology. As the final step in the test procedure used during badge manufacturing, I had the DEFCON logo displayed on the LCD. So, when the badges were handed out to attendees during conference registration, they'd see the logo even though no battery was in place yet.

The device has a viewing size of approximately 1.3" long by 0.47" wide by 0.06" thick and has a resolution of 118 DPI (dots per inch). The LCD is controlled via an SPI-like slave serial interface and only a handful of external capacitors are needed to set up the drive voltages. Pseudocode to drive the display is provided in the LCD datasheet ([www.kentdisplays.com/services/resources/datasheets/25138B\\_128x32COG.pdf](http://www.kentdisplays.com/services/resources/datasheets/25138B_128x32COG.pdf)) and was easily ported to my C environment.

This display requires that the entire screen is updated if any contents on the screen need to change, even if it is just a single pixel or line. A full screen update takes approximately 1.7 seconds at room temperature. This obviously precludes any sort of continually-updated animations, but the many advantages of this technology for our design far outweighed what I found to be the few disadvantages.

DEFCON was the first customer to use the display in an exposed "naked" fashion by affixing the LCD module directly to a PCB. For most products using an LCD, some sort of housing or bezel is designed around the display to hold it in place, protect it, and hide its unsightly parts. I felt that showing off the entire device was more interesting and made for a nice look. I evaluated a number of different adhesives intended for use on glass and aluminum, and ultimately selected the 3M 468MP adhesive transfer tape due to its adhesion and shear properties, thickness, and common use in and around electronic devices. The adhesive is sold in a large panel, so I had GM Nameplates die-cut the panel into thousands of 1" by 1/2" strips which were then applied to each LCD during the badge assembly process. With the LCD mounted on the front side of the badge, its 0.87" wide flat flex cable slid through a small slit and was hand soldered to its mating footprint on the backside of the badge.

## Seamless Power Switching

One of my favorite aspects of the DEFCON 18 badge design is the seamless power switching between the CR2032 coin cell battery and USB power. This allows the badge to operate continuously if it is connected to a computer, regardless if a battery is in place or not.

The theory of operation for this feature is as follows: The P-channel MOSFET, Q1, is ON by default via the R4 pulldown resistor, connecting VBATT to VCC. D5 prevents VBATT from back-powering U2 via 3V3OUT. When the

## Hidden Features

Since badge development normally happens behind closed doors and the badge's functionality is only revealed once the conference begins, I thought it would be fun to involve the hacker community in some fashion *before* they get to DEFCON.

During the firmware development phase of the project, I released a public "Call for Integration" and invited people and groups to hide functionality or chunks of data within the badge that could be used (if discovered) by attendees as part of a contest or giveaway. I received a few dozen responses and chose seven of the best to include in the badge. The folks whose submissions were selected were given just enough badge detail to enable them to create their desired data or graphic. Data ranged from a short string of text included in the badge's source code to puzzles for a particular DEFCON contest displayed on the LCD to a 1600 byte program stored in an unused area of Flash ROM within the MC56F8006.

I will leave the discovery of the hidden features as an exercise for badge owners or those who want to peruse the source code, but I at least wanted to mention that they exist!

USB connection is made, 3V3OUT (a regulated 3.3V @ 25 mA output from U2) goes HIGH which turns OFF Q1, isolating the battery from the circuit. The body diode of Q1 prevents the battery from getting reverse fed by 3V3OUT, though there is a measurable leakage in the nA range that is within the battery's allowable limits.

During battery-powered operation, VCC is at the battery voltage of 3V (VBATT). During USB-powered operation, VCC is ~2.7V. This is caused by 3V3OUT (3.3V) across D5 which has a voltage drop of ~0.6V @ 10 mA.

**Figure 3** is an oscilloscope screenshot showing VBATT, 3V3OUT, and VCC voltage levels during a battery-to-USB power switch.

Alternatively, the USB-to-battery switchover when USB power is removed from the badge also provides seamless operation. There is a 0.2V droop on VCC lasting almost 4 mS as 3V3OUT goes LOW and Q1 turns ON, but VCC then rises to VBATT.

## Battery Life

For the fourth time in five years of DEFCON electronic badge development, I selected the CR2032 Lithium coin cell as the battery source. This slim, low cost battery has a nice current capacity for its size (20 mm in diameter) of approximately 225 mAh to 2V. Even though the cell can handle 3 mA continuous discharge and upwards of 10 mA pulse current, the lithium battery chemistry works best for applications requiring very low continuous discharge current (e.g., tenths of a mA) over months or years of use.

With designing any portable device, one challenge is meeting your desired battery life specifications. For the badge, my intent was to have a single battery last at least seven days in order to cover the entire weekend conference and a few days prior for those who received their badges during "early bird" registration. To reduce power consumption and prolong battery life, both the MC56F8006 and the LCD enter sleep modes when their functionality isn't required.

**Table 2** shows the current consumption for the badge's three modes. Assuming the badge was not used and just left in idle mode:

- 24 hours @ 0.7 mA = 16.8 mA per day
- CR2032 typical current capacity (down to 2V cell voltage) = 225 mAh
- Estimated battery life = 225 mAh / 16.8 mA per day = 13.4 days

Mode	CURRENT @ VCC = 3V
Idle (Wait)	0.7 mA
Active (LCD update)	8.3 mA for 930 mS
Serial Port TX	6.7 mA

**Table 2.** Current consumption measurements for the three badge modes.

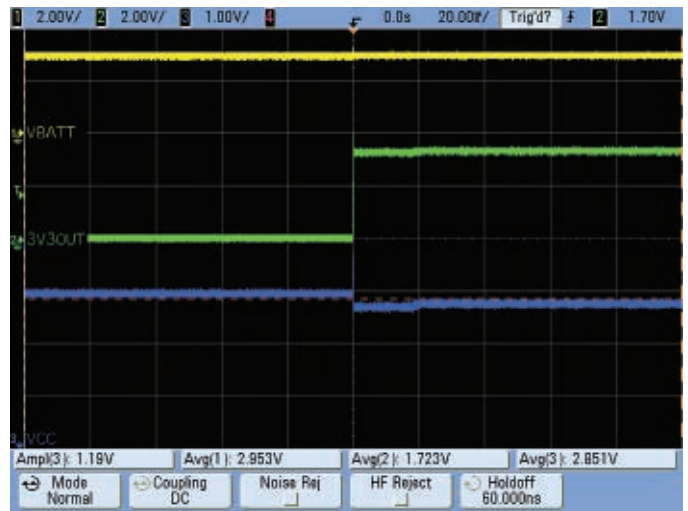

**Figure 3.** Oscilloscope screenshot of battery-to-USB power switch. Note the 50  $\mu$ S glitch on VCC as the level drops from 3V (VBATT) to 2.7V (3V3OUT minus the voltage drop of D5).

Assuming a more practical badge usage of one hour in the active state and 23 hours idle:

- 1 hour active @ 8.3 mA = 8.3 mA
- 23 hours idle @ 0.7 mA = 16.1 mA
- CR2032 typical current capacity (down to 2V cell voltage) = 225 mAh
- Estimated battery life = 225 mAh / 24.4 mA per day = 9.2 days

You might think that only one hour of active use would be too low of an estimate for someone actually using the badge, but the badge only needs to be active while the screen is being updated which takes only 930 mS. Since the LCD doesn't require any power to keep its contents on the screen and the MC56F8006 is sleeping and waiting for an external interrupt from one of the two buttons or a USB connection, the badge isn't really doing much most of the time. To put it another way, one hour of active use corresponds to 3,871 full screen updates.

The serial port TX mode occurs when the serial port is transmitting debug information or being used in bootloader mode. We can ignore this mode during battery power consumption estimates, since the badge typically only transmits when the USB connection to a PC is made, in which case power will be provided by the computer and not the battery.

## Badge Operation

### Glyph Selection

The core functionality of the badge is to display small, 30 pixel by 30 pixel glyphs on the LCD. There are 11 pre-defined icons and four can be displayed on the screen at one time. This allows the wearer of the badge to publicly



**Figure 4.**  
*The badge allows you to display four of 11 possible glyphs at a time on the LCD to indicate your hobbies or interests.*

share their hobbies or interests. Conference attendees can then walk around and look at other people's badges to see if their interests match. If so, they may decide to strike up a conversation. To enter the Glyph Selection mode, you press SW2 from the DEFCON logo screen. SW1 and SW2 are then used to cycle through the glyphs. Pressing SW1 and SW2 at the same time will select the glyph. This process is repeated for each of the four available glyph locations on the LCD.

**Figure 4** shows the glyphs, starting from the upper-left corner: drinking, gambling, videogames, electronics/soldering, lockpicking, looking for love, music, networking, software, telephony, and wireless. **Figure 5** shows a close-up of my personal badge's screen with my four selected glyphs.

## LCD Control API

In the hopes of attracting more software hackers or those with limited electronics knowledge to poke around with the badge, I created an LCD Control API (Application Programming Interface) in which the LCD can be written to or erased using simple serial commands sent at 9600 bps through the badge's USB virtual serial port (provided by U2, the FTDI FT232RL USB-to-serial UART converter). Using scripts or a terminal program such as HyperTerminal or CoolTerm, the user can display custom graphics or text on the LCD.

To enter the LCD Control API mode, the badge must be connected to a computer via USB and a single '#' character should be sent. The badge will return a welcome string in ASCII.

The API supports four commands:

- 'C' = Clear frame buffer (which is stored in MC56F8006 RAM on the badge)
- 'L aa bb vv' = Load data vv into frame buffer location aabb  
 Ex: L 00 01 0A will write value 0x0A to location 0x0001  
 Valid locations: 0x0000 to 0x01FF  
 Memory map available on page 9 of the LCD datasheet
- 'U' = Update LCD w/frame buffer contents
- 'X' (or power cycle) = Exit API mode

Note that while the command bytes are printable ASCII characters, the data and location values within command L are raw bytes in hexadecimal. The badge will return ACK (':') after a valid command has been received and processed.

A few conference attendees quickly created tools to send a bitmap image to the badge, such as Brad Isbell's DEFCON 18 badge Image Writer ([www.musatcha.com/software/DC18BadgeImageWriter/](http://www.musatcha.com/software/DC18BadgeImageWriter/)). The API was widely used throughout the weekend and I chuckled as I saw all of the funny messages and graphics displayed on people's badges.

## Bootloader

In order to provide a mechanism for attendees to easily load new firmware into the MC56F8006's Flash memory to aid in badge hacking and customization, I implemented a static bootloader based heavily on Freescale's AN3814 application note. The bootloader communicates via U1's RXD and TXD pins at 9600 bps through U2 and is enabled when both SW1 and SW2 are held down at power-on. LEDs D3 and D4 will illuminate, indicating that the badge is in bootloader mode awaiting data, and the virtual COM port will appear on the host computer.

The beauty of the bootloader is that no specialized hardware or development tools are needed, so it lowers the barrier to entry for new hackers and people looking to experiment with the badge. During this mode, one can load firmware onto the badge by simply uploading the ASCII text-based S-Record file of the compiled program (generated by CodeWarrior) using a simple terminal application. Load time for a full 16 KB program is around 90 seconds.

Here is an example of the text output during bootloader usage:

```
Serial bootloader started.
Waiting for application S-Record.
PROGRAM&DATA*****
Download complete.
Starting user application.
Welcome to the DEFCON 18 Badge.
```

If the firmware gets corrupted through a faulty programming or runtime operation, an unpopulated 2x7 header is available for the MC56F8006's JTAG interface (TDI, TMS, TDO, TCK, and RST). The JTAG interface can be used for complete firmware reprogramming (including the bootloader) and full debugging using CodeWarrior and the USB TAP hardware ([www.freescale.com/webapp/sps/site/prod\\_summary.jsp?code=USBTAP](http://www.freescale.com/webapp/sps/site/prod_summary.jsp?code=USBTAP)).

## Laser Engraving

The badge is the face of DEFCON worn by every attendee. Almost as important as the electronic functionality of the badge is what it looks like.

In my quest to incorporate a never-been-done-before artistic element, I decided to use 0.040" thick aluminum substrate printed circuit boards and laser engrave



DEFCON artwork onto the front side. Laser engraving was a feat questioned by e-Teknet – my trusted fabrication and assembly facility based in China that I have worked with for many years. They were particularly concerned with how the reliability and quality would be affected after the boards were handed off to an outside vendor for engraving and then returned to them for assembly and test.

To make things more difficult, there are many facilities that will perform laser engraving services on marketing and promotional items like glassware, wooden drink coasters, or metal keychains, but very few were willing to risk working with an atypical material like a circuit board. After some negotiating, e-Teknet agreed to handle the subcontracting to the laser engraving facility which was conveniently also located in China.

Seven unique badges were created to denote the different types of DEFCON attendee: Human, Goon, Press, Speaker, Vendor, Contest Organizer, and Uber (awarded to the winners of official DEFCON contests). Neil Kronenberg, the resident DEFCON artist, used his mastery of the pen to create compelling artwork corresponding to each attendee type. When all seven badges are placed side by side in the correct order, a landscape image appears as a complete portrayal of the DEFCON conference (Figure 6).

Seven different soldermask colors were used on the back side to help DEFCON staff quickly identify the

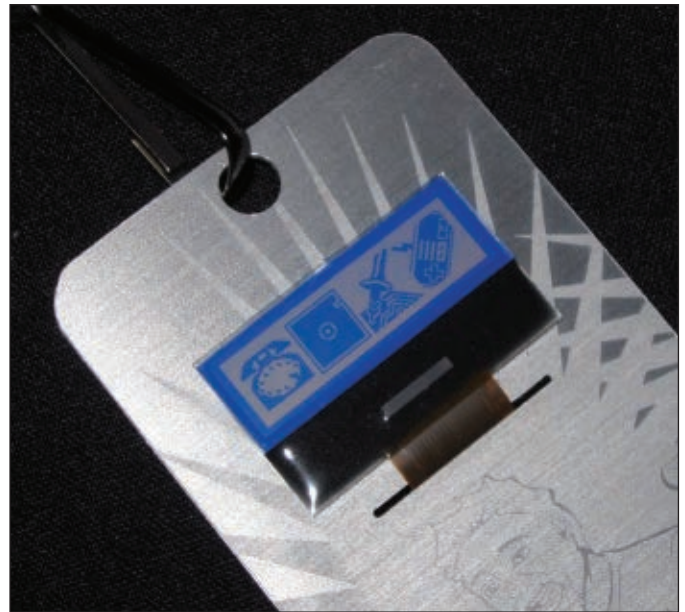

**Figure 5.** Close-up of my personal badge showing glyphs.

attendee type (Figure 7). To help with the problem of a Human simply painting their white badge red to gain Goon status, the first letter of each attendee type (for example, “H” for Human) was routed out of the aluminum substrate in the bottom corner.



## The Lynxmotion Servo Erector Set

**Imagine it... Build it... Control it!**



**Biped BRATs**

With our popular Servo Erector Set you can easily build and control the robot of your dreams. Our interchangeable aluminum brackets make the ultimate precision mechanical assemblies. Our Visual Sequencer for SSC-32 provides powerful PC, Atom, or BS2 based control.

Visit our huge website to see our complete line of aluminum and Lexan based robot kits, electronics, and mechanical components.



**Johnny 5**



**Round 3DOF Hex**



**A4WD1**



**Mini 2DOF Hex**



**Bipeds**



**AL5C Arm**

[www.lynxmotion.com](http://www.lynxmotion.com)

**Toll Free: 866-512-1024**

Images represent a fraction of what can be made!

The SES now has 143 unique components!

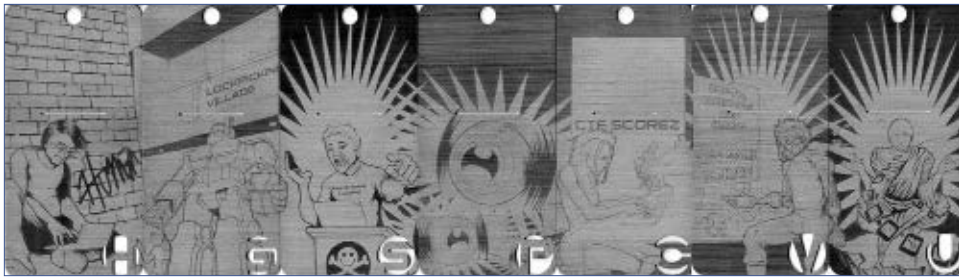

**Figure 6.** When placed side by side, the seven badges form a beautiful landscape image. (LCDs removed to show unobstructed artwork).

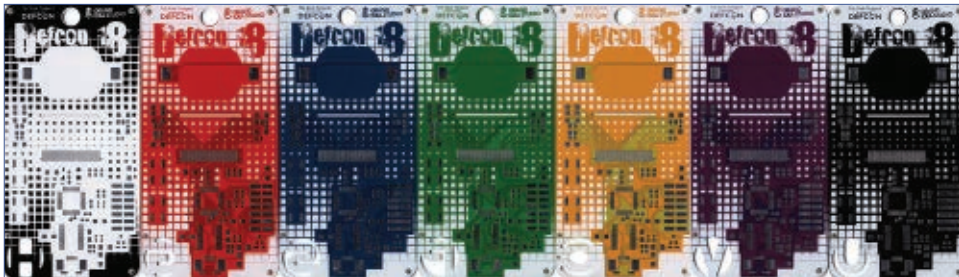

**Figure 7.** The seven different soldermask colors shown on unpopulated badges.

Joe Grand is an electrical engineer, hardware hacker, and president of Grand Idea Studio, Inc. ([www.grandideastudio.com](http://www.grandideastudio.com)), where he specializes in the design and licensing of consumer products and modules for electronics hobbyists. He can be reached at [joe@grandideastudio.com](mailto:joe@grandideastudio.com).

## Until Next Time

A lot has happened since I designed DEFCON's first electronic badge five years ago.

Within the hacker community, conferences and parties using electronic badges has become the norm. What used to be a unique exception is now the rule. While this is a fantastic trend as it shows the strength and popularity of hobbyist electronics, I'm one who likes to *buck* trends and do things that people haven't done before. You never know what next year will bring, but as a hacker, you should always expect the unexpected!

All engineering documentation and resources for the DEFCON 18 badge are available on my website at [www.grandideastudio.com/portfolio/defcon-18-badge/](http://www.grandideastudio.com/portfolio/defcon-18-badge/). **NV**

mcgillwarehouse www.uu77.com

**Digital Multimeters** Quality products at low prices.

Large selection and best pricing on Light, Sound, Temperature, Humidity, Gas, Electric, Wind and Pressure Meters

No order minimum and volume discounts for wholesalers.

**5% OFF** www.uu77.com

PURCHASE OF \$20 OR MORE  
ENTER COUPON CODE **DMMS** at checkout

**Learn Electronics**

**Build 100's of Kits**

**Do Robotics**

**GSSTechEd.com**  
**1-800-422-1100**

# I<sub>2</sub>I CONTROLS

Tomorrow's programming revolution,  
starts today!

The choice is yours to make

```
//-----  
*  
SSD1963_8-BIT  
PROGRAM FOR WRITING TO NE-  
WHAVEN DISPLAY 5.7" TFT  
*/  
//-----  
DELAY_MS(100);  
WRITE_COMMAND(0x01); //SOFTWARE RESET  
WRITE_COMMAND(0x01);  
WRITE_COMMAND(0x01);  
DELAY_MS(10);  
COMMAND_WRITE(0x0E,0x01); //START PLL  
COMMAND_WRITE(0x0E,0x03); //LOCK PLL  
WRITE_COMMAND(0x80); //SET LCD MODE SET TFT 18BITS  
MODE  
WRITE_DATA(0x0C); //SET TFT MODE & HSYNC+VSYNC+DEN  
MODE  
WRITE_DATA(0x80); //SET TFT MODE & HSYNC+VSYNC+DEN  
MODE  
WRITE_DATA(0x01); //SET HORIZONTAL SIZE=320-1 HIGH-  
BYTE  
WRITE_DATA(0x3F); //SET HORIZONTAL SIZE=320-1 LOWBYTE  
WRITE_DATA(0x00); //SET VERTICAL SIZE=240-1 HIGHBYTE  
WRITE_DATA(0x0F); //SET VERTICAL SIZE=240-1 LOWBYTE  
WRITE_DATA(0x00); //SET EVEN/ODD LINE RGB SEQ.=RGB  
COMMAND_WRITE(0xFO,0x00); //SET PIXEL DATA I/F  
FORMAT=8BIT  
COMMAND_WRITE(0x3A,0x60); // SET R G B FORMAT = 6 6 6  
WRITE_COMMAND(0xE6); //SET PCLK FREQ=4.94MHZ ; PIXEL  
CLOCK FREQUENCY  
WRITE_DATA(0x02);  
WRITE_DATA(0xFF);  
WRITE_DATA(0xFF);  
WRITE_COMMAND(0xB4); //SET HBP,  
WRITE_DATA(0x01); //SET HSYNC TOTAL 440  
WRITE_DATA(0xB8);  
WRITE_DATA(0x00); //SET HBP 6B  
WRITE_DATA(0x44);  
WRITE_DATA(0x0F); //SET VBP 1.6=1.5+1  
WRITE_DATA(0x00); //SET HSYNC PULSE START POSITION  
WRITE_DATA(0x00);  
WRITE_DATA(0x00); //SET HSYNC PULSE SUBPIXEL START POSI-  
TION  
WRITE_COMMAND(0xB6); //SET VBP,  
MORE
```



; USING NEWHAVEN DISPLAY  
WITH SSD1963 CONTROLLER

; DO DATE AND TIME

SETIO G, 0XFO00 ;SET LOCATION FOR DISPLAY  
SETIO U, 0XFA00 ;SET LOCATION FOR USB DRIVE  
LOAD "FONT.HEX" ;GET FONT TABLE FROM USB  
SETGLCD I ;INITIALIZE THE GRAPHICS LCD  
SETGLCD C ;CLEAR THE DISPLAY  
SETGLCD D1 ;SELECT LARGE FONT

DO

SETGLCD P,(100,200);SET CURSOR POSTION

; DISPLAY TIME

GLCDOUT USING(2),!H,"",!M,"",!S," "

; DISPLAY DATE

GLCDOUT USING 2),!MO,"",!D,"",!Y

UNTIL S=1

; ALL DONE

Choose your path at



[www.i2icontrols.com](http://www.i2icontrols.com)

■ BY L. PAUL VERHAGE

# PROGRAMMING THE ULTRALIGHT NEAR SPACE FLIGHT COMPUTER

The UltraLight has a split personality. One side — its tracker side — reformats GPS sentences into position reports for transmission over amateur radio. Because of it, chase crews can follow the near spacecraft and recover it at the end of its mission. Its other side — the PICAXE side — operates experiments, as well as records their results. It's the reason we launch near spacecraft in the first place. The previous column described how to program the tracker side, so this time we'll cover the PICAXE side.

## MEMORY

The UltraLight takes advantage of the memory and I/O features found in the PICAXE-28X1. First, let's look at memory. There are actually three types of memory in many of the PICAXE microcontrollers. The type most *Nuts & Volts* readers are familiar with is the PICAXE-28X1's 4K of EEPROM memory. This is where the UltraLight's flight program is stored. Data can also be stored in this EEPROM along with the flight code, but with a 32 Kb memory bank onboard the UltraLight, there's no need to store data in the PICAXE. Now, a limit of 4,096 bytes for flight code may sound small. However, a program large enough to operate four analog sensors, a Geiger counter, two cameras, a servo, and GPS receiver requires less than 1/5th of that memory.

The next type of memory is the random access memory or RAM. RAM is actually broken into two types. There's the 28 bytes of RAM (addressable as B0 to B27 or W0 to W13) for the logical and mathematical manipulation of data. This is the RAM used by commands like FOR/NEXT and LET. Then there's an additional 95 bytes of temporary storage that can't be accessed directly by name. Instead, the POKE command writes variables into this memory and the PEEK command reads it back out. Both the POKE and PEEK commands reference specific bytes by their numerical

address. So, for example, the command **PEEK B0,100**, stores the value currently located in B0 to a byte located at position 100. This second type of RAM memory is useful when a separate, protected copy of the variable values is required. I like to think of it as keeping a second accounting book. Remember that data stored in RAM memory is lost when power is removed from the UltraLight. Therefore, anything important must be written into EEPROM.

In addition to the general-purpose and storage memory described above, there's a third type of memory consisting of an additional 128 bytes called scratch pad memory. Like the storage variables above, data in scratch pad memory can't be referenced directly by name either; it's addressed at the byte level by its address. However, instead of POKE and PEEK, memory in scratch pad memory is accessed using the READ and WRITE commands. You'll see that the UltraLight makes extensive use of scratch pad memory because of the GPS receiver.

To use the scratch pad memory for GPS sentences, the PICAXE-28X1's hardware serial port must first be configured. The following command sets it up for the GPS receiver's 4800 baud, inverted sentences:

```
hsersetup b4800_4,%00
```

Use the following command to receive 128

characters of GPS data in scratch pad memory. The command waits for the letter "W" before recording GPS sentences:

```
hserin [4000,Bad_GPS],0,1,("W")
```

Depending on the GPS receiver configuration, you may need several HSERIN commands to isolate the specific GPS sentence desired.

Now that a GPS sentence (we hope the correct one) is loaded into scratch pad memory, the PICAXE parses the data to locate the information of interest. One way to determine if the GPS sentence in scratch pad is the GPGGA sentence (the one I use the most often) is to look for the meters symbol (M) some 40 characters into the sentence. If the GPS does not have a lock on satellites, then the time field in the GPGGA sentence remains blank which moves M closer to the beginning of the sentence. I've started using the following code to determine if the GPS has a lock:

```
Scan_GPS:
  for b2 = 40 to 55
    get b2,b0
    if b0 = "M" then Confirmed_Good_GPS
  next
  goto GPS
```

The range in which to search for the M character can be tightened up if you know the format of your GPS receiver's GPGGA sentence. Alternatively, one could write code that checks to see that the first six characters after GPGGA are digits (in other words, the time field is filled). Since GPS sentences are made up of ASCII characters, a way to convert an ASCII digit into binary form is needed if the UltraLight is to use fields like the altitude. The following example demonstrates one way to convert the ASCII altitude into a word sized variable. A similar conversion could be used to convert most of the ASCII time into a word variable:

```
Get_Altitude:
  get 42,b0,b1,b2,b3,b4,b5
  b0 = b0 - 48
  Reading = b0
  if b1 = 46 then Altitude_Done
  b1 = b1 - 48
  Reading = Reading * 10
  Reading = Reading + b1
  if b2 = 46 then Altitude_Done
  b2 = b2 - 48
  Reading = Reading * 10
  Reading = Reading + b2
  if b3 = 46 then Altitude_Done
  b3 = b3 - 48
  Reading = Reading * 10
  Reading = Reading + b3
  if b4 = 46 then Altitude_Done
```

```
b4 = b4 - 48
Reading = Reading * 10
Reading = Reading + b4
```

The code reads six ASCII characters out of scratch pad memory and then converts each into its binary representation by subtracting 48 from its ASCII value. Each digit is added into the final altitude variable by first multiplying the altitude by 10. This is essentially shifting the altitude variable in base 10 before adding the next digit to the altitude.

---

## THE ULTRALIGHT MEMORY BANK FOR DATA

---

Before discussing the input and output of the PICAXE-28X1, let's look at the EEPROM memory for flight data. The UltraLight's 24LC256 EEPROM memory uses fast (400 kHz) I<sup>2</sup>C communications and double byte (one word) addressing. The command that configures communication between the 24LC256 and the PICAXE-28X1 must be executed once before the memory can be accessed:

```
i2cslave %10100000,i2cfast,i2cword
```

Since the EEPROM is addressed by two bytes, data must be stored one word — or two bytes — at a time. The following code writes the values of bytes B6 and B7 into EEPROM. The memory address of the write is tracked with the word W0:

```
Store_Data:
  writei2c W0,(B6,B7)
  pause 10
  W0 = W0 + 2
  return
```

After recovery, the data stored in EEPROM is read out by the following code:

```
Download:
  sertxd ("Start,")
  for W0 = 0 to 4091 step 2
    readi2c W0,(B2,B3)
    sertxd (#W1, ",")
  next
```

Since the EEPROM is addressed by the word, the FOR-NEXT loop steps through the address by twos. The subroutine also assumes there are 4,091 bytes of data recorded in memory; you'll need to change this based on the flight. Mission data is downloaded over the programming port with the PICAXE Editor's built-in terminal program. You'll find the terminal program under PICAXE - Terminal. Be sure to set the Terminal for a download speed of 4800 baud.



## INPUT/OUTPUT PORTS

Now, let's look at the inputs and outputs to the PICAXE-28X1.

### Analog Port

For the collection of sensor data, the UltraLight has four channels (ADC0 to ADC3) in the Analog port. Each channel digitizes (that is, converts analog voltages into their digital values) sensor voltages in the range of zero to five volts. The commands READADC and READADC10 permit the PICAXE to digitize voltages with resolutions of either eight bits (19.5 mV per bin), or 10 bits (4.8 mV per bin, or four times the resolution of the READADC command), respectively. Each channel of the Analog port provides five volts and ground to each of its experiments. This means that in most cases, experiments will not require a separate power supply. You literally plug and play the experiment.

The following code digitizes sensor voltages into 1,024 bins (10 bits of resolution). Each reading is then stored into EEPROM in one word records. More data could be packed into EEPROM if two eight-bit analog readings are stuffed into a word and then stored, but that would leave out the third sensor voltage. Perhaps it could be stuffed into a word along with a digital sensor reading:

```
Analog:
  for B2 = 0 to 2
    readadc10 B2,W0
    gosub Store_Data
  next
return
```

### Digital Port

Not every experiment produces an analog voltage. Therefore, the UltraLight also has a Digital port for sensors like Geiger counters. In the case of the Geiger counter, the signal is a digital pulse at the detection of each cosmic ray. For this example, the PICAXE counts the number of "clicks" over a fixed time interval. The Aware Electronics RM-60 Geiger counters I typically use produce a 20 microsecond long pulse at each detection. The PICAXE counts the number of pulses for 10 seconds, and I later multiply the result by six in a spreadsheet. Here's an example of counting cosmic rays with the Digital port:

```
Cosmic_Ray:
  count 0,10000,b2
  gosub Store_Data
return
```

As with the Analog port, every channel in the Digital port provides experiments with five volts and a ground, relieving the designer of creating a power supply for the experiment. The channels in the Digital port are input 0 to input 2.

### Servo Port

There are times when devices must be opened, closed, or oriented during a near space mission. For those cases, the UltraLight also has a Servo port with two channels. There is a small risk that servos could drain batteries during a mission. There's also a tiny risk that the operation of a servo will create voltage jitters that interfere with the rest of the UltraLight. For those reasons, the Servo port uses a battery pack separate from the main battery pack. The servo channels are output 0 and output 1.

The following code rotates a servo on channel 0 to a position of 110 (close to the midpoint for most servos):

```
servo 0,110
```

The range of a servo's rotation depends on the servo, but you can usually expect it to be from 75 to 225. If you are going to drive a servo close to its limits, first test it by gradually increasing the position value in the servo command.

### Camera Port

Each of the UltraLight's two-channel Camera ports have two ways to operate cameras. The first is for cameras with modified shutters. In most cameras today, the shutter switch is not a mechanical system, but instead is a switch that signals the microcontroller inside the camera to record an image. We can bypass the shutter switch in this kind of camera with two wires. The wires are connected to the Camera port so that the relay on board the UltraLight replaces the function of the shutter switch.

The same signal that operates a relay can also operate a Canon camera running CHDK and the remote USB shutter script. I haven't tested it yet; however, I suspect the UltraLight can operate both the relay and USB connections simultaneously. If so, the UltraLight can operate four cameras. (That is, if you don't mind them acting together in pairs.)

To take a picture, the PICAXE applies five volts to the relay or USB port for about one second to trigger the shutter. After waiting one second, the shutter is released so the camera is ready to take the next picture. The code to do just that is shown below:

```
Camera:
  high 4
  pause 1000
  low 4
return
```

### Antenna Port

At the bottom of the UltraLight is an SMA connector. This is the output for the two meter transmitter used to send position reports to chase crews on the ground. In a later article, I'll describe an antenna (and a camera rotator)

that works well with the UltraLight.

### Commit Pin

The last input to the UltraLight is the Commit pin. The Commit pin was built into the UltraLight because GPS receivers require time to get their satellite lock. So, rather than have the UltraLight record data while the near spacecraft is on the ground waiting for the GPS to catch up, the Commit pin inhibits the UltraLight from operating in flight mode. This doesn't mean the UltraLight can't operate experiments on the ground, however. It just means the UltraLight only performs actions on the ground that you desire. If you're like me, you don't want the camera taking lots of pictures of the launch crew filling the weather balloon – you want to save the SD card for pictures in flight.

The UltraLight Commit pin can be used in at least two ways. To start with, it can signal the UltraLight to download mission data when it is first powered up. Doing so permits recovery crews to download flight data in the field without having to reprogram the UltraLight. If the Commit pin is missing when the UltraLight starts up, then the PICAXE assumes the mission has been completed and the data is ready to be downloaded. Use this code to signal the UltraLight to download data:

```
if pin6 = 1 then Download
```

To use the Commit pin to inhibit data collection until closer to launch, use this code:

```
Wait_to_Commit:
  if pin6 = 0 then
  Wait_to_Commit
  ' wait for commit pin to be
  pulled
```

If this code occurs *after* the download detection, then the Commit pin does double-duty of downloading data and starting data logging.

### THAT'S A WRAP

That completes the UltraLight flight computer. You now have all the information needed to construct and program your own. As I've

mentioned before, *Nuts & Volts* readers are allowed to make their own UltraLight computer. I just ask that no one make copies to sell. Let me know how your project goes and I'll be happy to help readers get their own flight computer up and running.

For those who are interested in near space exploration but can't make their own printed circuit boards, NearSys LLC ([nearsys.com/catalog](http://nearsys.com/catalog)) produces a complete UltraLight kit.

Onwards and Upwards,  
Your near space guide **NV**

# \$51<sup>For 3</sup> PCBs

## FREE Layout Software!

## FREE Schematic Software!



01 DOWNLOAD our free CAD software

02 DESIGN your two or four layer PC board

03 SEND us your design with just a click

04 RECEIVE top quality boards in just days

# expresspcb.com

A kit for these experiments can be purchased from the *Nuts & Volts* Webstore at [www.nutsvolts.com](http://www.nutsvolts.com) or call us at 800-783-4624.

This circuit lets you adjust it to keep time to music, just like you would do with a standard mechanical metronome.

### 1. Build the Circuit.

Using the schematic along with the pictorial diagram, place the components on a solderless breadboard as shown. Verify that your wiring is correct.

### 2. Do the Experiment.

**Theory:** This is a two-transistor oscillator set up to make a tick-tick sound in the speaker. The potentiometer adjusts the bias on transistor Q1; this controls the speed of the turning on and off of transistors Q1 and Q2. The full musical tempo range should be attainable by adjusting the potentiometer from one extreme to the other.

**Procedure:** Connect a nine-volt battery to the battery snap. You should hear a tick-tick sound in the speaker. If you only hear one tick from the speaker, twist the potentiometer shaft from one extreme to the other until you hear the tick-tick sound. The speed of the ticks can be adjusted using the 100K potentiometer.

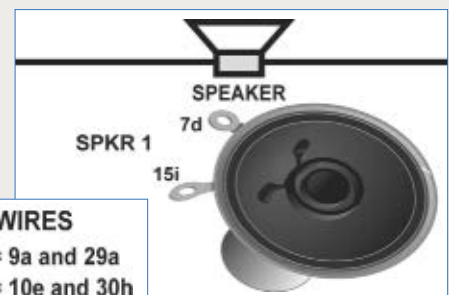
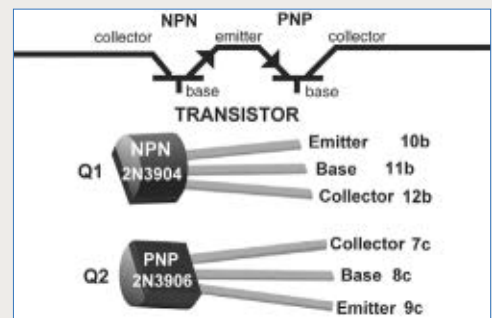
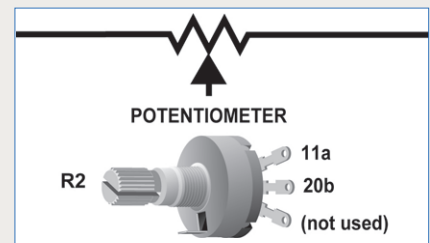
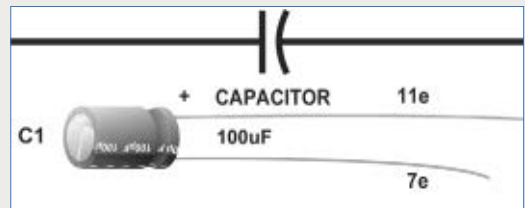
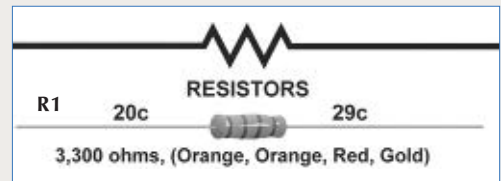
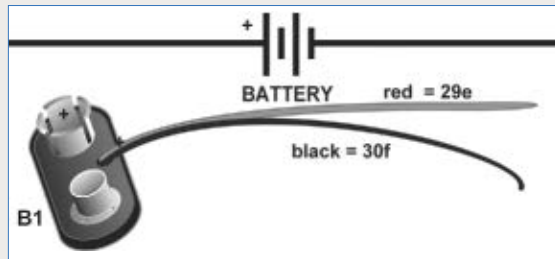
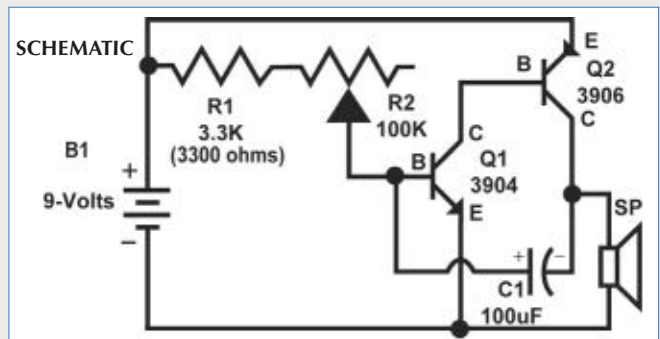

- WIRES**
- W1 = 9a and 29a
  - W2 = 10e and 30h
  - W3 = 15j and 30j
  - W4 = 12e and 8e

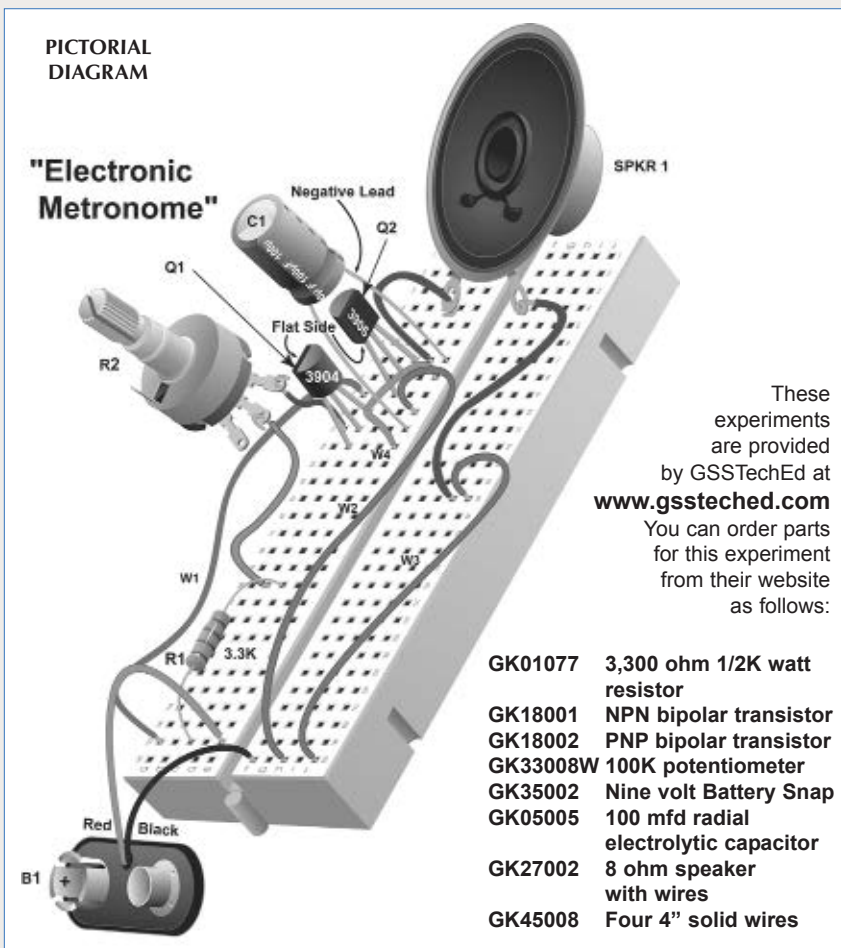

These experiments are provided by GSSTechEd at [www.gssteched.com](http://www.gssteched.com). You can order parts for this experiment from their website as follows:

- GK01077 3,300 ohm 1/2K watt resistor
- GK18001 NPN bipolar transistor
- GK18002 PNP bipolar transistor
- GK33008W 100K potentiometer
- GK35002 Nine volt Battery Snap
- GK05005 100 mfd radial electrolytic capacitor
- GK27002 8 ohm speaker with wires
- GK45008 Four 4" solid wires



## KIT OF THE MONTH

### 12/24VDC 20A Motor Speed Controller Kit KC-5502 \$29.00 plus postage & packing

Control the speed of 12 or 24VDC motors from zero to full power, up to 20A. Features optional soft start, adjustable pulse frequency to reduce motor noise, and low battery protection. The speed is set using the onboard trimpot, or by using an external potentiometer (available separately, use RP-3510 \$2.00).

NEW 2011

- Kit supplied with PCB and all onboard electronic components
- Suitable enclosure UB3 case, HB-6013 \$2.50

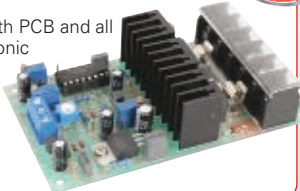

## SECURITY KITS

### UHF Rolling Code Remote Switch Kit KC-5483 \$72.00 plus postage & packing

High-security 3-channel remote control that can be used for keyless entry into residential or commercial premises or for controlling garage doors and lights. Features rolling code/code hopping, the access codes can't be intercepted and decoded by undesirables. The transmitter kit includes a three button key fob case and runs on a 12V remote control battery. The receiver is a short-form kit without case so you can mount it in the location or enclosure of your choice.

- Receiver 12VDC @ 150mA (1A for door strike use)
- PCB: Transmitter: 34 x 56mm
- Receiver: 110 x 141mm

Also available to suit: Additional Transmitter Kit KC-5484 \$29.00

Don't just sit there BUILD SOMETHING!

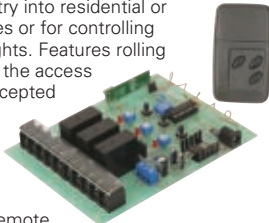

### Rolling Code Infrared Keyless Entry System KC-5458 \$47.00 plus postage & packing

This keyless entry system features two independent door strike outputs and will recognise up to 16 separate key fobs. The system keeps the coded key fobs synchronised to the receiver and compensates for random button presses while the fobs are out of range. Supplied with solder masked and silk screen printed PCB, two programmed micros, battery and all electronic components.

- Receiver requires a 12VDC 1.5A power supply
- Some SMD soldering is required
- PCB: 61 x 122mm



## Speedo Corrector MkII Kit

### KC-5435 \$39.75 plus postage & packing

When you modify your gearbox, diff ratio or change to a large circumference tyre, it may result in an inaccurate speedometer. This kit alters the speedometer signal up or down from 0% to 99% of the original signal. With this improved model, the input setup selection can be automatically selected and it also features an LED indicator to show when the input signal is being received. Kit supplied with PCB with overlay and all electronic components.

- PCB: 105 x 61mm
- Recommended box UB5 use HB-6013 \$2.50



## Universal Voltage Switch

### KC-5377 \$23.75 plus postage & packing

This is a universal module which can be adapted to suit a range of different applications. It will trip a relay when a preset voltage is reached. It can be configured to trip with a rising or falling voltage, so it is suitable for a wide variety of voltage outputting devices. For example a car throttle position sensor, air flow sensor, EGO sensor. You could even use it to trigger an extra fuel pump under high boost, anti-lag wastegate shutoff, and much more. Kit supplied with PCB, and all electronic components.

- PCB: 105 x 60mm



## Universal Power Supply Regulator

### KC-5501 \$11.00 plus postage & packing

This is an upgraded version of the original universal power supply kit published in August 1988. One small board and a handful of parts will allow you to create either a regulated  $\pm 15V$  rail or +15VDC single voltage from a single winding or centre tap transformer (not included). See website for more details.

- Includes all PCB and components for board, transformer not included
- PCB: 72(L) x 30(W)mm



## Ultrasonic Antifouling for Boats

### KC-5498 \$179.50 plus postage & packing

Marine growth electronic antifouling systems can cost thousands. This project uses the same ultrasonic waveforms and virtually identical ultrasonic transducers mounted in sturdy polyurethane housings. By building yourself (which includes some potting) you save a fortune! Standard unit consists of control electronic kit and case, ultrasonic transducer, potting and gluing components and housings. The single transducer design of this kit is suitable for boats up to 10m (32ft); boats longer than about 14m will need two transducers and drivers. Basically all parts supplied in the project kit including wiring. (Price includes epoxies).

- 12VDC
- Suitable for power or sail
- Could be powered by a solar panel/wind generator
- PCB: 78 x 104mm



Hundreds Sold!

## "Minivox" Voice Operated Relay

### KC-5172 \$11.50 plus postage & packing

Voice operated relays are used for 'hands free' radio communications and some PA applications etc. Instead of pushing a button, this device is activated by the sound of a voice. This tiny kit fits in the tightest spaces and has almost no turn-on delay. 12VDC @ 35mA required. Kit is supplied with PCB electret mic, and all specified components.

- PCB: 47 x 44mm



An excellent way for new comers to dip their toes into the wonders of electronics!

## SHORT CIRCUITS - VOLUME 1

This volume will teach you everything you need to get started in electronics and is suitable for ages 8+. We give you the option of buying the book on its own, or together with the accompanying kit that contains the components for each of the 20-odd projects described in the book. Some of the exciting projects include a Police Siren, Electronic Organ, Sound Effects Unit, Light Chaser and many, many more! The full colour 96 page book, is lavishly illustrated with over 100 drawings and diagrams. No prior knowledge of electronics is needed, projects are fun and totally safe to build.

**Short Circuits Book**  
BJ-8502 \$7.25

**Short Circuits Project Kit**  
KJ-8504 \$24.50

**Short Circuits Book and Project Kit**  
KJ-8502 \$32.50



MORE INFO AVAILABLE ONLINE

AGES 8+



## Post & Packing Charges

Order Value	Cost
\$25 - \$49.99	\$7.50
\$50 - \$99.99	\$20
\$100 - \$199.99	\$40
\$200 - \$499.99	\$60
\$500+	\$75

Max weight 12lb (5kg).  
Heavier parcels POA.  
Minimum order \$25.

## HOW TO ORDER

WEBSITE: [www.jaycar.com](http://www.jaycar.com)  
PHONE: 1-800-784-0263\*  
FAX: +61 2 8832 3118\*  
EMAIL: [techstore@jaycar.com](mailto:techstore@jaycar.com)  
POST: P.O. Box 107, Rydalmere NSW 2116 Australia  
• ALL PRICING IN US DOLLARS • MINIMUM ORDER ONLY \$25

\*Australian Eastern Standard Time  
(Monday - Friday 09.00 to 17.30 GMT + 10 hours)  
Note: 10-14 days for air parcel delivery

Note: Products are dispatched from Australia, so local customs duty & taxes may apply.  
Prices valid until 30/9/2011

Order online: [www.jaycar.com](http://www.jaycar.com)



# #38 SMILEY'S WORKSHOP

C PROGRAMMING - HARDWARE - PROJECTS

by Joe Pardue

## avrtoolbox and C Standard Library

Follow along with this series! Joe's book & kits are available at [www.nutsvolts.com](http://www.nutsvolts.com)

### Recap

This Workshop marks a milestone in the development of the avrtoolbox. It is the end of the beginning. We have discussed some useful software engineering concepts and applied them to processes for an Open Source project (<http://code.google.com/p/avrtoolbox>). We have applied these processes to the development of the libraries in libavr. Now, we will finish this beginning by learning about the venerable C standard library. We will look in detail at one of the venerable functions from that library: printf() (as it has been tweaked by avrlibc to work on the AVR); and we will look at some other standard functions that we'll apply to writing a simple command line interpreter. Our demonstration program will prove very useful for our future software development and testing.

### The C Standard Library

The C standard library isn't actually a library, but is the standard for an interface specification that library writers must use to write C runtime libraries that conform to the ISO C standard library specification. (There are other slightly different standards from other organizations.) These specifications are much like the functional requirements specifications that we discussed in the June '11 Workshop. Even though it is a specification and not a library, in general use when you see C standard library or C library, folks are talking about a specific software implementation. In our case, most of this is available in avrlibc ([www.nongnu.org/avr-libc](http://www.nongnu.org/avr-libc)).

If you read a lot about generic C and the standard library, you may be somewhat confused when you try to use these standard functions with microcontrollers. This will be especially true if you come from a background of using C with PCs. The reason for this confusion is that C was written for a computer with lots of RAM that held both the program and the data. However, RAM is expensive compared to ROM, so for microcontrollers — that must be as cheap as possible — the use of RAM is minimized and is only used for data while the program

resides in a separate part of memory (Flash EEPROM in the case of the AVRs; see the Workshops from June through October '10 for a detailed discussion).

Since C was written for systems with lots of RAM, many of the original library functions weren't written with the idea of husbanding scarce RAM resources. However, the avrlibc does a great job of providing special versions of the standard library functions that are optimized for limited memory use. Be aware that there are some C functions that even though they are available, you should avoid them and use simpler custom alternatives. For instance, I never use malloc() to allocate memory on the stack (which uses the RAM). It is available and I'd use it without a second thought on a PC (or even one of the larger AVRs like the ATmega256 with 8K RAM, but not AVRs like the ATmega48 with 512 bytes of RAM). For micros, RAM hungry functions like malloc are known to get folks in trouble, so I avoid them.

I also avoid some functions that use a lot of program memory like any functions that require floating point numbers. For instance, the standard I/O function printf() can take formatted floating point data types, but this inflates the code by a couple of thousand bytes. Even though that is in the cheaper program memory, I prefer to use alternatives to floating point wherever possible. The avrlibc manual discussion on printf() and the many ways they get around the floating point problems is very long and dense, so I'll try to simplify this later when we go into the details of our libavr implementation of printf() that builds on avrlibc.

Finally, there are a bunch of standard input functions based around scanf() that we will shun like the plague that it is — just take my word for it.

There are a bunch of sub-libraries declared in header files in the C standard library: <assert.h>, <complex.h>, <ctype.h>, <errno.h>, <fcntl.h>, <float.h>, <inttypes.h>, <iso646.h>, <limits.h>, <locale.h>, <math.h>, <setjmp.h>, <signal.h>, <stdarg.h>, <stdbool.h>, <stddef.h>, <stdint.h>, <stdio.h>, <stdlib.h>, <string.h>, <tgmath.h>, <time.h>, <wchar.h>, and <wctype.h>. Note that one of these is <stdlib.h> that is confusingly called the C standard library (but actually, it is but one of many).

One of the jobs we often have when writing C

programs is getting input from users and providing feedback to them. In typical simple embedded systems, this often involves buttons and LEDs. More complex systems may have keypads and LCDs. For our purposes — which are primarily educational — we assume that since the user will have a PC to use for development and uploading code, that we can also use that PC for communicating with the embedded system user via a terminal program, allowing us to use the PC keyboard and screen for input and output. This gives us the luxury (burden?) of using actual human readable sentences.

For example, we might want to have a standard sentence with a variable in it such as “The temperature is X degrees Fahrenheit” where X is a variable for the temperature. We want to have a way of reading a temperature with our microcontroller, then putting that value in X before sending it back to the user to read on a PC terminal: “The temperature is 70 degrees Fahrenheit.” As a preview, we would do this using the `stdio.h` library function: `printf(“The temperature is %d degrees Fahrenheit.”,temperature_variable)` — where the ‘%d’ tells the `printf()` function to write the value from `temperature_variable`.

Before we implement our version of the `stdio.h` function `printf()`, let’s take a look at `stdlib.h` to get an idea of what these libraries really are and how they are written.

## Using `stdlib.h`

You can probably visualize lots of situations like the one above where you might want to use stock constant text phrases mixed with variable data. The `stdlib.h` has some functions that will help. Let’s look at a few and see how they are implemented.

## A Few Practical Examples: `strlen`, `atoi`, `itoa`, and `reverse`

Since folks who either didn’t like to type or more likely were short on memory wrote these functions, the names are a bit more cryptic than those we use for our `avrtoolbox` functions — `strlen` is used to get the ‘string length,’ `atoi` is used to convert ‘ASCII to integer,’ `itoa` is used to convert ‘integer to ASCII,’ and `reverse` (which has a readable name) is used to reverse the order of characters in a string, which might sound like an odd thing to do. However, as we’ll see in a moment, it is quite useful.

Let’s write them ourselves (with some help from K&R):

```
int strlen(char s[])
{
    int i;
    i = 0;
    while(s[i] != '\0') ++i;
    return i;
}
```

In `strlen`, we accept a pointer to a string which is an array of characters with a terminal character ‘\0’. The `while` statement evaluates each character, incrementing

the index, `i`, until the terminal character is found. The return value is the number of characters, not including the terminal character. Well, that wasn’t rocket science, was it? It is a simple solution to a simple problem, but some of these functions are very clever, such as `atoi`.

Before you look at the `atoi` function, take out your paper and pencil computer and come up with an algorithm for converting an ASCII character string of numerals into an integer. For example, convert the string of char data types “1234\0” to the integer 1234. Give this some thought and see what you come up with. I’m serious now. Do it or the rest of the ink in the article will fade away and you’ll have an expensive drawing pad. Need a hint? Look at [www.asciitable.com](http://www.asciitable.com) and note that the characters for 1, 2, 3, and 4 are sequential integer numerals 0x31, 0x32, 0x33, and 0x34.

```
//NOTE: “borrowed” from K&R p. 43 atoi function
int atoi(char s[])
{
    int i, n;

    n = 0;
    for(i = 0; s[i] >= '0' && s[i] <= '9';
    ++i)
        n = 10 * n + (s[i] - '0');
    return n;
}
```

The `atoi` — ASCII to integer — function converts a string of ASCII characters representing the integers 0 through 9 into an integer number equivalent to the string. If you didn’t figure this one out yourself, then use your paper and pencil computer to run the function with `char s[]` equaling “1,2,3,4,\0” to see how it works. Note the condition in the `for` statement will cause the loop to bail if one of the characters is not equal to or between the characters 0 and 9. This gets us out of the loop, but not out of trouble. In a robust function, we would have some kind of error reporting mechanism so that code calling `atoi` could know that it sent a bad string, and so the calling function could build in some way to recover. We’ll get into all that some other time and be careful not to make mistakes now. (Famous last words.)

The conversion algorithm relies on the convenient fact that the ASCII characters for integers are represented by a sequence of numbers. ‘0’ is 0x30 in ASCII; ‘1’ is 0x31; and so on. So, if `s[i] = ‘1’` (the character), we get `(s[i] - ‘0’) = 1` (the integer). That is, we subtract the character 0, which has a value of 0x30 from the character 1 which has a value of 0x31, leaving us with the number 1. Voilà: ASCII to integer.

We start with `n = 0`, so the first time through the `10*n = 0` and the character are converted to the 1’s position in the integer. For each subsequent pass, the `n` has a value so we multiply it by 10, providing the 10’s, 100’s, and so forth.

You were asked to think about this algorithm before looking at the `atoi` function. Don’t be concerned if yours wasn’t as simple and elegant as this one. Mine wasn’t. It takes a while to start thinking like a computer. (Then your brain turns to silicon and people avoid you.) Just be glad other clever folks have thought about this and are willing to give you a good solution.

Now, think about the problem of reversing the characters in an array. How would you do this? Try it on the pencil and paper computer, then look at the reverse function:

```
//NOTE: "borrowed" from K&R p. 62 reverse
function
// reverse: reverse a string s in place
void reverse(char s[])
{
    int c, i, j;
    for (i = 0, j = strlen(s)-1; i < j; i++,
j--) {
        c = s[i];
        s[i] = s[j];
        s[j] = c;
    }
}
```

This is pretty straightforward. Put the first char from the array in a box, then put the last character in the array in the position of the first character. Then, take the stored character and put it in the last position in the array. Move your index in one position on both ends and repeat. So what? Well, we will use this to convert an integer to an ASCII number. As before – given the hint that we will use the reverse function – see if you can figure out how to write this integer to the ASCII function. My concept worked, but wasn't even close in the quality of the actual function in K&R. Oh, well:

```
//NOTE: "borrowed" from K&R p. 64 itoa function
void itoa(int n, char s[])
{
    int i, sign;
    if ((sign = n) < 0) // record sign
        n = -n;
    make n positive
    i = 0;
    do { // generate digits in reverse
        order
            s[i++] = n % 10 + '0'; // get next
        digit
    } while ((n /= 10) > 0); // delete it
    if (sign < 0)
        s[i++] = '-';
    s[i] = '\0'; // add null terminator for
    string
        reverse(s);
}
```

In my attempt at this, I never thought to do it backwards then reverse the string. First, store the integer in the sign variable and we get the sign of the integer by using the if statement to see if the integer is less than 0. If so, we multiply it by -1 to make it positive. Then we use do while, because we want to have at least one digit. Now, get out your paper and pencil computer and run the number 1234 through the do while loop, since no amount of explaining will be as effective as running the numbers yourself. Don't be tempted to succumb to boredom and blow this off; you should be able to understand this at this point in your C education. And it will be on the test.

## Using printf()

If you are prone to insomnia and this article isn't yet a cure for you, then I suggest you look at the verbiage on printf() in the avrlibc manual. It is a lot to wade through,

but fortunately we'll make using printf() with the usart as simple as we can. In fact, we've already made it pretty simple back in Workshop 35 where we discussed some Arduino-like elementary functions and included the serial\_out function that was a sneaky wrapper for printf() that hides much of the complexity from the easily spooked novice programmer.

Our implementation of printf() is in the usart library we looked at last month, so in order to use it all we have to do is include the usart.h header and we are good to go. If you want to know what is going on under the hood, you can look at the usart source code in

<http://code.google.com/p/avrtoolbox>. Let's not forget that lecture above about floating point – don't try to use it with this version of printf. If you do, you'll just get a ? returned instead of the expected number.

The parameter list for printf() is a bit different from what we've seen before since the list is variable with the number of parameters dependent on the number of format conversions you are doing in the string in the first parameter. An example for using printf():

```
uint8_t my_day = 21;
uint8_t my_month[] = {'J', 'u', 'l', 'y', 0};
uint16_t my_year = 1980;

printf("Your date of birth is:\n Day %d \nMonth:
%s \nYear %d.", my_day, my_month, my_year);
```

which shows in the terminal as:

```
Your date of birth is:
Day 21
Month July
Year 1980
```

This example should give you a feel for what is going on. You write a sentence and insert format characters preceded by % that match the variable list that you want to have formatted to be output as text. (Note that if you want to output a percent sign in your text, you'll need to use "%%.")

## Storing Text in Program Memory Space

The one problem with using printf() is that the text is loaded into RAM. Remember that RAM is expensive so we don't want to use it unless it's necessary. In the case of constant text, it isn't necessary. We can use a special version of printf() that takes constant text from the cheaper Flash program memory space. This is taken care of for us with functions from avrlibc.

The following shows a string that is stored in RAM versus one that is stored in program memory. Note the addition of the \_P to printf and that the parameter list begins with PSTR with the string contained in the following parenthesis:

```
printf("printf()Hello, World! - from RAM\r");
printf_P(PSTR("printf()Hello, World! - from
program memory\r"));
```

You can also use `printf_P` with constant strings defined outside of functions, usually at the top of a module or in a header as follows:

```
// This is a program memory string defined
// outside any function
// Used for testing sending a program string in
// test 7 below
const char PGM_STR1[] PROGMEM = "This is a
program memory string defined outside any
function.\r";

printf_P(PGM_STR1);
```

Let's use some of these C standard library functions in a practical example.

## A Command-line Interpreter

We will use a few selected C standard library functions in our `command_line_demo` program (in the `trunk\avr_applications` directory from <http://code.google.com/p/avrtoolbox/>) to give you a better feel for using the standard libraries and to provide this great little tool for future software development. We start by defining a protocol for issuing commands to a microcontroller. In our case, we want to send a text name for the command followed by some data, and we want to be able to issue a sequence of commands in a script that will give the micro a whole list of things to do. Imagine, for instance, that you want to program a robot arm to go through a sequence of motions. You might want it to get a part and put it into a bin, so you might want it to go up 10, left 20, down 10, pick up 1, up 10, right 20, down 10, drop 1. This implies that you have six commands up, down, left, right, pick up, and drop. For each command, you have some data that tells it how much of the command to do.

Let's decide on a protocol that takes commands as comma-separated units with the text command first, a space, the data, and then a comma to separate command units. We will also decide to use the `!` character to tell the micro that the command sequence has ended and to start processing the script. For example: `COMMAND3 123,COMMAND4 321,COMMAND6 65535,HELP 123,!`

Some of the stuff in `command_line_demo.c` is fairly advanced, but I'm going to assume that you can do pretty much what I do and if something doesn't quite make sense, you'll use it anyway since it works. My intention here is to provide a template that can be easily modified for use in other programs.

In the demo, we have the command name and function name associated with each other in a constant data structure stored in program memory space. For example, the text `COMMAND0` is associated with the name of the function to call when you receive that text, `command0()`:

```
const CMDS COMMANDS[] PROGMEM = {
{"COMMAND0", command0},
{"COMMAND1", command1},
```

```
{ "COMMAND2", command2},
{"COMMAND3", command3},
{"COMMAND4", command4},
{"COMMAND5", command5},
{"COMMAND6", command6},
{"HELP", help},
{0, NULL}
}
```

In a real application, `COMMAND0` might be something like `goleft` and the associated function could be `my_go_left_func()`. These names are entirely arbitrary and should be whatever makes sense to you. In the demo case, we have six generic commands and a help command. At this point, you should mark this spot and go peruse the source code in `avrtoolbox` to get a feel for what it is doing. In order to make our command-line interpreter work, we use the C standard library functions that I've listed along with the line number for each in the source code:

**Line 99 uses `strchr` from `string.h`.** This function returns true if the string in the first parameter contains the character in the second parameter. In this case, the string is in the USART receive buffer and the character is defined by the constant `TERMINATOR` which, in our case, is `!`.

```
// Load until terminator received
if(strchr((const
char*)usart0_receive_buffer, TERMINATOR))
{
    parse_command();
    usart0_receive_buffer_clear();
}
```

**Line 168 uses `strcmp` from `string.h`.** This function compares two strings and – contrary to all logic – returns a 0 if they are the same. The reason for the 0 is arcane so just try to remember that in this case, false is true. Also note that the way we get the first string in the parameter list is even more arcane since it requires some serious twisting to get the string from program memory so that it can be compared to the second parameter in RAM. I won't pretend that I'll remember how to do this next time I need to do this, so I'll just look back and copy how it is done here:

```
if( !strcmp(
(char*)pgm_read_word(&COMMANDS[i].PTEXT), command)
)
{
    // Get the function and call it
    p_func =
(PGM_VOID_P)pgm_read_word(&COMMANDS[i].PFUNC);
    p_func(atoi(data));
    valid = true;
}
```

**Line 173 uses `atoi` from `stdlib.h`.** Notice that in the above code snippet, we are using the `atoi` function discussed above to convert the data from the ASCII to an integer that we are now sending to the command which is disguised as `'p_func.'` Yes indeed, this is getting dense. In Line 172, we turned the command function name from our `COMMANDS` structure into a pointer to the particular command function indicated,

and loaded it to `p_func`. If the function is named `my_func(uint16_t my_data)`, then we now have an alias to that function that feeds the results of the `atoi` function on the ASCII string data as the parameter for `my_func`. The line `p_func(atoi(data));` is the same as if you used `my_func(atoi(data));`.

**Line 204 uses `strcpy` from `string.h`.** Here we do something simple: We copy the receive buffer into another buffer that we will use to parse the command script. This solves the problem of what we would do if we were in the midst of parsing the receive buffer and received more data that might cause it to wrap around and trash some of the data. This also brings up an important safety tip: Don't send a script that is longer than the receive buffer!

```
strcpy((char *)buf, (char
*)usart0_receive_buffer);
```

**Line 212 uses `strlen` from `string.h`.** This tells us the length of the buffer so that we can run our for loop through it one character at a time.

```
for(i = 0; i < strlen((const char *)buf); i++)
```

**Line 230 uses `isalnum` from `ctype.h`.** Here, we test to see if the character in `temp_buf[j]` is alphanumeric which is what we have restricted our commands to use.

```
if(isalnum(temp_buf[j]))
```

**Line 249 uses `isdigit` from `ctype.h`.** In a similar vein, we check to make sure the data is all digits, so we can use `atoi` to convert it into an integer.

```
if(isdigit(temp_buf[j]))
```

Finally, `printf_P` from `stdio.h` is used all over the place.

These are just a few of the many useful (and sometimes bizarre) functions that you will find in the C standard library, so someday when you've got more time, do take a look at the `avrlibc` manual and see what else is available.

## Testing by Using Scripts in Developers Terminal

We will use my Developers Terminal to test the `command_line_demo` by sending it a script that follows our command protocol. Then we will use four additional scripts, each with a different sort of error to make sure the program works as required.

**Script 1 – Correct command.**

```
COMMAND3 123,COMMAND4 321,COMMAND6 65535,HELP 123,!
```

**Script 2 – Error: Non-alphanumeric character in command field.**

```
C@COMMAND3 123,COMMAND4 321,COMMAND6 65535,HELP 123,!
```

**Script 3 – Error: Non-digit in data field.**

```
COMMAND3 1A23,COMMAND4 321,COMMAND6 65535,HELP 123,!
```

**Script 4 – Error: No space between command and data fields.**

```
COMMAND3 123,COMMAND4321,COMMAND6 65535,HELP 123,!
```

**Script 5 – Error: No comma between two command units.**

```
COMMAND3 123 COMMAND4 321,COMMAND6 65535,HELP 123,!
```

**Script 6 – Error: No script terminating character.**

```
COMMAND3 123,COMMAND4 321,COMMAND6 65535,HELP 123,!
```

We will put these scripts into an XML file so that we can load them into Developers Terminal and send them with a single click with the Send Macro feature. You'll want to get the `XMLData.xml` file from the `avrtoolbox` command-line directory and put it in the directory with your Developers Terminal executable. If you don't yet have Developers Terminal, you can get it under the `avrtoolbox` `pc_applications` directory. Note that this Terminal is an outgrowth of the discussions in Workshops 18, 19, and 20, and the details are in my book *Virtual Serial Port Cookbook* that you can get along with the associated hardware projects kit from the *Nuts & Volts* Webstore at <http://nutsvolts.com>.

When you open your serial link to the command-line interpreter and reset the micro or type `HELP`, you'll see the output shown in **Figure 1**. This serves for now as a template for the real help that you'll want to show with your version of this software. When you apply this to a real program, you will likely want names more descriptive than `COMMAND0` followed by some text that says something more informative than "Brief description of the command."

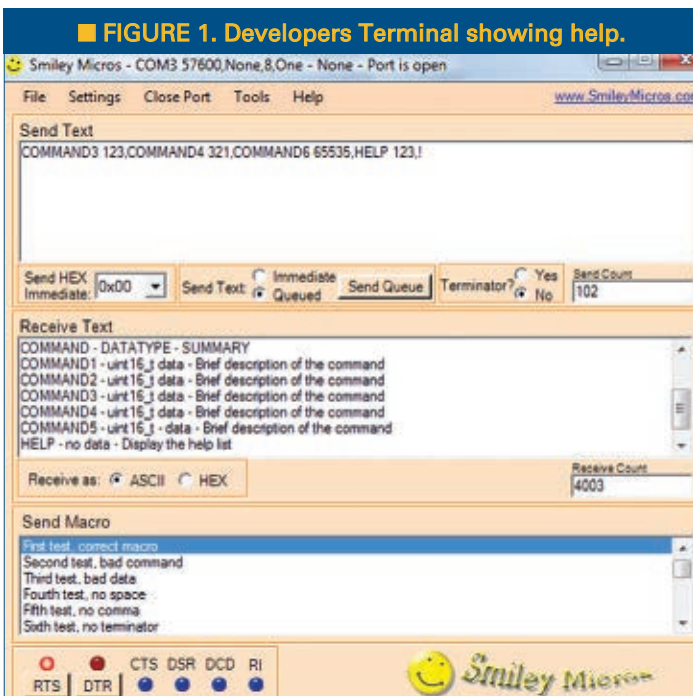

We test the code by intentionally sending scripts with errors. When we click on each error macro, we see the output shown in **Figure 2**. Note that the third line shows that the first command was handled correctly since it has no errors. Further note that the 'Sixth test, no terminator' macro results in nothing showing on the Receive Text box since the command\_line\_demo has no way of knowing that we think we have sent it a valid script. So, it sits spinning its wheels waiting for the TERMINATOR character (hint – it isn't a former governor of California). This is not a rigorous validation of the code. For one thing, it won't catch improper use of the SEPARATOR and TERMINATOR characters, but it is certainly good enough for now. If you find a problem, well, you've got the source code.

If we want to convert the demo to a real application like the robot pick and drop we mentioned above, we would modify the COMMANDS array as shown next:

```
const CMDS COMMANDS[] PROGMEM = {
  {"UP", move_up},
  {"DOWN", move_down},
  {"LEFT", move_left},
  {"RIGHT", move_right},
  {"PICKUP", close_gripper},
  {"DROP", open_gripper},
  {"HELP", help},
  {0, NULL}
}
```

We would write the indicated functions: `move_up()`, `move_down()`, `move_left()`, `move_right()`, `close_gripper()`, and `open_gripper()`. Now, all you have to do is call them with a command-line script. Simple, huh? Well, I think so, and you are going to see this thing a lot in the coming months where I'll use it for lots of software and hardware micro machinations.

Questions? As usual, if you want to be helpful when you find a problem or have a question, you'll need to put on your biohazard suit and start a thread on [www.avrfreaks.net](http://www.avrfreaks.net) with the word 'avrtoolbox' in the title. This way, I'll probably see it. (First, read my blog entry that will tell you why you need the biohazard suit: <http://smiley-micros.com/blog/2011/01/24/using-an-internet-forum>.)

Next month, I think we are going to take a look at digital input and output, so stay tuned and find out. If you just can't wait and want to get a leg up on all this serial stuff and real C programming for the AVR (while helping support your favorite magazine and technical writer), then

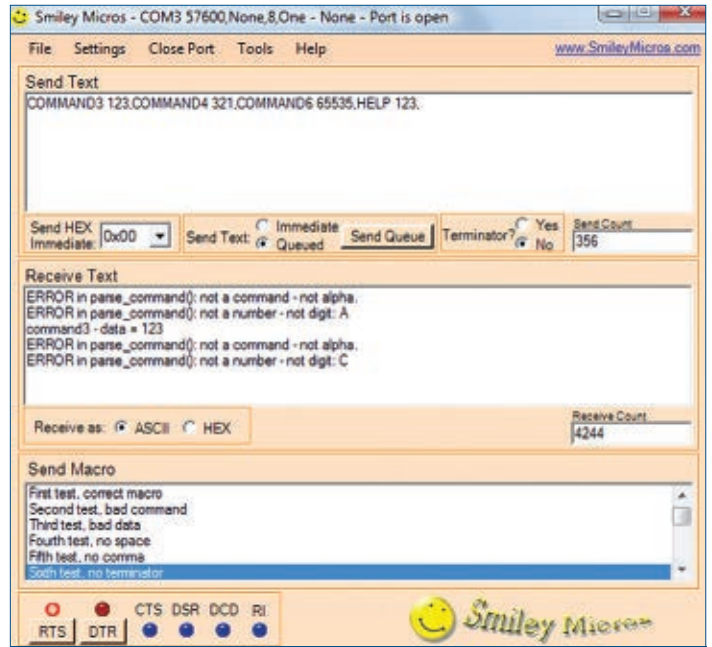

■ FIGURE 2. Catching script errors.

buy my *C Programming* book, Butterfly projects kit, and the *Virtual Serial Port Cookbook* from the *Nuts & Volts* shop mentioned previously. **NV**



**\$149.<sup>95</sup>**

USB-LOGIC  
**USB Logic Analyzer**

**New**



**\$99.<sup>95</sup>**

DSO-NANO-V2  
**Pocket-Sized Digital Oscilloscope**



**\$59.<sup>95</sup>**

ARDUINO-STK  
**Arduino Uno Starter Kit**



**\$59.<sup>95</sup>**  
ASSEMBLED

UK1104  
**4-Port USB Relay Controller with 6-Channel Analog/Digital Interface**

FM Transmitters • Timers • Audio Amplifiers • Motor Controllers • Custom Designs

**www.canakit.com**      **1-888-540-KITS (5487)**

# ELECTRONET

Now available in the Nuts & Volts webstore, the 16-Bit Experimenter Handbook CD-ROM.

By Tom Kibalo



200-Pages of detailed explanations.  
41 Fully illustrated experiments in 'C' code.

**\$69.95**  
Subscriber Discount Available!

For more information and kits, please visit:  
[www.nutsvolts.com](http://www.nutsvolts.com)

[www.canakit.com](http://www.canakit.com)

- Over 200 Kits & Modules to choose from!
- Easy Worldwide Online Ordering
- Fast Delivery & Same Day Shipping



FM Transmitters • Timers • Audio Amplifiers • Motor Controllers

**superbrightleds.com**

Component LEDs - LED Replacement Bulbs - LED Accent Lighting

Super Bright LEDs Inc. St. Louis, Missouri - USA [superbrightleds.com](http://superbrightleds.com)

**PAIA** [paia.com](http://paia.com) Music/Tutorials/Kits  
Analog Synthesizers  
Guitar Effects  
Tube Electronics  
Studio Gear

Electronic Music Kits and More

## Sheet Metal Fabrication



**Complete Fabrication Center**  
Integrated Ideas & Technologies, Inc.  
Precision Laser, Waterjet, Plasma, Machining,  
Forming, and Welding Capabilities  
[www.iitmetalfab.com](http://www.iitmetalfab.com)

**USB** Add USB to your next project—  
it's easier than you might think! **DLP Design**

- USB-FIFO • USB-UART • USB/Microcontroller boards
- RFID Reader/Writer • ZigBee Ready Transceivers

[www.dlpdesign.com](http://www.dlpdesign.com)  
*Absolutely NO driver software development required!*

Serial LCD & LED  
[www.melabs.com](http://www.melabs.com)

**Pololu**  
Robotics & Electronics  
[WWW.POLOLU.COM](http://WWW.POLOLU.COM)

THE ORIGINAL SINCE 1994  
**PCB-POOL**  
Beta LAYOUT

- Low Cost PCB prototypes
- Free laser SMT stencil with all Proto orders

[WWW.PCB-POOL.COM](http://WWW.PCB-POOL.COM)

**MINDS-i** What can YOU build?  
[mymindsi.com](http://mymindsi.com)

**ramsey**  
[www.ramseykits.com](http://www.ramseykits.com)  
AM/FM Broadcasters • Hobby Kits  
Learning Kits • Test Equipment  
...AND LOTS OF NEAT STUFF!

**INVEST in your BOT!**

INVEST in **HITEC**

12115 Paine Street • Poway, CA 92064 • 858-748-6948 • [www.hitecrcd.com](http://www.hitecrcd.com)

**ALL ELECTRONICS**  
CORPORATION  
Electronic Parts & Supplies  
Since 1967

For the ElectroNet online, go to  
[www.nutsvolts.com](http://www.nutsvolts.com)  
click **Electro-Net**



# The Nuts & Volts **WEBSTORE**

## ELECTRONICS

### 15 Dangerously Mad Projects for the Evil Genius

by Simon Monk

**NEW!**

UNLEASH YOUR INNER MAD SCIENTIST!

This wickedly inventive guide explains how to design and build 15 fiendishly fun electronics projects. Filled with photos and illustrations, *15 Dangerously Mad Projects for the Evil Genius* includes step-by-step directions, as well as a construction primer for those who are new to electronics projects.

**\$24.95**

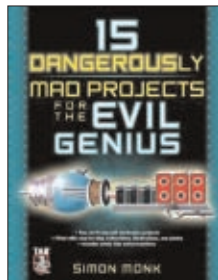

### Master and Command C for PIC MCUs

by Fred Eady

*Master and Command C for PIC MCU, Volume 1* aims to help readers get the most out of the Custom Computer Services (CCS) C compiler for PIC microcontrollers. The author describes some basic compiler operations that will help programmers — particularly those new to the craft — create solid code that lends itself to easy debugging and testing. As Eady notes in his preface, a single built-in CCS compiler call (output\_bit) can serve as a basic aid to let programmers know about the "health" of their PIC code.

**\$14.95**



### How to Diagnose and Fix Everything Electronic

by Michael Jay Geier

**Master the Art of Electronics Repair!**

In this hands-on guide, a lifelong electronics repair guru shares his tested techniques and invaluable insights.

*How to Diagnose and Fix Everything Electronic* shows you

how to repair and extend the life of all kinds of solid-state devices, from modern digital gadgetry to cherished analog products of yesteryear.

**About the Author**

Michael Jay Geier began operating a neighborhood electronics repair service at age eight that was profiled in *The Miami News*.

**\$24.95**



### tinyAVR Microcontroller Projects for the Evil Genius

by Dhananjay Gadre and Nehul Malhotra

Using easy-to-find components and equipment, this hands-on guide helps you build a solid foundation in electronics and embedded programming while accomplishing useful — and slightly twisted — projects. Most of the projects have fascinating visual appeal in the form of large LED-based displays, and others feature a voice playback mechanism. Full source code and circuit files for each project are available for download.

**\$24.95**



### Build Your Own Electronics Workshop

by Thomas Petruzzellis

**BUILD YOUR OWN DREAM ELECTRONICS LAB!**

This value-packed resource provides everything needed to put together a fully functioning home electronics workshop! From finding space to stocking it with components to putting the shop into action -- building, testing, and troubleshooting systems. This great book has it all! And the best part is, it shows you how to build many pieces of equipment yourself and save money, big time!

**Reg Price \$29.95**  
**Sale Price \$24.95**



### Electronics Explained

by Louis Frenzel

**The New Systems Approach to Learning Electronics**

Don't spend time reading about theory, components, and old ham radios - that's history! Industry veteran, Louis Frenzel, gives you the real scoop on electronic product fundamentals as they are today. Rather than tearing electronics apart and looking at every little piece, the author takes a systems-level view. For example, you will not learn how to make a circuit but how a signal flows from one integrated circuit (IC) to the next, and so on to the ultimate goal.

**\$29.95**

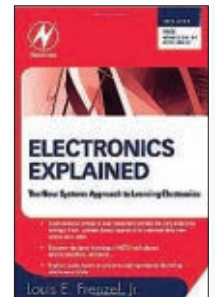

### Making Things Move: DIY Mechanisms for Inventors, Hobbyists, and Artists

by Dustyn Roberts

In *Making Things Move: DIY Mechanisms for Inventors, Hobbyists, and Artists*, you'll learn how to successfully build moving mechanisms through non-technical explanations, examples, and do-it-yourself projects — from kinetic art installations to creative toys to energy-harvesting devices. Photographs, illustrations, screenshots, and images of 3D models are included for each project.

**\$29.95**



### TEARDOWNS

by Bryan Bergeron

**Learn How Electronics Work by Taking Them Apart**

Amp up your knowledge of electronics by deconstructing common devices and analyzing the revealed components and circuitry. *Teardowns: Learn How Electronics Work by Taking Them Apart* contains 14 projects that expose the inner workings of household appliances, workbench measuring instruments, and musical equipment. Discover how resistors, capacitors, sensors, transducers, and transistors function in real circuitry.

**Reg \$24.95**    **Sale Price \$21.95**



### PICAXE Microcontroller Projects for the Evil Genius

by Ron Hackett

This wickedly inventive guide shows you how to program, build, and debug a variety of PICAXE microcontroller projects. *PICAXE Microcontroller Projects for the Evil Genius* gets you started with programming and I/O interfacing right away, and then shows you how to develop a master processor circuit.

**\$24.95**



Order online @ [www.nutsvolts.com](http://www.nutsvolts.com)  
 Or CALL 1-800-783-4624 today!

**BOOK & KIT COMBOS**

**Beginner's Guide Complete Combo!**

Combo Price **\$229.95**  
 VOL 3 Experiment Component Pack

For complete details, visit our webstore @ [www.nutsvolts.com](http://www.nutsvolts.com).

**16-Bit Complete Combo**

Combo Price **\$319.95**

For complete details visit our webstore @ [www.nutsvolts.com](http://www.nutsvolts.com)

**Puzzled by the Arduino?**

Based on *Nuts & Volts Smiley's Workshop*, this combo gives you all the pieces you need!

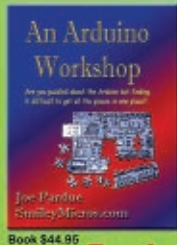

**Book and Kit Combo \$124.95**

**CD-ROM SPECIALS**

**Nuts & Volts  
 7 CD-ROMs  
 & Hat Special!**

That's 84 issues.  
 Complete with supporting code and media files.

Published monthly by T & L Publications, Inc. [www.nutsvolts.com](http://www.nutsvolts.com)

**Free Shipping!**

**Only \$149.95**  
 or \$24.95 each.

**The Learning Lab**



Reg Price \$79.95

Subscriber's Price \$75.95

This lab — from the good people at GSS Tech Ed — will show you 40 of the most simple and interesting experiments and lessons you have ever seen on a solderless circuit board. As you do each experiment, you learn how basic components work in a circuit. Along with the purchase of the lab, you will receive a special password to access the fantastic online interactive software to help you fully understand all the electronic principles. For a complete product description and sample software, please visit our webstore.



This great little book is a concise all-purpose reference featuring hundreds of tables, maps, formulas, constants, and conversions. AND it still fits in your shirt pocket!

**CALL 1-800-783-4624 today!**  
**Or Order online @ [www.nutsvolts.com](http://www.nutsvolts.com)**

**PROJECTS**

**32-Bit Micro Experimenter Board**

The new 32-Bit Micro Experimenter is the fastest way to learn 32-bit microcontrollers.



The kit includes onboard 46 programmable I/O and USB, free software, carefully documented step-by-step experiments for USB, embedded web server, graphics and audio, wireless, RTOS, and file I/O. User pushbuttons, LEDs, and 32 kHz clock crystal. Can be used in solderless breadboard environment or stand-alone.

Also supports Arduino compatible interface.

Subscriber's Price **\$89.95**  
 Non-Subscriber's Price **\$93.95**

**Piezoelectric Film Speaker Kit**

As seen in the November 2010 issue, here is a great project to amaze your friends and to demonstrate a unique way of producing sound. Kit contains one piece of piezoelectric film, speaker film stand, PCB, components, audio input cable, and construction manual. All you'll need to add is a battery and a sound source. For more info, please visit our website.

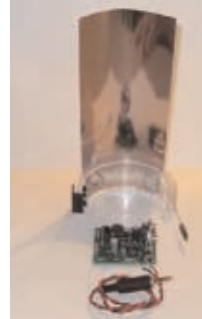

Subscriber's Price **\$69.95**  
 Non-Subscriber's Price **\$74.95**

**CHIPINO Kit**

The CHIPINO module is an electronic prototyping platform that is used in a series of articles starting with the March 2011 issue of *Nuts & Volts Magazine*.



**Assembled units \$29.95!**

Developed by the CHIPAXE Team as a bridge between PICs and Arduinos. The module was designed specifically to match the board outline, mounting holes, connector spacing, and most of the microcontroller I/O functions found on the popular Arduino module.

Subscriber's Price **\$18.95**  
 Non-Subscriber's Price **\$19.95**

**Magic Box Kit**

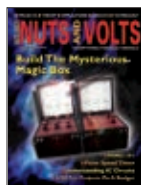

As seen on the April 2007 cover

This unique DIY construction project blends electronics technology with carefully planned handcraftsmanship. This clever trick has the observer remove one of six pawns while you are out of the room and upon re-entering you indicate the missing pawn without ever opening the box.

Includes an article reprint.

Subscriber's Price **\$39.95**  
 Non-Subscriber's Price **\$45.95**

**Mini-Bench Supply Complete Kit**



A small power supply with +5V, +12V, and -12V outputs is a handy thing to have around when you're breadboarding circuits with both op-amps and digital ICs.

Kit includes: Enclosure box, accessories, DC-to-DC converter kit, switching regulator kit, and article reprint. For more information, please see the "feature article section" on the of the *Nuts & Volts* website.

Subscriber's Price **\$76.95**  
 Non-Subscriber's Price **\$83.95**

**Sorting Counter Kit NEW!**



As seen in the July 2011 issue.



Sorting counters have many uses — keeping score, counting parts, counting people — it is just a handy gadget to have around. This is a very simple project for those who want to learn to solder or are interested in using microprocessors and how they function. No special tools are needed, just a small tip soldering iron. It has no box as it stands alone, therefore there is no drilling.

Subscriber's Price **\$33.95**  
 Non-Subscriber's Price **\$39.95**

**16-Bit Experimenter Handbook**



**NEW!**

From the series of articles by Tom Kibalo, *The Complete 16-Bit Experimenter Handbook on CD-ROM!*

This CD-ROM handbook contains: 200 pages of detailed instructions and 41 experiments with 'C' software examples. Also includes the experiments for the dsPIC33.

For a complete list of kits and combos, please visit our webstore.

Subscriber's Price **\$64.95**  
 Non-Subscriber's Price **\$69.95**

**Transistor Clock Kit**

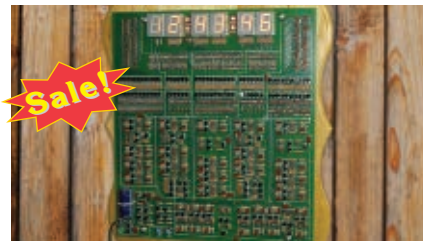

**Sale!**

If you like electronic puzzles, then this kit is for you! There are no integrated circuits; all functionality is achieved using discrete transistor-diode logic. The PCB is 10"x11" and harbors more than 1,250 components! For more info, see the November 2009 issue.

Reg **\$225.95**  
**Sale Price \$199.95**

PCBs can be bought separately.

**The Amateur Scientist 4.0 The Complete Collection**

by Bright Science, LLC

There are 1,000 projects on this CD, not to mention the additional technical info and bonus features. It doesn't matter if you're a complete novice looking to do their first science fair project or a super tech-head gadget freak; there are enough projects on the single CD-ROM to keep you and 50 of your friends busy for a lifetime!

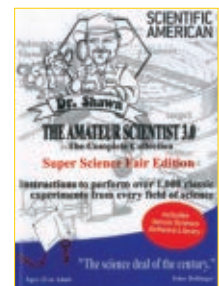

Reg **\$26.95** **Sale Price \$23.95**

■ BY FRED EADY

## SLAVING AWAY FROM USB HOST

Many of today's USB devices began life as RS-232 serial devices. Thanks to FTDI, one of the easiest ways to convert a legacy RS-232 device to a USB device is to replace the RS-232 circuitry with an FTDI USB-to-UART bridge IC. One immediate drawback of converting to USB is that the open nature of the RS-232 device to microcontrollers is lost. In the majority of cases, a USB slave device will require the services of a USB host device in the form of a personal computer.

Today, microcontrollers that were once restricted to the USB slave role can assume the responsibilities of a USB host device. In this edition of Design Cycle, we're going to host a USB device that was intended to interface to a PC USB portal with a USB-enabled microcontroller.

### VINCO 101

The Arduino-styled Vinco shown in **Photo 1** is FTDI's latest Vinculum-II development platform. The Vinco can be programmed with the new Vinco API libraries or with the traditional Vinculum-II API tool set. Note that the Vinco takes on that classic Arduino shape. That's no happenstance as the Vinco mechanical pinout is design to support Arduino shields. The idea is to port the shield hardware and application to run under the control of a Vinculum-II. To ease the porting process, the FTDI folks provide the Vinculum-II IDE, the Vinculum-II compiler, and a multitude of FTDI utilities and drivers at no cost.

The Vinco's Mini-B USB connector is normally used as a USB slave portal, while the larger Type A connector

supports host-mode applications. The Vinco is built around the 64-pin Vinculum-II programmable host controller. The only supporting IC is a Microchip MCP3008 10-bit analog-to-digital converter which is accessed via a Vinculum-II SPI portal. All of the other Vinco circuitry is dedicated to power supply duty, I/O interfacing, and a programming/debugging portal. There is no onboard programming circuitry. Thus, the Vinco requires a VNC2 debugger/programmer module like the one you see in **Photo 2**. **Schematic 1** is a graphical overview of the Vinco's Vinculum-II core.

Look back at **Photo 1** and locate the LEDs that are positioned on either side of the Type A USB connector. The pair of LEDs lies just to the right of the silkscreen labels USB1 and USB2. Once you've located the LEDs in **Photo 1**, note their electrical attachment in **Schematic 1**. According to **Schematic 1**, all we have to do is drop their cathodes to a logically low level to illuminate them, right? Well, there are a couple of ways to do that. Here's the Vinco API way:

```
pinMode(39,OUTPUT); //make pin 39 an output pin
digitalWrite(39,LOW); //write a logical LOW to
//pin 39
```



Trouble is, the Vinco API way won't work. Pin 39 is not defined in the Vinco GPIO (General-Purpose I/O) libraries and neither is pin 40 which drives LED2. However, there are 30 I/O pins and eight analog pins that are defined in the Vinco API.

No worries with the absence of pins 39 and 40 definitions in the Vinco API. We can always fall back on the Vinculum-II API. The first order of business is to configure the Vinculum-II's I/O multiplexer:

```
// Configure IOMUX
// GPIO Port A 0 to pin 39 as Output.
vos_iomux_define_output(39,
IOMUX_OUT_GPIO_PORT_A_0); // LED1#
// GPIO Port A 1 to pin 40 as Output.
```

■ **PHOTO 1.** For beginners, the Vinco can be programmed using an Arduino-like API library. In that the Vinco is based on the Vinculum-II, the advanced programmer can also apply the standard Vinculum-II API calls to a Vinco application.

■ PHOTO 2. An FT232RL and a HVC241 gate IC are mounted on the other side. We built a garage-brewed version of this debugger/programmer in the September '10 edition of Design Cycle.

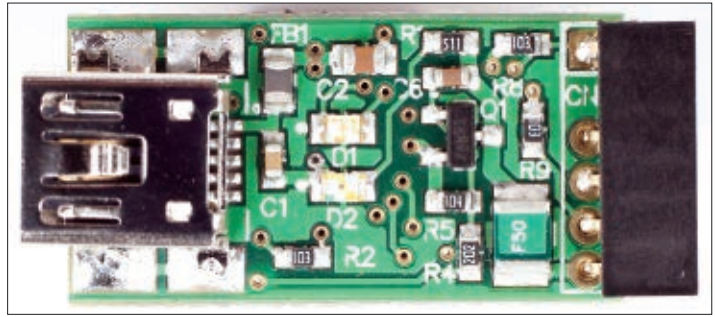

```
vos_iomux_define_output(40,
IOMUX_OUT_GPIO_PORT_A_1); // LED2#
// GPIO Port A 2 to pin 41 as Output.
```

The IOMUX configuration code can be manually created or we can go the easy way and have the Vinculum-II IDE's VNC2 IOMux config utility generate the code for us. The config utility is part of the Vinculum-II IDE and is easy to use. So, with the help of the utility, I've selected and configured the Vinculum-II's pin 39 in **Screenshot 1**. The same procedure was performed for pin 40. Note that in the pin 40 configuration I chose to use the next available PORT A I/O position (A1). The Vinculum-II architecture requires us to create an instance of the GPIO context, whose template – *gpio\_context\_t* – is located in the API file *GPIO.h*. The context template is a simple structure that is commonly used in C programming:

```
// GPIO context
typedef struct _gpio_context_t {
```

```
    unsigned char port_identifier;
} gpio_context_t;
```

We'll call our newly created instance of the GPIO context *gpioCtxA*. Again, we'll use standard C methods to instantiate the new context:

```
gpio_context_t gpioCtxA;
```

Now that we have generated a unique context for our IOMUX definitions, we need to associate our PORTA I/O definitions with the Vinculum-II's physical PORTA device

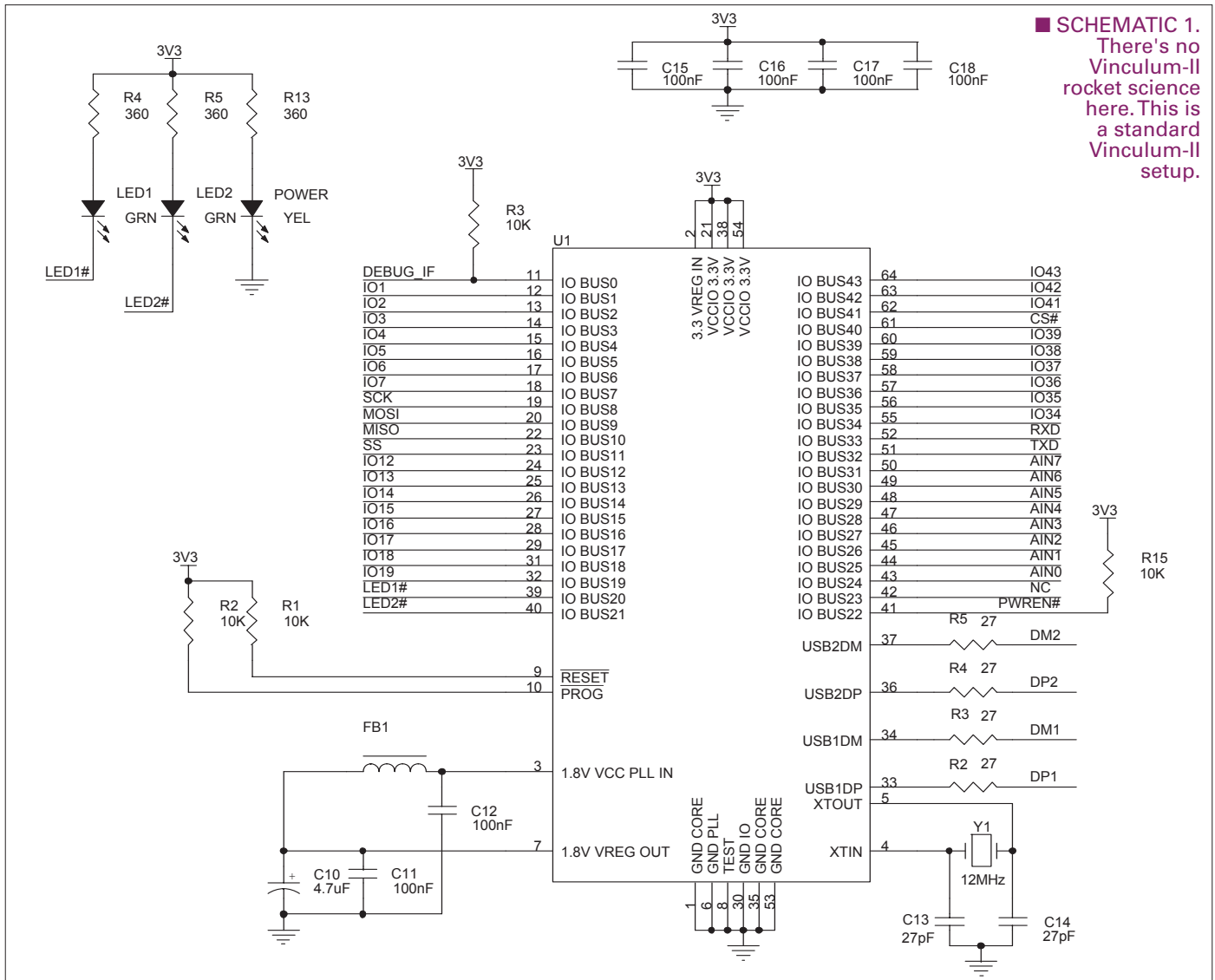

■ SCHEMATIC 1. There's no Vinculum-II rocket science here. This is a standard Vinculum-II setup.

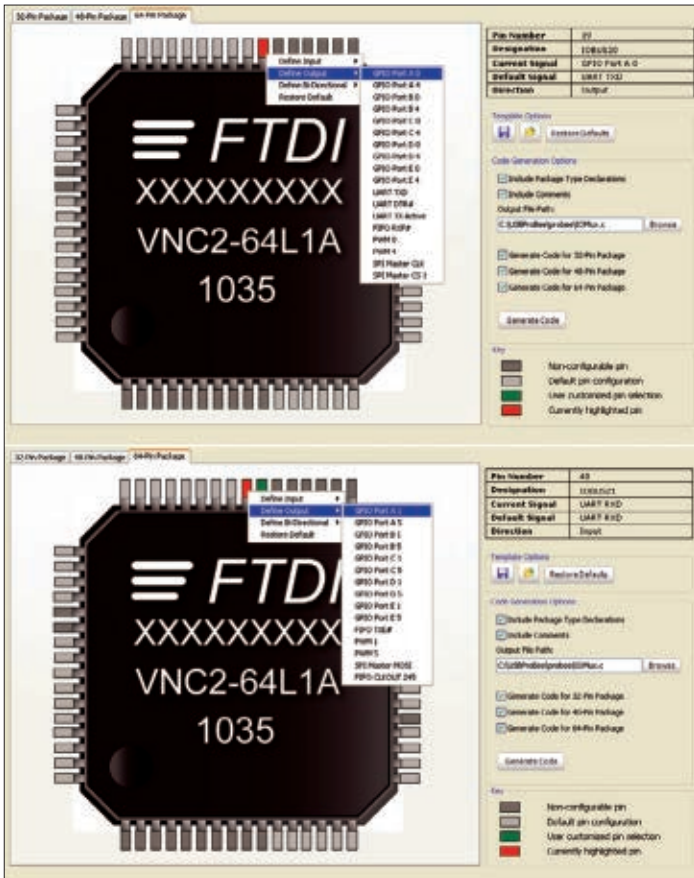

■ **SCREENSHOT 1.** Setting up the Vinculum-II's I/O subsystem is as easy as pointing and clicking. Note that we could have assigned pins 39 and 40 to any of the Vinculum-II's GPIO ports and a select list of peripheral devices.

(GPIO\_PORT\_A). We do that by filling in our *gpioCtxA* context's *port\_identifier* variable with the Vinculum-II GPIO port we wish to associate with our GPIO code. In that we defined the LED I/O pins as belonging to Vinculum-II's GPIO\_PORT\_A, our *gpioCtxA* *port\_identifier* entry looks like this:

```
// initialize device driver
gpioCtxA.port_identifier = GPIO_PORT_A;
```

In the Vinculum-II programming world, control blocks are used to hold command codes, variables, and identifiers that are used by VOS (Vinculum Operating System) commands. With that thought in mind, let's create yet another structure instance based on this IOCTL (I/O Control) template found in *GPIO.h*:

```
// GPIO control block for use with GPIO
//IOCTL function
typedef struct _gpio_ioctl_cb_t {
    unsigned char ioctl_code;
    unsigned char value;
} gpio_ioctl_cb_t;
```

In traditional C manner, we'll create an instance of the structure *gpio\_ioctl\_cb\_t* called *gpio\_iocbA*:

```
//spawn an I/O control block called gpio_iocbA
gpio_ioctl_cb_t gpio_iocbA;
```

Our new *gpio\_iocbA* structure will allow us to initiate VOS GPIO commands. However, we have one more GPIO task to complete before we can issue commands via our brand new *gpio\_iocbA* structure. We need to open the GPIOA I/O port which is viewed as a device by the Vinculum-II:

```
/**
 * VOS DEVICES
 */
#define VOS_NUMBER_DEVICES 4
#define VOS_DEV_USBHOST_2 0
#define VOS_DEV_USBHOST_FT232 1
#define VOS_DEV_GPIOA 2
#define VOS_DEV_GPIOC 3
/**
 * VOS HANDLES
 */
VOS_HANDLE hUSBHOST_2; // USB Host Port 2
VOS_HANDLE hUSBHOST_FT232;
// Connects to FT232 devices using the USB Host Interface
VOS_HANDLE hGPIOA; //Vinculum-II GPIO_PORT_A
VOS_HANDLE hGPIOC; //Vinculum-II GPIO_PORT_C
/**
 * GLOBAL DEFINITIONS
 */
#define LED1 0x01
#define LED2 0x02

//open the I/O port device
hGPIOA = vos_dev_open(VOS_DEV_GPIOA);
```

Keep reading and you'll get the scoop on all of the VOS devices and VOS handles in the open device code snippet that we have yet to discuss. For now, concentrate on all things GPIOA. With the issuance of the *vos\_dev\_open* command, we have just associated the Vinculum-II's GPIO\_PORT\_A device with a handle we defined as hGPIOA. The hGPIOA and hGPIOC I/O port handles will be used in VOS IOCTL commands to identify the I/O port that the command and data in the control block should act upon. For instance, let's write some code to set the LED1 and LED2 positions of GPIO\_PORT\_A as outputs. We'll stuff our PORTA IOCTL control block instance (*gpio\_iocbA*) with the command code (*ioctl\_code*) and variable (*value*) necessary to set the LED1 and LED2 port pin directions:

```
//set lower 2 bits of GPIO_PORT_A (A0 and A1)
//as outputs
gpio_iocbA.ioctl_code = VOS_IOCTL_GPIO_SET_MASK;
gpio_iocbA.value = 0x03; // set lower 2 bits
as outputs
vos_dev_ioctl(hGPIOA, &gpio_iocbA);
```

The function *vos\_dev\_ioctl* uses the handle we obtained when we opened the GPIOA device (hGPIOA) to direct the contents of I/O control block *gpio\_iocbA* to the IOCTL subsystem of GPIO\_PORT\_A.

At this point, we have everything in place that will allow us to control the state of LED1 and LED2. So, let's assemble some Vinculum-II code to illuminate LED1:

```
uint8 ledmask;
#define LED1 0x01

ledmask &= (~LED1); //0b11111110
vos_dev_write(hGPIOA, &ledmask, 1, NULL);
//write 1 byte to GPIO_PORT_A
```

Again, we used the device handle (hGPIOA) to tell the VOS device write function where to send the single byte

of *ledmask* data. Okay. Let's extinguish LED1:

```
uint8 ledmask;
#define LED1 0x01

ledmask |= LED1; //0b00000001
vos_dev_write(hGPIOA, &ledmask, 1, NULL);
```

In the calling of the *vos\_dev\_write* function, we have invoked the services of the Device Manager to manipulate the state of LED1. The Device Manager sits between the user's application code and the Vinculum-II device drivers. When we issued the *vos\_dev\_open* command for device VOS\_DEV\_GPIOA, the Device Manager determined and assigned the handle value for hGPIOA. From the VOS point of view, the handle hGPIOA will be used exclusively to communicate with the GPIO\_PORT\_A device. The following device driver functions are available via the Device Manager:

```
vos_dev_open()
vos_dev_close()
vos_dev_read()
vos_dev_write()
vos_dev_ioctl()
```

Once a device is opened, we have exclusive access to the device via the handle we obtained from the Device Manager. The handle and access to the device are relinquished upon the issuance of *vos\_dev\_close()*.

You'll find that the control block/VOS command methodology is used liberally in the coding of the Vinco hardware. Let's base our coding style on that concept and assemble some USB device driver and application code.

## THE SENA PROBEE ZU10

I was experimenting with a pair of these ZigBee modules and noticed that the Windows "Found USB Device" message indicated that the discovered USB device was of the FTDI FT232 class. So, I loaded up FTDI's FT\_PROG utility and scanned one of the ProBee ZU10 modules just to be sure. The contents of **Screenshot 2** confirmed my sighting. The ProBee ZU10 pictured in **Photo 3** is a SENA ZigBee radio with an FT232 USB-to-UART front end. Obviously, it is designed to plug into a PC running FTDI host drivers. We're going to take advantage of the FTDI front end and the fact that the ProBee ZU10 responds to a modified version of the AT command set to drive the ProBee ZU10 ZigBee radio with our Vinco. Basically, we need to enumerate the ProBee ZU10 module, determine what the USB device really is and what it can or cannot do, present a compatible host interface, and start talking to the device.

Before we dive into the construction of the ProBee ZU10 driver/application code, get a copy of the download package associated with this discussion. It contains a full listing of the Vinculum-II ProBee ZU10 driver source code. It would also be helpful to download a copy of the Vinco datasheet. There you will find a complete schematic of the Vinco module. Having the aforementioned items in hand will make the Vinculum-II

hardware-to-firmware associations a bit easier to follow.

## THE MAIN CODE

We'll begin by laying the ground work for our ProBee ZU10 application in the *main* function. Unlike C, the contents of the Vinculum-II *main* function are only executed once. Initialization processes and context spawning normally take place within the *main* function. When all of the initialization tasks are complete, the VOS scheduler is started. With the scheduler running, there is no longer a need for the code in the *main* function. However, we don't want anything in the application to cause the code to reenter the *main* function. So, the last instructions in the Vinculum-II *main* function form a super tight endless loop:

```
main_loop:
goto main_loop;
```

Hosting the ProBee ZU10 is in our Vinco's future. So, it's logical that there would be the need for a USB host context. Creating our instance of the host context follows the same C language rules that our GPIO instantiations followed:

```
// Context for USB Host template in USBHost.h
typedef struct _usbhost_context_t {
    // number of interfaces both USB
    //hosts combined
    unsigned char if_count;
    // number of endpoints (excluding control
    //endpoints) expected
    unsigned char ep_count;
    // number of concurrent transaction
    //unsigned char xfer_count;
    // number of concurrent isochronous
    //transactions expected
    unsigned char iso_xfer_count;
} usbhost_context_t;

usbhost_context_t usbhostContext;
```

It would be folly to instantiate a USB host context and not use it. Here's the filler:

```
// Initialize USB Host
usbhostContext.if_count = 8;
usbhostContext.ep_count = 16;
usbhostContext.xfer_count = 2;
usbhostContext.iso_xfer_count = 2;
usbhost_init(-1, VOS_DEV_USBHOST_2,
&usbhostContext);
```

In this case, the "filler" for the *usbhostContext* was generated by the Vinculum-II IDE Project Wizard. Once the *usbhostContext* structure is populated, its contents are used in the host initialization. The -1 in the *usbhost\_init* call represents the Mini-B USB portal which is not used in the ProBee ZU10 application. Only the USB port with the Type A USB interface is activated (VOS\_DEV\_USBHOST\_2).

Driving an LCD could also be in our Vinco's future and I've taken the liberty to plan for that in the IOMUX configuration:

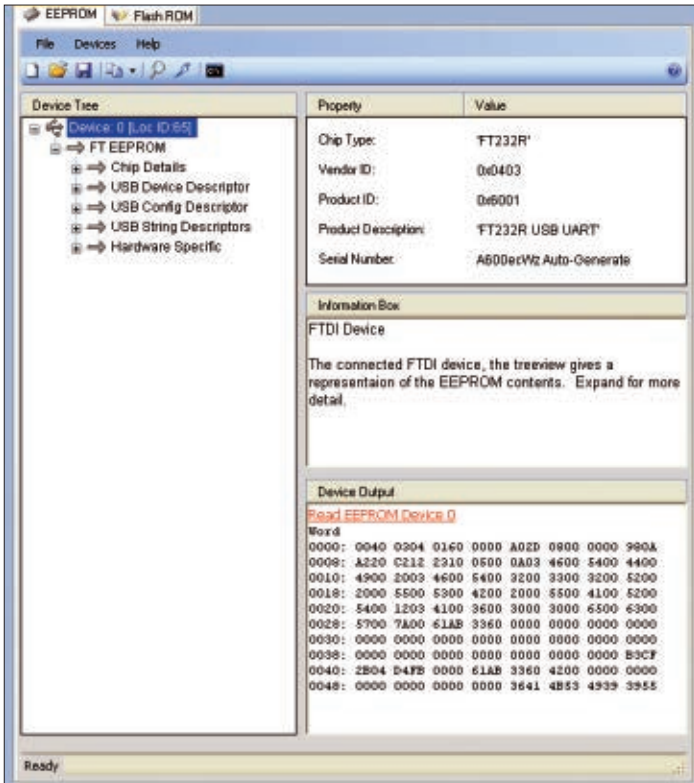

■ **SCREENSHOT 2.** The FTDI FT\_PROG utility is a free download from the FTDI site. This utility reveals what type of FTDI IC is plugged into the USB portal and what it is programmed to do. You can also use this utility to program an attached FTDI FT232RL device.

ride on the Vinco's unused PORTC pins. I used the VNC2 IOMUX config utility to add the PORTC LCD definitions. Everything we did to get PORTA operational is also done for PORTC within the *main* function.

The Vinculum-II API provides a host driver that is written specifically to drive FTDI-based slave devices like the FT232R in our ProBee ZU10 module. Once the core USB host is established, the FT232 host driver is logically attached to it in the ProBee ZU10 application code. We initialize the FT232R host driver in the *main* function:

```
// Initialize USB Host FT232 Driver
usbHostFt232_init(VOS_DEV_USBHOST_FT232);
```

The thread called *firmware* holds all of the application code and falls under the control of the VOS scheduler. You can operationally think of the Vinculum-II *firmware* function as a standard C *main* function. The major difference is that there can be multiple thread functions in a Vinculum-II application code set. The ProBee ZU10 application contains a single thread. Here's how we created it:

```
//*****
//*      VOS APPLICATION THREADS
//*****
vos_tcb_t *tcbFIRMWARE;

tcbFIRMWARE = vos_create_thread_ex(20, 4096,
firmware, "Application", 0);
```

As you would expect, *vos\_tcb\_t* is a structure located in the *vos.h* file. Our thread (*firmware*) is tied to an instance of *vos\_tcb\_t* via the pointer *tcbFIRMWARE*. Now that we have a place to run some code, we can start the scheduler:

```
vos_start_scheduler();
```

The *main* function can now be jettisoned to endless loop land.

## THE APPLICATION CODE

Take a look inside of the *firmware* thread. You will see that all of the USB host and GPIO control blocks are instantiated inside of the *firmware* braces. You will also find that the necessary devices are opened and their associated handles are assigned with the confines of the *firmware* thread. Hardware and firmware

```
// Configure IOMUX
// GPIO Port A 0 to pin 39 as Output.
vos_iomux_define_output(39,
IOMUX_OUT_GPIO_PORT_A_0); // LED1#
// GPIO Port A 1 to pin 40 as Output.
vos_iomux_define_output(40,
IOMUX_OUT_GPIO_PORT_A_1); // LED2#
// GPIO Port A 2 to pin 41 as Output.
vos_iomux_define_output(41,
IOMUX_OUT_GPIO_PORT_A_2); // PWREN#
// GPIO Port C 0 to pin 24 as Output.
vos_iomux_define_output(24,
IOMUX_OUT_GPIO_PORT_C_0); // DB4
// GPIO Port C 1 to pin 25 as Output.
vos_iomux_define_output(25,
IOMUX_OUT_GPIO_PORT_C_1); // DB5
// GPIO Port C 2 to pin 26 as Output.
vos_iomux_define_output(26,
IOMUX_OUT_GPIO_PORT_C_2); // DB6
// GPIO Port C 3 to pin 27 as Output.
vos_iomux_define_output(27,
IOMUX_OUT_GPIO_PORT_C_3); // DB7
// GPIO Port C 4 to pin 28 as Output.
vos_iomux_define_output(28,
IOMUX_OUT_GPIO_PORT_C_4); // RS
// GPIO Port C 5 to pin 29 as Output.
vos_iomux_define_output(29,
IOMUX_OUT_GPIO_PORT_C_5); // E
```

The addition of the active-low PWREN# gives us a programmable way to apply USB host power to the ProBee ZU10 via the Type A USB portal. The LCD will



■ **PHOTO 3.** There is a complete ZigBee radio behind that USB connector. All we have to do is figure out how to talk to it without plugging the ProBee ZU10 into a PC.



application initialization tasks are also performed within the *firmware* thread before passing control to the application state machine. To make the code easier to follow, the ProBee ZU10 driver application is divided into sections called states. Each state performs a specific task. As each state completes its task, the “ball” gets passed to the next logical state. There are currently eight states in our ProBee ZU10 driver application:

```

//*****
/** STATES
//*****
enum {
    sENUM = 0,           //enumerate the ProBee ZU10
    sFIND_DEVICE,      //get ProBee ZU10
                        //configuration parms
    sATTACH_FT232,     //logically attach the
                        //FT232RL host to the
                        //core host
    sSETUP,            //send initial AT commands
    sRX_FT232,         //receive from the ProBee
                        //ZU10
    sTX_FT232,         //send to the ProBee ZU10
    sPROCESS_FT232,   //process the received data
    sERROR             //error processing
};

```

If we can get the ProBee ZU10 to enumerate, we’re on our way. Here’s the code that stands between us and the ProBee ZU10’s USB enumeration:

```

//*****
/** ENUMERATE STATE
//*****
case sENUM:
    //power up the ProBee ZU10
    slavepwr(1);
    do
    {
        //blink the LEDs and wait for
        //enumeration to complete
        vos_delay_msecs(250);
        led(1,1);
        vos_delay_msecs(250);
        led(1,0);
        // user ioctl to see if bus available
        hc_iocb.ioctl_code = VOS_IOCTL_
        USBHOST_GET_CONNECT_STATE;
        hc_iocb.get = &portstat;
        vos_dev_ioctl(hUSBHOST_2, &hc_iocb);
    }while(portstat != PORT_STATE_ENUMERATED);
    led(1,1);
    LAST_STATE = sENUM;
    CURRENT_STATE = sFIND_DEVICE;
break;

```

The enumeration code speaks for itself. The user-written (that’s us) *slavepwr* and *led* functions apply power to the ProBee ZU10 and provide a visual indication as to the success of the enumeration. Note the use of the Device Manager handle/control block command combination (*vos\_dev\_ioctl(hUSBHOST\_2, &hc\_iocb)*) to determine the USB port state. Once the ProBee ZU10 is enumerated, application control is passed to the *sFIND\_DEVICE* state:

```

#define USB_VID_FTDI      0x0403
//declared in USB.h

#define USB_PID_FTDI_FT232 0x6001
//declared in USB.h

```

```

//*****
/** FIND DEVICE STATE
//*****
case sFIND_DEVICE:
    // find FTDI vendor device (ProBee ZU10)
    hc_iocb_vendor.vid = USB_VID_FTDI;
    hc_iocb_vendor.pid = USB_PID_FTDI_FT232;
    // user ioctl to find first hub device
    hc_iocb.ioctl_code = VOS_IOCTL_USBHOST_
    DEVICE_FIND_HANDLE_BY_VID_PID;
    hc_iocb.handle.dif = NULL;
    hc_iocb.set = &hc_iocb_vendor;
    hc_iocb.get = &ifDev;
    if (vos_dev_ioctl(hUSBHOST_2, &hc_iocb)
    != USBHOST_OK)
    {
        LAST_STATE = sFIND_DEVICE;
        CURRENT_STATE = sERROR;
        break;
    }
    hc_iocb.ioctl_code = VOS_IOCTL_
    USBHOST_DEVICE_GET_VID_PID;
    hc_iocb.get = &hc_iocb_vendor;
    vos_dev_ioctl(hUSBHOST_2, &hc_iocb);
    myVID = hc_iocb_vendor.vid;
    myPID = hc_iocb_vendor.pid;
    led(2,1);
    LAST_STATE = sFIND_DEVICE;
    CURRENT_STATE = sATTACH_FT232;
break;

```

I mixed business with pleasure in the *sFIND\_DEVICE* state code. I instructed the Vinculum-II to attempt to find the ProBee ZU10 on the Vinco’s Type A USB interface using the FTDI standard VID and PID values listed in *USB.h*. If the ProBee ZU10 was found to be mounted in the Type A USB portal, I added some gravy code that fetched the ProBee ZU10’s VID and PID values. Everything worked as designed. The ProBee ZU10 enumerated and I caught the ProBee ZU10’s regurgitated VID and PID values in the Vinculum-II IDE debugger:

```

myVID 0x00000403
myPID 0x00006001

```

We’ve hit pay dirt. The ProBee ZU10 enumerated and we were able to communicate with its internals. However, to enable data transfer via the ProBee ZU10’s SENA radio, we need to attach the FT232-friendly host driver to the core USB host driver. The FT232 IC is doing its part on the SENA radio/UART side. We need to enable a communications method on the FT232 IC’s USB side. That’s why the *sFIND\_DEVICE* state passed application control to the ATTACH FT232 HOST state:

```

//*****
/** ATTACH FT232 HOST STATE
//*****
case sATTACH_FT232:
    // we have a device, initialize a driver
    //for it
    hUSBHOST_FT232 = vos_dev_open(VOS_
    DEV_USBHOST_FT232);

    // ft232_attach
    ft232_att.hc_handle = hUSBHOST_2;
    ft232_att.ifDev = ifDev;

    ft232_iocb.ioctl_code = VOS_IOCTL_
    USBHOSTFT232_ATTACH;
    ft232_iocb.set = &ft232_att;

    if (vos_dev_ioctl(hUSBHOST_FT232,
    &ft232_iocb) != USBHOSTFT232_OK)

```

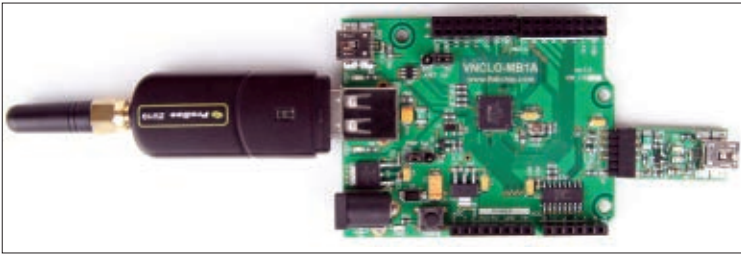

■ **PHOTO 4.** The VNC2 programmer/debugger allows the capture of data to the Vinculum-II IDE's WATCH window without having to pipe the data out to a terminal emulator or LCD.

WATCH window, I set a breakpoint at the `toggle_led(2)` statement.

```
{
    LAST_STATE = sATTACH_FT232;
    CURRENT_STATE = sERROR;
    break;
}

// ProBee runs at 9600 baud
ft232_iocb.ioctl_code = VOS_IOCTL_
USBHOSTFT232_SET_BAUD_RATE;
ft232_iocb.set_uart_baud_rate =
USBHOSTFT232_BAUD_9600;
vos_dev_ioctl(hUSBHOST_FT232,
&ft232_iocb);
ft232_iocb.ioctl_code =
VOS_IOCTL_USBHOSTFT232_START_POLL;
vos_dev_ioctl(hUSBHOST_FT232,
&ft232_iocb);
LAST_STATE = sATTACH_FT232;
CURRENT_STATE = sSETUP;
break;
```

Use what you learned in the LED code and you'll have no problem figuring out what's going on in the `sATTACH_FT232` state code. The FT232 host driver is "attached" to the core USB host. Following the attachment, the Vinco takes on the persona of a PC running FTDI drivers. When polling is kicked off, we're ready to instruct the Vinculum-II to send and receive data using the ProBee ZU10's ZigBee radio. The ProBee ZU10/Vinco/debugger hardware setup is under the Canon lens in **Photo 4**.

## SEND DATA

This code sends '1A6' to the ZigBee Coordinator and every other node in the PAN:

```
rom char msgBC[19] = {0x12,'A','T','+', 'B',
'R','O','A','D','C','A','S','T','=','1','A','6',0
x0D,0x0A};
uint8 send_msg(void)
{
    uint8 i;
    uint8 status;

    num_to_write = msgBC[0];
    j=1;
    for(i=0;i< num_to_write;i++)
    {
        wbuffer[i] = msgBC[j++];
    }

    status=vos_dev_write(hUSBHOST_FT232,
wbuffer, num_to_write, &num_written);
    return(status);
}
```

The `send_msg` function is invoked by the `sTX_FT232` state.

## RECEIVE DATA

To view the incoming data in the Vinculum-II IDE

```
uint8 rbuffer[64];
uint16 num_received, num_read;

//*****
//* FT_232 RECEIVE STATE
//*****
case sRX_FT232:
    // wait for data to be received on FT232
    // device
    ft232_iocb.ioctl_code = VOS_IOCTL_
COMMON_GET_RX_QUEUE_STATUS;
    vos_dev_ioctl(hUSBHOST_FT232,
&ft232_iocb);
    num_received = ft232_iocb.get.queue_stat;

    if (num_received > 64)
        num_received = 64;
    if (num_received)
    {
        // read data into buffer
        if(vos_dev_read(hUSBHOST_FT232, rbuffer,
num_received, &num_read)!= USBHOSTFT
232_OK)
        {
            LAST_STATE = sRX_FT232;
            CURRENT_STATE = sERROR;
            break;
        }
        LAST_STATE = sRX_FT232;
        CURRENT_STATE = sPROCESS_FT232;
    }
    toggle_led(2);
    vos_delay_msecs(50);
break;
```

Note that we're accessing the overlaid FT232 host driver and not the core USB host driver.

## EASY ZIGBEE

I used the ProBee Manager PC application to preconfigure one of the ProBee ZU10 modules as a ZigBee Coordinator. The ZigBee Coordinator ProBee ZU10 was attached to a PC running HyperTerminal. The ProBee ZU10 module driven by the Vinco was set up to be a sleepy end device. I also used the ProBee Manager to configure both of the ProBee ZU10 modules to set up a ZigBee PAN (Personal Area Network) automatically. So, while we were busy with making sure we were taking care of FTDI USB business, the ProBee ZU10 modules were taking care of ZigBee network business. For the hardcore of you, yes, we could have used ProBee ZU10 AT commands to set up the ProBee ZU10 modules using the Vinco.

The LCD driver is included within the Vinco/ProBee ZU10 application source code in the download package. Everything you need to host the ProBee ZU10 with a Vinculum-II is there and then some. Chalk up two more disciplines to your Design Cycle: Vinculum-II and the ProBee ZU10. **NV**

Europe's leading prototype supplier now also in America

**Order direct from our US facility!**

PCB-POOL RULES!

DAS ORIGINAL SEIT 1994  
**PCB-POOL**<sup>®</sup>  
Beta LAYOUT

**order!**  
PCBs 1-6 layers

**free!**  
Free Stencil

**fast!**  
8 hour service

**NEW!**

**cool!**  
Aluminium-Core IMS PCBs

**Beta**  
LAYOUT

www.pcb-pool.com

email : [sales@beta-layout.us](mailto:sales@beta-layout.us)  
Toll Free USA : 888-977-7443

All registered brands remain the registered trademarks of the respective manufacturer!

Continued from page 26



family consists of three models covering all levels of digital logic instruction. The DL-010 Combinational Logic Trainer teaches the initial concepts of AND, OR, and XOR gates. The DL-020 Sequential Logic Trainer introduces the concept of conditional feedback and includes D Flip-flop, NAND gates, and a 4-to-1 multiplexer; both models are now available to ship from stock. Lastly, the DL-030 is a microprocessor trainer that employs an FPGA chip, allowing a user to fully implement a functioning microcontroller in minutes. These logic trainers simplify the teaching process by eliminating the need to discretely wire ICs as all components are pre-mounted, decoupled, and de-bounced, ready for immediate classroom use. Most importantly, each trainer includes a training manual featuring overviews of digital logic and over 60 corresponding hands-on exercises enhancing any existing textbook currently in use.

The trainers are packaged in sturdy blow-molded cases and come complete with a power supply and machined pin hookup wires.

For more information, contact:  
**Global Specialties, LLC**  
 22820 Savi Ranch Parkway  
 Yorba Linda, CA 92887  
 Tel: 800-572-1028  
 Web:  
[www.globalspecialties.com](http://www.globalspecialties.com)

## NEW 200 MHz MSO TYPE HMO2024



In electronics, continuing integration has risen to a level which requires a broad range of features available only in the mid-range class — until now, with the extension of Hameg's popular HMO series by eight instruments (two-, four-channel, 70 to 200 MHz).

With the new two-channel 70 MHz instrument (HMO722), the serial triggering and decoding of I<sup>2</sup>C, SPI, and UART/RS-232 protocols can be performed via the analog channels. With three-conductor buses, the external trigger input is also used.

All instruments are MSO ready and (after buying a logic probe HO3508) can be upgraded with eight logic channels. Standard features are a powerful mask test, extended mathematics, (e.g., integration or digital filters), an integrated source of square wave signals, up to four bits wide random or counter patterns, I<sup>2</sup>C, SPI, and UART signals with different data rates, and a component tester. Also unique is the sensitivity of 1 mV/div.

For more information, contact:  
**HAMEG Instruments**  
 Web: [www.hameg.com](http://www.hameg.com)

## THE HS-5035HD DIGITAL ULTRA NANO

Hitec's new, ultra nano HS-5035HD is the digital version of their popular HS-35HD. Equipped with a fully programmable digital circuit, Metal Karbonite™ gear train,

and long life potentiometer, the HS-5035HD provides heavy hitting performance in a lightweight package. Pilots of micro 3D and sport aircraft, as well as small helicopters, will find it the perfect servo for aerial theatrics.



### Features:

- Ultra-light weight nano size.
- Fully programmable digital circuit.
- Long life potentiometer.
- Metal Karbonite™ gear train.
- Multi-directional servo cable joint.
- Available with standard and micro connectors.
- Estimated Street Price: \$34.99

For more information, contact:  
**Hitec**  
 12115 Paine St.  
 Poway, CA 92064  
 Web: [www.hitecrd.com](http://www.hitecrd.com)

## ExpressModule™ INTERPOSER TO SUPPORT PCI EXPRESS® 3.0 PROTOCOL ANALYSIS

LeCroy Corporation has introduced a new PCI Express® (PCIe®) ExpressModule™ interposer that supports PCI Express 3.0 specification data rates up to 8 GT/s. The new ExpressModule interposer — designed for use with the LeCroy Summit™ T3-16 and T3-8 PCI Express protocol analyzers — provides the ability to easily analyze data traffic between high performance ExpressModule HBA cards and ExpressModule-based blade server systems.

An ExpressModule is an I/O HBA card based on the PCI Express specification that is mechanically inserted into an ExpressModule-compatible blade server backplane. The ExpressModule HBA technology enables higher reliability,

performance, and manageability providing high speed performance utilizing PCI Express 3.0 specification speeds of up to 8 GT/s.

Debugging the protocol traffic between the PCI Express 3.0 ExpressModule and chassis backplane can be challenging due to tight mechanical tolerances. The PCI Express 3.0 ExpressModule interposer connects between the backplane of the chassis and the ExpressModule, and enables the analyzer to capture, decode, and display all traffic on the PCI Express bus for troubleshooting, debugging, and monitoring system performance. This new interposer minimizes signal interference by using LeCroy's T.A.P.(3) technology, allowing protocol traffic between the ExpressModule and backplane to be analyzed while inside the chassis. This insures that the equipment under test can function normally while data traffic is analyzed, so that any protocol problems can be quickly identified and solved. The ExpressModule interposer is offered in x1, x4, and x8 lane widths.

For more information, contact:  
**LeCroy Corporation**  
 Tel: 800-5LeCroy  
 Web: [www.lecroy.com](http://www.lecroy.com)

## ADVANCED DEVELOPMENT KIT FOR HIGH QUALITY DIGITAL AUDIO APPLICATIONS



**M**icrochip Technology, Inc., has announced a 32-bit microcontroller (MCU)-based development kit for the creation of high quality, 24-bit audio

applications. The Audio Development Board for PIC32 MCUs features an 80 MIPS PIC32 MCU, a 24-bit Wolfson audio codec, a two inch color LCD display, a USB interface, and an on-board microphone. Supported by Microchip's free software libraries, the kit provides a solution for the development of speech, and audio recording and playback products.

The 80-MIPS PIC32MX795F12L MCU on the audio development board features 512 KB Flash and 128 KB RAM, providing plenty of processing power and memory to decode, analyze, and play back audio and speech. Libraries are available for speech recording and playback, as well as MP3 music decoding applications. Additionally, an audio Sample Rate Conversion (SRC) library for 33 kHz, 44.1 kHz, and 48 kHz is also supported, which enables developers to reduce component costs for playback solutions.

There are also libraries available for managing the USB interface and driving the on-board color LCD display which features 16-bit color images. For those developers who are enrolled in the Apple® Made For iPod (MFi) Licensing Program, the kit also interfaces to Microchip's accessory development platform for iPod® and iPhone®.

The audio development board is available for \$149.99.

For more information, contact:  
**Microchip Technology, Inc.**  
 Web: [www.microchip.com](http://www.microchip.com)

## VPN1513 GPS RECEIVER MODULE

**T**he VPN1513 GPS receiver Module from Parallax provides a fully open source and customizable GPS receiver solution for microcontroller projects. The VPN1513 uses a SiRF Star III chipset capable of tracking up to 20 satellites. The module supports both "raw" output mode for raw NMEA



0183 strings and the default "smart" mode for specific user-selected data through a serial interface.

The VPN1513 GPS receiver module also features a Propeller co-processor for easy interface with any BASIC Stamp 2 module. The Propeller is also fully reprogrammable and includes access to all 32 IO pins, allowing the GPS receiver module to be easily transformed into a standalone device. Price is \$59.99.

### Features:

- Track up to 20 satellites.
- Fast satellite acquisition time.
- High tracking sensitivity (-159 dBm).
- Navigation update rate of once per second.
- Position accuracy of ± 10 meters; 2D RMS ± 5 meters.
- Velocity accuracy of ± 0.1 meters per second.
- Maximum altitude of 18,000 meters.
- Propeller co-processor allows for easy transition to a stand-alone device.
- On-board LED for satellite acquisition feedback.
- Nine ft external antenna w/MCX connector included.
- Battery-backed SRAM and RTC.
- Fully open source design.

For more information, contact:  
**Parallax, Inc.**  
 Web: [www.Parallax.com](http://www.Parallax.com)

*Is your product innovative, less expensive, more functional, or just plain cool? If you have a new product that you would like us to run in our New Products section, please email a short description (300-500 words) and a photo of your product to:*

**newproducts@nutsvolts.com**

# READER-TO-READER TECHFORUM

Send all questions and answers by email to [forum@nutsvolts.com](mailto:forum@nutsvolts.com)  
Check at [www.nutsvolts.com](http://www.nutsvolts.com) for tips and info on submitting to the forum.

All questions AND answers are submitted by *Nuts & Volts* readers and are intended to promote the exchange of ideas and provide assistance for solving technical problems. Questions are subject to editing and will be published on a space available basis if deemed suitable by the publisher. Answers are submitted by

readers and **NO GUARANTEES WHATSOEVER** are made by the publisher. The implementation of any answer printed in this column may require varying degrees of technical experience and should only be attempted by qualified individuals. *Always use common sense and good judgment!*

## >>> QUESTIONS

### Voltage Problem?

We would like to plug our credit card terminal into one of our Vodavi Starplus STSe telephone system's SLT ports so that we can use the system's "off hook preference" feature to find another unused line if the usual line is already in use. However, the credit card terminal needs more power than the 22V provided by the KSU's single line port which drops to 8V when in use. Sometimes the terminal says "no line" and other times it does connect but cannot communicate because something inside the terminal is causing a clicking noise as if it were rapidly connecting and disconnecting – although it does send the DTMF dialing signals in spite of the clicking. (Our phone company provides 50V which drops to 12V, which works fine for the terminal. We have tried our fax machine on the same KSU port we're trying to connect the terminal to and it works very well, so we know the port is programmed correctly.) I have tried simply adding a 9V battery in series and it solved the original problem 100% – no clicking, no "no line" message, and the KSU found an unused line just fine. However, the phone company no longer was able to recognize the DTMF dialing which is not surprising, but it proved that the problem is indeed caused by too low voltage. (We could, of course, simply get an extra phone line, but people in *Nuts & Volts* land try to patronize the phone company as a last resort!) Can anyone suggest a circuit that would increase the power going from the KSU to the terminal without disturbing the signals?

**#9111** **Leroy Sensenig**  
**Penn Yan, NY**

### Aquatic Sounds Detector

I intend to build an instrument similar to the one described in the June '11 *Nuts & Volts* article, *Build a Bat*

*Detector* by Jonathan Berber. The instrument I hope to build will be used in an aquatic environment – both fresh and marine waters – to monitor sounds produced by fish and other aquatic life. I would like to get more information or at least get pointed in a direction where I could find help with the design and development of this project.

1.) Does anyone know of others doing this type of aquatic acoustic observation and the type of instruments being used in their program?

2.) Can anyone recommend software to be used on a laptop for this type of monitoring?

3.) What type of hydrophones should be used in fresh water and in ocean water?

I hope someone can provide help or leads to get me started.

**#9112** **Richard W. Kotsch**  
**Indian, AK**

### Increase Resolution

How do I increase the resolution of a variable resistor (pot)? I have to move the knob so slightly that I can't fine-tune or properly adjust the resistance in the circuit. Any type of solution would be appreciated.

**#9113** **Michael Cimkowski**  
**East Rockaway, NY**

### DC to AC Power

I'm looking for a small inverter circuit that can supply 200 mA, 12 VDC input, and 9 VAC output. A small and compact circuit would be ideal.

**#9114** **Tom Farkas**  
**Shoreline, WA**

## >>> ANSWERS

### [#7113 - July 2011] Resistance Amplifier

*I was wondering if someone knows how to design a circuit to measure resistance. I would like to jumper select the input range, run it through a zero*

*and span circuit, and output a 0-10 VDC signal inversely proportional to the selected resistance range.*

*As the resistance goes down to the bottom of the range, the output would increase to the maximum (10 volts). As the resistance increases to the maximum of the range, the voltage on the output would go down to zero. As with all analog designs, linearity is important. I have seen circuit boards that do this. They have two eight-pin chips on them, two trimmers, and a small assortment of misc. parts. Simple is good.*

*Producing a suitable power supply for this circuit is the easy part, so I can come up with that on my own.*

Consider the non-inverting voltage amplifier of **Figure 1**. Normally, we construct it with V connected to ground, but we don't have to. To compute the voltage at A for any output, observe that the voltage A-V is across R while the voltage Out-V is across X+R, and the currents are the same through both resistors, so:

$$\frac{A-V}{R} = \frac{Out-V}{X+R}$$

Skipping all of the tedious algebra while solving for Out – and realizing that it is an op-amp's job to keep its two inputs equal by changing its output – thus A = VRef. We get:

$$Out = (VRef - V) \times \frac{X}{R} + VRef$$

So, if you want the output to be 10V when X is zero, VRef must be 10V. Skipping more algebra while solving for the ratio of X to R when Out is zero, we get:

$$N = \frac{X}{R} = \frac{VRef}{V - VRef}$$

So, with V = 12V and VRef = 10V, the multiplier N is 5, i.e., the output is zero when X is five times R. Alternately, a V of 11V gets a multiplier, N, of 10. Though some op-amps are rail-to-rail, they still have difficulty getting all the way there. It's best to use a bi-polar

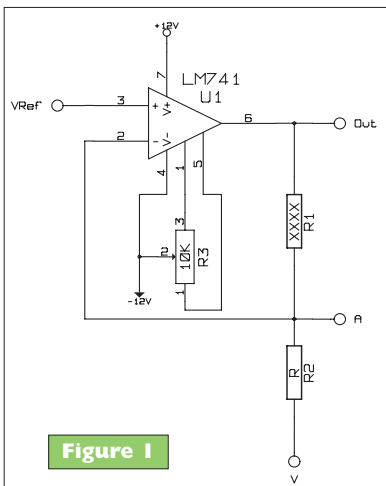

supply with enough head space to let the op-amp be comfortable and stay linear. Since no negative voltages are used, the negative supply only needs to be low enough to give clearance and can be any voltage lower than about -1.5V. You may want to use a second op-amp from a dual package as an output buffer (voltage follow-

er), depending on the intended load. You can change V or R or both to change the range. Changing VRef changes both the span and the range. Use the offset adjust (R3) to make the output 10V when X is zero. Since there are tens of thousands of op-amps to choose from, it is probably best to look to your favorite store, see what they have, and consult the spec sheets. For increased accuracy, you could choose an instrumentation op-amp. The bandwidth is probably irrelevant depending on just what the resistance source is and how fast it changes.

**Jim Brannan**  
Santa Clara, CA

## Custom Front Panels & Enclosures



Sample price \$57.32 + S&H

Designed by you using our  
**FREE software, Front Panel Designer**

- Cost effective prototypes and production runs
- Powder-coated finish and panel thickness up to 10mm now available
- Choose from aluminum, acrylic or customer provided material
- 1, 3 and 5-day lead times available

**FRONT PANEL EXPRESS**

**FrontPanelExpress.com**  
**(206) 768-0602**

### AMATEUR RADIO AND TV

McGills Warehouse	50
Ramsey Electronics, Inc.	20-21
V-Module	42

### BATTERIES/CHARGERS

Cunard Associates	27
-------------------	----

### BUYING ELECTRONIC SURPLUS

Jaycar Electronics	57
Weirdstuff Warehouse	27

### CCD CAMERAS/VIDEO

Circuit Specialists, Inc.	82-83
Ramsey Electronics, Inc.	20-21

### CIRCUIT BOARDS

AP Circuits	33
Cunard Associates	27
Digilent	19
Dimension Engineering	9
ExpressPCB	55
Front Panel Express LLC	79
PCB Pool	75
Saelig Company Inc.	33
V-Module	42

### COMPONENTS

Can Kit Corp.	63
Electronix Express	13
Fun Gizmos	27
Noritake	32
V-Module	42

### COMPUTER

<b>Hardware</b>	
Noritake	32
Weirdstuff Warehouse	27
<b>Microcontrollers / I/O Boards</b>	

Abacom Technologies	42
Bitscope	4
Chipino	27
Fun Gizmos	27
I! Controls	51
microEngineering Labs	5
MikroElektronika	3
Parallax, Inc.	Back Cover
Pololu Robotics & Electronics	43
Solarbotics/HVW	9

### DESIGN/ENGINEERING/REPAIR SERVICES

Can Kit Corp.	63
ExpressPCB	55
Front Panel Express LLC	79
PCB Pool	75

### EDUCATION

BaneBots	8
Bitscope	4
Blue Wolf	25
Command Productions	25
Digilent	19
Global Specialties	7
GSS Tech Ed	50
McGills Warehouse	50
NKC Electronics	27
PAIA	33
Poscope	18

### EMBEDDED TOOLS

I! Controls	51
NetBurner	2

### ENCLOSURES

Front Panel Express LLC	79
Integrated Ideas & Tech.	41

### KITS & PLANS

Can Kit Corp.	63
GSS Tech Ed	50
Jaycar Electronics	57
NetBurner	2
NKC Electronics	27
PAIA	33
QKITS	27
Ramsey Electronics, Inc.	20-21
Solarbotics/HVW	9

### MISC./SURPLUS

All Electronics Corp.	81
Front Panel Express LLC	79
Weirdstuff Warehouse	27

### MOTORS

BaneBots	8
----------	---

### OPTICS

Noritake	32
----------	----

### PROTOTYPING & TRAINERS

Global Specialties	7
--------------------	---

### PROGRAMMERS

microEngineering Labs	5
MikroElektronika	3

### RF TRANSMITTERS/RECEIVERS

Abacom Technologies	42
Blue Wolf	25
Twin Peaks Robotics	27

### ROBOTICS

BaneBots	8
Blue Wolf	25
Digilent	19
Fun Gizmos	27
GSS Tech Ed	50
Lemos International Co., Inc.	27
Lynxmotion, Inc.	49
Pololu Robotics & Electronics	43
Robot Power	27
Solarbotics/HVW	9
Twin Peaks Robotics	27

### SATELLITE

Lemos International Co., Inc.	27
-------------------------------	----

### TEST EQUIPMENT

Bitscope	4
Circuit Specialists, Inc.	82-83
Dimension Engineering	9
Global Specialties	7
Jaycar Electronics	57
McGills Warehouse	50
NKC Electronics	27
Poscope	18
Saelig Company Inc.	33

### TOOLS

MikroElektronika	3
NetBurner	2
PanaVise	13
Poscope	18

### WIRELESS PRODUCTS

Twin Peaks Robotics	2
---------------------	---

Abacom Technologies	42
All Electronics Corp.	81
AP Circuits	33
BaneBots	8
Bitscope	4
Blue Wolf	25
Can Kit Corp.	63
Chipino	27
Circuit Specialists, Inc.	82-83
Command Productions	25
Cunard Associates	27
Digilent	19
Dimension Engineering	9
Electronix Express	13
ExpressPCB	55
Front Panel Express LLC	79
Fun Gizmos	27
Global Specialties	7
GSS Tech Ed	50
I! Controls	51
Integrated Ideas & Tech.	41
Jaycar Electronics	57
Lemos International Co., Inc.	27
Lynxmotion, Inc.	49
McGills Warehouse	50
microEngineering Labs	5
MikroElektronika	3
NetBurner	2
NKC Electronics	27
Noritake	32
PAIA	33
PanaVise	13
Parallax, Inc.	Back Cover
PCB Pool	75
Pololu Robotics & Electronics	43
Poscope	18
QKITS	27
Ramsey Electronics, Inc.	20-21
Robot Power	27
Saelig Company Inc.	33
Solarbotics/HVW	9
Twin Peaks Robotics	27
V-Module	42
Weirdstuff Warehouse	27

# CLASSIFIEDS

## KITS/PLANS

**QKITS.COM**



Qkits Ltd

**50 AMP PWM**  
**1-888-GO 4 KITS**

SAM-III Geomagnetometer Kit

- ☐ 3-Axis - N-S, E-W, Vertical
- ☐ ±50,000 nT, 1-2 nT resolution
- ☐ 12 Vdc
- ☐ Complete kit includes software
- ☐ Logging with PC or standalone
- ☐ Join worldwide magnetometer network
- ☐ Starting at US\$199.95



[www.reeve.com/SAM3.htm](http://www.reeve.com/SAM3.htm)

## HARDWARE WANTED

**DEC EQUIPMENT WANTED!!!**  
Digital Equipment Corp. and compatibles.  
Buy - Sell - Trade  
CALL KEYWAYS 937-847-2300  
or email [buyer@keyways.com](mailto:buyer@keyways.com)

## ENERGY SOLUTIONS



Save Money On  
Your Electric Bill  
[www.sunny-solutions-shop.com](http://www.sunny-solutions-shop.com)  
800-315-0309

## JOB OPPORTUNITIES

Electronics company seeking part-time account representatives, sales payment and bookkeepers. Applicants must be computer literate with access to the Internet, Send resume to:  
[moore1719@gmail.com](mailto:moore1719@gmail.com)

[www.nutsvolts.com](http://www.nutsvolts.com)

High Quality  
Electronic Kits & Modules



**\$59.<sup>95</sup>**  
UK1133

**50 AMP DIGITAL PWM**  
(OPTIONAL DISPLAY)

FM Transmitters  
Timers  
Audio Amplifiers  
Motor Controllers  
PIC Programmers / Arduino

••• Custom Designs •••

[www.canakit.com](http://www.canakit.com)

**Electronic Kits**

- Fun and Educational
- Discount White and Blue LEDs
- Quantity Discounts



[www.bakatronics.com](http://www.bakatronics.com)

Looking for solar stuff to read about and build? Then check out **Nuts & Volts!**  
[www.nutsvolts.com](http://www.nutsvolts.com)

**TURTLE BEACH**

**NOW HIRING**

We're looking for motivated and talented engineers to help us create the next generation of audio products for PC, Xbox and PS3 gaming.



LEARN MORE & APPLY AT:  
[WWW.TURTLEBEACH.COM](http://WWW.TURTLEBEACH.COM)

## SURPLUS

**SURPLUS ELECTRONIC PARTS & ACCESSORIES**

	Over 18,000 Items in Stock.	Cables Connectors Displays Fans	Hardware LEDs Motors Potentiometers	Relays Semiconductors Service Manuals Speakers	Switches Test Equipment Tools VCR Parts
	Surplus Material Components SMC ELECTRONICS <a href="http://www.smcelectronics.com">www.smcelectronics.com</a>		No Minimum Order. Credit Cards and PAYPAL Accepted. Flat \$4.95 per order USA Shipping.		

## COMPONENTS

**RF PARTS™ CO.**

Tubes, Transistors, Power Components  
Email: [rpf@rfparts.com](mailto:rpf@rfparts.com) • Web: [www.rfparts.com](http://www.rfparts.com)  
**800-737-2787 Fax 888-744-1943**

**uM-FPU V3.1**  
Floating Point Coprocessor



32-bit IEEE 754  
SPI or I2C  
DIP-18, SOIC-18

**New full featured Compiler**  
Extensive floating point support,  
GPS input, FFT, 12-bit A/D, matrix  
operations, user-defined functions.

[www.micromegacorp.com](http://www.micromegacorp.com)

**LEDs**

Super Brights from 20¢  
RGB Color Mixing 30 Pack \$6.99  
Assortment 120 Pack \$24.99  
Shipping from \$3.00

[Alan-Parekh.com/Store](http://Alan-Parekh.com/Store)

## PCB SOFTWARE

EXCLUSIVE U.S. DISTRIBUTOR



**YOUR COMPLETE SOLUTION!**

- PCB Design
- PCB Simulation
- CAD/CAM Menu

121747, Hobby Vers., \$175  
121743, Pro. Version, \$275  
[www.KELVIN.com](http://www.KELVIN.com)

## DESIGN/ENG SERVICES

\* Circuit board layouts  
\* Prototype assemblies  
[WWW.OSPREYELECTRONICS.COM](http://WWW.OSPREYELECTRONICS.COM)  
Convert your sketch or print into a quality pcb for a reasonable price. Visit us on the web or call Osprey Electronics at (208) 664-1089 (USA)

## ROBOTICS

**MaxSonar**  
Ultrasonic Ranging is EZ



**LV-MaxSonar-EZ**

- Power-up calibration
- Smallest MaxSonar
- Low power, 2.5V-5.5V
- \$29.95 USD qty. 1



**MaxSonar-WR (IP67)**

- Industrial packaging
- Weather resistant
- Standard ¼" fitting
- \$99.95 USD qty. 1



**XL-MaxSonar-EZ**

- Beam pattern choice
- Real-time calibration
- High acoustic power
- \$39.95 USD qty. 1



**MaxSonar-WRC (IP67)**

- Compact packaging
- Weather resistant
- Quality narrow beam
- \$99.95 USD qty. 1

[www.maxbotix.com](http://www.maxbotix.com)

Looking for robot stuff and kits?  
[www.servomagazine.com](http://www.servomagazine.com)



# ALL ELECTRONICS

C O R P O R A T I O N

**QUALITY Parts**  
**FAST Shipping**  
**DISCOUNT Pricing**

CALL, WRITE, FAX or E-MAIL  
for a FREE 96 page catalog.  
Outside the U.S.A. send \$3.00 postage.

## MINI-STEREO AUDIO AMPLIFIER W/ SPEAKERS

Miniature 4W (2 x 2W) stereo amplifier with speakers and battery holder. 3.5mm stereo phone plug input connects to many portable audio sources, MP3s, iPods etc. The on-off switch and volume control are in a 34mm square module attached to the amplifier with a 29" flat cable. The speakers included with the amp are an interesting pair of 1.30" x 1.45" x 0.36" flat-panel speakers incorporating a unique cone-less technology. We don't know for what application these speakers are intended; they might be better for voice or sound effects, but the amplifier sounds a lot better with traditional 4 Ohm cone-type speakers. Operates on 4 AA batteries, not included.  
**CAT# AMP-5** **\$8.50 each**

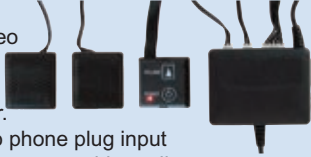

## 3 1/2 DIGIT LCD MULTI-METER W/ BACKLIGHT

Velleman # DVM850BL. For features, accuracy and ruggedness, this is the best inexpensive multimeter we've ever seen. DC current (10 A), DC and AC voltage (600 V), resistance (2 M ohm), diode, transistor tester, audible continuity and hold button. Protective rubber shell and test leads included.  
**CAT# DVM-850BL** **\$17.95 each**



## VIBRATING MINI-MOTOR

Designed to vibrate in cell phones or pagers, this tiny 1.5-4.5Vdc motor has an offset weighted shaft. Overall length, including terminals and shaft, 18mm. Body is 4.5mm x 5.5mm x 11mm long. Flat, surface-mount solder tabs.  
**CAT# DCM-382** **\$1.25 each**



10 for \$1.10 each • 100 for 95¢ each

## 21MM PIEZO ELEMENT

50mm wire leads.  
**CAT# PE-56**



**\$1.00 each**

10 for 85¢ each

## 40 CHARACTER X 2 LINE LCD W/ LED BACKLIGHT

#UMSH-3077JD-YG. STN Transflective LCD. Yellow-green LED backlight. Module size: 182 x 33.5 x 13.6mm. Viewing area: 154.4 x 16.5mm. Character size: 3.2 x 5.55mm.  
**CAT# LCD-3077** **\$8.50 each**

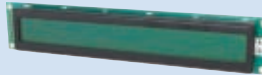

10 for \$7.50 each

## SOLDERABLE PERF BOARD

Line pattern. 1mm holes on 0.1" grid. 100 X 80 mm single-sided epoxy board.  
**CAT# ECS-6** **\$3.50 each**

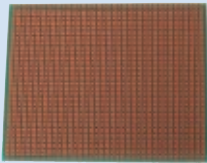

## PRECISION DC GEAR MOTOR, USED

FAULHABER #1624E024SNP305. Small, powerful-for-its-size, very-low current, Swiss made gear motor. No-load Ratings: 320 RPM @ 12Vdc/ 2.5mA. 545 RPM @ 20Vdc / 3.9mA. 17mm diameter x 40mm long overall. 2mm diameter x 10mm shaft with attached 11.7mm diameter pulley for round, 2mm belt. Motor face has 4 tapped mounting holes. Two wire leads, 45mm. Used, removed from equipment in good condition.  
**CAT# DCM-705** **\$8.85 each**

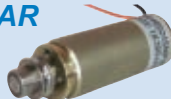

## 250K AUDIO POT W/ SWITCH

250K Ohm, audio taper potentiometer with DPDT, push-pull switch. 6mm knurled, split shaft. 8mm diameter threaded bushing is 13mm long. New pots - prepped with wires and a 9V battery snap.  
**CAT# ATPS-250K** **\$1.00 each**



## 12 VDC FLASH ASSEMBLY

Bright xenon strobe assembly with horseshoe flash tube. Approximately 80 flashes per minute. 65 x 75mm PC board. 12 Vdc operation.  
**CAT# FSH-13** **\$7.00 each**



## BREADBOARD, 840 CONTACTS

Breadboards accommodate all sizes of dips and discrete components. Interconnect with solid hook-up wire (#22 AWG recommended). Wires and components can be used and re-used many times without damage to board or components. Dual row of buss terminals on each side of terminal strip.  
**CAT# PB-840** **\$7.65 each**



Shop ON-LINE [www.allelectronics.com](http://www.allelectronics.com)  
ORDER TOLL FREE 1-800-826-5432

MAIL ORDERS TO:  
ALL ELECTRONICS CORP.  
14928 OXNARD ST., VAN NUYS, CA 91411-2610

FAX (818) 781-2653 • INFO (818) 904-0524  
E-MAIL [allcorp@allcorp.com](mailto:allcorp@allcorp.com)



NO MINIMUM ORDER • All Orders Can Be Charged to Visa, Mastercard, American Express or Discover • Checks and Money Orders Accepted by Mail • Orders Delivered in the State of California must include California State Sales Tax • NO C.O.D • Shipping and Handling \$7.00 for the 48 Continental United States - ALL OTHERS including Alaska, Hawaii, P.R. and Canada Must Pay Full Shipping • Quantities Limited • Prices Subject to change without notice.

MANUFACTURERS - We Purchase EXCESS INVENTORIES... Call, Write, E-MAIL or Fax YOUR LIST.



## Programmable DC Electronic Load 0~80V / 0~40A



The 3721A Programmable DC Electronic Load provides excellent performance with sophisticated features found on much more expensive units. This 400 watt, 40 Amp, 0~80 volt Programmable DC Electric Load can be used to test all sorts of DC power sources including power supplies and is especially helpful to battery manufacturing processes. This DC load features constant voltage, constant resistance, constant current and constant power settings. The end user can design programs that control precisely all of the load values and time durations for each step of a test sequence. Up to nine 10 step programs can be internally stored in the 3721A Programmable DC Load.

4 basic functions: CC, CV, CR & CP

8 basic test modes: CCL, CCH, CV, CRL, CRM, CRH, CPV & CPC

Minimum operating voltage is less than 0.6v at the load's full rated current.

High-speed sequence, high-speed transient, short circuit, battery discharge and other functions.

Programmable current slew rate.

Multiple groups of parameters and lists can be saved & recalled.

Supports SCPI and LabView with included software.

Current Rating: 0~40A

Voltage Rating: 0~80V

Power Rating: 400W at 40°C

Item#

**CSI3721A**

**\$720.00**

[www.CircuitSpecialists.com/CSI3721A](http://www.CircuitSpecialists.com/CSI3721A)

## Programmable DC Electronic Loads



These devices can be used with supplies up to 360VDC and 30A. It features a rotary selection switch and a numeric keypad used to input the maximum voltage, current and power settings. These electronic DC loads are perfect for use in laboratory environments and schools, or for testing DC power supplies or high-capacity batteries. It also features memory, and can also be connected to a PC, to implement remote control and supervision.

**360V/150W (CSI3710A) \$349.00**

[www.circuitspecialists.com/csi3710a](http://www.circuitspecialists.com/csi3710a)

**360V/300W (CSI3711A) \$499.00**

[www.circuitspecialists.com/csi3711a](http://www.circuitspecialists.com/csi3711a)

## Huge Stepper Motor and Controller Sale!

Circuit Specialists carries a large selection of stepper motors and controllers



**42BYGH207**

NEMA 17

3.0 kg.cm Torque

**\$10.95 ea.** reg. \$14.90



**57BYGH207**

NEMA 23

8.0kg.cm / 111 oz.in Torque

**\$13.95 ea.** reg. \$19.50



**57BYGH405A**

NEMA 23

20 kg.cm / 277 oz.in Torque

**\$22.50 ea.** reg. \$27.50



**85BYGH450C-03**

NEMA 34

63 kg.cm / 870 oz.in Torque

**\$69.50 ea.** reg. \$89.00



**XCW-220**

2 Phase Microstepping Stepper Motor Driver for our 42 & 57 series stepper motors.

**\$29.50 ea.** reg. \$39.95



**CW250**

2 Phase Microstepping Stepper Motor Driver for our 57 & 85 series stepper motors.

**\$42.00 ea.** reg. \$54.95



**42BYGH404**

NEMA 17

3.4 kg.cm / 47 oz.in Torque

**\$10.95 ea.** reg. \$14.90



**57BYGH303**

NEMA 23

15 kg.cm / 208 oz.in Torque

**\$19.95 ea.** reg. \$23.95



**85BYGH450B-03**

NEMA 34

48 kg.cm / 665 oz.in Torque

**\$49.50 ea.** reg. \$68.00



**QJ-215**

Microstepping Stepper Motor Driver for our 42 Series Stepper Motors.

**\$42.00 ea.** reg. \$54.90



**CW230**

2 Phase Microstepping Stepper Motor Driver for our 42 & 57 series stepper motors.

**\$39.50 ea.** reg. \$48.50



**CW860**

2 Phase Microstepping Stepper Motor Driver for our 57 & 85 series stepper motors.

**\$79.00 ea.** reg. \$96.00

[www.CircuitSpecialists.com/stepper-motors-and-controllers](http://www.CircuitSpecialists.com/stepper-motors-and-controllers)

## 60 Watt Digital Soldering Station

For use with traditional or Lead Free Soldering



Features:

- \* 60 watt dual core ceramic heater
- \* 150 to 450 degree Celsius Temperature range
- \* Versatile easy to read liquid crystal display
- \* 3 preset & user definable temperature settings.
- \* Automatically remembers previous temperature setting
- \* Display in Celsius or Fahrenheit scale
- \* 3 foot cord length from station to iron tip
- \* Broad selection of replacement tips available

This is a terrific soldering station featuring a microprocessor controlled temperature set up system with great versatility. The unit includes 3 preset temperature settings that are user definable so you can turn on the system & push one button to go to the temperature range you desire. Specific system temps can also be set with an easy to use push button up/down button AND when you turn off this station, the unit keeps the last used temperature in memory & automatically returns to that setting the next time the user turns the system on. The temperature display can be set to display in Celsius or Fahrenheit scale.

The CSI-Station-3DLF is a powerful 60 watt soldering system. The fast heat recovery provided by a 60 watt system like this allows the user to solder both traditional solder and lead free solder. This system features a grounded tip to protect delicate circuits from static charge. Also included is a separate iron holder. Circuit Specialists stocks a large supply of tips for this station.

Item#

**CSI-Station-3DLF**

**\$49.00**

[www.CircuitSpecialists.com/CSI-Station-3DLF](http://www.CircuitSpecialists.com/CSI-Station-3DLF)

Circuit Specialists carries a wide selection of traditional & lead-free soldering equipment, including soldering irons, soldering stations, hot-air rework stations, focused infrared systems, reflow ovens, pre-heating systems, regular and lead-free solder, solder flux, and soldering aids for both thru-hole and surface-mount soldering.

See our complete line of soldering equipment at:

[www.CircuitSpecialists.com/soldering-equipment](http://www.CircuitSpecialists.com/soldering-equipment)





We carry a LARGE selection of Power Supplies, Soldering Equipment, Test Equipment, Oscilloscopes, Digital Multimeters, Electronic Components, Metal and Plastic Project Boxes, Electronic Chemicals, PC Based Digital I/O Cards, Panel Meters, Breadboards, Device Programmers, and many other interesting items. Check out our website at:

[www.CircuitSpecialists.com](http://www.CircuitSpecialists.com)

## Best Value, Low Cost Station CSI-Station1A



Easily our best value in our selection of soldering stations. O.E.M. manufactured just for Circuit Specialists Inc., so we can offer the best price possible! The CSI-Station1A features a grounded tip & barrel for soldering static-sensitive devices and uses a ceramic heating element for fast heat up & stable temperature control.

The control knob is calibrated in Fahrenheit & Celsius (392° to 896°F and 200° to 480°C). One of the nicest features is the high quality comfort grip soldering iron. The iron connects to the station via an easy screw-on connector making iron replacement a snap. The 1 meter length iron cord provides plenty of length for users to set up the station in a convenient location. Another nice feature is the soldering iron holder. Made of rugged aluminum, it is a separate piece from the main station & allows the user maximum convenience....you don't have to reach all the way back to the station to store the iron. Yet another feature is the stackable design of the CSI-Station1. The main station is designed for an additional unit to be placed on top of it allowing for space saving placement of the CSI-Station1A. Also included at no additional charge is one user replaceable ceramic heating element so that you will be prepared! Large selection of soldering tips available too.

Item #

**CSI-STATION1A**

**\$29.95**

[www.circuitspecialists.com/csi-station1a](http://www.circuitspecialists.com/csi-station1a)

## 3 Channel Programmable Regulated DC Power Supplies



Check out our new programmable hi performance 3 channel power supplies. Featuring both USB & RS232 interfaces, Overload Protection, Auto Fan Control, and Series or Parallel Operation. Both units feature a Large LCD display panel with simultaneous output and parameter view and a keypad for control. They are ideal for applications requiring high resolution, multiple output, and automated operation such as in production testing. There are both fine and coarse controls via the shuttle knob and 90 memory settings. Software included.

**CSIPPS33T** 0~32V / 0~3A **\$299.00**

[www.CircuitSpecialists.com/CSIPPS33T](http://www.CircuitSpecialists.com/CSIPPS33T)

**CSIPPS55T** 0~32V / 0~5A **\$379.00**

[www.CircuitSpecialists.com/CSIPPS55T](http://www.CircuitSpecialists.com/CSIPPS55T)

## 200MHz Hand Held Scopemeter with Oscilloscope & DMM Functions

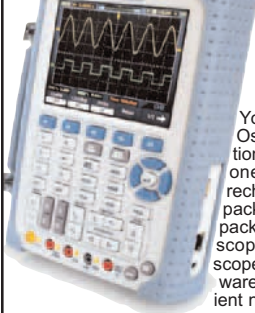

Includes  
1 Year USA  
Warranty

You get both a 200 MHz Oscilloscope and a multi function digital multimeter, all in one convenient lightweight rechargeable battery powered package. This power packed package comes complete with scopemeter, test leads, two scope probes, charger, PC software, USB cable and a convenient nylon carrying case.

- 200MHz Handheld Digital Scopemeter with integrated Digital Multimeter Support
- 200MHz Bandwidth with 2 Channels
- 500MSa/s Real-Time Sampling Rate
- 50Gsa/s Equivalent-Time Sampling Rate
- 6,000-Count DMM resolution with AC/DC at 600V/800V, 10A
- Large 5.7 inch TFT Color LCD Display
- USB Host/Device 2.0 full-speed interface connectivity
- Multi Language Support
- Battery Power Operation (Installed)

Item # **DSO1200** New Low Price! **\$589.00**

[www.circuitspecialists.com/DSO1200](http://www.circuitspecialists.com/DSO1200)

## 60MHz Hand Held Scopemeter with Oscilloscope & DMM Functions

- 60MHz Handheld Digital Scopemeter with integrated Digital Multimeter Support
- 60MHz Bandwidth with 2 Channels
- 150MSa/s Real-Time Sampling Rate
- 50Gsa/s Equivalent-Time Sampling Rate
- 6,000-Count DMM resolution with AC/DC at 600V/800V, 10A
- Large 5.7 inch TFT Color LCD Display
- USB Host/Device 2.0 full-speed interface connectivity
- Multi Language Support
- Battery Power Operation (Installed)



Item # **DSO1060** New Low Price! **\$429.00**

[www.circuitspecialists.com/DSO1200](http://www.circuitspecialists.com/DSO1200)

## 60MHz Hand Held Scopemeter w/Oscilloscope, DMM Functions & 25 MHz Arbitrary Waveform Generator

- All the features of the DSO1060 plus a 25 MHz Arbitrary Waveform Generator.
- Waveforms can be saved in the following formats: jpg/bmp graphic file, MS excel/word file
- Can record and save 1000 waveforms
- DC to 25 MHz Arbitrary Waveform Generator



Item # **DSO-8060** New Low Price! **\$519.00**

[www.circuitspecialists.com/DSO-8060](http://www.circuitspecialists.com/DSO-8060)

## Programmable DC Power Supplies

- Up to 10 settings stored in memory
- Optional RS-232, USB, RS-485 adapters
- May be used in series or parallel modes with additional supplies.
- Low output ripple & noise
- LCD display with backlight
- High resolution at 1mV



Model	CSI3644A	CSI3645A	CSI3646A
DC Voltage	0-18V	0-36V	0-72V
DC Current	5A	3A	1.5A
Power (max)	90W	108W	108W
Price	<b>\$199.00</b>	<b>\$199.00</b>	<b>\$199.00</b>

[www.CircuitSpecialists.com/inspection-cameras](http://www.CircuitSpecialists.com/inspection-cameras)

Ideal for Law Enforcement,  
Post Fire Inspection, Plumbing,  
Facilities Maintenance,  
Security Companies,  
& Many Other Uses!

## Aardvark II

Dual Camera  
Wireless Inspection Camera  
With Color 3.5" LCD  
Recordable Monitor  
Your Extended Eyes & Hands!



**See It!**  
Clearly in narrow spots, even in total darkness or underwater.  
**Find It!**  
Fast. No more struggling with a mirror & flash light.  
**Solve It!**  
Easily, speed up the solution with extended accessories.  
**Record It!**  
With the 3.5" LCD recordable monitor, you can capture pictures or record video for documentation.

The Aardvark Wireless Inspection Camera is the only dual camera video borescope on the market today. With both a 17mm camera head that includes three attachable accessories and a 9mm camera head for tighter locations. Both cameras are mounted on 3ft flexible shafts. The flexible shaft makes the Aardvark great for inspecting hard to reach or confined areas like sink drains, AC Vents, engine compartments or anywhere space is limited. The Aardvark II comes with with a 3.5 inch color LCD monitor. The monitor is wireless and may be separated from the main unit for ease of operation. Still pictures or video can also be recorded and stored on a 2GB MicroSD card (included). The Aardvark's monitor also has connections for composite video output for a larger monitor/recorder and USB interface for computer connection. Also included is an AC adapter/charger, video cable and USB cable. Optional 3 ft flexible extensions are available to extend the Aardvark's reach (Up to 5 may be added for a total reach of 18 feet!).

Item #

**AARDVARK II**

**\$199.00**

[www.CircuitSpecialists.com/aardvark-ii](http://www.CircuitSpecialists.com/aardvark-ii)



## Aardvark Nine

9mm Wireless Inspection Camera  
With Color 3.5" LCD Recordable  
Monitor  
Your Extended Eyes & Hands!

Same great Aardvark Wireless Inspection Camera System, but with only the 9mm Camera for a lower cost option!

Item #

**AARDVARK NINE**

**\$149.00**

[www.CircuitSpecialists.com/aardvark-nine](http://www.CircuitSpecialists.com/aardvark-nine)



## Aardvark Jr

9mm Wireless Inspection Camera  
With Color LCD Monitor  
With its small 9mm camera head, the Aardvark Jr allows for easy visual inspection in hard-to-reach areas. Lightweight, handheld design to easily find, diagnose and solve problems with the flexible extended tube and useful accessories.

Item #

**AARDVARK JR**

**\$79.00**

[www.CircuitSpecialists.com/aardvark-jr](http://www.CircuitSpecialists.com/aardvark-jr)



# LI-ION Power Pack/Charger

The Li-ion Power Pack/Charger is an integrated storage cell and charging system on a 3" x 4" printed circuit board and is compatible with most 18650-size Li-ion cells. This board is a great solution for any application needing a reliable power supply with an integrated charging system. Works well with most microcontrollers.

## APPLICATION IDEAS:

- Portable power for data-logging applications
- Mobile robots
- Standby power / automatic power-switching
- Automatic charging circuits
- Stackable auxiliary power solutions



### Li-ion Power Pack/Charger – 2 Cell (#28986; 49.99)

Includes 3 x 4" PCB with integrated charging circuitry, battery cable, and an extra fuse (Li-ion cells not included).

### High-Capacity Li-ion Cells (#28987; \$7.99 each)

### 7.5 V, 1 A Power Supply (#750-00009; \$9.99 each)



## FEATURES:

- Nominal 7.4 VDC output; 8.2 VDC maximum
- Charging time of 1-6 hrs or more, depending upon the discharge level and capacity of the battery.
- Recharge with a 7.5 V, 1 A center-positive power supply
- Multiple power input/output options
- On-board output fuse protection
- Automatic charge/discharge switching circuitry
- Holds two rechargeable 3.7 volt Li-ion 18650-size cells
- Multiple LED indicators provide charge readiness information for each individual cell; status key for the LED indicators is printed on the board.
- Aggressive holders retain cells in any board orientation and in moderate shock environments, such as mobile robotic applications. Cells are not permanent, and are easily replaced.
- Dedicated circuitry continuously monitors the charging process to ensure safety, efficiency, and to maximize the number of charge/discharge cycles of each cell.

Order a **Li-ion Power Pack/Charger and cells** at [www.parallax.com](http://www.parallax.com) or call our Sales Department toll-free at 888-512-1024 (M-F, 7AM-5PM, PDT).

**Friendly microcontrollers, legendary resources.™**

Prices subject to change without notice. Parallax and the Parallax logo are trademarks of Parallax Inc.

# PARALLAX

[www.parallax.com](http://www.parallax.com)



"ParallaxInc" on Twitter, Facebook, and YouTube