

NUTS & VOLTS

NUTS AND VOLTS

www.nutsvolts.com
October 2011

EVERYTHING FOR ELECTRONICS

Live Action

Flasher, Gate, And Bell

For Your Model Railroad

*Legacy
Communication
With The
32-Bit Micro
Experimenter*

◆ Meet the new
**PICAXE M2-Class
microcontrollers**

◆ Web browser
control of your
home thermostat

◆ Whatever happened
to **CB radio?**

This season, try an LED Christmas Tree
as your table centerpiece.



U.S. \$6.50 CANADA \$7.50



CROSSING
SIGNAL

The easiest finished product you will ever create

Start with the PK70 EX



Design your own, or use a
NetBurner Personality Blade



Add your label to get a
finished product



Personality Blades

Prototype Blade (P/N NBPBKP-100CR)..... \$25 ea.
Create your own Personality Blade

CPLD Digital I/O Blade (P/N NBPKD-100CR)..... \$59 ea.
Programmable Xilinx CPLD
32 digital I/O

Multi-I/O Blade (P/N NBPKM-100CR) \$99 ea.
Eight 12-bit analog-to-digital inputs
Two 16-bit digital-to-analog outputs
16 digital I/O

FPGA Digital I/O Blade (P/N NBPKX500-100CR) \$169 ea.
Programmable Xilinx Spartan 3E FPGA
High-density 62-pin connector

NTP Server with GPS Blade (P/N NBPKX500-100CR) \$99 ea.
Network Time Protocol (NTP) server
Precision GPS time reference

Quad UART Blade: RS-232 Version
(P/N NBPKBU-232CR)..... \$99 ea.
Network enable up to 4 RS-232 serial devices

Quad UART Blade: RS-422/485 Version
(P/N NBPKBU-485CR)..... \$119 ea.
Network enable up to 4 RS-422/485 serial devices

Quad UART Blade: RS-232/422/485 Version
(P/N NBPKBU-MMSCR) \$245 ea.
Network enable up to 4 RS-232/422/485 serial devices

PK70 EX & Development Kit

PK70 EX (P/N PK70EX-100IR) \$199 ea.
32-Bit Freescale ColdFire 147 MHz CPU
8MB SDRAM • 4MB Flash Memory
SD/MMC Flash Card Support • I2C • SPI • Address and Data Bus
10/100 Ethernet • 2 UARTs

PK70 EX Development Kit
(P/N NNDK-PK70EX-KIT) \$299 ea.
The Development Kit features NetBurner's Eclipse, an enterprise level professional IDE that provides editing, downloading and debugging in one environment.



the best place for microcontroller community projects and libraries



LIBSTOCK[®]

A PLACE FOR CODE[™]

DOWNLOAD FREE PROJECTS AND LIBS

Get all kinds of cool ideas. Download free, functional and working libraries and projects, including schematics, documents and tutorials, and install them with a single click. Everything you need is in one place.

SHARE YOUR CODE WITH THE COMMUNITY

Do you want to share your work with the rest of the world, and get community feedback on your projects? This website gives you the best infrastructure a programmer can have for sharing the code.

IT'S A FACEBOOK FOR CODERS

With personalized accounts, you can connect with other programmers, share experiences, and learn more about yourself too. Social interaction brings a new dimension to the world of programming.



ALL COMPILERS SUPPORTED

mikroC, mikroBasic and mikroPascal for PIC, dsPIC, PIC32, AVR and 8051 are all natively supported by Libstock.

PACKAGE MANAGER SOFTWARE

With free Package Manager software, you can make one-click extractable packages of your libraries and projects.

EXCLUSIVE MIKROE LIBRARIES

TCP/IP stack, FAT16 and FAT32 are just part of the libraries that mikroElektronika will exclusively share only on Libstock website.

BitScope

Digital + Analog

100 MHz Digital Oscilloscope

- ✓ Dual Channel Digital Storage Oscilloscope with up to 12 bit analog sample resolution and high speed real-time waveform display.

40 MSPS x 8 Channel Logic Analyzer

- ✓ Captures eight logic/timing signals together with sophisticated cross-triggers for precise multi-channel mixed signal measurements.

Serial Logic and Protocol Analyzer

- ✓ Capture and analyze SPI, CAN, I2C, UART & logic timing concurrently with analog. Solve complex system control problems with ease.

Real-Time Spectrum Analyzer

- ✓ Display analog waveforms and their spectra simultaneously in real-time. Baseband or RF signals with variable bandwidth control.

Waveform and Logic Generators

- ✓ Generate an arbitrary waveform and capture analog & digital signals concurrently or create programmable logic and/or protocol patterns.

Multi-Channel Chart Recorder

- ✓ Record to disk anything BitScope can capture. Allows off-line replay and waveform analysis. Export captured waveforms and logic signals.

Everything in one tiny package !



BitScope Pocket Analyzer is the world's first Mixed Signal Scope to include a powerful Logic Protocol Analyzer, Waveform & Pattern Generator, Spectrum Analyzer and Chart Recorder in one ultra-portable **USB powered** package.

Pocket Analyzer is fast, displaying up to 100 frames per second with up to 12kS per frame. Alternatively stream data direct to disk for replay and analysis.

Compatible with major operating systems including Windows, Linux & Mac OS X, Pocket Analyzer is your ideal test and measurement companion.

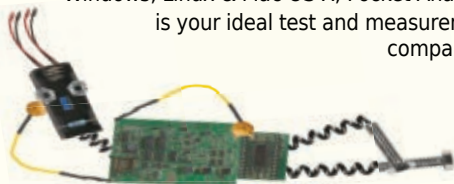

Mixed Signal Oscilloscopes



Pocket Analyzer



Protocol Analyzer



Digital Oscilloscope

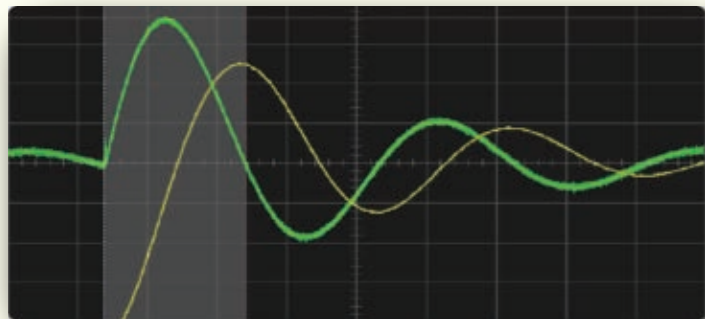

Spectrum Analyzer

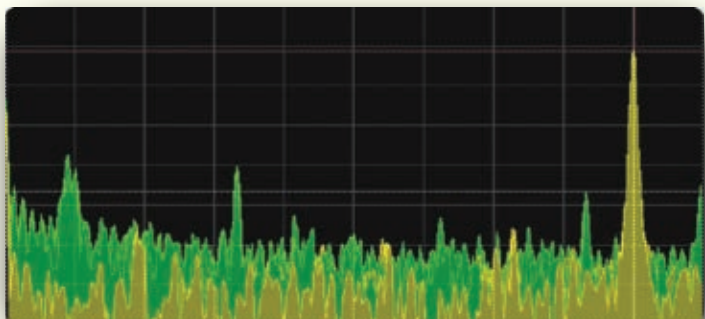

bitscope.com/nv

DIY Projects:

Simple Tracked Robot

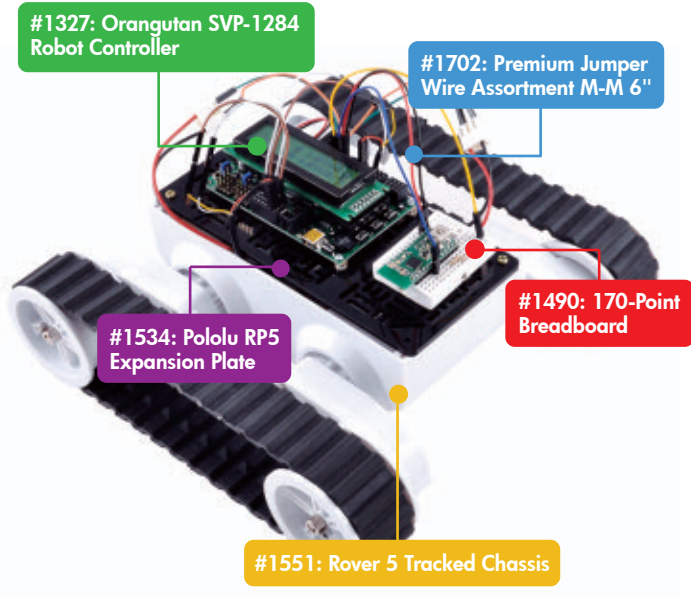

Robots and Robot Kits:

Pololu 3pi and m3pi

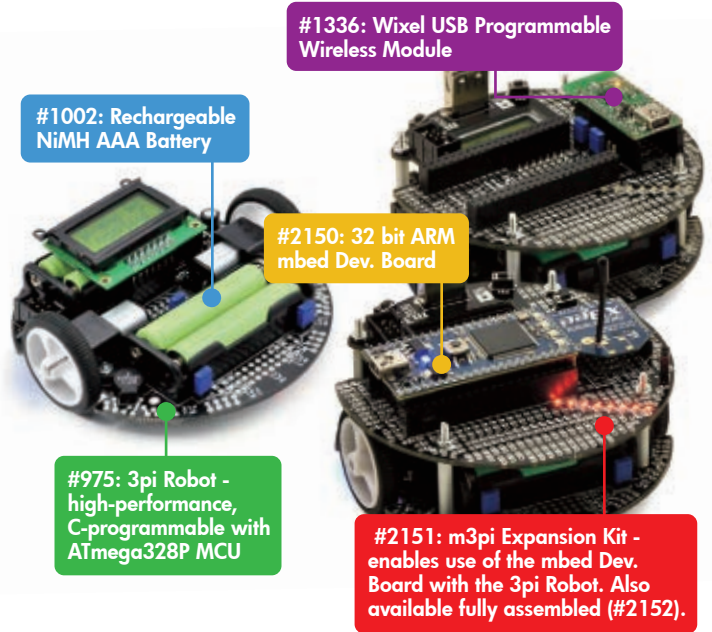

Programmable Controllers:

Wixel and Wixel Shield

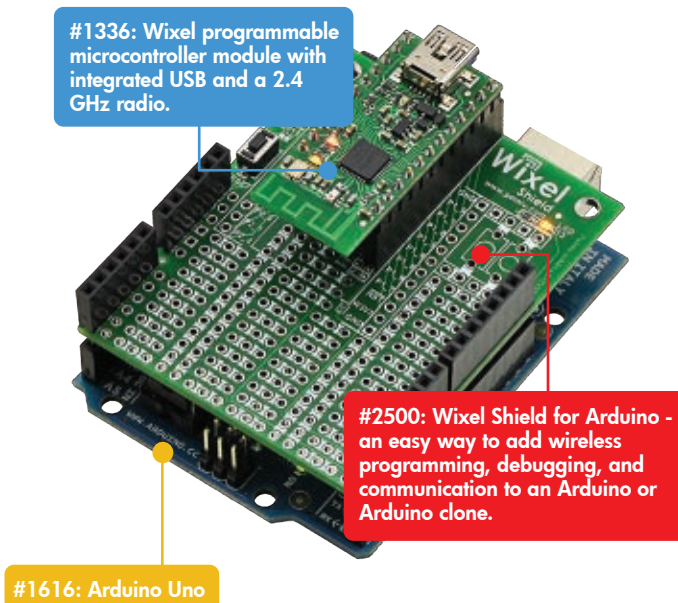

Hobby/RC Servo Controllers:

Micro and Mini Maestros

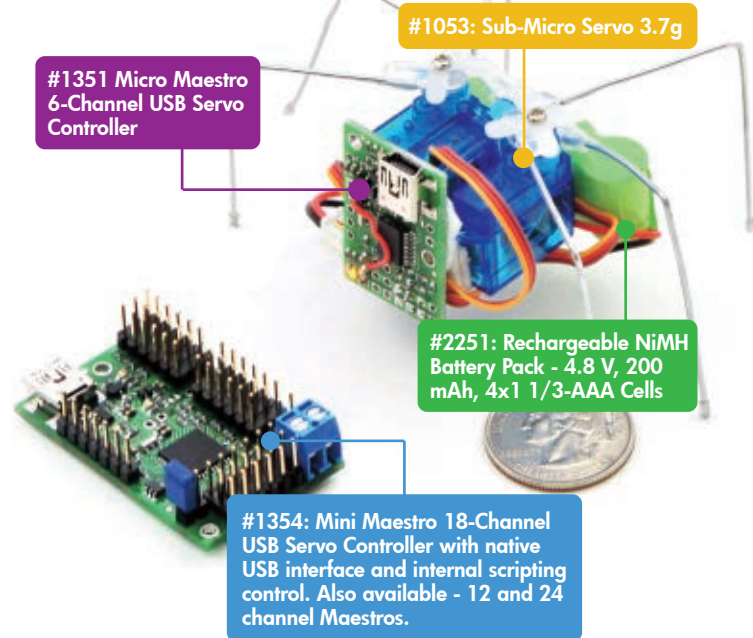

Finding the right parts for your robot can be difficult, but you also don't want to spend all your time reinventing the wheel (or motor controller). That's where we come in: Pololu has the unique products - from actuators to wireless modules - that can help you take your robot from idea to reality.



Columns

- 10 TechKnowledgey 2011**
Events, Advances, and News
This month's column covers memory going soft, speedier graphics cards, a studio in your shirt pocket, plus some other cool stuff.
- 14 PICAXE Primer**
Sharpening Your Tools of Creativity
Introducing the new PICAXE M2-Class microcontrollers.
- 22 Q & A**
Reader Questions Answered Here
Get answers about gel cell charging voltages, a VFD filament driver, relay logic, and more.
- 56 The Design Cycle**
Advanced Techniques for Design Engineers
Invasion of the chipKIT Max32.
- 64 Open Communication**
The Latest in Networking and Wireless Technologies
Whatever happened to CB radio?
- 68 Smiley's Workshop**
Programming • Hardware • Projects
Digital I/O — Part 1.

Projects & Features

- 30 Web Browser Control of Your Home Thermostat — Part 2**
In this final installment, the physical connections, some construction details, and the software that makes the unit work will be described.
■ By Jürgen G. Schmidt
- 36 Build the LED Centerpiece Christmas Tree**
Brighten the holidays with this colorful decoration that can be a table centerpiece or be modified for an outside display.
■ By Larry W. Jackson
- 42 A Flasher, Gate, and Bell for Your Model Railroad**
This simple PIC circuit will enhance your railroad display with live action and a realistic bell sound.
■ By Loren Blaney
- 50 Legacy Communication With the 32-Bit Micro Experimenter**
This article explores the use of legacy communication that exists between the Experimenter (as a terminal) and a PC.
■ By Thomas Kibalo

You Asked and We Listened — New Forums are ONLINE!

This issue marks the first time that *Nuts & Volts* content will be directly linked to our online presence! We have completely rearchitected the forums so they now closely reflect the content of the magazine. Every regular column now has its own dedicated forum with the column author as your host! In addition, there are also forums to support project articles for reader projects and even an area where you can learn about what it takes to become a writer for the magazine! This new forum design invites you to interact with the author(s), read about corrections or modifications to projects, post questions, or just find and interface with lots of other folks who enjoy the same things you do. As an added bonus, we have populated the forums with example articles by each author so you can read them there if you don't have time to read them here. We hope you find the new forum layout exciting and useful. Please come by, have a look around, and introduce yourself! To explore the new forums, just point your browser to:

<http://forum.servomagazine.com>.

Hope to see you online soon! :)

Vern Graner, Forum Moderator, *Nuts & Volts*

Departments

08	DEVELOPING PERSPECTIVES	74	CLASSIFIEDS
27	SHOWCASE	75	NV WEBSTORE
28	NEW PRODUCTS	78	TECH FORUM
67	ELECTRO-NET	80	AD INDEX

Innovative Trainers



Digital Logic Trainer & Analog Circuit Trainer

The **DL-020 Sequential Logic Trainer** introduces concepts of sequential logic design, which is the final basic elements to understanding microprocessor and microcontroller logic. The **PB-502 Advanced Logic Design Trainer** is a portable robust instrument capable of satisfying many requirements arising in the design and study of digital logic circuitry.



Transparent Breadboards

The transparent solderless breadboards are perfect for educational applications by allowing student and designers to clearly view circuit connections. The solderless breadboards can be used to experiment and design a multitude of analog and digital circuits, as well as test fixture and prototyping applications.



Courseware

Global Specialties offers many options to aid in electronics course and lab instruction. Comprehensive courses in electronics fundamentals, digital logic, and digital electronics are available for Global's most popular circuit trainers



Digital Multimeter Pro-50A



Model **PRO-50A** is a highly versatile, economically-priced, hand-held digital multimeter. The New Model PRO-50A's versatility & multi-functional measuring capabilities makes it perfect for use by engineers, technicians, electricians and students.



by Bryan Bergeron, Editor

DEVELOPING PERSPECTIVES

Biology and Electronics

If you recall the experiment from your high school biology, Luigi Galvani found that electricity could animate the legs of a dead frog. This simple experiment is worth noting because the intersection of biology and electricity has come a long way since Galvani's experiments in 1791. Today, medical and physiological electronics are multi-billion dollar industries, and the tools for experimentation have never been as affordable or easily obtainable.

One of the easiest projects to start with is an electronic stethoscope. You can buy a commercial version on eBay for a few dollars if you're not looking for the thinnest, lightest model available. Or, you can build your own. You'll need an inexpensive, acoustic stethoscope head, a microphone element, and an audio amplifier. Once you've learned what your heart, lungs, and intestines sound like, you can use an analog-to-digital converter and your favorite microcontroller

to create a heart rate or breath rate display. Another option is to pick up and teardown an inexpensive blood pressure monitor from your local drug store. Can you figure out how they're determining pressure? You may have to search the Web for details, such as how the sound of blood flowing through arteries changes as external pressure is applied.

Then, there's the kit approach. I've seen several electrocardiogram (ECG) kits on the market. Ramsey (www.ramsey.com) sells one for about \$50. If you're familiar with op-amps, want a great way to learn how to work with op-amps and low level, low frequency signals, then build your own ECG monitor. I'd take the precaution of NEVER using an AC powered supply, even one of those low voltage bricks. In addition, use an optical isolator to minimize the chance that a voltage could be applied to your body as you're testing the circuit.

Of course, there are experiments you can perform in which signals are intentionally sent to your body, as in Galvani's experiment. Again, have a look on eBay for one of those abdominal toners that send pulses of electricity to your ab muscles, causing them to contract. At the other extreme – which I don't recommend – are high voltage tasers designed to temporarily stun.

If you're into exercising and fitness, then you probably know about the heart rate monitor pickups that work with Polar watches, and many of the treadmills on the market. This is another source of 'teardown' material that's relatively inexpensive – especially if you're willing to tear open one of the sealed sensors and replace a battery.

If you're into optics and LEDs, there are dozens of experiments that you can perform with an op-amp, microcontroller, LED, phototransistor, and a handful of discrete components. The simplest is a heart rate monitor based on the reflection or transmission of red light through your fingertip or earlobe. With each contraction of your heart, red blood cells rush through the capillaries in your fingertip. A phototransistor/op-amp circuit can detect the resulting change in transmission/reflection of red light. Once you've mastered heart rate, you can try your hand at blood oxygen saturation (the more oxygen carried by a red blood cell, the more red the cell). You'll have to do a little research to determine which wavelengths of light to use.

I've been working with a few simple sensors – a piezo microphone element and a few resistive pressure sensors – and an Arduino on a number of experiments. I use the piezo element in my shoe to determine each time my shoe strikes the ground – similar to the method used by the popular Apple/Nike running sensor. The pressure sensors – mounted at different locations under my running shoe insert

RF Specialists
Distributors of Low-Power RF modules, Zigbee, Bluetooth, WiFi, GPS, GSM/GPRS

ZigBee Solutions ProBee Series
High Performance and Robust Data Transfer Capability
ZigBee Solutions

**Low Cost
Low Power**

LEMOS INTERNATIONAL www.lemosint.com
866.345.3667
sales@lemosint.com

NUTS AND VOLTS

EVERYTHING FOR ELECTRONICS

Published Monthly By
T & L Publications, Inc.

430 Princeland Ct.
Corona, CA 92879-1300

(951) 371-8497

FAX (951) 371-3052

Webstore orders only **1-800-783-4624**

www.nutsvolts.com

Subscriptions

Toll Free **1-877-525-2539**

Outside US **1-818-487-4545**

P.O. Box 15277

North Hollywood, CA 91615

FOUNDER/ASSOCIATE PUBLISHER

Jack Lemieux

PUBLISHER

Larry Lemieux

publisher@nutsvolts.com

ASSOCIATE PUBLISHER/ VP OF SALES/MARKETING

Robin Lemieux

display@nutsvolts.com

EDITOR

Bryan Bergeron

techedit-nutsvolts@yahoo.com

CONTRIBUTING EDITORS

Jeff Eckert

Russ Kincaid

Joe Pardue

Fred Eady

Jürgen Schmidt

Loren Blaney

Larry Jackson

Ron Hackett

Louis Frenzel

Thomas Kibalo

CIRCULATION DIRECTOR

Tracy Kerley

subscribe@nutsvolts.com

SHOW COORDINATOR

Audrey Lemieux

MARKETING COORDINATOR

WEBSTORE

Brian Kirkpatrick

sales@nutsvolts.com

WEB CONTENT

Michael Kaudze

website@nutsvolts.com

ADMINISTRATIVE ASSISTANT

Debbie Stauffacher

PRODUCTION/GRAPHICS

Shannon Christensen

Copyright © 2011 by T & L Publications, Inc.

All Rights Reserved

All advertising is subject to publisher's approval. We are not responsible for mistakes, misprints, or typographical errors. *Nuts & Volts Magazine* assumes no responsibility for the availability or condition of advertised items or for the honesty of the advertiser. The publisher makes no claims for the legality of any item advertised in *Nuts & Volts*. This is the sole responsibility of the advertiser. Advertisers and their agencies agree to indemnify and protect the publisher from any and all claims, action, or expense arising from advertising placed in *Nuts & Volts*. Please send all editorial correspondence, UPS, overnight mail, and artwork to: **430 Princeland Court, Corona, CA 92879.**

Printed in the USA on SFI & FSC stock.  

– record the changes in pressure distribution as I run. My goal is to record changes in pressure distribution at different running paces. Runners at the Olympic Village use similar systems, but these sell for around \$50K. I've amassed most of my sensor collection from teardowns of devices I've picked up from Ebay. I've also purchased a few sensors from SparkFun Electronics and Parallax. Amazon is a convenient source for ECG electrodes, but you'll have to buy in bulk. If you want to experiment with a Polar heart rate monitor sensor strap, then consider the Polar interface from SparkFun. A Polar chest strap sensor is about \$50 on Amazon. As a final note, think about what you're doing. Electricity is potentially dangerous, in part because the salty fluid in your body is an excellent conductor. Don't use AC power and DC – at significant current – can burn. If you're not familiar with adhesive electrodes and other 'direct' connections, start out safe with optical sensors. Even then, consider that you could damage your eyes if you stare long enough into an active LED. Have fun on your journey. **NV**

WARNING: SPORTS ANALOGY AHEAD.

Think of XBee like a pitcher, throwing bits of wireless data to a catcher. Synapse is like a pitcher that has a giant mecha arm cannon that shoots data to robo t-rex catcher on a skateboard.

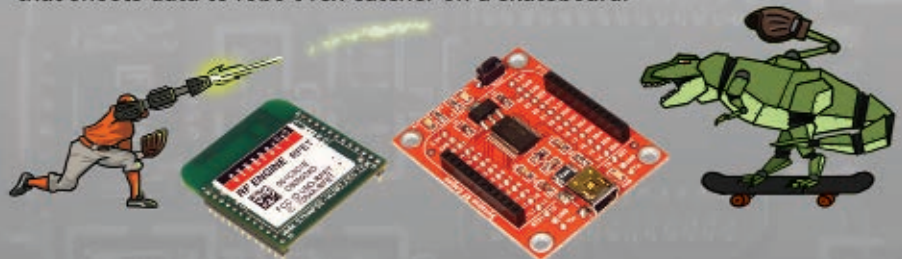

The Synapse Wireless communication system gives you more range, more I/O, and an easier python-based interface. Try them out for your next wireless project! (XBee adapters available too)

Learn more at: solarbotics.com/resources/projects/synapse/

 **SOLARBOTICS** Ltd

www.solarbotics.com

1-866-276-2687



P.S. - Synapse Wireless will TOTALLY help you score more basket point touchdown goals.



**MOTORS
GEARBOXES
WHEELS
AND MORE**

BB BaneBots BANEBOTS.COM
970-461-8880

■ BY JEFF ECKERT

ADVANCED TECHNOLOGY

SPLIT MAGNET SETS RECORD

At 25 tesla (T), it's not the absolute most powerful magnetic device ever built, but apparently it's top dog in the "split magnet" category, i.e., a magnet that is fabricated in two halves, with holes to allow the observation of experiments conducted at its core. Earlier this year, the custom-built, \$2.5 million system, located at the National High Magnetic Field Laboratory at Florida State University (www.magnet.fsu.edu), easily broke the previous record of 17.5 T, set by the French in 1991. In addition, it has 1,500 times as much room for experiments in its "bore," where four large, elliptical ports provide direct horizontal access to the central experimental space.

Building a magnet system with ports strong enough to withstand this physical stress was once considered physically impossible. After all, the structure has to withstand 500 tons of pressure pulling the two halves together while allowing 160,000 A of electrical current and 3,500 gallons of cooling water per minute to flow through it. However, through some innovative design work, extensive testing, and locating people who could actually build the thing, it was achieved. Not much specific information was provided about how the magnet will be employed, but it was revealed that "researchers in chemistry, physics, and biology are poised to conduct research using the split magnet, while others are optimistic about the potential for breakthroughs in nanoscience and semiconductor research."

The lab also holds the world's record for magnetic strength at 45 T, achieved by a hybrid (i.e., part resistive and part superconducting) device. The 11,000 sq ft lab houses a variety of research magnets, but only one or two can be operated at a time — the power system can handle only a measly 56 MW. Even so, the lab consumes seven percent of all the electricity used in its hometown of Tallahassee, FL. There's an open house at the lab every February, so check the website for the exact date if you expect to be in the neighborhood. ▲



■ Interior portion of the split coil magnet.

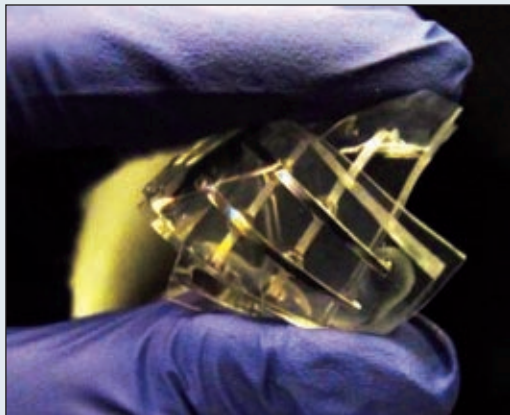

■ NCSU's soft memristor-type device functions in wet environments.

MEMORY GOING SOFT

For the most part, when your memory starts to go soft, it is not a good thing. Take my word for it. But researchers from North Carolina State University (www.ncsu.edu) have developed a memory device "with the physical properties of Jell-O" that seems to have some useful properties. Apparently, it functions well in wet environments which is "opening the door to a new generation of biocompatible electronic devices."

We're talking about a "memristor" type of device which — in the better-known Hewlett-Packard rendition — is composed of two layers of titanium dioxide connected by wire. In the NCSU version, the device is made using a liquid gallium/indium alloy set into a water-based gel. When you expose the alloy electrode to a positive charge, it creates an oxidized skin that resists the flow of electricity equivalent to a binary 0. When you expose it to a negative charge, it becomes conductive, giving us a 1. As explained in an NCSU press release, "Normally, whenever a

negative charge is applied to one side of the electrode, the positive charge would move to the other side and create another oxidized skin — meaning the electrode would always be resistive. To solve that problem, the researchers 'doped' one side of the gel slab with a polymer that prevents the formation of a stable oxidized skin. That way, one electrode is always conductive — giving the device the 1s and 0s it needs for electronic memory.

At this point, the device is just a prototype that admittedly is not yet capable of holding significant amounts of memory. However, because the gels used in the technology offer a high level of biocompatibility, it offers the promise of interfacing electronics directly with biological systems, e.g., living cells or tissues. ▲

COMPUTERS AND NETWORKING

SPEEDIER GRAPHICS CARD

If you're not a hard-core graphics user or serious gamer, the graphics card industry probably looks a little confusing. And, with a huge range of products with similar names coming from several manufacturers, it actually is. So, first a little history. Back in 2000, ATI Technologies (formerly Array Technologies, Inc.) began producing the Radeon line of graphics cards as a successor to its Rage products. In 2006, AMD (www.amd.com) acquired the company. However, AMD no longer manufactures the cards. Instead, it sells graphics processing units (GPUs) to third-party manufacturers who sell their own versions of AMD Radeon-branded products. Therefore, if you want to buy, let's say, an AMD Radeon HD 6950, it could actually be a product of one of about a dozen companies — even if you buy it through the AMD website. One of those companies is Sapphire Technology (not to be confused with Sapphire Technologies, an IT staffing group soon to be rebranded Randstad Technologies), and its latest contribution is the Sapphire HD 6950 Toxic Edition card. The company claims that it's the fastest production card in the class, based on clock speeds of 880 MHz for the core and 1,300 MHz (5.2 Gb/sec effective) for the memory. It also offers a dual BIOS feature that allows users to play around with alternative BIOS profiles and settings, and performance can be boosted with the company's TriXX overclocking tool (a free download). Using TriXX, you can modify memory and clock core speeds and voltages, and monitor the results. If you're interested in things like texture processing units and stream processors, you can get details at www.sapphiretech.com. As of this writing, price and availability are unknown, but earlier models sell for about \$275. ▲



■ Sapphire's HD 6950 Toxic Edition graphics card.

WIN \$200,000!

It's not all that unusual for software companies to pay "bug bounties" to people who find and fix vulnerabilities, but Microsoft has upped the ante. As announced at this year's Black Hat security conference, the company is sponsoring the \$250,000 BlueHat contest, created to "generate new ideas for defensive approaches to support computer security ... The object of this contest is to design a novel runtime mitigation technology solution that is capable of preventing the exploitation of memory safety vulnerabilities." First prize is \$200,000, second prize is \$50,000, and third prize is a Microsoft Developer Network (MSDN) Universal subscription, valued at \$10,000. All you have to do is design a runtime solution that can prevent the exploitation of memory safety vulnerabilities. Rules are available at www.microsoft.com/security/bluehatprize/. Just make sure your entry is received by April 1, 2012. ▲

DOWNLOAD YOUTUBE VIDEOS

If you have ever wondered if there is a sneaky way to download your favorite videos from YouTube, wonder no more. There are several ways, but the sneakiest is also the easiest. Just go to the URL window in your browser and add the word "kiss" after the "www." part. For example, let's say you're listening to Phil Keaggy doing a typically amazing guitar solo at www.youtube.com/watch?v=0T3to3DHLIE. Change "youtube" to "kissyoutube" and hit return. You'll be taken to saveyoutube.com and given several download options. Nothing to it. Just remember that if you do this too often, you're going to need a bigger hard drive. ▲

Custom Front Panels & Enclosures



FREE Software



Sample price \$57.32 + S&H

Designed by you using our FREE software, Front Panel Designer

- Cost effective prototypes and production runs
- Powder-coated finish and panel thickness up to 10mm now available
- Choose from aluminum, acrylic or customer provided material
- 1, 3 and 5-day lead times available

FRONT PANEL EXPRESS

FrontPanelExpress.com
(206) 768-0602

CIRCUITS AND DEVICES

CHIP OFFERS HDMI PROTECTION

The next generation of home entertainment systems will be able to offer improved signals, as well as protection against electrostatic discharge (ESD) strikes by incorporating a new IC from NXP Semiconductors (www.nxp.com). The company's IP4786CZ32 chip — said to be the industry's only complete HDMI 1.4 transmitter signal-conditioning and protection device — features a transmission line clamping architecture for reduced peak voltages during a strike plus impedance-matching inductors that provide matched 100-differential impedance through the device. By eliminating up to 29 discrete components, the IP4786CZ32 is claimed to offer the fewest components and a 60 percent smaller footprint compared to any other HDMI conditioning and protection scheme. The IC is compatible with HDMI 1.3a and 1.4, 340 MHz pixel clock, deep color, and HDMI Ethernet and Audio return Channel (HEAC). It's available now from NXP and distributors, with recommended pricing of \$1.20 in quantities of 1,000. ▲

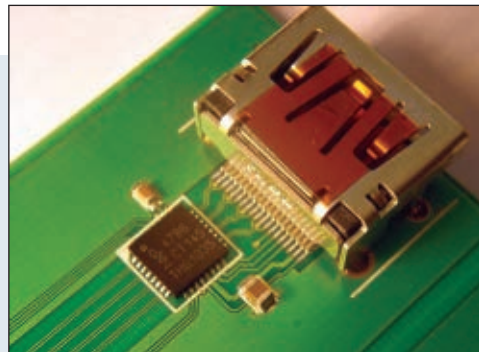

■ A new NXP chip offers both ESD protection and signal conditioning for HDMI signals.



■ Roland's Boss Micro BR-80 multi-track micro studio.

STUDIO IN YOUR SHIRT POCKET

Once upon a time, a multi-track recording studio was a huge and wondrous thing, filled with expensive mixing boards, monitor speakers, and recording machines with reels of magnetic tape the size of hubcaps. As you recorded your masterpieces, the reels would turn, needles on the VU meters would flip around, colored lights would flash, and Satan would dance around the room in a pink tutu. (Well, that last part may have been just a hallucination.) A lot has changed now, and you can get your own studio for a few hundred bucks and carry it around in your pocket. An example is the Boss Micro BR, model BR-80, a new eight-track micro studio from Roland (www.roland.com). It provides three recording modes: an eight-track MTR (multi-track recorder) mode, an "eBand" mode for onstage backing tracks and phrase training, and a "live rec" mode for making

instant stereo recordings via the built-in condenser mics. It records directly to an SD/SDHC memory card (up to 32 GB) and provides a user interface that basically follows a standard console layout, offering equalization, reverb, and a range of mastering tools. You even get a library of backing and rhythm patterns, and composite object sound modeling (COSM) amps and effects for guitar, bass, and vocals. It is, of course, USB connectable, so you can import and export files from a computer. Not bad for \$300. ▲

GO PLUCK YOURSELF

What happens if you get excited and buy the Boss BR-80 only to suddenly remember that you can't play guitar, don't want to put in a few thousand hours to learn, and don't have any musical aptitude in the first place? Not to worry! The lunatics at ThinkGeek (www.thinkgeek.com) have a solution: the Electronic Rock Guitar Shirt. Just put it on, place your finger in the right spot on the neck, and strum the string with one of the included magnetic picks. Out comes any of 15 power chords, recorded from a real electric guitar. The shirt includes a mini amp that clips onto your belt and features both a tone control and a volume knob that goes all the way up to 11. Not just 10, like your typical Marshall stack, but 11! All of the electronic components can be removed, so you'll have no trouble washing it after it becomes soaked with rancid Budweiser. For a demo by "L. Hadron and the Colliders," just log onto www.youtube.com/watch?v=V6JjY-AKPIY. And, yes, that's the Electronic Drum Kit Shirt on the other guy. Not shown is the Electronic Music Synthesizer Shirt. You can slip on any of them for \$29.99. Batteries not included, of course. **NV**



■ The Electronic Rock Guitar Shirt from ThinkGeek.

GREAT VALUE IN TEST & MEASUREMENT

Call for
educational
discount



70MHZ 2/4 CHANNEL DIGITAL OSCILLOSCOPE HMO 722/HMO724



from
\$1,773



100MHz:
HMO1022
HMO1024

- ✓ 2GSa/s Real time, low noise flash A/D converter (reference class)
- ✓ 2MPts memory, memory *Zoom* up to 50,000:1
- ✓ MSO (Mixed Signal Opt. HO 3508) with 8 logic channels
- ✓ Serial bus trigger and hardware accelerated decode, I²C, SPI, UART/RS-232 (Opt. H0010, H0011)
- ✓ Vertical sensitivity 1mV...5V/div. ✓ Lowest noise fan
- ✓ 12 div. x-axis display range
- 20 div. y-axis display range with VirtualScreen function
- ✓ Trigger modes: slope, video, pulsewidth, logic, delayed, event
- ✓ Component tester, 6 digit counter, Autoset, automeasurement, formula editor, ratiocursor, FFT for spectral analysis

1 GHz SPECTRUM ANALYZER HMS 1000/HMS 1010

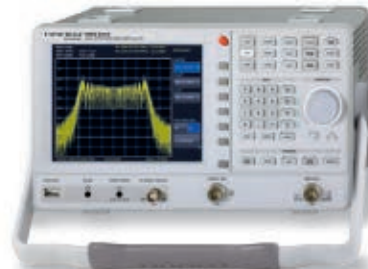

from
\$3,765

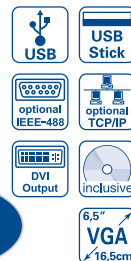

3GHz:
HMS3000
HMS3010

- ✓ Frequency range 100 kHz...1 GHz
- ✓ Amplitude measurement range -114...+20 dBm
- DANL -135dBm with Preamp. Option H03011
- ✓ Sweep time 20 ms...1000 s
- ✓ Resolution bandwidth 100 Hz...1 MHz in 1-3 steps, 200 kHz (-3 dB) additional 200 Hz, 9 kHz, 120 kHz, 1 MHz (-6 dB)
- ✓ Spectral purity < -100 dBc/Hz (@ 100 kHz)
- ✓ Video bandwidth 10 Hz...1 MHz in 1-3 steps
- ✓ Tracking Generator (HMS 1010) -20 dBm/0 dBm
- ✓ Integrated AM and FM demodulator (int. speaker)
- ✓ Detectors: Auto-, min-, max-peak, sample, RMS, quasi-peak

PROGR. 2/3/4 CHANNEL HIGH-PERFORMANCE POWER SUPPLY HMP SERIES



from
\$1,550

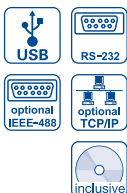

- ✓ HMP2020: 1x0...32V/0...10A 1x0...32V/0...5A, max. 188 W
- ✓ HMP2030: 3x0...32V/0...5A 188 W
- ✓ HMP4030: 3x0...32V/0...10A, max. 384 W
- ✓ HMP4040: 4x0...32V/0...10A, max. 384 W
- ✓ 188/384W output power realized by intelligent power management
- ✓ Low residual ripple: < 150 μV_{rms} due to linear post regulators
- ✓ High setting- and read-back resolution of up to 1mV/0.2mA
- ✓ HMP4030/HMP4040: Keypad for direct parameter entry
- ✓ Galvanically isolated, earth-free and short circuit protected output channels
- ✓ Advanced parallel- and serial operation via V/I tracking
- ✓ EasyArb function for free definable V/I characteristics
- ✓ FuseLink: individual channel combination of electronic fuses
- ✓ Free adjustable overvoltage protection (OVP) for all outputs
- ✓ All parameters clearly displayed via LCD/glowing buttons

25/50 MHZ ARBITRARY FUNCTION GENERATOR HMF2525/HMF2550



from
\$1,756

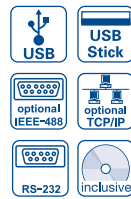

- ✓ Frequency range 10 μHz...25 MHz/50 MHz
- ✓ Output voltage 5mV_{pp}...10V_{pp} (into 50Ω) DC Offset ±5mV...5V
- ✓ Arbitrary waveform generator: 250 MSa/s, 14 Bit, 256 kPts
- ✓ Sine, Square, Pulse, Triangle, Ramp, Arbitrary waveforms incl. standard curves (white, pink noise etc.)
- ✓ Total harmonic distortion 0.04% (f < 100 kHz)
- ✓ Burst, Sweep, Gating, external Trigger
- ✓ Rise time < 8 ns, in pulse mode 8...500 ns variable-edge-time
- ✓ Pulse mode: Frequency range 100 μHz...12.5 MHz/25 MHz, pulse width 15 ns...999 s, resolution 5 ns
- ✓ Modulation modes AM, FM, PM, PWM, FSK (int. and ext.)
- ✓ 10 MHz Timebase: ± 1 ppm TCXO, rear I/O BNC connector
- ✓ Front USB connector: save and recall of waveforms and settings
- ✓ 3.5" TFT: crisp representation of the waveform and all parameters

LCR - BRIDGE HM8118



\$2,115

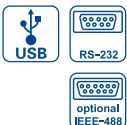

incl. **HZ188**

- ✓ Basic Accuracy 0.05%
- ✓ Measurement functions L, C, R, |Z|, X, |Y|, G, B, D, Θ, Δ, D, M, N
- ✓ Test frequencies 20 Hz...200 kHz
- ✓ Up to 12 measurements per second
- ✓ Parallel and Series Mode
- ✓ Binning Interface H0118 (optional) for automatic sorting of components
- ✓ Internal programmable voltage and current bias
- ✓ Transformer parameter measurement
- ✓ External capacitor bias up to 40V
- ✓ Kelvin cable and 4 wire SMD Test adapter included in delivery
- ✓ Galvanically isolated USB/RS-232 Interface, optional IEEE-488

1,2 GHz/3 GHz RF-SYNTHESIZER HM8134-3/HM 8135



from
\$4,524

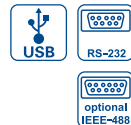

- ✓ Outstanding Frequency range 1 Hz...1,2 GHz/3 GHz
- ✓ Output power -127...+13 dBm / -135...+13 dBm
- ✓ Frequency resolution 1 Hz (accuracy 0.5 ppm)
- ✓ Input for external time base (10 MHz)
- ✓ Modulation modes: AM, FM, Pulse, Φ, FSK, PSK
- ✓ Rapid pulse modulation: typ. 200 ns
- ✓ Internal modulator (sine, square, triangle, sawtooth) 10 Hz...150 kHz/200 kHz
- ✓ High spectral purity
- ✓ Standard: TCXO (temperature stability: ± 0.5 x 10⁻⁶)
Optional: OCXO (temperature stability: ± 1 x 10⁻⁸)
- ✓ Galvanically isolated USB/RS-232 Interface, optional IEEE-488
- ✓ 10 configuration memories including turn-on configuration

HAPRO Electronics

Tel: +1-516-794-4080 · Fax: +1-516-794-1855 · sales@haproelectronics.com

www.hameg.us

HAMEG
Instruments
A Rohde & Schwarz Company



PICAXE PRIMER

■ BY RON HACKETT

SHARPENING YOUR TOOLS OF CREATIVITY

INTRODUCING THE NEW PICAXE M2-CLASS MICROCONTROLLERS

Back in July when I was just beginning to think about a topic for this month's Primer, Revolution Education released three new M2-class processors: the 08M2, 14M2, and 20M2. That settled the issue for me; I immediately ordered a bunch of them, and impatiently waited for the package to arrive at my doorstep. If you prefer to not wait as long as I did, all the M2 processors are now available here in the USA from Peter Anderson (www.phanderson.com/picaxe/index.html). In case you have been unable to locate a source for the AXE401 Shield Base, I should mention that Professor Anderson also carries the kit version of the AXE401 on his site.

BRIEF OVERVIEW OF SELECTED FEATURES OF THE M2-CLASS PROCESSORS

We don't have near enough space in this installment of the Primer to discuss all the significant new features of the M2 processors, so I'm going to limit our discussion to just a few of the most significant improvements to the older M-class devices. Naturally, the three new M2 processors have much in common with their older sibling — the PICAXE-18M2 — but they also add a few new tricks of their own, including a built-in internal temperature sensor and two powerful new commands (*rfin* and *rfout*) that will greatly simplify working with inexpensive RF wireless transmitters and receivers. (I'm sure we'll be exploring that capability before long!)

Figure 1 presents a summary of what I consider to be the most significant new features of the M2 processors.

To begin with, all M2 devices are able to operate with a supply voltage as low as 1.8V which means that battery-powered projects now only require a two-cell alkaline battery pack. In addition, the range of the internal clock frequency has been greatly expanded; all M2 processors can operate at nine different frequencies, from 31 kHz to 32 MHz.

Since power consumption is directly related to clock frequency, the new lower frequencies can be used to significantly extend the life of battery-powered projects. Of course, the maximum operating frequency of 32 MHz is four times faster than the 8 MHz maximum of the older M-class processors, which greatly

increases the range of possible M2 projects.

There are also several significant improvements in the memory capacity of the M2 processors. First, the program memory has been increased to 2,028 bytes which is eight times the capacity of the older M-class processors. Also, the 256-byte data (EEPROM) memory is now completely separate, so using it doesn't decrease the amount of available program memory. This means that all the M2 processors — including the tiny 08M2 — can run programs containing as many as 1,800 lines of BASIC code, which again greatly increases the range of possible M2 projects.

The number of general-purpose (GP) variables has been doubled from 14 to 28 (i.e., b0...b27) which also makes more complex projects possible. Finally, the amount of memory space available for "storage variables" has also been greatly

Feature	08M2	14M2	18M2	20M2
Voltage Range	1.8V - 5.5V	1.8V - 5.5V	1.8V - 5.5V	1.8V - 5.5V
Min. Internal Freq	31kHz	31kHz	31kHz	31kHz
Max. Internal Freq	32MHz	32MHz	32MHz	32MHz
Program Memory	2048 bytes	2048 bytes	2048 bytes	2048 bytes
General-Purpose Variables (b0Éb27)	28 bytes	28 bytes	28 bytes	28 bytes
Storage Variables	100 bytes	484 bytes	228 bytes	484 bytes
Total Variables	128 bytes	512 bytes	256 bytes	512 bytes
Pwmout channels	1	4	2	4

■ FIGURE 1. Selected features of the PICAXE M2 processors.

increased. (The M-Class processors supported 48 storage variables.)

This may not seem like such an important improvement at first. (How often have you needed more than 48 storage variables?) However, the M2 processors also now support the X2-class feature of “indirect addressing” of the storage variable memory. In case you’re not familiar with indirect addressing, we’re going to take a close look at it shortly because we can accomplish some really powerful tasks with it.

If you’re interested in microcontroller-based robotics, you will definitely want to check out the 14M2 and 20M2 processors which both include a total of four PWMOUT channels; two of them are entirely independent, and the other two share the “servo” timer. As a result, either processor can control two independent DC motors and several servomotors at the same time (or three independent DC motors). That’s an amazing amount of processing power for a small robot controller.

That’s about all the space we have this month to introduce the most significant new features of the M2 processors. If you’re interested in a more complete overview, RevEd has released a comprehensive M2 datasheet (PICAXE-M2 Product Briefing, available at www.rev-ed.co.uk/docs/picaxem2.pdf). At this point, we’re going to turn our attention to a project that’s been on my mind for some time, and the 14M2 is just the processor for the job.

IMPROVING OUR SERIAL LCD PROJECT

Back in June ‘09, we began our serial LCD project, and in August of that year we developed a major software driver for it. As you know, we used a PICAXE-14M processor which we pushed to its memory and speed limits. Even so, we had to make some compromises, especially in the requirement of sending data to the LCD in fixed-length packets. This

■ FIGURE 2. Breadboard setup for the *serrxd* experiment.

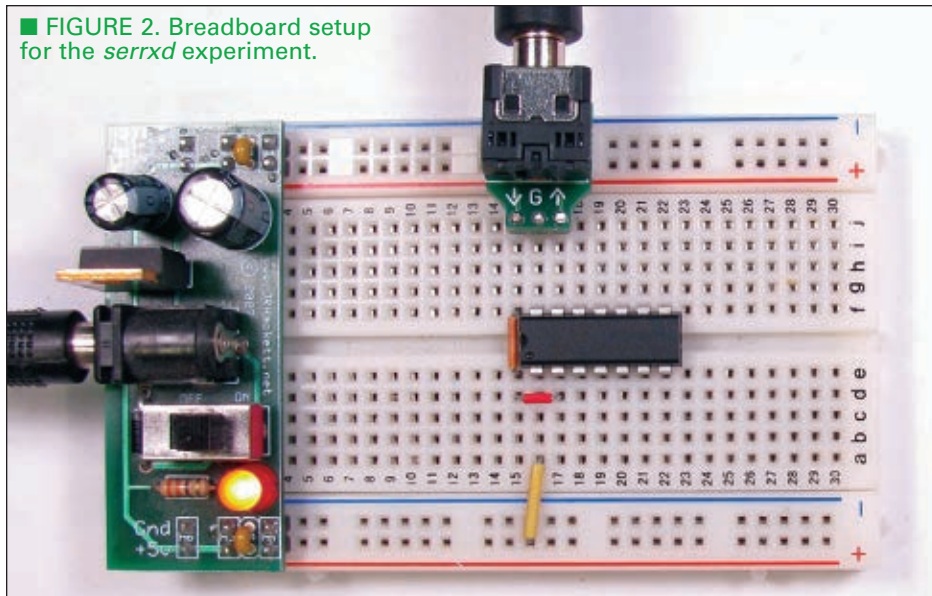

was necessary because the 14M’s *serin* command is “blocking” which means that whenever the 14M executes a *serin* command, the program stops running until the specified number of bytes have been received. (That’s why we needed to know how many bytes were going to be transmitted each time.)

One of the many software improvements in the M2-class processors is the inclusion of a *timeout* option for the *serin* and *serrxd* commands. The timeout option enables us to specify how long (in milliseconds) an M2 program should wait at a *serin* or *serrxd* command before “giving up” and moving on if no data is received. (We aren’t going to discuss it this month, but you may be interested in knowing that the M2 *irin* command now also has a timeout option.)

As long as we provide more than enough variables in which to store the incoming serial data, the new timeout option will enable our program to move on to processing the data, no matter how many bytes are actually received. That’s exactly the capability we need to improve our original serial LCD project.

With that in mind, as soon as I received my new M2 processors in the mail, I removed the 14M from one of my serial LCDs, replaced it with a 14M2, and began modifying the software. I spent more than two

days working on the program, and was getting nowhere. I just couldn’t get it to work at all, and the more I tried, the more frustrated I became. (Sound familiar?)

When I couldn’t stand it any more, I decided to take a break from it for a day or two, which is a strategy that has helped me in the past. When I returned to it, I simplified my approach, temporarily eliminating the LCD and using the terminal window for output. My goal was to develop a simple *serrxd* routine that would be able to accept a variable number of bytes as input. My breadboard setup for this experiment is shown in **Figure 2**. The programming adapter in the photo is the Prog-03 adapter. It’s designed specifically for the new M2 processors. As you can see, it minimizes the number of necessary connections (because it also directly connects to the ground rail).

The program we’ll be using (*SerrxdFastSimple.bas*) is included in the download files on the N&V website, along with the other two programs we’ll be using this month. We’ll use the following abridged version of the program to discuss the issues I encountered.

```
\ ***** SerrxdFastSimple.bas)
*****

#com 6
#picaxe 14M2
#no_data
#terminal 9600
```

```

setfreq m8
do
b0="*":b1="*":b2="*":b3="*" \
[1]
    sertextd ("> ")
    \ [2]
    serrxd b0
    \ [3]
    serrxd [1000],b1,b2,b3
    \ [4]
    reconnect
    \ [5]
    sertextd
(b0,b1,b2,b3,cr,lf) \ [6]
    wait 1
loop

```

In line 1, we're initializing the first four GP variables to "*" (ASCII char 42). Don't forget, it's okay to put multiple statements on the same line if you separate them with a colon. Line 2 simply displays a prompt in the terminal window. Line 3 is a traditional blocking *serrxd* command. Its purpose is to make the compiler wait at this point until a serial character is received, and then move on to the non-blocking *serrxd* command in line 4. This command includes a timeout option that instructs the compiler to "give up" after a timeout of 500 mS (at 8 MHz) if no additional serial input is received.

The *reconnect* command in line 5 requires a bit of explanation. We have often sent data from a PICAXE program to the terminal window for display, but I don't think we have done the reverse, i.e., sent data from the terminal window to a PICAXE program. It's easy to do; you just type the data into the *Output Buffer* area at the bottom of the terminal window and click the *Send* button. However, there is one important little complication.

Whenever a PICAXE program is running, the processor repetitively scans the *serin* line to see if the Programming Editor (or AxPad) wants to initiate a new program download. The scanning of the *serin* line would disrupt any serial input we want to send to the running program. To avoid this problem, the PICAXE compiler automatically issues a *disconnect* command in the background (see the *disconnect* documentation in Section 2 of the

PICAXE manual). Since the processor is now disconnected from the programming software, it's no longer possible to download a new program without first carrying out a *hard-reset* procedure (i.e., disconnecting the power to the processor, initiating the download, and then quickly restoring the power).

A simpler alternative is to include a *reconnect* command immediately after the *serrxd* commands so that program updates can again be downloaded to the processor without necessitating a hard-reset. Finally, line 6 simply transmits the four characters that are currently stored in the first four GP variables to the terminal window.

So, how should this program behave? Since the four GP variables are each initialized to "*" each time through the loop, entering each of the following strings in the *Output Buffer* and clicking *Send* should result in the indicated output, right?

```

Entering "a" should result in a
display of "a****"
Entering "as" should result in
a display of "as****"
Entering "asd" should result in
a display of "asd****"
Entering "asdf" should result
in a display of "asdf****"

```

I imagine you can guess the outcome – it doesn't work! What's a frustrated programmer to do?

THE PICAXE FORUM TO THE RESCUE (AGAIN)

I don't know about you, but I hate to admit when I can't solve a problem. However, I was beginning to think that there might be an issue with the new *serrxd* command, so I put my pride in my back pocket and posted a cry for help on the PICAXE Forum (www.picaxeforum.co.uk/forum.php). In about an hour, I received a reply from "Technical" (one member of RevEd's technical support team) confirming that there is, in fact, a bug in the current version of the Programming Editor software (v5.4.0, as of August '11). Ironically, this bug doesn't involve the new

timeout option of the *serrxd* command; it affects the older blocking version, and results in the command failing to wait for a serial input. The program immediately moves on to the next command even in the absence of any serial input!

Technical reassured me that the bug would be corrected in the next update of the Programming Editor software. Fortunately, Technical also provided a simple work-around that solves the problem until the software update is released. All I had to do was to replace line 3 in the above program with the following code:

```

bugfix:
    serrxd [60000,bugfix], b0

```

In order to fully understand why this work-around is effective, you may want to read the *serrxd* documentation in Section 2 of the PICAXE manual, but I'll briefly explain how it works. The *timeout* of 60000 forces the *serrxd* command to wait about 30 seconds (at 8 MHz) for the first serial character to arrive. If a character fails to arrive in that amount of time, the second optional parameter (*bugfix*) instructs the compiler to jump to the *bugfix* address. Since this address immediately precedes the *serrxd* command, the effect is to keep the compiler from advancing beyond this point in the program until the first character has been received.

If you modify the program to include Technical's work-around, you will see that it behaves exactly as we would predict. By the time you are reading this, version 5.4.1 of the Programming Editor will probably have been released, so you can just install it on your PC and test the program without the "bug fix" – it should work correctly. If not, let me know and we'll figure it out.

In addition to the *serrxd* issue we just discussed, I had two other minor problems as I was experimenting this month. First, in some of the programs I tested the terminal window failed to display the first line of text that was sent to it. Also, even when the first line did show up in the terminal window, there was frequently a single

“garbage” character preceding what I wanted to display.

Since I had already reached my maximum frustration-tolerance level, I didn’t hesitate to again ask for help on the PICAXE Forum. Within 20 minutes, I received a reply from “Hippy” (another member of RevEd’s technical support team) which explained that a newly downloaded PICAXE program starts running before the terminal window has time to open, so if the program sends data immediately, it will not display. The solution is simple: just put a delay at the beginning of the program.

A couple of hours later, Technical responded to my garbage character issue, asking me which download cable I was using. At the time, I was using a reconfigured FTDI cable with one of my new AxMate-MS programming adapters which – like the Prog-03 in **Figure 2** – is specifically designed for the new M2 processors. (I just can’t stop making programming adapters!)

Technical’s second reply directed my attention to the schematic diagram for the AXE027 PICAXE USB cable (www.rev-ed.co.uk/docs/axe027.pdf). In the schematic, I saw a 10K pull-down resistor on the serin line which I know isn’t included in the FTDI cable. In fact, that cable includes a 10K pull-up resistor on the serin line. I wasn’t sure what to do about that, but the first thing I tried (just adding a 10K pull-down) worked – the garbage character disappeared. Two problems and two solutions within a couple of hours, and it all transpired on a Saturday – that’s outstanding technical support!

Ultimately, I decided to permanently install the pull-down resistor on the bottom of my AxMate-MS adapter (see **Figure 3**). If you are using any FTDI-based USB adapter and getting the extra garbage character, you may also want to consider installing the 10K pull-down resistor.

Once my *serxd* routine was functioning correctly, I was ready to tackle the more complicated part of my serial LCD update project. One of the goals I had for the update was to

be able to change what’s displayed on both lines of the 16x2 LCD with one serial string. Since there could be a few LCD commands mixed in with the 32 characters that the LCD can display, I was determined to be able to receive and process strings as large as 40 characters.

As a result, the 28 GP variables that are now available on the M2 processors wouldn’t be enough to hold all the incoming data in my grandiose little scheme, so I decided to use the storage variables instead. As I mentioned earlier, the 14M2 contains 484 bytes of storage variables, so I was sure it could handle the largest LCD I could possibly find. In addition, the storage area in all M2 processors can be accessed using what’s referred to as *indirect* addressing which is much faster than the usual approach (i.e., *direct* addressing), so that’s the next topic we need to discuss.

DIRECT ADDRESSING OF VARIABLES

As we saw earlier in **Figure 1**, the M2 processors have 28 GP variables and many more storage variables. The values of these variables are stored in an area of RAM that’s known as the *byte scratchpad*. The M2 GP variables *b0* through *b27* are assigned to RAM locations 0 through 27 in the byte scratchpad, and the storage variable area begins at RAM location 28 and continues consecutively for however many storage variables the processor contains.

For example, the 14M2 contains a total of 512 bytes of RAM in the byte scratchpad (28 bytes for its GP variables and 484 bytes for storage variables). Since the GP variables occupy locations 0 through 27, the storage variable area in the 14M2 extends from location 28 to location 511.

The standard type of

addressing that we use when we work with the GP variables is referred to as *direct* addressing because we directly read or write the value that is stored at any given location in the byte scratchpad. For example, the value of the first GP variable (*b0*) resides at RAM location 0, so when we write *b0 = 5*, we’re directly storing the value 5 at location 0 in the byte scratchpad. If we define the name *myVar* for the *b0* variable (*symbol myVar = b0*), then we can also write *myVar = 5* to directly store the value 5 at location 0 in the byte scratchpad.

PICAXE BASIC includes two commands (*peek* and *poke*) that provide a second method of directly addressing the processor’s variables. For example, assuming we have already written (*symbol myVar = b0*), *poke myVar, 3* accomplishes the exact same thing as *myVar = 3*; the value 3 is stored in memory location 0. Of course, you probably would never use the *poke* command for that purpose, because it’s much simpler to write *myVar = 3*. However, *peek* and *poke* can also be used to directly access the storage variables as well, and the simpler method can’t because there are no names assigned

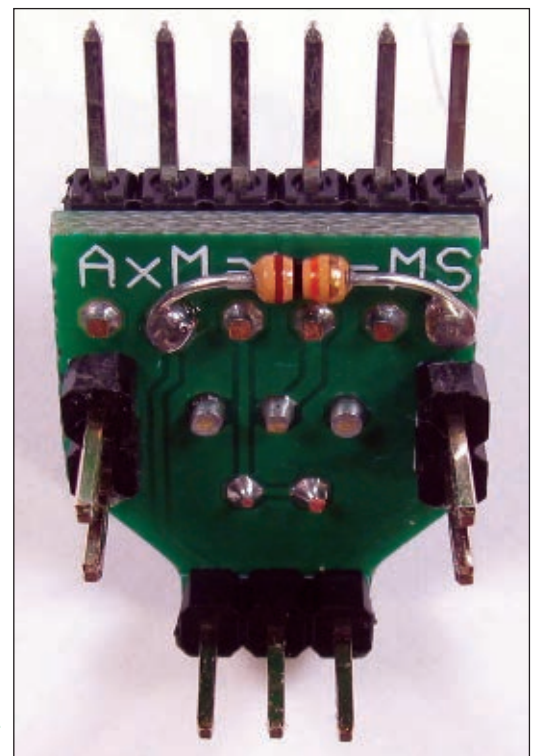

■ **FIGURE 3.** Pull-down resistor added to the AxMate-MS.

to the storage variables, and no way of assigning names to them.

For example, even if you write *symbol myStoreVar = 28*, you can't write *myStoreVar = 7* because you have defined a constant, not a variable. However, you can write *poke myStoreVar, 7* when you want to store the value 7 at the (constant) location 28.

The most important point to remember about the storage variables is that they can only be used to store and retrieve data; we can't assign convenient names to them or use them in any sort of calculations. For those purposes, we need the GP variables. In spite of these limitations, the storage variables are a very powerful feature of the M2 processors. To fully appreciate the power of the storage variables, we need to understand the concept of indirect addressing.

INDIRECT ADDRESSING OF VARIABLES

Indirect addressing is more complicated (and much more powerful) than *direct* addressing. Rather than directly addressing the memory location we want to access, indirect addressing uses the concept of a *pointer* variable which "points to" the desired address. PICAXE BASIC includes the following four built-in special function variables that we can use to implement indirect addressing (I'll explain each one shortly):

bptr – (pronounced *bee pointer*); the byte scratchpad pointer.

@bptr – (pronounced *at bee pointer*); the byte scratchpad value pointed to by bptr.

@bptrinc – (pronounced *at bee pointer inc*); the byte scratchpad value pointed to by bptr (post increment).

@bptrdec – (pronounced *at bee pointer dec*); the byte scratchpad value pointed to by bptr (post decrement).

The byte scratchpad pointer

(*bptr*) is used to point to the location we want to access, and the other three variables automatically contain the value that's stored at the location pointed to by *bptr*. I know that sounds confusing, so let's take a look at a simple program to clarify all this. (the line numbers are included for the following discussion):

```
` **StorageVarDemo.bas **
#com 6
#picaxe 14M2
#no_data
#terminal 9600

setfreq m8

bptr = 28 ` [1]

for b0 = 65 to 90 ` [2]
    @bptrinc = b0 ` [3]
next b0 ` [4]

@bptr = 0 ` [5]

bptr = 28 ` [6]

do until @bptr = 0 ` [7]
    sertxd (@bptrinc) ` [8]
loop ` [9]
```

In line 1, *bptr* is initialized to 28 (the first storage variable location). In lines 2-4, we're executing a *for...next* loop 26 times. The start and end values for the loop (65 and 90) correspond to the ASCII values for "A" and "Z," so the first time line 3 is executed, the ASCII character "A" is stored at the location pointed to by *bptr*, and then *bptr* is automatically incremented in preparation for the next iteration of the loop. (This automatic incrementing of *bptr* is what makes indirect addressing so powerful.)

The second time through the loop, "B" is stored at location 29, and *bptr* is again automatically incremented. When the loop has finished executing, the characters "A" through "Z" have been sequentially stored at locations 28 through 53. At this point, *bptr* = 54 because it started at 28 and was automatically incremented 26 times. In line 5, we're storing the value zero (which is a non-printing ASCII character) at location 54. We're going to use the zero as an "end of string" marker, as we're about to see.

In line 6, we need to reset *bptr* back to its initial value of 28 in

preparation for sending the received characters to the terminal window. Here's where our end of string marker comes into play. In lines 7-9, we execute a *do until...* loop that sends each stored character to the terminal window and automatically increments *bptr* in preparation for the next iteration of the loop. When we reach the zero, the loop immediately terminates, so the zero is not sent to the terminal window.

The program we just examined is also included in this month's downloads. If you don't yet have them, it would be a good idea to download all three programs at this point, and spend some time experimenting with *StorageVarDemo.bas* so that you have a good understanding of indirect addressing. When you're ready, we'll move on to our next program.

USING INDIRECT ADDRESSING TO SPEED UP RECEPTION OF SERIAL DATA

This program (*SerrxdFast14M2.bas*) combines the benefits of the *serrxd* timeout option with the speed of indirect addressing to efficiently process large, variable-length serial data strings. Before you run *SerrxdFast14M2.bas*, there are a couple of points I want to mention, so you may want to print out a copy for reference. First, there's no *reconnect* statement in the program; just a *disconnect* statement near the beginning. *Reconnect* can't be used in this program because it loops back around to the first *serrxd* statement (which — as you remember — includes an automatic *disconnect*) so quickly that the program is hardly ever scanning for a new download. Therefore, the only way to initiate a new download in situations like this is to carry out the *hard-reset* procedure mentioned earlier (i.e., disconnect the power to the processor, initiate the download, and then quickly restore the power).

SerrxdFast14M2.bas uses the

same bugfix work-around that was included in *SerrxdFastSimple.bas*, except now we're storing the first data byte in the storage area rather than in a GP variable. The second *serrxd* statement also uses the storage area to hold as many as 49 additional bytes of incoming data. The statement may look a little strange due to its unusual length, but this approach is much faster than trying to accomplish the same thing in a loop.

I assume there is some preset maximum length for a single line in the Programming Editor, but just for fun, I ran the program with twice as many *@bptrinc* parameters in this line and it worked perfectly. Of course, this suggests that we could use the same approach to fill a 20x4 LCD with one serial command, but that's a project for another time!

When you have read through the program and understand how it should work, download *SerrxdFast14M2.bas* to your 14M2 processor and try it out. If you have any problems with it, email me (Ron@JRHackett.net) and I'll try to help.

UPDATING OUR SERIAL LCD "CUSTOM CHARACTER" DRIVER

The *SerrxdFastSimple.bas* demonstrates all the programming techniques we need to update the *LCD16x2-CustCharDriver.bas* program (June '09) so that it can handle variable-length serial input without missing a character. I'm happy to say that I was able to do that without encountering any additional problems along the way. Unfortunately, there isn't enough space to discuss the updated software this month.

However, I also don't want you to have to wait another two months for the denouement of this month's project, so I'll post the updated software, along with an explanation of its features on my website (see www.jrhackett.net/LCD16.shtml).

See you next time ... **NV**

BlueWolf ROBOTICS
www.bluewolfinc.com

RS-232 ADAPTER MODULE \$9.95

USB XBee EXPLORER BOARD \$19.95

Check out LOBO!
OUR 3 VOLTAGE SOURCE REGULATOR BOARD!

MAXBOTIX - MAX SONAR EZ1 \$24.95

LED BOARD KITS \$1.49

RESISTORS: 1/4W 5% CARBON FILM SEVERAL TO CHOOSE FROM!

SWITCH TACT 6MM SQL=7.0MM 160GF \$5.95

BATTERY HOLDER W/9V SNAP \$2.99 & 9V BATTERY SNAP \$3.99

SERVO EXTENDER CABLE- 6" \$1.65

USB MINI-B CABLE-3' \$3.95

Boe-Bot Robot with FlashFly Combo Pack!
WAS \$259.00 NOW \$233.95!

CALL US TODAY ABOUT OUR EDUCATION & ROBOTICS CLUB DISCOUNTS!
(208) 629-5222 www.bluewolfinc.com / info@bluewolfinc.com

ENJOY SCARY DISCOUNTS!
ENTER COUPON CODE: OCT15 For 15% OFF

Twitter Facebook YouTube

EARN MORE MONEY

Get your dream job!

Be an FCC Licensed Wireless Technician!

Make up to \$100,000 a year and more with NO college degree

Learn Wireless Communications and get your "FCC Commercial License" with our proven Home-Study Course!

- No need to quit your job or go to school.
- This course is easy, fast and low cost.
- No previous experience needed!
- Learn at home in your spare time!

Move to the front of the employment line in Radio-TV, Communications, Avionics, Radar, Maritime and more... even start your own business!

Call now for FREE info
800-932-4268 ext. 209
Or, online:
www.LicenseTraining.com

COMMAND PRODUCTIONS
Warren Weagant's FCC License Training
P.O. Box 3000, Dept. 209 • Sausalito, CA 94966
Please rush FREE info immediately!

NAME: _____
ADDRESS: _____
CITY/STATE/ZIP: _____
email: info@LicenseTraining.com



RAMSEY Spooktacular Halloween Treats!



Blinky-Eyes Animated Display

- ✓ Animated display of 66 super bright LED's!
- ✓ Microcontroller controlled!
- ✓ Changes brightness automatically!
- ✓ Animated with constant motion!

The ultimate animated LED kit that will dazzle you and delight your friends! Uses a microcontroller to randomly select from many different animations such as a long pause before a wink, or a twinkle of the eye to startle passers-by!

Four modes to satisfy any enthusiast's desires: 1. Off for long random periods, then blinks or winks. Designed to scare! 2. On for long periods before performing an animation, perfect for costumes and displays! 3. Animates all the time for constant motion, perfect display attention-getter. 4. Random fire! When placed in a pumpkin will light it up like you wouldn't believe! As if this weren't enough, the BE66 can also control a small hobby motor to shake bushes at random intervals or signal an external player to make a scary sound! Also has a CDS cell to sense light. In one mode, the display will dim as it gets dark for battery operation, and in the other it will turn off when it's too bright, so it plays only in the dark!

BE66 Blinky-Eyes Animated Display Kit \$59.95

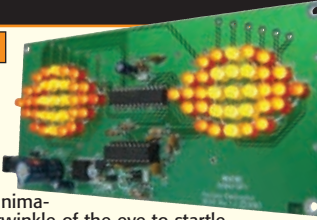

Automatic Animated Ghost

- ✓ Automatically greets your visitors!
- ✓ Responds to sudden noises!
- ✓ Built-in microphone!
- ✓ Adjustable sensitivity

Who says ghosts are make believe? Once your friends come upon this one they'll think differently! The unique circuit board design includes two ominous blinking eyes that change with various conditions, including sudden changes in ambient noise. A highly sensitive built-in microphone picks up anything from noises to talking and makes the ghost dance with its built-in motor, make eerie sounds with the built-in speaker, and randomly blink. A white cloth and a hanger are included as shown to make it look like the real thing. Runs on 2 AAA batteries (Not included).



MK166 Automatic Animated Ghost Kit \$21.95

Halloween Pumpkin

- ✓ 25 bright LED's!
- ✓ Random flash simulates flickering candle!
- ✓ Super bright LED illuminates entire pumpkin!
- ✓ Simple & safe 9V battery operation

The perfect "starter" kit with a terrific Halloween theme! You won't be scraping the seeds and guts out of this pumpkin! Six transistor circuit provides a neat random flash pattern that looks just like a flickering candle. Then a super bright LED illuminates the entire pumpkin with a spooky glow!

The pumpkin face is the actual PC board, and assembly is easy through-hole soldering of all components and LED's. Your pumpkin is powered by a standard 9V battery (not included) which snaps to the back of the pumpkin. An on/off switch is also included. Create a new kind of pumpkin this year, and learn about LED's and electronics at the same time!

MK145 Electronic Halloween Pumpkin Kit \$11.95



Laser Light Show

- ✓ Audio input modulates pattern!
- ✓ Adjustable pattern & size!
- ✓ Projects neat motorized patterns!
- ✓ Uses safe plastic mirrors!

You've probably seen a laser show at concerts or on TV. They're pretty impressive to say the least! Knowing that you can't afford a professional laser display we challenged our engineers to design one that's neat and easy to build, yet inexpensive.

Well, the result is the LLS1 Laser Light Show! This thing is sweet and perfect for your haunted house or halloween parties! It utilizes two small motors and a small standard laser pointer as the basics. Then, we gave it variable pattern and speed controls to customize the pattern!

Not enough, you say? How about a line level audio input to modulate the pattern with your CD's, music, or spooky sound effects? You bet! Everything is included, even the small laser pointer. Runs on 6-12 VDC or our standard AC adapter.

LLS1 Laser Light Show Kit \$49.95
AC125 110VAC Power Supply \$9.95

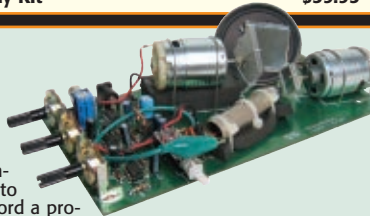

Tri-Field Meter & "Ghost Detector"

- ✓ See electric, magnetic, and RF fields!
- ✓ Watch the magnetic fields of the earth!
- ✓ Sense different magnetic poles
- ✓ Detect RF transmitter fields
- ✓ Graphical LED display allows you to "see" the invisible fields
- ✓ Great learning tool for EMF, RF, and magnetic field theory.

Call it a Tri-Field Meter, an Electrical, Magnetic, and RF Detector, a Ghost Detector, or a Tricorder, but walking around with this on Halloween will seriously impress even the most doubting!

The TFM3C has three separate field sensors that are user selectable to provide a really cool readout on two highly graphical LED bargraphs! Utilizing the latest technology, including Hall Effect sensors, you can walk around your house and actually "SEE" these fields around you! You will be amazed at what you see. How sensitive is it? Well, you can see the magnetic field of the earth... THAT'S sensitive!

The technical applications are endless. Use it to detect radiation from monitors and TV's, electrical discharges from appliances, RF emissions from unknown or hidden transmitters and RF sources, and a whole lot more! If you're wondering whether your wireless project or even your cell phone is working, you can easily check for RF! A 3-position switch in the center allows you to select electric, magnetic, or RF fields. A front panel "zero adjust" allows you to set the sensors and displays to a known clean "starting point!"

If the TFM3C looks familiar, it's probably because you saw it in use on the CBS show Ghost Whisperer! It was used throughout one episode (#78, 02-27-2009) to detect the presence of ghosts!

The concept is simple, it is believed (by the believers!) that ghosts give off an electric field that can be detected with the appropriate equipment. In the electric mode, the TFM3C's displays will wander away from zero even though there isn't a clear reason for it (not scientifically explainable, aka paranormal!). This would mean something has begun to give off an electric field. What it was in the Ghost Whisperer was a friendly ghost. What it will be in your house... who knows! Makes a GREAT leaning project besides! Requires 4 AA batteries.

TFM3C Tri-Field Meter Kit With Case \$74.95



Portable EL Electroluminescence

- ✓ 3.3 feet long!
- ✓ Low power consumption!
- ✓ Highly visible brilliant colors

Electroluminescence illuminated flexible wire sets can be used for a lot of things but when they're battery powered they're perfect for Halloween and Trick or Treat safety concerns! Each thin, flexible EL wire set is 3.3' long and runs on two standard AA batteries (not included). Current consumption is less than 100mA for long life.

Mode settings include steady glow and slow or fast flash! Make it part of a brilliantly lit, custom designed costume or simply add it for illuminated safety while Trick or Treating in the dark.

NWRR15 EL Illumination Wire Set, Red \$19.95
NWRG15 EL Illumination Wire Set, Green \$19.95
NWRB15 EL Illumination Wire Set, Blue \$19.95



Spark Generating HV Plasma Generator

- ✓ Generate 2" sparks to a handheld screwdriver!
- ✓ Light fluorescent tubes without wires!
- ✓ Build your own Plasma Balls!
- ✓ Generates up to 25kV @ 20 kHz from a solid state circuit!



This popular kit was conceived by one of our engineers who likes to play with things that can generate large, loud sparks, and other frightening devices! And at Halloween there's no better effect than high voltage sparks flying through the air! The PG13 Plasma Generator creates a very impressive 25,000 volts at 20 kHz, to provide a stunning display of high voltage! It will draw a cool looking 2" spark to hand held screwdriver, or light fluorescent tubes without any connection!

It produces stunning lighting displays, drawing big sparks, to perform lots of high voltage experiments. In the picture, we took a regular clear "Decora" style light bulb and connected it to the PG13 - WOW! A storm of sparks, light tracers and plasma filled the bulb. Holding your hand on the bulb doesn't hurt a bit and you can control the discharge! It can also be used for powering other experiments; let your imagination be your guide! Operates on 16VAC/VDC for maximum output. Can also be run from 5-16VAC/VDC to reduce the output voltage.

PG13 Plasma Generator Kit \$64.95
PS21 110VAC Input, 16VAC Output, Power Supply \$19.95



OBDII CarChip Pro

The incredible OBDII plug-in monitor that has everyone talking! Once plugged into your vehicle it monitors up to 300 hours of trip data, from speed, braking, acceleration, RPM and a whole lot more. Reads and resets your check engine light, and more!



8226 CarChip Pro OBDII Monitor \$79.00

Practice Guitar Amp & DI

Practice your guitar without driving your family or neighbors nuts! Works with any electric, acoustic-electric, or bass guitar. Plug your MP3 player into the aux input and practice to your favorite music! Drives standard head-phones and also works as a great DI!



PGA1 Personal Practice Guitar Amp Kit \$64.95

Passive Aircraft Monitor

The hit of the decade! Our patented receiver hears the entire aircraft band without any tuning! Passive design has no LO, therefore can be used on board aircraft! Perfect for air-shows, hears the active traffic as it happens! Available kit or factory assembled.



ABM1 Passive Aircraft Rcvr Kit \$89.95

LED Blinky

Our #1 Mini-Kit for over 35 years! Alternately flashes two jumbo red LED's. Great for signs, name badges, model railroading, and more. Used throughout the world as the first learning kit for students young and old! Great solder practice kit. Runs on 3-15 VDC.



BL1 LED Blinky Kit \$7.95

LED SMT Blinky

The subminiature high-tech version of the BL1! Utilizes all SMT components to drive a pair of high intensity SMT LED's. Runs on 2 button cells (included). Great attention grabber for signs, hats, or other applications.



BL2 LED SMT Blinky Kit \$17.95

Electronic Siren

Exactly duplicates the upward and downward wail of a police siren. Switch closure produces upward wail, releasing it makes it return downward. Produces a loud 5W output, and will drive any speaker! Horn speakers sound the best! Runs on 6-12VDC.



SM3 Electronic Siren Kit \$7.95

Universal Timer

Build a time delay, keep something on for a preset time, provide clock pulses or provide an audio tone, all using the versatile 555 timer chip! Comes with circuit theory and a lots of application ideas and schematics to help you learn the 555 timer. 5-15VDC.



UT5 Universal Timer Kit \$9.95

Electronic Watch Dog

A barking dog on a PC board! And you don't have to feed it! Generates 2 different selectable barking dog sounds. Plus a built-in mic senses noise and can be set to bark when it hears it! Adjustable sensitivity! Unlike the Saint, eats 2-8VAC or 9-12VDC, it's not fussy!



K2655 Electronic Watch Dog Kit \$39.95

USB DMX Lighting Interface

Control DMX fixtures with your PC via USB! Controls up to 512 DMX channels each with 256 different levels! Uses standard XLR cables. Multiple fixtures can be simply daisy chained. Includes Light Player software for easy control. Runs on USB or 9V power.



K8062 USB DMX Interface Controller Kit \$67.95

20 Watt Mini Audio Amp

Delivers a super clean 20W output from one SMT package! Ultra efficient class D design produces no heat. PCB can be snapped into a small circle for special applications. Runs on 18VDC for rated output, or down to 10VDC for reduced output.



UAM2 20W Subminiature Amp Kit \$39.95

Touch Switch

Touch on, touch off, or momentary touch hold, it's your choice with this little kit! Uses CMOS technology. Actually includes TWO totally separate touch circuits on the board! Drives any low voltage load up to 100mA. Runs on 6-12 VDC.



TS1 Touch Switch Kit \$9.95

Walking Electronic Bug

Built around a pair of subminiature cell phone motors, this bug wanders around looking for things to bump into! Sensors below his LED eyes sense proximity and make him turn away! Steer him with flashlights too! Runs on two "N" batteries.

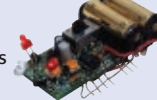

WEB1 Walking Bug Kit \$29.95

Mad Blaster Warble Alarm

If you need to simply get attention, the "Mad Blaster" is the answer, producing a LOUD ear shattering raucous racket! Super for car and home alarms as well. Drives any speaker. Runs on 9-12VDC.



MB1 Mad Blaster Warble Alarm Kit \$9.95

Xenon Tube Strobe Light

Create amazing effects with an authentic Xenon tube strobe light! Creates a super bright white FLASH with a variable speed of 2 to 20 flashes second. Just connect 110VAC and you have a complete strobe light!



K5300 Xenon Tube Strobe Light Kit \$19.95

Stereo Ear Super Amplifier

Ultra high gain amp boosts audio 50 times and it does it in stereo with its dual directional stereo microphones! Just plug in your standard earphone or headset and point towards the source. Incredible gain and perfect stereo separation!



MK136 Stereo Ear Amp Kit \$9.95

Water Sensor Alarm

This little \$8 kit can really "bail you out"! Simply mount the alarm where you want to detect water level problems (sump pump!). When the water touches the contacts the alarm goes off! Sensor can even be remotely located. Runs on a standard 9V battery.



MK108 Water Sensor Alarm Kit \$6.95

Air Blasting Ion Generator

Generates negative ions along with a hefty blast of fresh air, all without any noise! The steady state DC voltage generates 7.5kV DC negative at 400uA, and that's LOTS of ions! Includes 7 wind tubes for max air! Runs on 12-15VDC.



IG7 Ion Generator Kit \$64.95

Retro Nixie Tube Clock

Genuine Nixie tubes popular in the 50's brought back in one of the neatest digital clocks around today! This compact unit is great to build into your own enclosure or order our custom plexiglass enclosure. Requires 12VDC 500mA.

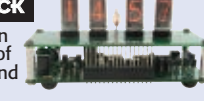

K8099 Compact Nixie Clock Kit \$139.95

SMT Soldering Lab

Learn all about SMT parts and how to solder them! Surface mount parts are tiny and require a special skill to solder. This lab and course covers it all, and you end up with a great "Decision Maker" kit when done!



SM200K SMT Soldering Lab Kit \$22.95

Soldering Lab

The perfect beginner's project specifically designed to teach you the fundamentals of soldering and PC boards. You will not only learn soldering, but how to troubleshoot soldering problems and how to fix them! Final project runs on 9V battery.



SP1A Soldering Lab Kit \$9.95

Soldering Parts Lab

Not only will you learn soldering and desoldering but you will also learn component identification and color codes! Includes 163 solder points, and you will learn how to solder all types of components. The comprehensive manual even includes exams!

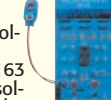

SP3B Soldering Parts Lab Kit \$9.95

IC AM/FM Radio Lab

Learn all about AM/FM radio theory, IC theory, and end up with a high quality radio! Extensive step-by-step instructions guide you through theory, parts descriptions, and the hows and whys of IC design. Runs on a standard 9V battery.

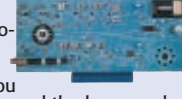

AMFM108K AM/FM IC Radio Lab Kit \$34.95

Non-Conductive Tweezers

We've discussed tweezers and magnifiers while working with SMT components. Working with highly sensitive components, ESD safe tweezers can be a life saver! This set of 4 non-conductive tweezers are perfect for any static sensitive devices, and are priced right!



VTTWSET2 Non-Conductive Tweezers Set \$3.95

3-In-1 Multifunction Lab

The handiest item for your bench! Includes a RoHS compliant temp controlled soldering station, digital multimeter, and a regulated lab power supply! All in one small unit for your bench! It can't be beat!



LAB1U 3-In-1 Multifunction Solder Lab \$134.95



Get The Catalog!

Get the latest 2011 Ramsey Hobby Catalog! 96 value packed pages of the neatest goodies around with lots of new stuff! Order yours today on line or give us a call... Or download the PDF at www.ramseykits.com/catalog/!



www.ramseykits.com



RAMSEY ELECTRONICS®
590 Fishers Station Drive
Victor, NY 14564
(800) 446-2295
(585) 924-4560

800-446-2295

Where Electronics Is Always Fun!

- ◆ Build It!
- ◆ Achieve It!
- ◆ Learn It!
- ◆ Enjoy It!

Prices, availability, and specifications are subject to change. Not responsible for typos, stupids, printer's bleed, or really weird Halloween tricks! Visit www.ramseykits.com for the latest pricing, specials, terms and conditions. Thanks Robin... for reminding me of this ad deadline and that Halloween is approaching! Therefore today's color theme is Pantone 021C Orange! Copyright 2011 Ramsey Electronics®...so there!

Q&A

WHAT'S UP:

Join us as we delve into the basics of electronics as applied to every day problems, like:

- ✓ VFD Filament Driver
- ✓ Current Sense for a Data Logger
- ✓ Gel Cell Charging Voltage

WITH RUSSELL KINCAID

In this column, I answer questions about all aspects of electronics, including computer hardware, software, circuits, electronic theory, troubleshooting, and anything else of interest to the hobbyist. Feel free to participate with your questions, comments, or suggestions. Send all questions and comments to: Q&A@nutsvolts.com

CONVERT RELAY LOGIC

I am relatively fluent in relay circuit configurations, but feel incompetent when it comes to IC design and PCB fabrication.

My goal is to replace two three-relay gate circuits with two IC counterparts. Each set of three relays

has its N/O contacts connected in series to detect simultaneous occurrence of three independent phenomena.

The relays operate from separate negative-going 12V signal inputs.

My exploration thus far suggests that two of the three three-input NOR gates on a CD4025BEE4 IC will provide the starting point for the

replacement circuit.

One drawback of the simple IC gate is that it will respond to momentary coincidence of all three inputs. In contrast, the inherent inertia of the relays means that all three inputs must be present for upwards of 10 milliseconds before all three relay's contacts close.

This need to ensure that all three inputs have been present for 10 milliseconds or more adds a layer of complexity to the simple IC configuration.

An R/C de-bounce circuit ahead of each input to the NOR gate seems like a good starting point. Would an R/C de-bounce circuit with a trimpot for each input be practical?

I need each of the two three-input gate circuits to feed its own buffer, capable of delivering 1A for additional circuit activation.

Besides driving separate 1A buffers, the two gates will also drive a common ONE SHOT that delivers an output whose duration is trimpot-adjustable between 150 milliseconds and one second. (Isolation diodes will separate the two gates.)

The ONE SHOT, in turn, drives a 1A rated buffer whose output is a negative 150 ms - 1 sec 12V pulse.

That's the story in a nutshell. I hope this provides enough information to ask further questions. I'd like to up the ante and add two more identical ONE SHOTS to the PCB. Is this okay?

Another tweak. The "central" ONE SHOT drives a 24V stepper and

Separating The Debounce & Capacitive Coupling Functions

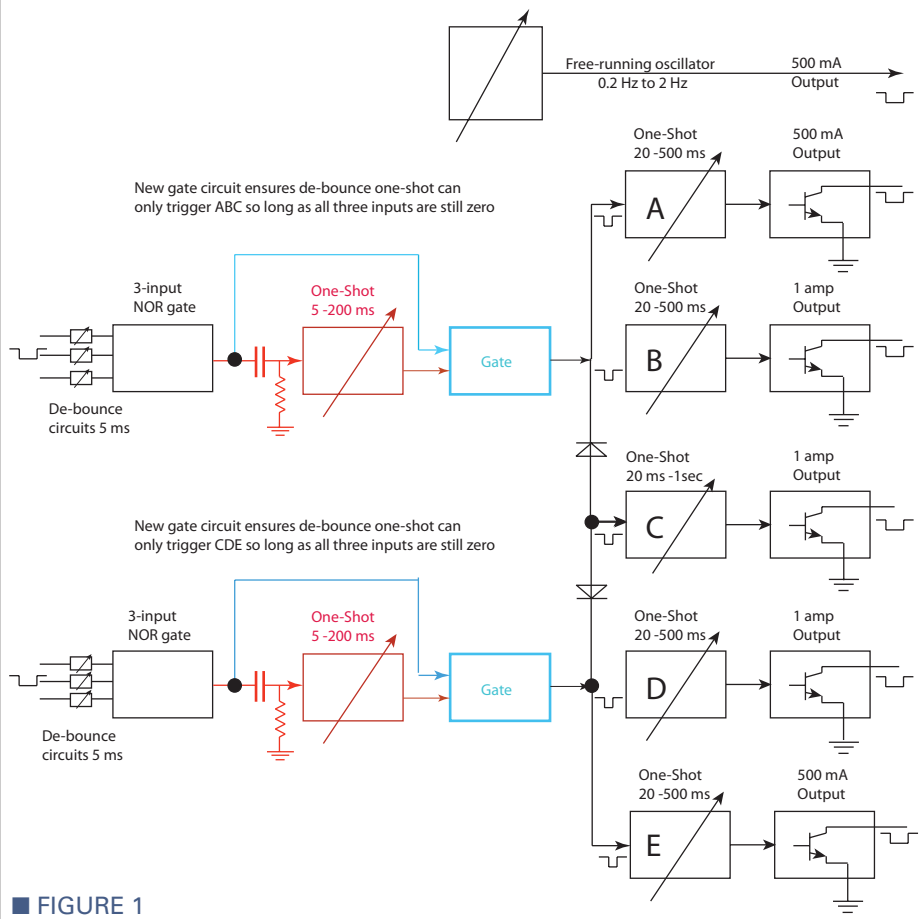
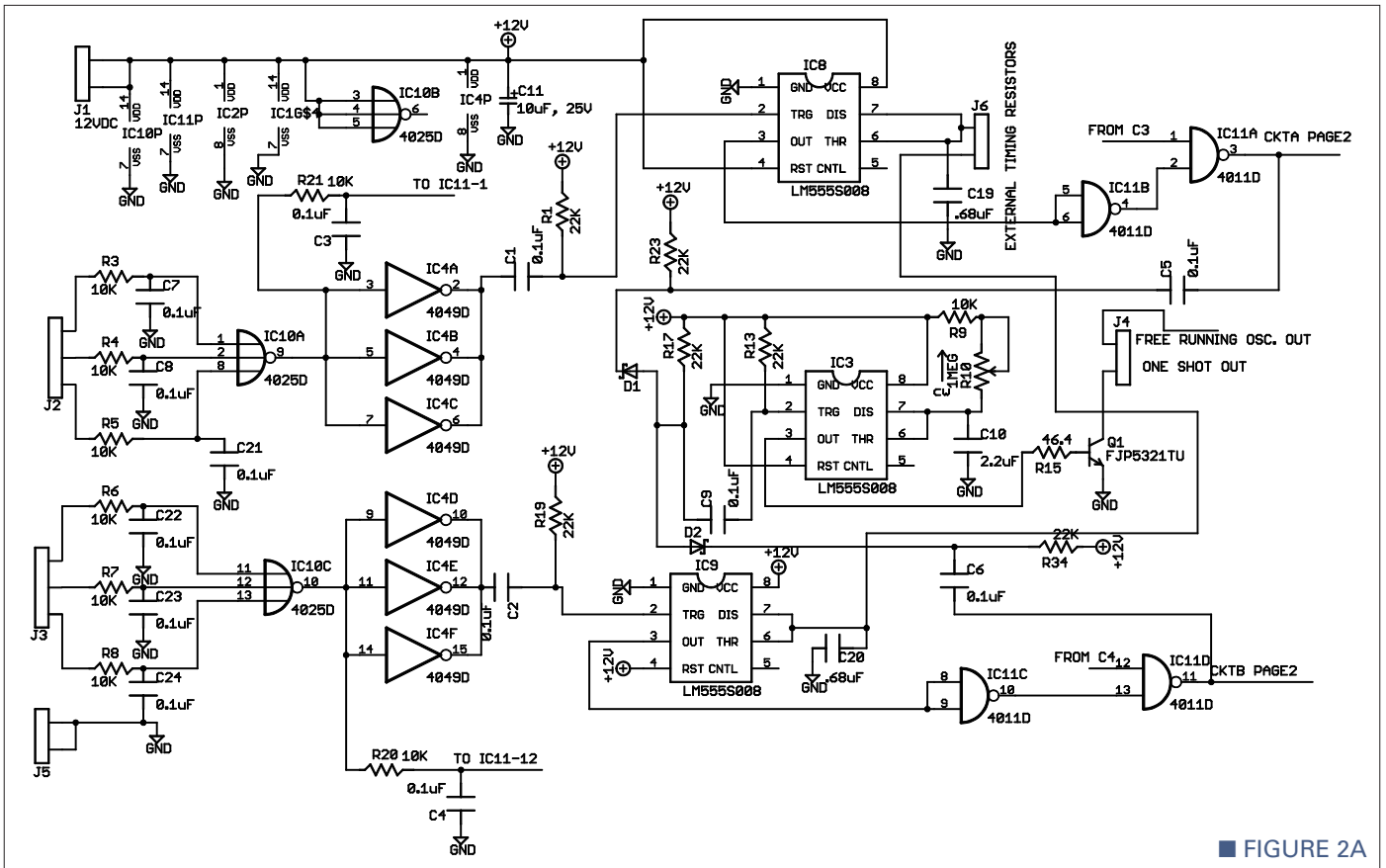

FIGURE 1



■ FIGURE 2A

requires a high voltage 1A output transistor.

In the revised diagram, the center ONE SHOT is triggered by the firing of either gate. In addition, two ONE SHOTS are now triggered when either of the gates is fired. The center ONE SHOT has a maximum cycle time of one second; the other four have half-second timing.

Instead of using a single resistor-capacitor circuit to provide both de-bounce and capacitive coupling, I'd like to up the ante again and separate these two functions. Can you please make these additions?

1. Add the two ONE SHOTS to the circuit.
2. Add a variable frequency oscillator 0.2 Hz to 2 Hz with potentiometer control.

Figure 1 conveys the general two-step idea. Add two new ONE SHOTS to provide the de-bounce delay, and capacitive-couple the three-input gate outputs to the two

new ONE SHOTS.

I plan to use two (ganged) 10-position selector switches to select various de-bounce timing resistor values. Can you please include terminals for selector switch connections?

— Stanley Froud

A Now that we have a final block diagram (**Figure 1**), take a look at the schematic before committing to hardware. The input NOR gate acts as an inverted AND. The output is inverted to trigger the ONE SHOT. The rest of the circuit (see **Figure 2**) is all ONE SHOTS, so not much of a challenge. I used some 556 dual ONE SHOTS for a slight savings in space and cost, but in a production environment I might choose all 555s to maximize purchasing power and minimize stocking. The use of surface-mount parts is the biggest savings because the cost of the printed circuit board is based on the area and number of holes.

VFD FILAMENT DRIVER

Q I enjoy the look of Vacuum Fluorescent Displays, and use them wherever I can. My challenge is driving the filament properly. It is traditionally driven with an AC source, taken from a special winding on the power supply transformer. The filament is also the cathode of the display. The transformer winding usually has a center tap which is used as the display cathode connection to which the grid and anode are biased.

This is done to ensure even lighting of the VFD, especially in tubes with multiple segments. In this age of power bricks, etc., a transformer is often not used (as well as unavailable), and the filament is driven by a square wave with a 50% duty cycle in the pos and negative direction (essentially, a square AC). National Semiconductor made a chip to do just that — the LM9022. It is now obsolete, and has all but disappeared

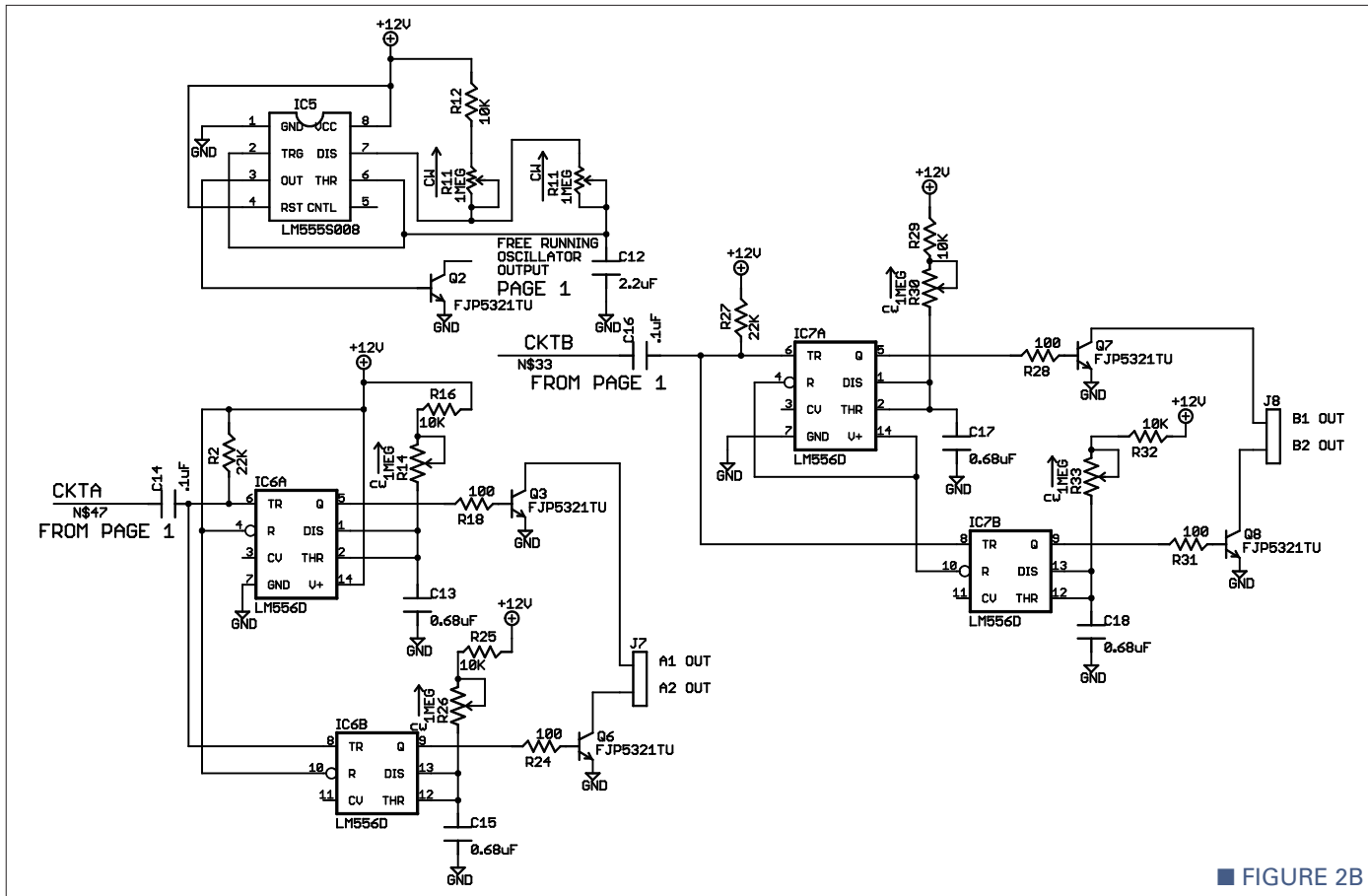

■ FIGURE 2B

from the market.

My question is this: Could you propose a small schematic to substitute for this chip? The output voltage is usually in the range of one to four volts (to be adjustable for different tubes), and current draw is around 40 to 50 mA per tube. It would be great if the circuit could drive at least six tubes (parallel

filaments) for a current around 300 mA as a minimum. The input voltage could be either a fixed 5V or something between 12 and 50V, since both are usually available in the VFD design. Also, Noritake proposes to use a filament frequency for this type of drive of 10 kHz or more to prevent any flickering effect.

— Bill van Dijk

AI started out considering a variable pulse width circuit which would allow operation from either +5 or +12 volts, but then thought about the problem of determining the RMS value such that the filament is not overheated. The RMS of a square wave is just the amplitude, so that would make it easy to get the right value. Noritake advocates an AC center tap configuration, so that is what I will do.

In **Figure 3**, the 555 oscillator runs at 100 kHz and is divided by two in IC2. I paralleled the outputs of IC2 in order to increase the drive to the MOSFETs. IC1 and Q3 are a DC supply for the transformer. If you want 3V RMS output, just set the emitter of Q3 to 3V.

The transformer is 1:1, center-tapped. Since the output is to be 300 mA

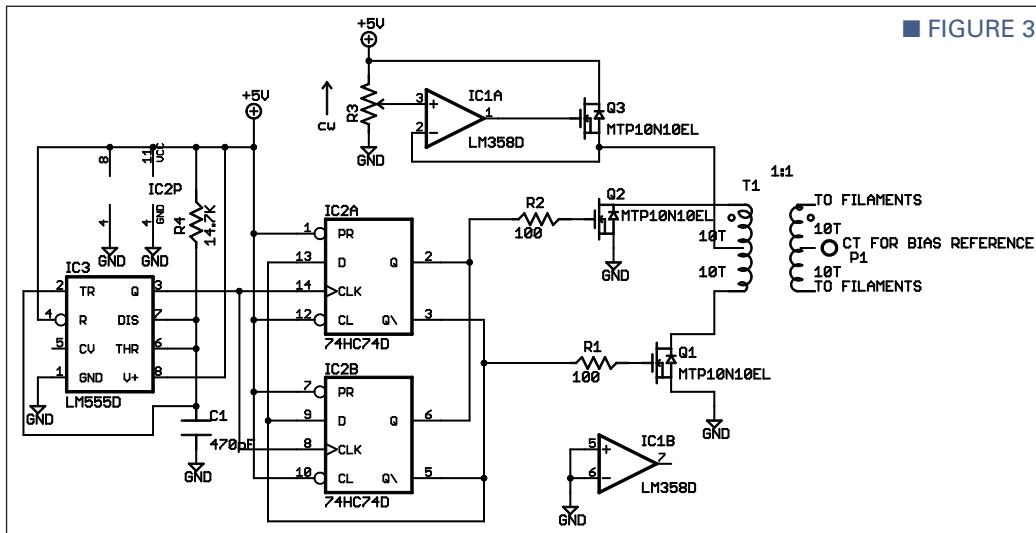

■ FIGURE 3

max, the magnetizing current at the input should be no more than 30 mA. I will try 10 mA which means the inductive reactance will be $5V/.01 = 500$ ohms. Since the frequency is 50 kHz, the inductance has to be $L = Xl/2\pi F = 1.59$ mH.

Calculating the turns from $N = (L * 1e6 / \mu A)^{.5}$, then $N = .74$. That's not reasonable. I can use more turns. Twenty turns will fit in one layer on the bobbin, so use 10 turns to the center-tap, then $L = 230$ mH. Now, check to see if the core is big enough: $WaAc$ for the core is given as .162. $WaAc$ is the product of the core cross-section and the window area. The equation is:

$$WaAc = k * P_o * 10^8 / B / F$$

where

- $k = .00528$ for an E core
- $P_o = 5V * 0.3A = 1.5$ watt
- $B = 1000$ gauss
- $F = 50$ KHz

Then:

$WaAc = .0016$ and the core is much larger than needed.

The wire size can be calculated from: $AWG = -4.31 * \ln(1.889 * I / Cd)$, where Cd is the current density in amperes per square centimeter. The Micrometals manual recommends 400 A/sq cm.

That yields an AWG of #28; anything bigger is okay.

CURRENT SENSE FOR A DATA LOGGER

Q I have a DATAQ EL-USB-5 data logger. I want to use it to track when 110V appliances turn on and off; for instance, a refrigerator's compressor. I wish to use a leg of an extension cord to sense current flow.

The data logger can be set to be triggered by a contact closure or to a pre-set voltage (three volts min). Can you design a circuit that can provide a satisfactory voltage

trigger (using a 9V battery) from a current sensor (toroid)? The sensor would have to be adjustable such that the current draw from the control circuit of the appliance will not interfere with the sensing of the compressor's current draw.

— Charlie Young

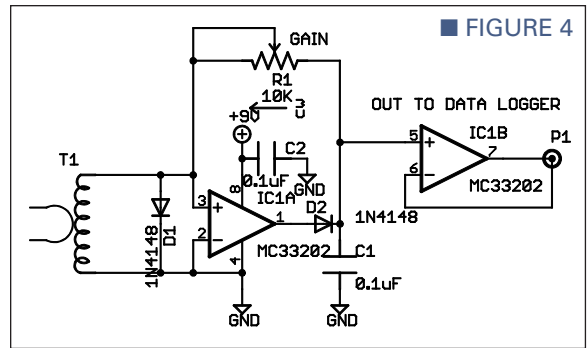

A I measured the current draw of my small freezer to be four amps; if you use a 1,000:1 transformer, the output current will be 4 mA; $4 \text{ mA} * 1K = 4V$ which is enough to trigger the data logger. Current transformers don't work well when the load is greater than 100 ohms, so I am using the input impedance of an op-amp (essentially zero ohms); see **Figure 4**. I am rectifying the output because I suspect that the data logger prefers DC input. The gain pot can be 2K or 10K, depending on the current range you expect to encounter.

Mouser part number 553-CST-1020 is rated at 20 amps and costs \$6.11.

GEL CELL CHARGING VOLTAGE

Q I have a 12V flashlight with a 12V 7AH gel battery. I need to replace the internal charging circuit. I will be using an external 12V DC supply.

What would be the recommended charging voltage

for this type of battery?

— Ken Bartone

A A lead-acid type battery is fully charged at 13.8 VDC. A 10 hour charge is recommended so the charging current should be 0.7 amps. You should measure the output voltage of your power supply because it may be high enough to charge the battery without any additional circuitry. My RadioShack power supply output is 14V no load which is adequate; I would put two or three ohms in series to limit the current. If the power supply voltage is greater than 15V, you will not be able to leave the battery connected for more than 10 hours or it will overcharge (the GEL cell has some overcharge protection, but don't depend on it). Another solution would be to plug it into the cigarette lighter socket in the car. The voltage is 13.8 VDC when the motor is running.

A boost circuit is needed to get 13.8V from a 12V source; I used National Semiconductor's WebBench (www.national.com/en/webench/)

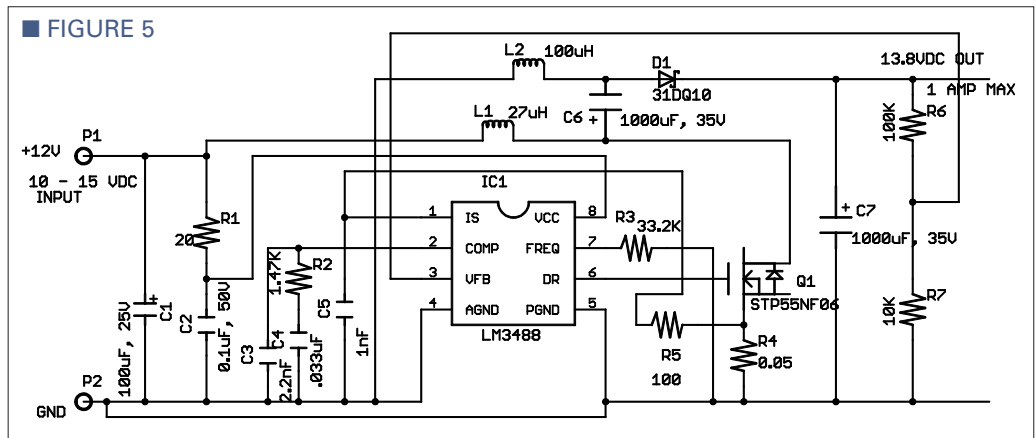



■ FIGURE 6

SEPIC PARTS LIST

PART	DESCRIPTION	PKG	PART #	PRICE
C1	100 μ F, 25V, ALUM	6.3MM	647-UPW1E101MED	0.28
C2	0.1 μ F, 50V, CERAMIC	5X3.5MM	81-RPER71H104K2P1A03	0.18
C3	2.2 nF, 50V, CERAMIC	5X3.5MM	81-RPER71222K2P1A03B	0.24
C4	.033 μ F, 50V, CERAMIC	5X3.5MM	81-RPER71333K2P1A03B	0.23
C5	1 nF, 50V, CERAMIC	5X3.5MM	81-RPER71102K2P1A03B	0.24
C6, C7	1000 μ F, 35V, ALUM	12.5x5MM	871-B41044A7108M000	0.54
L1	27 μ H, 6.4A TOROID	.86DIA	542-2100HT-270H-RC	2.61
L2	100 μ H, 4.6A TOROID	.86DIA	542-2100HT-101H-RC	2.61
D1	3A, 100V SHOTTKEY	AXIAL	844-31DQ10	1.06
R4	0.05 OHM, 5%, 1W	TO-220	652-PWR221T-30-R050J	2.60
ALL OTHER RESISTORS	1/8W, 1%			
IC1	LM3488 CUR. MODE	MSOP-8	LM3488QMMTR-ND	3.66

power.html) to design the circuit of Figure 5. National's design used all surface-mount parts but I have listed through hole parts in the parts list (except for the LM3488 which is only available as surface-mount). The part numbers in the parts list (Figure 6) are Mouser except the LM3488 is from Digi-Key. The LM3488 is also available at Newark.

This is a SEPIC design which

means that the output can be higher or lower than the input. The operating frequency is around 500 kHz, so a good layout is necessary. The LM3488 is a current mode device because the inductor current is sensed by R4 and fed to pin 1 which will shut off Q1 when the sensed voltage is 0.156. When Q1 shuts off, the energy stored in L1 is transferred to the

output through C6 and D1. L2 provides a DC path to ground. Otherwise, C6 would keep charging to higher voltage.

Voltage regulation is obtained by feeding part of the output voltage back to pin 3 which has a threshold of 1.26V. National estimates the efficiency to be 88% but they sacrificed some efficiency for size so this design should be better. **NV**

ezPick
VACUUM PICK AND PLACE SYSTEM

ABACOM TECHNOLOGIES
www.abacom-tech.com

V-MODULE Make Design Easier

- Class D Audio Amplifiers**
High Quality, High Efficiency
VMA2015 Audio Amplifier
- DC/DC Converters**
High Efficiency, No Heat Sink
VMP3201 DC/DC Converter
- FM Audio Transmitters**
HiFi Sound Quality
VMR6512 FM Transmitter
- Evaluation Boards**
Low Cost, Ready-to-Use

Features:

- All integrated design
- Ultra compact
- Almost no external parts
- Soldered by SMT or by hand
- Low cost
- High Reliability
- Many ready-to-use EVB

Applications:

- Consumer
- Auto accessories
- Instruments
- Industry
- Toys
- Communication Equipments
- And many more

Dealer Wanted!
 URI: <http://www.v-module.com>
 Email: sales@v-module.com
 Tel: +8610 82562708
 Fax: +8610 82562707

SHOWCASE

Recycling & Remarketing High Technology

WEIRDSTUFF WAREHOUSE

Software, Computers, Electronics, Equipment, Doohickies

WE BUY/SELL EXCESS & OBSOLETE INVENTORIES
FREE COMPUTER AND ELECTRONIC RECYCLING
GIANT 10,000 SQ. FT. AS-IS SECTION

**384 W. Caribbean Dr.
Sunnyvale, CA 94089**
Mon-Sat: 9:30-6:00 Sun: 11:00-5:00
(408)743-5650 Store x324
WWW.WEIRDSTUFF.COM

Wireless Robotics Controller

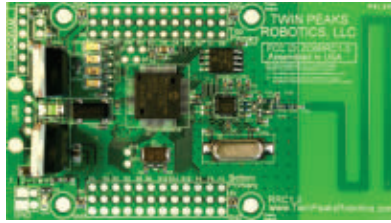

915 MHz Radio (FCC Part 15.249)
16 MIPS Microchip PIC24 CPU
24 Configurable I/O Ports with Power
USB Master, 1 Mbit EEPROM, Real Time Clock

www.TwinPeaksRobotics.com

NKC ELECTRONICS

Zeroplus LAP-C 16032 Logic Analyzer
16-channel - 100MHz - USB 2.0
SPI - I2C - UART - 7-segment
2 free additional protocols

\$120

Arduino UNO \$29.95

Open Source Hardware
Arduino UNO - MEGA 2560
Arduino Duemilanove \$24.95
Freeduino - Seeeduino
DSO Nano
Arduino Shields - Ethernet
RGB LCD - XBee

Rigol DS1052E DSO
50MHz - up to 1GSa/s
1 Meg mem - TFT LCD - USB
Advanced triggering: Edge,
Pulse, Video, Slope, Alt

Special \$399

<http://www.NKCElectronics.com>

QKITS.COM

Power Supply: 12/24VDC Load Voltage

30A PWM DC Motor Speed Control
Control the speed of your electric motors or the brightness of your DC light bulbs.

\$24.95

Quantity discounts available.
1-888-60-4-KITS

www.Primecell.com

Battery rebuilding service

Dead Batteries? Don't toss them. Send them to us - our rebuilds are better than original specifications.

Tools
Hilti Skil Milwaukee Panasonic B&D DeWalt Makita All 2-36 Volts

Electronics
Bar Code Scanners Surveying Printers Laptops Photography

Radios
APELCO UNIDEN G.E. ICOM KENWOOD MOTOROLA MIDLAND MAXON YAESU ALINCO

Visit www.primecell.com for important details
24 Hr Secure recorder tel-fax (814) 623 7000
Quotes email: info@primecell.com
Cumard Assoc. Inc. 9343 US RT 220 Bedford PA 15522

BlinkM

Arduino

I2C RGB Smart LED USB - BT - XBEE

Prototyping Supplies

Serial LCD

Save 5% with coupon code NV

FunGizmos.com

Build Your Own:

THEREMIN

Theremax
The Ultimate Theremin

paia.com Music/Tutorials/Kits Analog Synthesizers Guitar Effects Tube Electronics Studio Gear

PAIA
Makers since 1959

CHIPINO

The Arduino Style Module for the Microchip PIC User

\$19.95 kit
\$29.95 assembled

WWW.CHIPAXE.COM

SDPSI sdp-si.com
800-819-8900

FREE CATALOG

Small Mechanical Components
SETTING IDEAS INTO MOTION

Nuts & Volts 7 CD-ROMs & Hat Special!

Complete with supporting code and media files.

NUTS VOLTS 2010 Volume 31, No. 1-12
NUTS VOLTS 2009 Volume 30, No. 1-12
NUTS VOLTS 2008 Volume 29, No. 1-12
NUTS VOLTS 2007 Volume 28, No. 1-12
NUTS VOLTS 2006 Volume 27, No. 1-12
NUTS VOLTS 2005 Volume 26, No. 1-12
NUTS VOLTS 2004 Volume 25, No. 1-12

Only \$149.95
www.nutsvolts.com

Free Shipping!

NEW

- HARDWARE
- SOFTWARE
- GADGETS
- TOOLS

PRODUCTS

BASIC ON BOARD

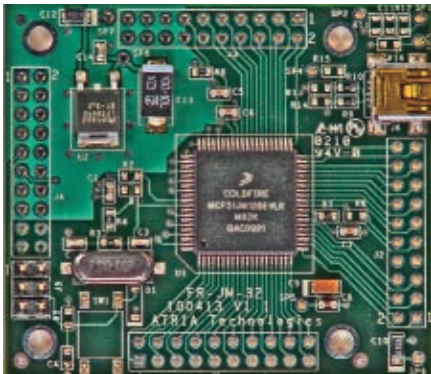

BASIC ON BOARD is a Basic interpreter that is preprogrammed on many of the ForeRunner microcontroller modules from ATRIA Technologies. BASIC ON BOARD is a derivative of the popular StickOS™ Basic developed by software engineer Richard Testardi.

BASIC ON BOARD is a perfect tool to learn programming, explore microcontrollers, design prototypes, build home projects, and even small products. To get started, all you need is a terminal emulator. BASIC ON BOARD enables access to many of the features of a microcontroller using built-in commands, pin, and register variables.

- Write text to a display: lcd 1, "Hello World."
- Read a 4x4 keypad: on keychar do gosub KYPD.
- Create a timer interrupt: on timer 1 do gosub clock.
- Write to an I²C device: i2c start 0x68, i2c write t, i2c stop.

Common features such as console I/O and string handling are available. With the HD44780 interface, a character LCD can be directly controlled with a single command. A 4 x 4 keypad may be

read as an interrupt. Developing programs is easy — type it in and run it. ForeRunner microcontroller modules with BASIC ON BOARD start at \$24.

For more information, contact:
ATRIA Technologies, Inc.
PO Box 896
Webster, NY 14580
Tel: **585-671-4390**
Web:
www.AtriaTechnologies.com

THE MODEL PRO-50A

Global Specialties has just re-introduced a new low cost, high quality, three year Digital DMM.

The Model PRO-50A has a number of features and functions not offered by any similarly priced products on the market today.

The Model PRO-50A is a highly versatile, economically priced, hand-held digital multimeter. Designed to meet CAT III (1,000V) and CAT IV (600V) safety standards, engineers, technicians, electricians, and students can use the PRO-50A in confidence with its rugged design and non-contact AC voltage (NCV) detection feature. The PRO-50A has a large 3-1/2" digit LCD backlit display for comfortable viewing. The PRO-50A — fused and fully overload protected — is housed in a protective rubber boot and is multi-functional and capable of measuring voltage, resistance, amperage, capacitance, frequency, transistors, and temperature.



For more information, contact:
Global Specialties
Tel: **800-572-1028**
Web:
www.globalspecialties.com

SirMORPH IR SENSOR



Mikronauts has just released the SirMorph — a versatile IR sensor for robotics and industrial use. (SirMorph is featured in the "Upgrading the Boe-Bot" series in the September/October issues of *SERVO Magazine*.) SirMorph is designed to be used for/as:

- Short range distance measurement (2-40 mm to 2-150 mm, depending on LED drive current).
- Servo mounted wheel encoder for Solarbotics wheels.
- Virtual bumper.
- Line sensor when mounted facing down.

A pair of SirMorps can even be used as a combination servo mount, wheel encoder, and side virtual bumper. SirMorph can be configured for different uses and ranges simply by using different resistor values for the IR LED current limiting resistor. The product documentation includes a table of suggested resistor values with their current draw and

approximate detection range. The default configuration is 11 mA at 5 VDC. SirMorph is available now both as a kit and as assembled and tested sensors. Reseller and bulk educational discounts are available.

ROBOAXE AND SCOOTER



RoboAxe DC Motor Edition.

Scooter prototype with RoboProp advanced controller and ultrasonic range sensor head.



Mikronauts also introduces RoboAxe and Scooter. RoboAxe is an intermediate level robot controller board based on the PICAXE 20m2 processor with an optional dual DC motor driver and two generous prototyping areas matching the layout of the optional dual 170 point solderless breadboards. RoboAxe was designed to meet the needs of the educational market, making it ideal for use in developing STEM educational courses, FIRST competitions, and it can be used as a platform when trying for the new Boy Scouts of America robotics merit badge. The nature of the resulting design also meets the need of robotics enthusiasts and hobbyists for an affordable intermediate level controller. Some of RoboAxe's many features include:

- PICAXE 20m2 microcontroller.
- Free Basic development environment and books are available from PICAXE.
- 4.00" x 3.05" inch high quality printed circuit board with mounting hole; pattern matches other Mikronauts (and Parallax) boards.
- Two large prototyping areas with matching optional solderless breadboards.
- Standard DB9F connector for serial programming.
- Optional USB-serial programming cable.
- 5V voltage regulation.

- Reverse battery voltage protection diode.
- Two solderless breadboards with 170 holes each.

Some of Scooter the Robot features include:

- RoboAxe DC Motor edition.
- Two solderless breadboards.
- Five SirMorph sensors for virtual bumpers and line following.
- Blue Magician chassis.
- Two gear motors.
- Two yellow wheels with black tires.

- Optional ultrasonic scanning sensor head with servo.
- Optional infrared scanning sensor head with servo.

RoboAxe and Scooter are also available now. Reseller and bulk educational discounts are available.

For more information, contact:
Mikronauts
 Email: mikronauts@gmail.com
 Web:
<http://mikronauts.com/sirmorph>

\$51^{For 3} PCBs

FREE Layout Software!

FREE Schematic Software!

01 DOWNLOAD our free CAD software

02 DESIGN your two or four layer PC board

03 SEND us your design with just a click

04 RECEIVE top quality boards in just days

expresspcb.com

WEB BROWSER CONTROL OF YOUR HOME

THERMOSTAT

Part 2

By Jürgen G. Schmidt

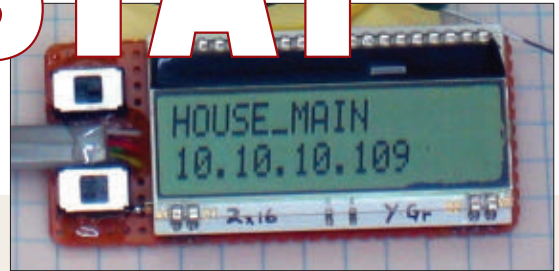

Last month, I described the basic hardware for implementing a thermostat with an embedded web server so it can be controlled from a browser. This consists of a TCP/IP Base board using a Microchip 16-bit PIC24 processor to provide a general-purpose web server, with a daughterboard that implements the thermostat hardware and interface to the home heating, ventilation, and air conditioning (HVAC) equipment. In this article, I will describe the physical connections, some construction details, and the software that makes it all work.

Network, Power, and HVAC Connections

While I had the foresight to install CAT-5 cable to the thermostats when I built my house, I did not run any power lines. I assumed at the time that I would get power from the thermostat itself. Alas, while some thermostats have a fifth wire to provide power, mine did not. Instead, power for the new thermostat is provided via the unused pairs of the CAT-5 networking cable. Only pins 1, 2, 3, and 6 are used for the network connection. If you look at the Wikipedia article on CAT-5 wiring (see [References](#)), you will see there are two ways to arrange the wires in the connectors. I used the T568B arrangement, since that

matched my existing cables. The Wikipedia article on Power over Ethernet shows which wires to use for the power connection. The table at the end of that article shows that pins 4 and 5 are used for the positive terminal and pins 7 and 8 are used for the negative terminal.

When I made my cables, I separated the wires and fed only the network-related pairs into the RJ45 connectors and soldered the other pairs to coaxial 2.1 mm power connectors. To verify that I had everything figured out correctly, I made a short test cable, the two ends of which are shown in [Figure 1](#).

The red connector mounts on my patch panel, from which it is connected via a jumper to my network switch. A regulated five volt power supply plugs into the 2.1 mm jack. The male RJ-45 connector and the 2.1 mm plug connect to the TCP/IP base board. The live thermostat end of this can be seen in [Figure 2](#).

The green connector coming out of the wall is attached to the HVAC control cable. This is a Phoenix pluggable terminal block that plugs onto a header on the thermostat board (**J1** on the circuit diagram). These connectors are handy because they can be oriented three different ways when plugged into the header and are convenient for testing and installation. If you mount screw terminals directly on the thermostat board, you have to juggle the thermostat, screwdriver, and cable while you attach and detach the wires. Instead, you attach the terminal block directly to the cable and then plug and unplug as needed.

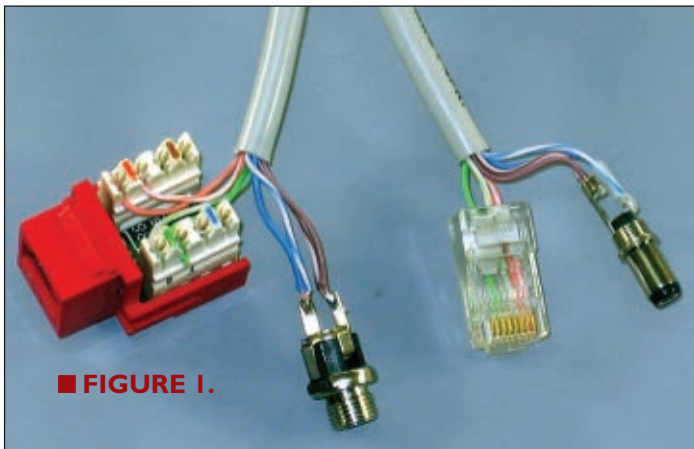

■ FIGURE 1.

Construction Issues

Eventually, the thermostat would be mounted in an enclosure and attached to the wall in place of the original thermostat. To simplify the overall assembly, I wanted to limit the connections to the circuit boards to power, network, and HVAC control. All the switches, the display, and connectors should be on the circuit boards. Finding the right switches was a challenge, along with mounting the LCD so that everything could be mounted at the right height behind and through the faceplate. The connectors between the circuit boards needed to be the right length to leave just enough clearance for the MagJack.

Plastic enclosures do not come in an infinite array of sizes and colors. The BUD CU-389 enclosure was just the right size but only available in black. After drilling the ventilation holes in the base, I spray-painted it off-white to match the walls. I custom-made my own faceplates from some scrap plastic. You can see these in **Figure 3**. The translucent gray cover is made from acrylic and the almond colored cover is made from an old ABS plastic enclosure. These were made on a ZenBot CNC router. The routed lettering is filled in with oil pastel.

Some of the components for this project are only available in surface-mount (SMD) format. That and size limitations dictated a SMD implementation for all but the connectors, LCD, relays, and switches. Some of the connectors are available in SMD format, but I prefer to use the through-hole version for mechanical sturdiness. This was my largest SMD project to date. I've used a fine-tipped soldering iron in the past, but for this project I decided to invest in a compressed air-powered solder paste dispenser and got a convection toaster oven to use as a reflow oven.

Initially, I used a thermocouple attached to my multimeter to monitor the oven temperature, but now I do so much surface-mount work that I built an automated reflow oven controller, based on the thermostat daughterboard. It provides the display, pushbuttons, and relay driver. (See the **sidebar**: Flexible Designs.) My website – www.jgscraft.com – has additional information about my surface-mount soldering process and how these boards were made.

Everything worked well, including soldering some of the bypass capacitors on the underside of the TCP/IP board. I moved these to the back to reduce clutter on the top of the PCB. As the flux heats up, there is enough surface tension to hold the parts in place, so only a single baking cycle is needed. I used 805-sized components for the resistors, LEDs, and most of the capacitors. The bypass 0.1 μf capacitors are 603s.

After baking the boards, the only cleanup I needed to do was around the PIC 44-pin TQFP part. There were some solder bridges that were easy to fix by running a fine-tipped soldering iron between the leads. The corollary to solder bridges is unsoldered pins which again can be fixed with a fine-tipped soldering iron and .025 inch solder. I test all the connections on the multi-

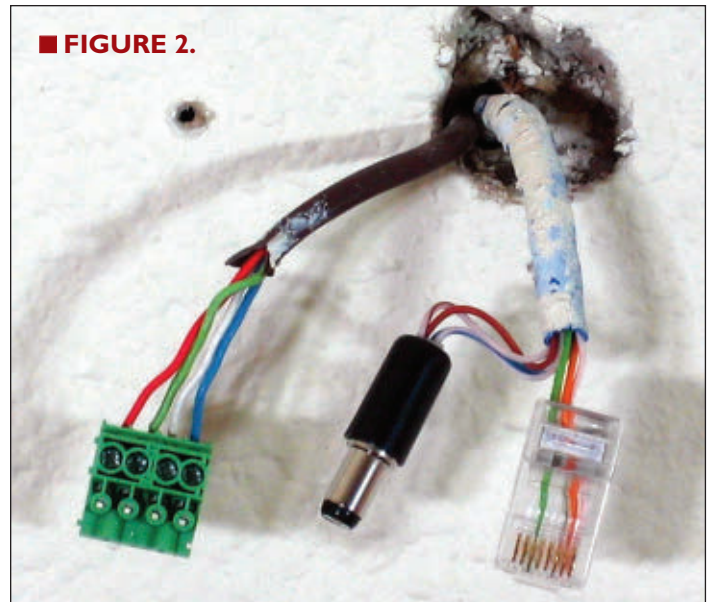

■ FIGURE 2.

pin parts for shorts and opens just to avoid headaches later on.

For the fine-pitched parts, there is a fine line between applying enough solder paste to avoid dry connections and too much that results in bridged connections. I also found that some parts had slightly bent pins that did not make contact with their pads, so now I check the parts on the flat side of an old CPU heatsink to be sure all the pins touch the surface.

Software

Developing the software for the thermostat requires Microchip's C30 compiler which is now called "MPLAB C Compiler for PIC24 MCUs" and the TCP/IP stack version 5.25 (or later) which is part of the Microchip Application Libraries. You also need the MPLAB IDE to manage the project and its many files. The student or demo version of

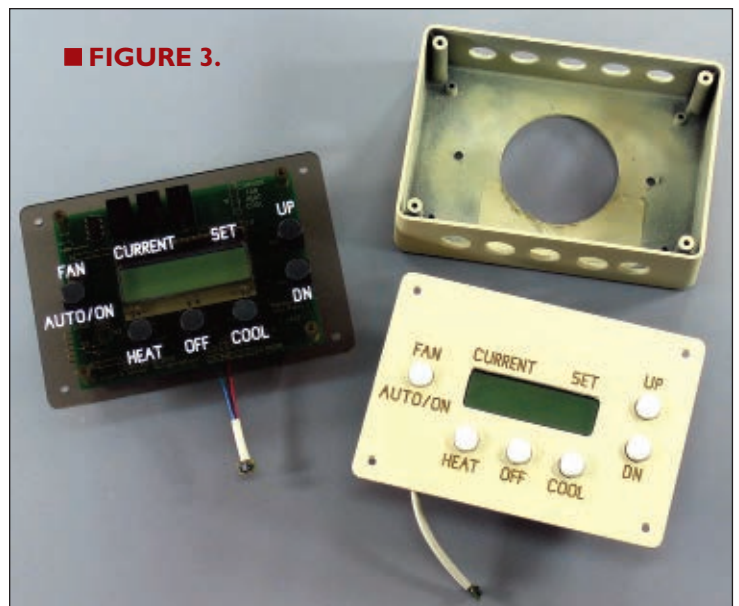

■ FIGURE 3.

Flexible Designs

The initial design work for the browser-controlled thermostat started out as a single, monolithic circuit and board design. Space limitations suggested a double-decker design which led to a separation of functions. This ultimately led to the design of two boards which could be applied to much more than just a thermostat application.

I isolated the hardware for the network connection and embedded webserver on one board and added some additional support circuitry to make it more flexible. The original design using a 28-pin processor had just enough I/O pins to support the thermostat application. Switching to a 44-pin part allows flexibility with other applications. I was able to develop the TCP/IP stack, bootloader, and webserver software without needing the thermostat board. All the unused I/O lines, power, and UART2 connections are available on PCB pads that will support standard 0.1" pitch headers.

The thermostat interface board has an LCD, some pushbuttons, relay driver circuitry, and some relays. Many of the projects I have seen in *Nuts & Volts* have similar interface requirements. The board does have dedicated circuitry for

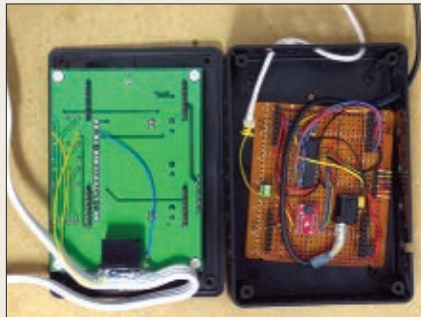

attaching the temperature and humidity sensors. However, these — as well as all the other connections — are just links via headers to I/O lines on the processor — they could be connected to anything.

There are lots of projects in my backlog that need a browser interface to hardware systems. The TCP/IP base board will work well for those. Other projects require a display and pushbutton interface. I have already repurposed one of the thermostat daughterboards as a reflow oven controller. Instead of the two-line LCD, I used a three-line version from the same manufacturer. I only needed one heavy-duty relay and three of the pushbuttons. The headers attach to a perfboard that mounts the PIC16F690 controller I used for this, a thermocouple interface, and power regulator. All of this I mounted in the same enclosure I used for the thermostat. I just deleted some of the holes from the existing CNC router program to give me the right faceplate. The results can be seen in the photos.

The added benefit of flexible designs is that I make use of the extra PCBs I end up with. Some boards I order have design errors, but if the design is flexible, they can still be used for other projects. Even for the final boards there is usually a minimum area per order, resulting in extra boards. Ideally I would sell them, but if I can't, I will eventually find another use for them.

the C30 compiler works fine, so all your software development tools are free. The TCP/IP stack is fairly easy to use, provided you know the basics of the TCP/IP protocols and you read the documentation for the stack. Studying the source code and posts on the Microchip forums related to Ethernet and the processor family you are using is also a good idea. The forums are well supported and provide a wealth of information that might be hard to find elsewhere.

The first step in using the stack is to take one of Microchip's sample applications as a starting point and modify it for your hardware. This is usually the "TCP/IP Demo App" and is referred to regularly in forum postings. This implements a webserver, as well as most of the common TCP/IP components such as UDP, TCP, Client/Server, email, DHCP, and more. The Demo App is configured to run on Microchip's evaluation and demonstration boards but modifications to the hardware configuration files will adapt it to run with your own TCP/IP hardware or — in this case — the thermostat project. The TCP/IP base board comes with detailed instructions for configuring Microchip's TCP/IP stack version 5.31 to run the Demo App.

This is not my first embedded TCP/IP project and I don't recommend anyone start a project like this from scratch. Get a development kit from Microchip or other hardware that comes with working software and start experimenting from there. I started out working with TCP/IP on a small development board, a sample application, and a series of tutorials that were known to work. Over time, my software and hardware evolved from this in gradual steps. If something failed, I could go back a step to find out if the software or the hardware was at

fault. One incorrectly assigned pin in the software or one loose solder joint is all it takes to hang up the system, and it's hard to tell if hardware or software is the culprit. So, before adding my own code, I make sure any new hardware will work with the demo application.

The files that typically need to be modified are `HardwareProfile.h` and `TCPIPConfig.h`. For the TCP/IP base board, I also needed to modify `ENC28J60.c` to enable the clockout signal that drives the CPU clock. The `main.c` file contains some hardware initialization routines that need to be modified to match the hardware, as well. Once the board tests okay for the basic TCP/IP applications, I can add support modules for any additional hardware. Then, I add modules to `main.c` for my specific application.

The HVAC control software consists of a loop that: 1) Pauses a while and checks the system clock to see if certain timeout events have occurred; 2) Reads the sensor(s) and updates variables with the results; 3) Checks if a button has been pressed and updates variables corresponding to the thermostat settings; 4) Checks to see if any of the relays need to be turned on or off; and 5) Updates the display. There is no rocket science here, but there is a control detail that needs attention.

If a heater is set to turn on when the temperature gets below 60 degrees F, it will do so when the sensor is at that temperature. However, once the sensor is at 60 or above again, the heater will turn off and when the temperature falls again, the heater will turn on. This can result in the heater trying to turn on and off rapidly as the temperature fluctuates. To avoid this, we include a dead-band or hysteresis into the control loop.

Once the heater turns on, it will not turn off again until the heat is a certain amount, maybe one degree

```

switch( myAppState )
{
case smMY_IDLE:           //----- don't work too hard -----
  //-- check if we need to turn off backlight
  if( TickGet() - ticks3 >= TICK_SECOND * 5UL ) LEDB_OFF();

  //-- check if we need to turn off alternate LCD display
  if( TickGet() - ticks4 >= TICK_SECOND * 3UL ) showLCD = LCD_MAIN;

  if( TickGet() - ticks1 >= TICK_SECOND/20ul )
  {
    ticks1 = TickGet();
    myAppState = smMY_STEP1;
  }
  break;

case smMY_STEP1:         //----- get temp and humidity -----
  //-- get temp and humidity periodically
  if( TickGet() - ticks2 >= TICK_MINUTE/12ul )
  {
    ticks2 = TickGet();
    sht_rd(&tempC, &humidity);      // SHT11 library
  }
  humidity = (int)(humidity);      // round to integer value
  tempF = (int)(tempC * 9 / 5 + 32);
  myAppState = smMY_STEP2;
  break;

case smMY_STEP2:         //----- check for button press -----
  .
  .
  .
  myAppState = smMY_STEP3;
  break;

case smMY_STEP3:         //----- check if we need to turn anything on or off
  .
  .
  .
  myAppState = smMY_STEP9;
  break;

case smMY_STEP9:         //----- check for any configuration changes and save them
  .
  .
  .
  myAppState = smMY_IDLE;
  break;
} //switch( myAppState )

```

■ LISTING 2.

```

while( 1 )
{
  switch( smSysState )
  {
    //----- begin of main TCP/IP processing loop -----

    case RUN_IDLE:
      //-- toggle heartbeat LED
      if( TickGet() - t1 >= TICK_SECOND/2ul )
      {
        t1 = TickGet();
        LED1_IO ^= 1;
      }
      smSysState = RUN_NET_TASKS;
      break;

    case RUN_NET_TASKS:
      StackTask();           // HTTPServer runs here as another state machine
      smSysState = RUN_NET_APPS;
      break;

    case RUN_NET_APPS:
      StackApplications();
      smSysState = RUN_MY_APPS;
      break;

    case RUN_MY_APPS:
      MyTasks();
      smSysState = RUN_UPDATES;
      break;

    case RUN_UPDATES:
      if( AppConfig.MyIPAddr.Val != eth0_ip_addr )
      {
        eth0_ip_addr = AppConfig.MyIPAddr.Val;
        IPAddressToString( &AppConfig.MyIPAddr, buffer);
        printf("New IP Address = %s\n\r", buffer);
        #if defined(STACK_USE_ANNOUNCE)
          AnnounceIP();
        #endif
      }
      smSysState = RUN_IDLE;
      break;

    //----- end of main processing loop -----
    //-----

    case SYS_ERROR:
      printf("ERROR STATE\n\r");
      while(1);

    case SYS_RESET:
      printf("%s System Reset\n\r", PRODUCT_NAME);
      Reset();

  } //switch( smSysState )
} //while( 1 )

```

■ LISTING 1.

higher than the set point; in this case, 61 degrees. This temperature difference is the dead-band in which no changes will take place. In the thermostat software, there is a dead-band of two degrees Fahrenheit. The heater will turn on at one degree below the set point and will turn off at one degree above the set point. You can see the details of this in the thermostat.c file that is included with this article's downloads.

Multitasking

For a webserver to work properly, the TCP/IP software needs to monitor the network connection for incoming traffic. While the incoming data is processed, it still needs to continue checking for incoming data so none is lost. In order to accomplish this, the TCP/IP stack is implemented as a series of nested loops. Each of these loops has multiple steps in it. Each step performs a little bit of work, exits the loop to let the outer loop do a little work, and then the inner loop resumes with the next little step, exits, and so on. This is called "cooperative multitasking" and is described in detail in the TCP/IP stack documentation. This is important in the context of the thermostat application because it must also follow this pattern. **Listing 1** shows the case statement that runs the TCP/IP stack in the demo application. This is running in an infinite while() loop. The blue code highlights where the user application, MyTasks(), has been added. This gets called every fifth time through the loop.

The MyTasks() function in the file thermostat.c implements the thermostat as described above and is

shown in abbreviated form in **Listing 2**. Whenever it is called, the state variable, myAppState, is checked and the corresponding portion of the case statement is processed. Then, the state variable is updated with the next value and the function exits to allow the main loop to do some work. Five iterations of the main loop later, we're back in MyTasks() to process the next section of code, and so on. The application programmer is responsible for making sure nothing is interrupted for long – or worse – blocked while waiting for something to happen such as a button press or serial communication.

The Embedded WebServer

The usual software process for microcontroller development involves compiling a program, loading the HEX file, and testing the result. With an embedded webserver, there are some additional steps. You need to develop the web pages you want displayed and then you need to load them onto the server.

Web pages for the TCP/IP stack are created just like any other website. You can include pictures, JavaScript, CSS, and any other files that your target browser will support. The webserver stores the files in the serial Flash memory, up to four megabytes worth. The primary job of the webserver is to just deliver the files to the browser. Dynamic variables in the web files will be filled in by the

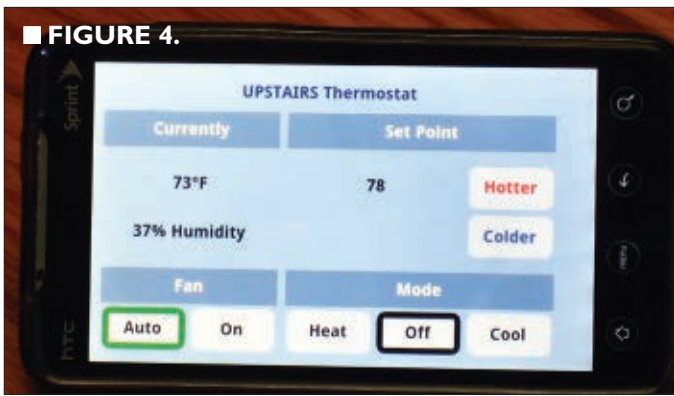

■ FIGURE 4.

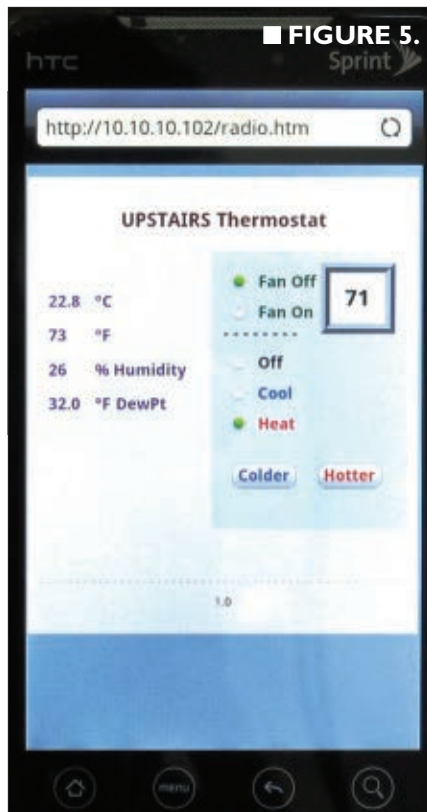

■ FIGURE 5.

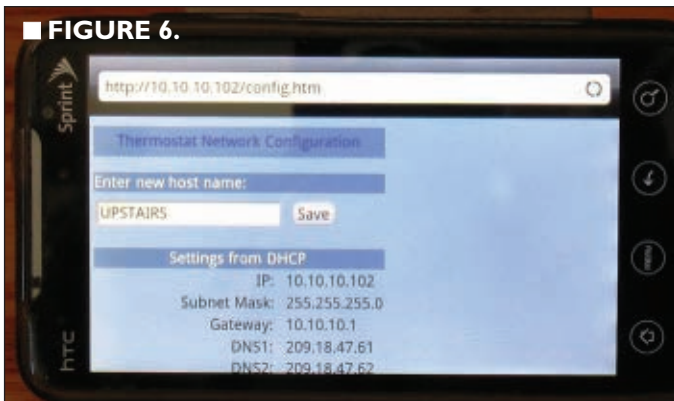

■ FIGURE 6.

webserver before the files are sent to the browser. This is fine for relatively static content, but for an interactive application such as a thermostat, we need something more. We want to be able to see the temperature change without having to hit the refresh button on the browser. This is accomplished via an AJAX interface.

AJAX is basically a library of JavaScript functions that leverage certain browser features for interactive applications. The AJAX routines communicate with the corresponding functions in CustomHTTPApp.c which is part of the TCP/IP stack. A detailed explanation of how this works would take at least another article on its own. For now, you'll have to settle for reading about it in the documentation and sample code from Microchip. The JavaScript code runs in the user's browser, periodically sending updates from the web page to the webserver and retrieving data from the webserver for updating the browser display.

the webserver for updates so that the web page is kept current. That will happen if the decrease pushbutton on the physical thermostat is pressed. The set point value is decremented and displayed on the LCD. The JavaScript code will retrieve the updated value for display on the web page.

The web page design can be changed and uploaded to the webserver without making any changes to the application code. The only time you would need to change the application and recompile it is if you want to exchange more data between the web page and the application. If you don't like the way the thermostat web page is laid out, change it and upload it using the MPFS2.EXE utility. You can even add additional pages, as long as they fit into the memory.

Figure 4 shows the default thermostat page. **Figure 5** shows an alternative page that is accessed by changing the web address. **Figure 6** shows a configuration page that

changes the host name for the thermostat. Most computer-based browsers allow you to access the web page by the host name. Unfortunately, the browser on my EVO doesn't do that and I have to type in the IP address and save it as a bookmark.

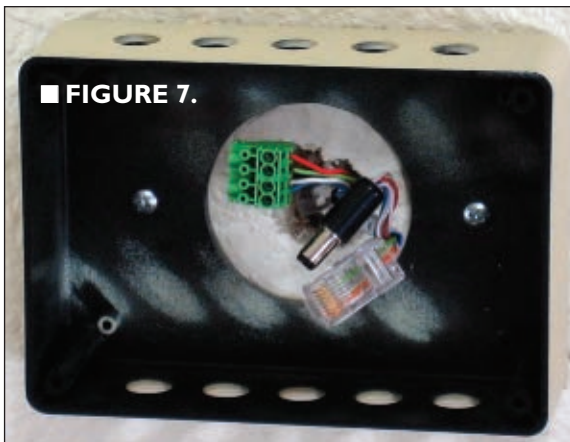

■ FIGURE 7.

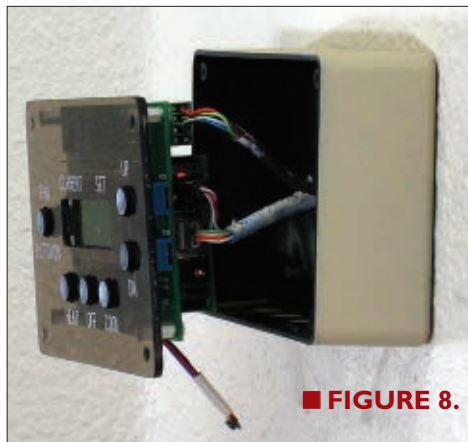

■ FIGURE 8.

Installation

The hardest part of

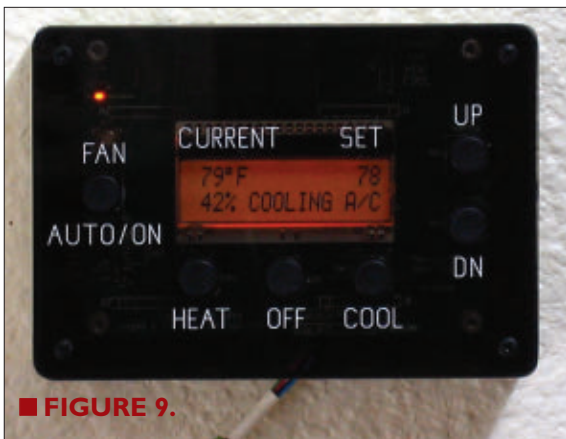

■ FIGURE 9.

The heartbeat LED should blink once per second and the LCD should display the current status.

Test the various buttons to be sure they change something. If you did not connect a terminal to see the debug output, you can press the “UP” and “DN” buttons at the same time to display the IP address and host name. If all this is working, connect the

the installation is probably arranging for a network cable to come out where you plan to mount the physical thermostat. In most cases, that should be a matter of dropping the cable down inside the wall from the attic or feeding it up from the basement or crawl space. Attach the connectors as described in Wikipedia articles and here.

You do need a DHCP server on your network to provide the thermostat with an IP address. Most cable or DSL routers provide this by default. Disconnect the old thermostat from the wall and identify the function of the wires. The diagram at <http://wiki.xtronics.com/index.php/Image:Thermostat.gif> should help you in identifying them if it's not obvious. Connect the thermostat wires to the Phoenix terminal block in the sequence shown on the thermostat PCB. For now, connect only the network cable and power.

thermostat connector, making sure it is oriented correctly.

Sequencing the final assembly of the pieces on the wall was a puzzle in itself. The enclosure needs to be attached to the wall. Wires need to be plugged in. The PCB assembly needs to be mounted in the enclosure and then the faceplate goes on. After playing with some mockups, I decided to attach the thermostat daughterboard to the faceplate with some standoffs. The TCP/IP base is socketed to the daughterboard, held firmly in place by the four eight-pin headers.

After plugging in all the connectors, you can attach the faceplate to the enclosure that has already been attached to the wall. It's a tight fit so you need to be sure you can push any excess wire into the wall. **Figures 7, 8, and 9** show this sequence. You are now ready to control your thermostat from your recliner. **NV**

REFERENCES

CAT-5 Wiring
<http://en.wikipedia.org/wiki/Cat-5>

Power Over Ethernet
http://en.wikipedia.org/wiki/Power_over_Ethernet

ZenBot CNC Router
www.zenbotcnc.com

Hysteresis Explained
http://wiki.xtronics.com/index.php/Dead-band_hysteresis

AJAX
http://en.wikipedia.org/wiki/Ajax_%28programming%29

Thermostat Circuit
<http://wiki.xtronics.com/index.php/Image:Thermostat.gif>

Brush Electronics
<http://brushelectronics.com/>

Microchip Application Libraries
www.microchip.com/mal

Microchip Bootloader Application Note
<http://ww1.microchip.com/downloads/en/AppNotes/01094a.pdf>

You can contact me at jurgen@jgscraft.com.

An easier, more reliable way to 'cut the wire!'



Ready for wireless but unsure about the best path? Anaren Integrated Radio (AIR) modules offer:

- > Industry's easiest, most cost-effective RF implementation
- > Low-power RF solution
- > Virtually no RF engineering experience necessary
- > Tiny, common footprints
- > Pre-certified/compliant: FCC, IC, ETSI (as applicable)
- > Choice of modules based on TI CC11xx and CC25xx, low-power RF chips: 433MHz, 868MHz (Europe), 900MHz, 2.4GHz

To learn more, write AIR@anaren.com, visit www.anaren.com/air, or scan the QR code with your smart phone.

ONLY \$999 FOR 10K OR MORE!



Anaren
What'll we think of next?®

800-411-6596
www.anaren.com
In Europe, call +44-2392-232392

Available from:





BUILD THE LED CENTERPIECE CHRISTMAS TREE



Since the time candles were first used for decorating Christmas trees, a well-lit tree has always been an important part of the holiday season. The Christmas tree described here makes a great table centerpiece, or with a simple modification can be used in a front yard display that your neighbors will envy! If you have read the previous articles in *Nuts & Volts*, you have been introduced to the Spectrum-ACE family of single board controllers with the ALEC® operating system. (If not, check out the March '11, April '11, and July '11 issues because this article specifies these platforms exclusively.)

To help get into the holiday spirit, this will be a project that everyone can enjoy. Using either the Spectrum-Lite or the Spectrum-ACE 2a, we are going to build our Christmas tree from LEDs. Once that's done, we will show you how to easily modify the design to run traditional 110 volt AC strings of lights. This little tree has 20 different routines controlling 256 LEDs and will bring non-stop enjoyment to your holiday season. First up, let's talk about the control hardware for the tree.

To make it easy for everyone to build, the main hardware can go in one of two directions. The first version of the hardware is the simplest way. Using the Spectrum-

Lite CPU with a small evaluation PCB (printed circuit board), all we add are two ULN2003a seven-channel low side N channel FET drivers, two 2N7000 N channel FETS, four NPN transistors, and a handful of resistors.

As seen in **Photo 1**, the hardware is very straightforward and can easily be built-up in an hour or two. During testing, a simple hand-wired board was added with a few LEDs to display what the software is doing. The **Parts List** for the Spectrum-Lite version is shown later in the article.

So, let's get down to it and have some fun. First, let's take a closer look at the schematic shown in **Figure 1**.

The Spectrum-Lite has one dedicated UART, a real time clock, and 20 general-purpose I/O (GPIO) lines, which is great because for our Christmas tree we need — you guessed it — 20 I/O lines. As can be seen in the schematic, 16 I/O lines are used to drive the 16 FETs for 16 common lines of the tree and four I/O lines are used for color selection on each of the 16 strings that make up the tree. The proto area on the small evaluation board has plenty of area to support all the circuitry and more.

■ PHOTO 1.

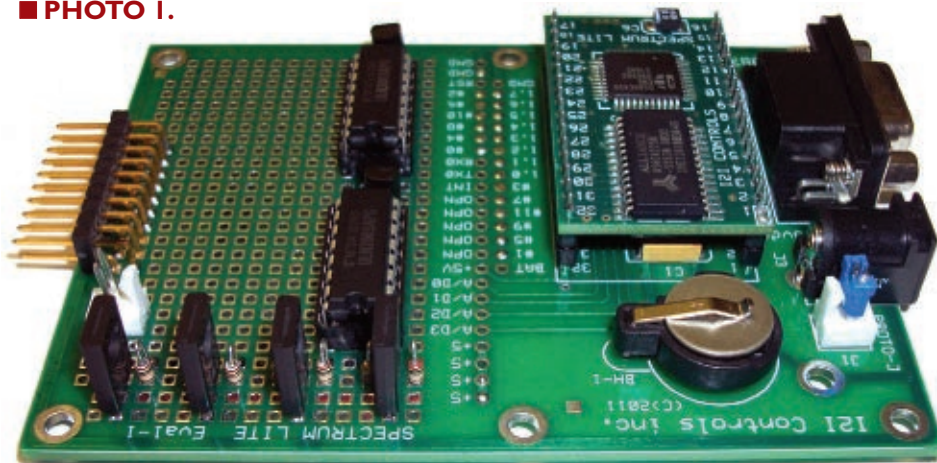

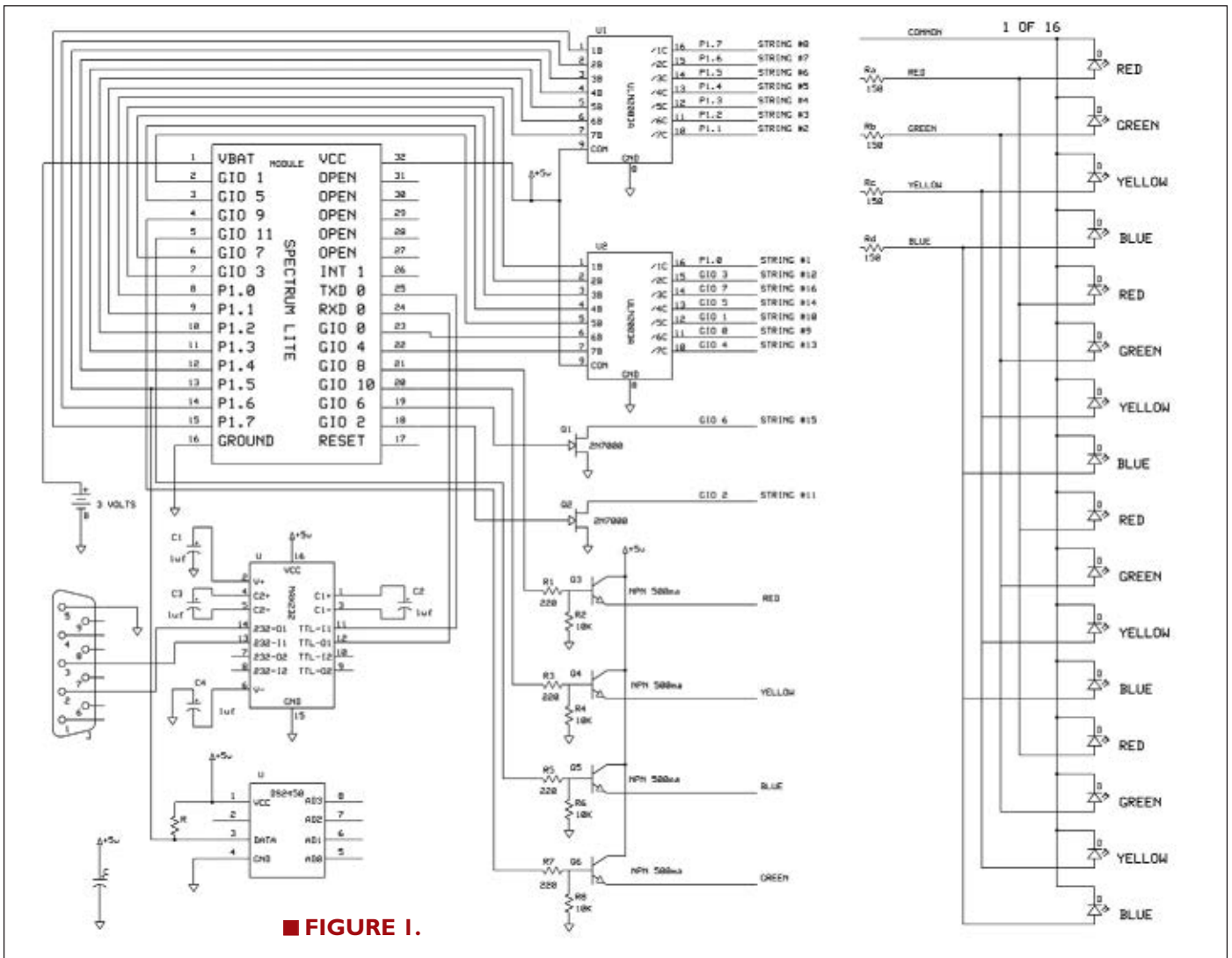

■ FIGURE 1.

The evaluation board also has a DS2450 A/D (analog-to-digital) converter open if the user wants to take advantage of it. Port 1 of the CPU is used to control strings 1 through 8 (spokes 0-7). The lower eight GPIO lines of the real time clock control strings 9 through 16 (spokes 8-15), with the last four GPIO lines controlling the color of the tree. The control of the strings of lights is done in a simple matrix type of format. To turn on a string of lights, select the appropriate I/O line for the string, set it high, select the color control I/O line, set it high, and away we go! Once you have your hardware up and running, it is very easy to write your own routines and add to the library of routines in the main program.

The second version of the hardware uses the Spectrum-ACE 2a with the addition of a 20-key keypad (the keypad shown here was just one out of the junk box), a four line 20 character LCD, a USB drive, and the option for a Maxim™ 7301 I/O expander for even more lighting control. Even with these additions, this is still a project that can easily be up and running for this holiday season. At the core of both designs, the control of the tree is the same. This way, you can start with a simple design to get it

up and running, and then go all out and really impress friends and family. For a complete schematic of the expanded hardware version, you can visit our website at www.i2icontrols.com and download it. It is also included

PARTS LIST

QTY	ITEM
1	Spectrum-Lite CPU module
1	Small evaluation board for Spectrum-Lite
2	ULN2003A Darlington transistor arrays
2	2N7000 N channel FETs
4	NPN transistors (any NPN will work, but must be good for 500 ma of current)
4	220 ohm 1/8 watt resistors
4	10K ohm 1/8 watt resistors
64	150 ohm 1/8 watt resistors
64	Red LEDs
64	Green LEDs
64	Yellow LEDs
64	Blue LEDs
8	36 inch lengths of 1/16 inch brass rod
	160 inches of 1/16 inch black heat shrink
	36 feet of multi-color four-conductor wire with ground
	For 110 volt AC operation, the I2I Controls four-channel AC switch is available.

■ PHOTO 2.

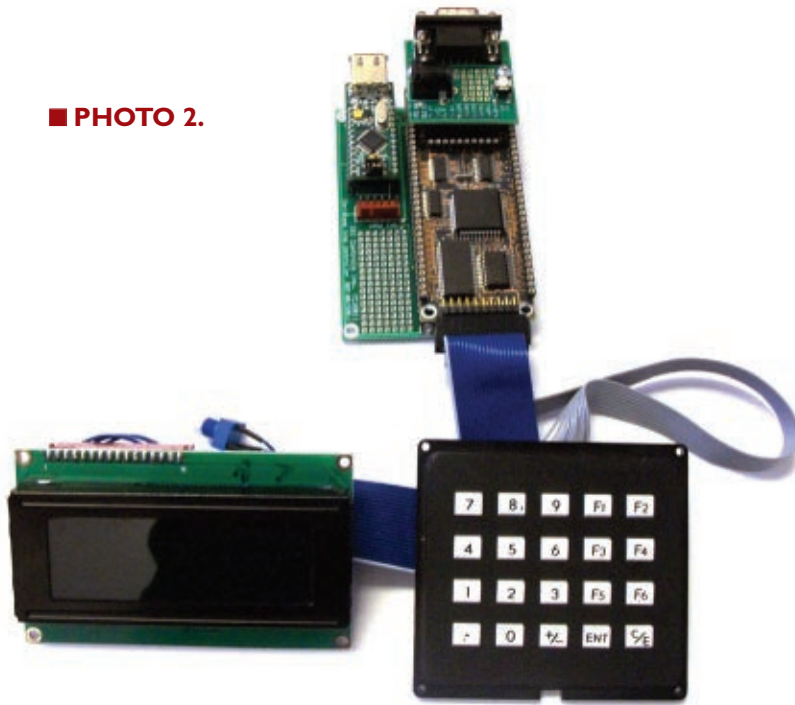

at the article link shown here.

With the second version of the hardware and software, the user can control morning and evening timers, and program the running sequence and speed of the routines. In addition to these programming features, the user can also test the different strings on the tree, as well as the colors. As seen in **Photo 2**, the Spectrum-ACE 2a, interface board, LCD, and keypad all plug together very easily, and then can go into whatever box the user wants. The last sub-assembly for the tree is a junction board for plugging in the 16 plugs from the 16 strings of LEDs. For the first prototype, this board was handwired, but a quick-turn PCB was much nicer for the finished project.

BUILDING THE TREE

Construction is pretty simple, but it does take some time. I built a simple jig from a piece of 12" x 12" perforated board for making up each string. Once I got the procedure down, a string could be built and tested in about 20 minutes. In **Photo 3**, the fixture is shown with a string being built. **Photo 4** is a completed string. Each string is made up of a total of 16 LEDs: four red, four green, four yellow, and four blue. I chose to use clear LEDs so when the tree was off, it would appear to just be a centerpiece on the table. I used five-pin Molex connectors on the end of each string.

Once all the strings are built and tested, the next step is to build the framework for the tree. The framework was made from 1/16 inch brass rod. The top of the tree is made from a small round piece of PCB material with 16 small holes for the rods to go into and then be soldered into place. (The same piece of perforated board used for the jig is used to build the frame of the tree.) Once the frame is built, heat shrink tubing is put over each piece of the brass rods to insulate the strings from the rods. Then, with the frame built, a final piece of brass rod is soldered completely around the base to help support the frame.

The next step is to mount each string on the frame. This is done with a combination of hot glue and small zip-ties. Once the tree is completely assembled, all that is needed is to load the software and you are good to go. **Photo 5** shows a completed tree. The final touch will be to add garland around it to give a finished look. The operating tree only consumes about three to four watts, depending on how much current you run through the LEDs. Once your tree is up and running, set back and enjoy the show!

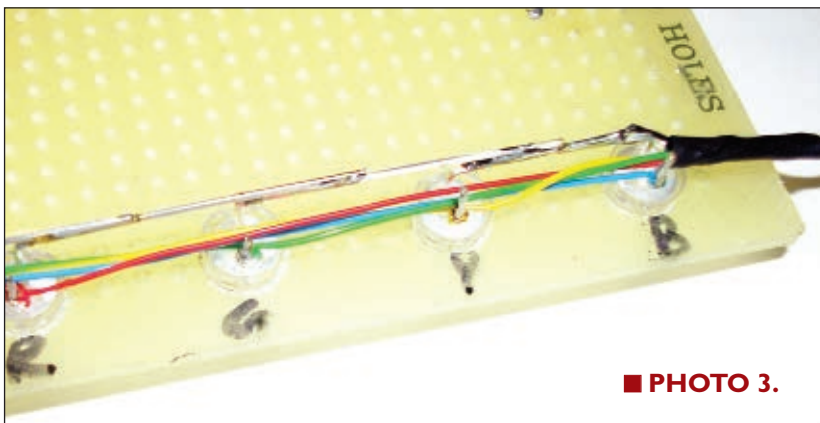

■ PHOTO 3.

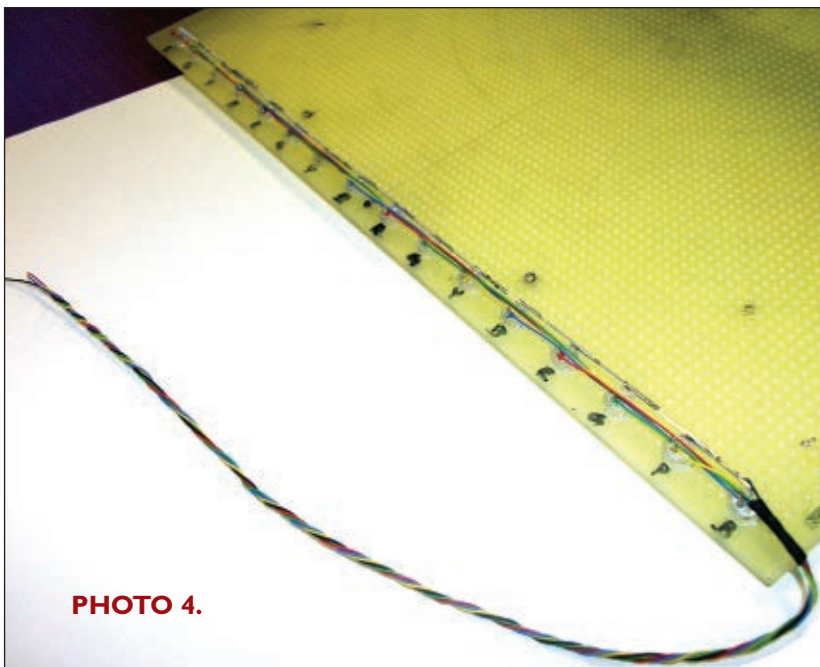

PHOTO 4.

WHAT'S NEXT?

Now that you have a great little centerpiece for the table, let's think bigger — you are going to enter the neighborhood lighting contest and you are driven to win! Well, this little tree can be a great start. All that is needed is to convert the drive signals from our little table-top tree to 110 volts AC (please use extreme caution in doing this!!). The easiest way is to use an SSR (solid-state relay). There are a number of companies that make SSRs. You can pick them up as surplus, make them yourself, or buy them new off the shelf. I decided to make them myself.

I knew that each string would need four channels and that there would be 16 strings. **Photo 6** is a prototype of the four-channel SSR, complete with heatsink and fuses. This SSR module is good for 400 watts per channel or 1,600 watts total. With this much power, you can control 25,600 watts total for 16 strings of lights. I wanted to see how big of a tree I could make but my power panel had other ideas, so I am limited to about 100 watts per channel and 400 watts per board, or 6,400 watts total.

The next step is to use the small junction board from the tree and replace the 150 ohm resistors with solder bridges across where the resistors go. Then, plug in one SSR module to each plug and you now have a beacon to guide an incoming sleigh and reindeer!

HEY, WHAT ABOUT THE SOFTWARE?

Okay, so now that we have covered the hardware, let's talk software.

The first bits (or bytes) of knowledge you need is what to get and where to get it. We can't print the source code for the entire project because of space limitations, so it's available on our website, along with all the workings of the bigger 2a project which includes a 4x20 character LCD and a 20-key keypad for controlling the tree while it's in operation. (The source code is also available at the article link.) That's way cool when running outdoors!

What can be done is a general overview of the source code modules and how to install them into your CPU board, some in-depth examination of what is in the functions that drive the project, and several prime examples of the routines that light the tree. The modules are not that large, and are fairly well documented. We'll also talk more about the programming environment that makes ALEC® a really great RAD (Rapid Application Development) tool.

To start, download the source code and unzip it to a working directory. There are three files that make up the Spectrum Lite version in ALEC®:

1. SmallTree.bas ~4 Kb
2. SmallTreeInit.inc ~4 Kb
3. LightRoutines.inc ~16 Kb

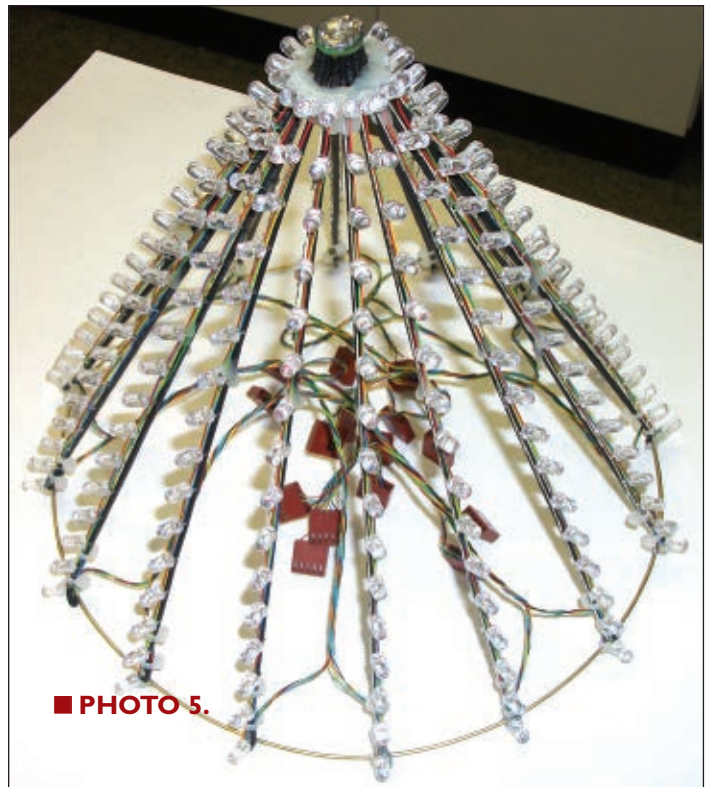

■ PHOTO 5.

The SmallTree application is only about 560 lines of onboard, microcompiler-ready code after compacting during the load-in using the Lexical Preprocessor in our Spectrum PortMaster terminal interface (a free application available on our website). The file, SmallTree.bas.lst (~21 kb), along with a reference file, SmallTree.bas.ref (~22 kb), are created during this load-in process, but are supplied for those using other terminal software.

To load the app, reset the CPU and initiate the conversation with ALEC® by pressing the space bar. Then, drag-n-drop (or send via the file dialog menu) the SmallTree.bas file (please note the common control settings provided in this file). The .lst, .ref, and .err files are re-created during the Lexical Preprocess and the app is

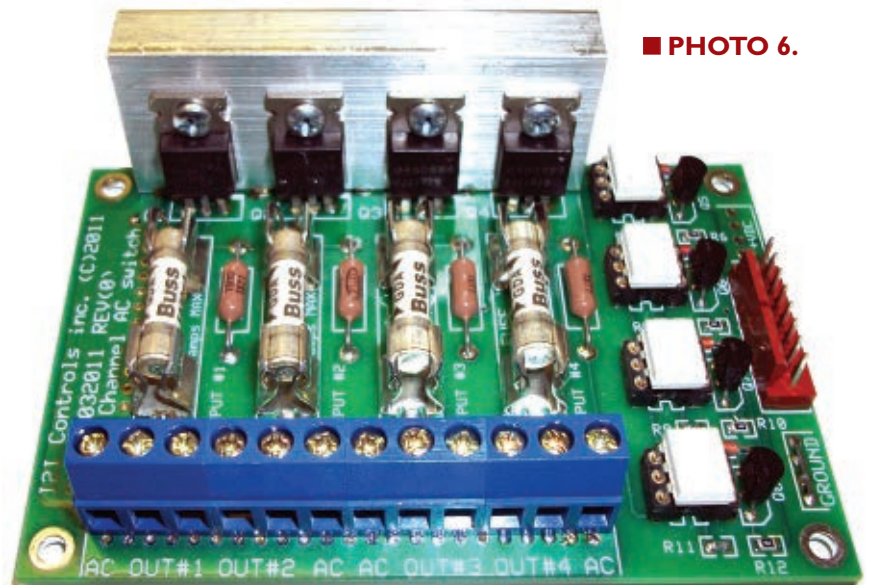

■ PHOTO 6.

```

{start}
gosub system_init

if rdm=1 jump random_start

{sequenced_start}
for h=0 to seq
  i=random_weight(h)
  dly=speed_data(i)*spd
  for j=0 to rpt_data(i)
    if i>10 then second_sequence
    on i-1 gosub pendulum, random_sweep, double_sweep.
    ...flashy, random_blast, pulsator, butterfly.
    ...solid_propeller, sparkle, random_flash
    jump over_second_sequence

{second_sequence}
  on i gosub double_fan, fill_empty, random_spoke.
  ...flashy_propeller, teeter_totter,
  ...negative_pulsator.
  ...pulsator_rotator, natural_reverse.
  ...flashing_sweep, pinwheel

{over_second_sequence}
  next j
  gosub reset_lights
next h
jump sequenced_start

... random operation code is here ...
.
#include "LightRoutines.inc"
#include "SmallTreeInit.inc"

```

FIGURE 2

```

{random_blast} RANDOM BLAST (#5)
  output "RANDOM BLAST (#5)"
  rtc(c)=int((1000*rnd)/4)+1
  p=int((1000*rnd)/4) : port1=p :
  rtc(a)=p
  for t=1 to dly : next t
return
; *** end random_blast (#5) ***

```

FIGURE 4

loaded. Press the Enter key for a new prompt. Type Prog at the prompt to compile and save to Flash. Type Exe to run SmallTree.

Loading the program using HyperTerminal or other serial communications software, reset the CPU and initiate the conversation with ALEC by pressing the space bar. Then, send the file SmallTree.bas.lst to the CPU. Press the Enter key for a new prompt. Type Prog at the prompt to compile and save to Flash. Type Exe to run SmallTree.

That was easy. Now, open the SmallTree.bas file in your favorite editor. The first half of the file is comment data, but read it anyway. Find the {start} label. This is where the fun begins. If you haven't already done so, please download the ALEC manual. It will be helpful along the way.

The labels for jump points and subroutines are enclosed in curly braces {}. So, the first call is to system_init, which is in the include file SmallTreeInit.inc as shown at the bottom of **Figure 2**. This sets up the hardware and loads some useful data. The next line checks for the start-up type, either running the light effects in random or sequential order (see the include file). The next label encountered is {sequenced_start} and 22 lines down is the jump back; contained between is the code for running the lighting routines in sequential order.

For-Next loops are common, and the variable named 'h' was chosen at random. Being a primary control loop variable, h is not re-used elsewhere. The loop is 0 to 19, as referenced by variable 'seq' in the include file.

Now that all the ground work is done, let's get on with it and set the effects in motion! The variable 'j' is another loop control but is within the primary loop. It is used to control how many repetitions each routine gets before moving to the next. This data is in the rpt_data array. This array is a copy of the original array data read in, repeat_in, and may be modified on the fly, referenced, and then restored from the original data.

The **ON - GOSUB** instruction in the j loop provides a simple way to call various subroutines, depending on the value of the expression (see the ALEC manual). The expression basically evaluates to an index into the list of routines following the GOSUB.

Reset the lights by calling the subroutine reset_lights, and do it all over again. That's it for sequential operation. Random operation simply calls the **RND** function (see the manual), changes it to an integer value, and substitutes the outcome to the variable 'i'.

Now, let's examine a couple of routines that light up the tree. Remember that the tree can be from a desktop to rooftop in size, but the controls are the same: Colors

12 | Controls LED Tree

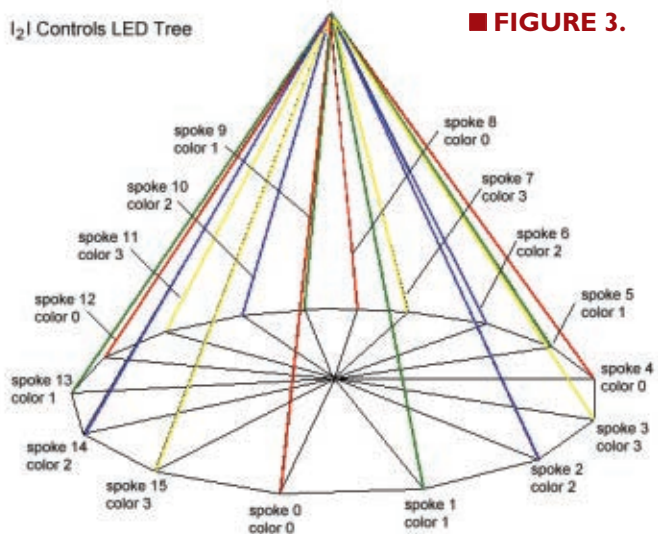

FIGURE 3.

```

{sparkle} SPARKLE (#9)
  output "SPARKLE (#9)"
  for m=3 to -2 step -1
    rtc(c)=color_data(abs(m))
    cb=1 : cc=1
    for p=1 to 11 step 2
      for e=1 to nat_rev(p)
        port1=nat_revb(cb)
        cb++
        if cb>15 then cb=0
        for t=1 to dly : next t
      next e
      for e=1 to nat_rev(p+1)
        rtc(a)=nat_revb(cc)
        cc++
        if cc>15 then cc=0
        for t=1 to dly : next t
      next e
    next p
  next m
return

```

FIGURE 5

0-3 are the real time clock I/O at 0x121h, or RTC(C). Spokes 0-7 are on PORT1 and Spokes 8-15 are at 0x120h, or RTC(A). Refer to **Figure 3**.

Open LightRoutines.inc in your editor. Let's start with the most simple routine: RANDOM BLAST, routine #5. This routine simply takes two random numbers and applies them to the color and spokes. Since a random number from ALEC can be anywhere from zero to one (ex: .709514), it must be upgraded to integers to be useful.

In **Figure 4**, the formula $\text{rtc}(c) = \text{int}((1000 * \text{rnd}) / 4) + 1$ is for the color. An example result is: $\text{rtc}(c) = \text{int}((1000 * .709514) / 4) + 1$, or $\text{int}((709.514 / 4) + 1$, or 178 decimal (0xB2h). Since the color range is zero to three and the register RTC(C) is a nibble, it evaluates to two and the rest of the data is superfluous. The spokes formula is similar – $\text{int}((1000 * \text{rnd}) / 4)$ – and is easily applied to both control ports using a trash variable 'p.' A time delay is added so that you actually see the effect, and the routine is repeated according to the data in the repeat routine data array, rpt_data(i) with i=4.

The next routine we'll examine is a fairly complicated piece of code that we call SPARKLE, routine #9. It steps through the individual colors while cycling the spoke controls from off to fully on and then off again. Outdoors, the kids really love it! As explained before, the color and spoke controls are eight-bit values either as I/O registers in the real time clock or port 1 of the CPU. So, the intent is to set up cycling color loops, and then turn the various spokes within on and off.

The routine starts with the color loop, using a FOR-NEXT loop from 3 to -2 with a step of -1, using the variable 'm' (see **Figure 5**). The color data is applied by using the absolute value function (ABS) within ALEC. This ensures an eight-bit value is written to the control. Two trash index variables ('cb' and 'cc') are initialized with the value of zero. The FOR-NEXT loop using the variable p reads the natural reverse array ('nat_rev') using a step increment of two.

Embedded within this loop are two more loops (using the variable 'e'): one that sets the control for the

lower eight spokes, and the other is for the upper eight spokes with an index value of +1. These reference data from the second and third natural reverse arrays 'b' and 'c' ('nat_revb' and 'nat_rev c'), and are applied to the controls at port 1 and rtc(a), respectively. Both rash index variables (cb and cc) are incremented after use to keep indexes current. Standard delays are applied as each control is updated.

Well, that's all we have room for here. Additional help for all the routines, plus programming tips and tricks are available on the I21 Controls website. When you visit, please sign the guestbook or register at the forum. **NV**

Component LEDs LED Bulbs LED Products

superbrightleds.com

Your One Stop LED Shop for all of your Halloween lighting decorations for costumes, props, and house.

All Products Available for Immediate Purchase Online

Super Bright LEDs Inc. St. Louis, Missouri - USA superbrightleds.com

SABERTOOTH 2X12 AND 2X12RC

The most popular small dual motor controllers.... Just got better!

Dimension Engineering
Welcome to the next generation of efficiency, performance, and value.

Specifications:

- 1A 5V Switching BEC
- 6-24V Input Voltage
- 2 x 12A Continuous Current
- 2 x 25A Peak Current

Features:

- Synchronous Regeneration
- Ultra Fast Switching Frequency (no whine!)
- Thermal, Overcurrent, and Lithium Protection
- Serial, R/C, and Analog Inputs

Sabertooth 2x12 \$79.99

Sabertooth 2x12RC \$64.99

(330) 634-1430
www.dimensionengineering.com
- Motor Controllers - DC to DC - Sensors - R/C Relays - R/C Lighting -



A FLASHER, GATE, AND BELL FOR YOUR MODEL RAILROAD

The intersection of a train track with a road provides a natural focal point of interest. Why not take advantage of it with a crossing signal that flashes and a gate that lowers when a train passes? This simple PIC microcontroller circuit even enhances the action with a realistic bell sound!

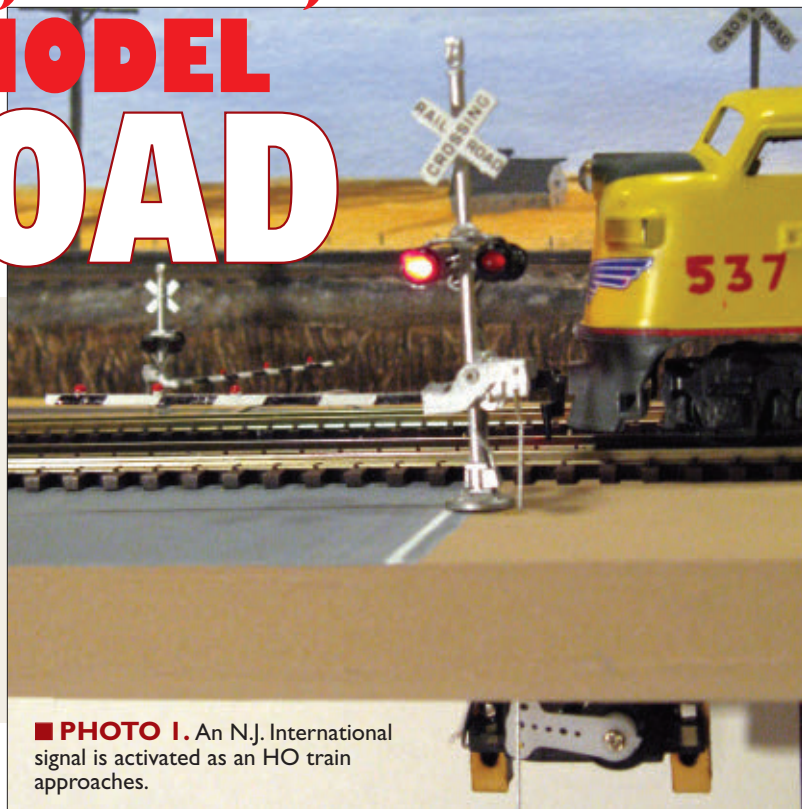

■ **PHOTO 1.** An N.J. International signal is activated as an HO train approaches.

To activate a signal, you need a way to detect approaching trains. Model railroaders have developed several methods over the years. For larger, heavier trains various configurations of mechanical switches can be used. However, most train layouts rely on more complicated methods, such as photodetectors or circuits that sense the current drawn by an engine in an electrically isolated section of track. The method described here uses magnetic reed switches. They're simple, inexpensive, and easy to install and conceal. Their one drawback might be that they require magnets mounted on the engine and caboose (or other tail-end car).

When an engine approaches a road crossing, its magnet closes the contacts of a reed switch hidden in the track. This sends a signal to a PIC that alternately flashes a pair of LEDs, pulses a servo motor that slowly lowers a gate, and sends digitized samples of a ringing bell to a speaker. The action continues until a second reed switch buried at the road crossing detects the passing of the caboose.

Circuit Board

The schematic and board layout in **Figures 1 and 2** reveal the simple circuit. It's basically a PIC with a bunch of I/O connectors and a power supply. A PIC16F684 was chosen because it's inexpensive, comes in an easy to handle package (DIP), and has support for pulse-width modulation (PWM) which is used for the bell sound. The circuit will drive two sets of flashers and two servos, so automobile traffic is protected in both directions. Of course, you can use any combination of the outputs. You might, for instance,

want to start with just one flashing signal and add the gates and speaker later. Please note that there is only enough power to operate LEDs and not incandescent bulbs.

A 7805 regulator provides the required five volts. It accepts a wide variety of input voltages — both AC and DC — but is typically driven from the 18 VAC accessory power provided by most train transformers. The relatively large 470 μ F capacitor on the output provides momentary surge power for the servo motors. The 220 ohm resistors on the PIC's output lines not only limit the current for the LEDs, but also protect the PIC from short circuits if connectors are plugged in wrong or wires on the layout are shorted. The 22K pull-up resistors are required for inputs on port C, but not port A since it has built-in pull-ups. The 82 ohm resistor limits the maximum current drawn by the 100 ohm speaker. The 5K pot provides a volume control. The 1.0 μ F cap filters out most of the aliasing noise in the bell waveform which is sampled at 8 kHz.

Assembly

Begin by gathering all the parts and necessary tools. Solder in the shorter parts first. Install the 14-pin IC socket for U2, being sure to orient it correctly. Install the two 220 ohm resistor networks RN1 and RN2. Don't confuse their locations with the six-pin locations used for sockets S1 and S2. Tape is useful to hold the connectors in place while soldering. Mount the 1.0 μ F capacitor, C4, on-end.

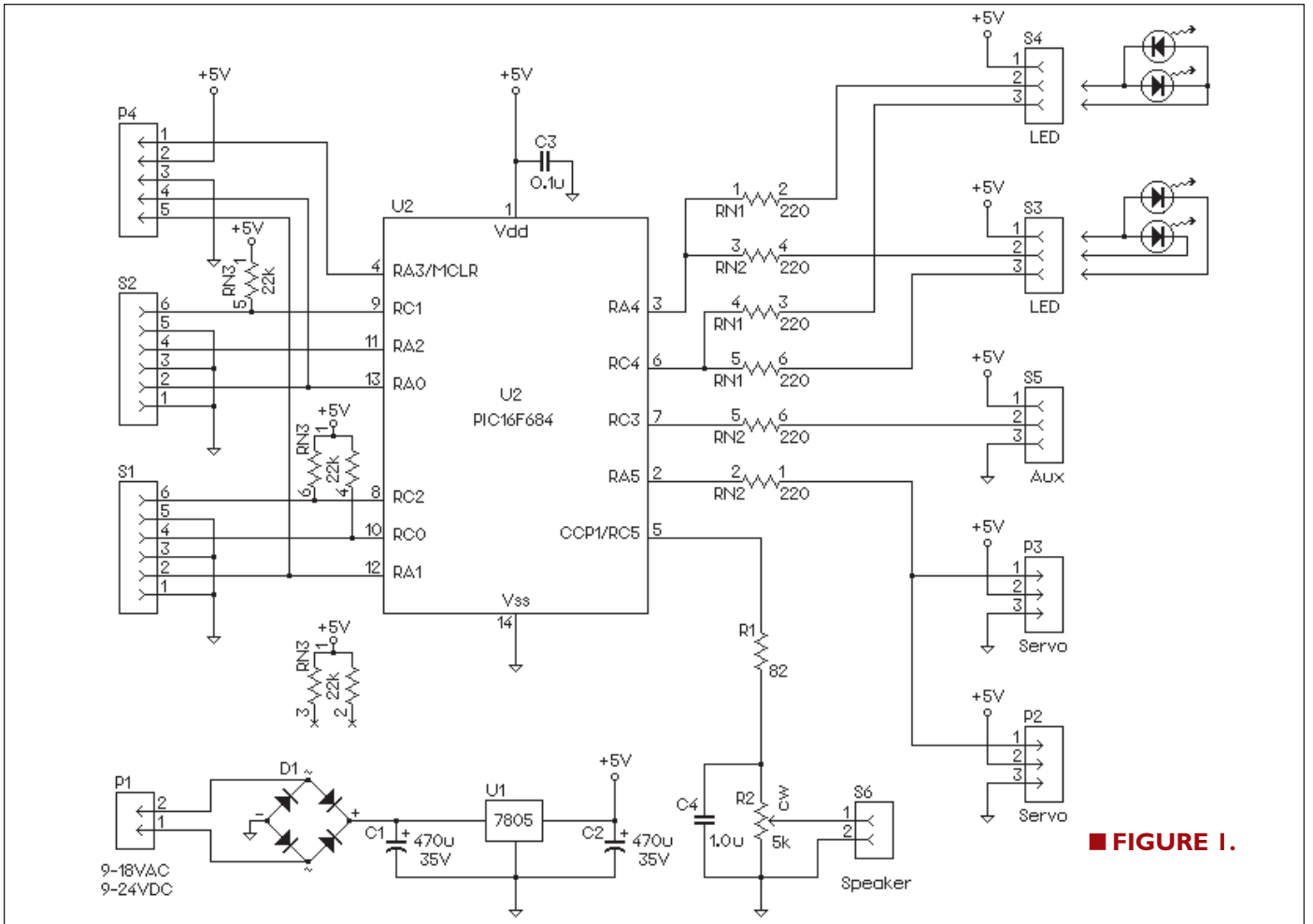

■ FIGURE 1.

Finish by installing the taller parts. Note the polarity on the electrolytic capacitors C1 and C2. Solder in the 7805 regulator with its metal tab facing C1 and C2. Apply about a pinhead's worth of heatsink compound to the heatsink, then – with its silver tab up – slide it onto the 7805 until it's even with the bottom of the regulator's case. There should be a slight air gap between the heatsink and C1 and C2. Make a power cable with a length of two-conductor wire soldered to a two-hole connector. Plug it onto the two pins extending up from the circuit board, and connect the other end to a nine to 18 volt power source. If the five volt output of the 7805 checks out okay, remove power and plug in the PIC, being sure to orient it properly. Refer to **Photo 2**.

Reed Switches

At least two reed switches must be mounted on your layout: one to detect approaching engines and one to detect when the last car (caboose) has cleared the road. If trains run in both directions, then a third switch must be mounted. The circuit supports up to six reed switches which will detect trains on double tracks traveling in both directions. Cables for the reed switches are made as follows. Bend the leads on a reed switch using needle-nose pliers so that they both point in the same direction, parallel to the

glass tube (see **Photo 3**). Be careful not to apply force against the tube because it can break easily (believe me, I know). Trim the lead with the 180 degree bend so that its solder joint will end up alongside the glass tube where it can't short against the other lead. Trim this other, straight

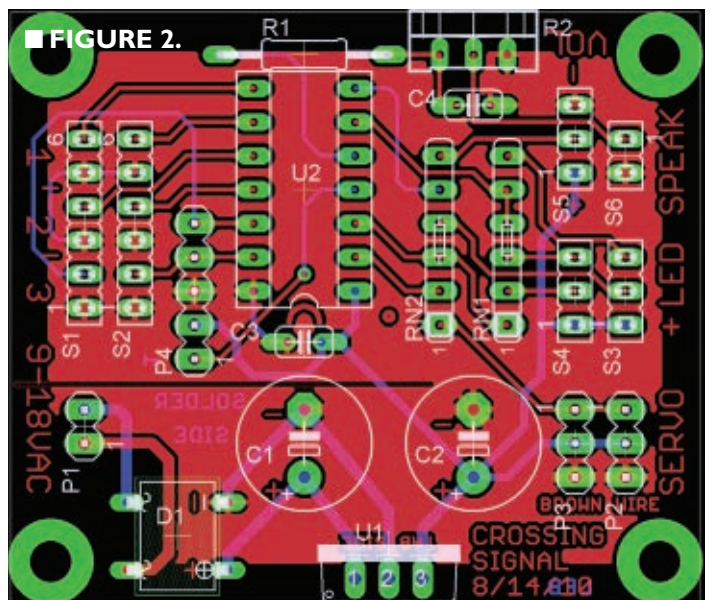

■ FIGURE 2.

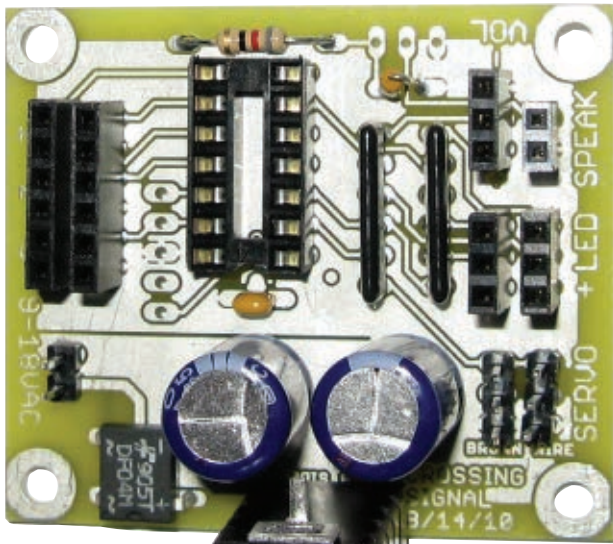

■ PHOTO 2.

lead about 1/4" from the tube. Trim the leads on a one foot length of 24 gauge two-conductor wire to match the leads on the reed switch, and solder them onto the switch. This is easier if you tin all four leads first. Make cables for the other reed switches, but use lengths of wire needed for the approach distance (plus a little extra for "engineering margin"). Encapsulate each reed switch in a 1-1/2" length of 3/16" heat shrink tubing. The heat shrink should not extend beyond the end of the glass tube (again see **Photo 3**). Attach a two-pin connector to the leads at the opposite end of the reed switch cable. An easy way to do this is to strip 1/8" insulation off both leads (simultaneously), then align the stripped ends with a two-pin connector as shown in **Photo 4**. The short leads of the connector are the soldered end. Slightly spread the wire leads if necessary using a screwdriver blade to get a precise alignment with the connector. Solder and insulate the joint with a dab of hot melt glue.

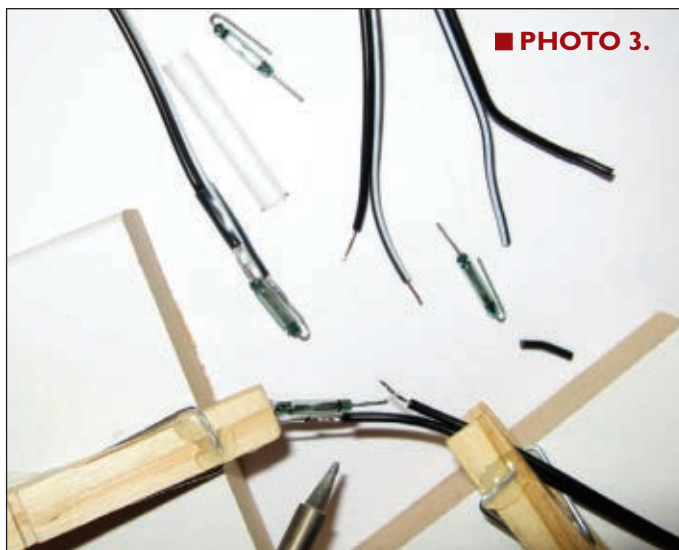

■ PHOTO 3.

Signals

Several different brands of signals can be used. **Photo 1** shows a pair of realistic ones (in both HO and N scales) made by N.J. International. These come with LEDs and a gate arm. Much less expensive signals are made by Bachmann (also available in HO and N scales), but you'll need to install the LEDs yourself and purchase the gates separately. **Photo 5** shows a pair of Life-Like signals which are more realistic than Bachmann's, but they also require the LEDs to be installed. **Photos 6** and **7** show how to do this. The original lenses are removed by placing them over an 1/8" hole (such as on the circuit board) and punching them out with a nail set. The alignment jig prevents melting the delicate plastic signal while soldering. Connecting the LEDs back to back (rather than common anode) requires only two leads, and fine magnet wire is easy to conceal. A small connector attached to the opposite end facilitates mounting (and especially un-mounting) on your layout.

Initial Checkout

Plug the reed switch cables into S1 – the six-hole socket at the edge of the board. The cable from the center of the road goes into the center two holes marked "2." The order of the other reed cables doesn't matter, but they must be on S1. Plug a signal into the three-hole LED socket. Note that two kinds of signals are supported: the Life-Like ones use a two-pin connector, while most commercial signals such as N.J. International's use a three-pin connector. The black wire (common anode) on the three-pin N.J. International connector goes in the hole marked "+." The two-pin Life-Like connector goes in the other two holes. If the signals are plugged in wrong, it won't damage anything. At this point, you might also want to connect the speaker and servos, but we're mainly interested in testing the signal LEDs. Power on the circuit board. Both LEDs on the signal should flash momentarily. Use a hand magnet to activate one of the reed switches. The signal should alternately flash right and left. It might stop after 30 seconds depending on which reed you activate, but this is normal and explained

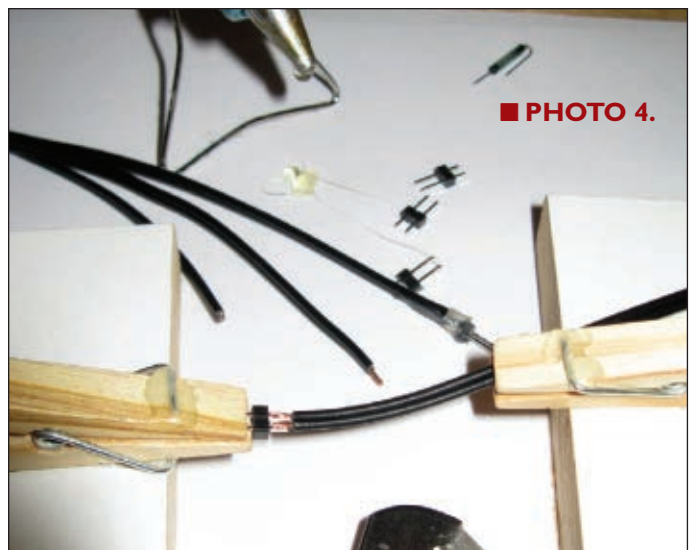

■ PHOTO 4.

below. As with any electronic device, it's a good idea to use a surge suppressor on the 120 VAC power line.

Mounting

Drill $3/16$ " holes in the center of the track to mount the reed switches. Insert them from the underside of the layout and glue (Goop) them in place. The switches should protrude up about $1/32$ " below the tops of the rails as shown in **Photo 8**. Attach a $1/8$ " x $1/8$ " super magnet with its poles aligned up and down, under an engine in its center near the front. It might not be necessary to glue the magnet if it simply attaches to some metal. Similarly, attach a magnet under a caboose (or other rear-end car) at its center near the rear. The magnets should clear the tops of the rails by about $1/32$ ". If it turns out the magnets aren't strong enough to activate the reed switches, additional magnets can be stacked onto the originals. The magnetic fields will add. Mount your signals on the layout following the manufacturer's recommendations. The way a speaker is mounted can make a big difference in its volume and sound quality. Ideally, it should be mounted against a $1-1/2$ " hole in the surface of the layout. **Photo 8** shows the top of the hole covered with nylon screen which can be concealed by scenery materials. An array of $1/4$ " holes drilled in the layout works almost as well. Another possibility is to mount the speaker on a small board under the layout as shown in **Photo 9**.

Servo Mounting

Installing the servo motor that operates the crossing gate requires some skill and dexterity, especially for N scale and smaller. Begin by mounting your gate on the layout. If it's designed to be operated — like the N.J. International gate — it will have a linkage wire already attached. Otherwise, you'll have to devise this linkage yourself. (A paper clip works well for a Bachmann gate.) Drill an oversized hole (about $1/8$ ") in the layout to allow for some lateral movement of the linkage.

Be aware that — especially for N scale — the servo and reed switch at the road are mounted near each other and could interfere with each other. Also, the linkage on an N-scale N.J. International signal must be extended if the layout board is $3/4$ " thick or more.

The servo must be rotated to the down position of the gate. Plug it into the circuit board (noting the orientation of the brown wire on its cable) and power up the board. The servo will immediately move to its up position. Move it to its down position by activating one of the reed switches. When the servo is in the down position, remove power. Attach the small nylon arm to the servo at the approximate angle shown in **Photo 10**. This will make its average

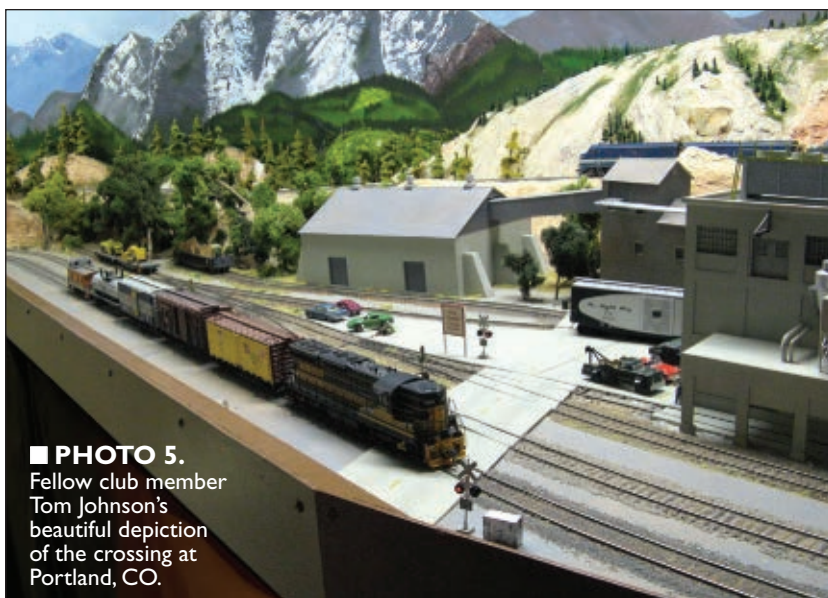

■ **PHOTO 5.**
Fellow club member Tom Johnson's beautiful depiction of the crossing at Portland, CO.

position horizontal as it swings up and down. Determine how the servo will be oriented in its bracket and on the layout. The servo arm rotates clockwise to move the gate up.

Loosely attach the servo to the mounting bracket with 2×12 mm machine screws. Mark the position where the bracket and servo will be mounted on the layout. For the HO N.J. International gate, the linkage moves about $1/8$ " to move the gate through its range. (The precise range is adjusted later.) This roughly corresponds to the movement of the innermost hole in the servo arm. Therefore, this hole should be centered under the linkage hole in the layout.

Be sure that any wires from the signal are routed such that they don't interfere with the motion of the servo. Make two holes in the layout to mount the bracket by its (adjustable) slots, then attach it with wood screws.

Bend about $1/4$ " of the linkage wire 90 degrees so it engages in the hole in the servo arm. Insert it in the hole, then bend the last $1/8$ " of the linkage another 90 degrees to keep it from slipping back out of the hole.

Slide the servo up or down in the bracket slots to move the gate to its down position, then tighten the screws that

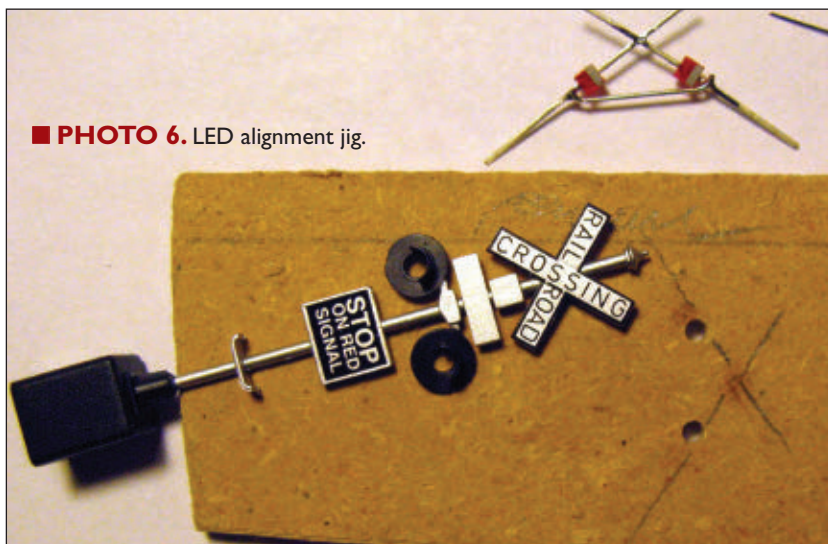

■ **PHOTO 6.** LED alignment jig.

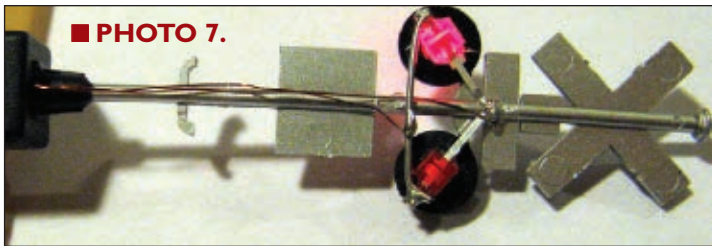

■ PHOTO 7.

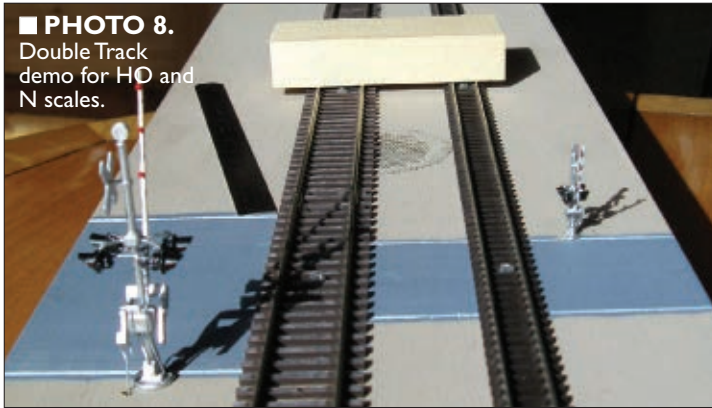

■ PHOTO 8.
Double Track
demo for HO and
N scales.

hold the servo onto the bracket. You may want to put a dab of Loctite (nail polish or glue) on the nuts.

Cycle power on, then off. This will move the gate to its default up position. This position is adjusted as follows. With the power off, put magnets on reed switches 1 and 2 so they close. (These reeds are on positions 1 and 2 on connector S1.) Turn the power on. One of the signal LEDs will remain on indicating that the microcontroller is in its gate-adjustment mode.

Gently tap the magnet on reed switch 1 to move the

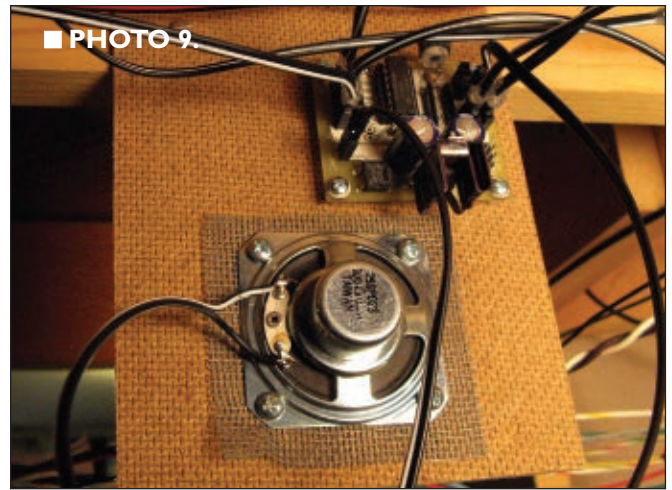

■ PHOTO 9.

gate upward a step at a time. Tapping on reed 2 moves the gate downward. Using these controls, adjust the desired up position. When power is cycled, the gate will operate from this position, because it's recorded in the PIC's internal EEPROM. If the servo makes a buzzing noise, it's probably straining against a physical limit. It should be readjusted to prevent it from drawing excessive power.

Software

Since I'm a programmer by trade, I like to think that most of the magic of this project is in the software. It's what enables us to get by with such a simple and inexpensive circuit. Because the bell waveform is sampled by an interrupt routine 8,000 times per second, and because the

servos are sensitive to even a few microseconds of variation in pulse widths, I chose assembly language rather than C code to maintain control over each CPU cycle. Basically, the code executes a big loop 20 times per second that samples the reed switch inputs and, if a train is detected, it alternately flashes the LEDs and sends gradually changing pulse widths to the servos. While this is going on, a timer triggers an interrupt handler that sends sound samples to the PIC's PWM register. The servos move to a position dependent on the width of a pulse that they receive. When the gate moves down, the pulse widths step down 20 times a second, from about 1,500 microseconds to 750 microseconds. The bell waveform data takes up almost all of the PIC's 2K words of program memory. Sampled at 8,000 times per second, this provides a

QTY	ITEM	DESCRIPTION	SUPPLIER PART #
Parts for crossing signal circuit board (in recommended order of assembly):			
1		Printed circuit board	Advanced Circuits
1	R1	Resistor, 82 ohm	Mouser 291-82-RC
1	D1	Bridge rectifier, DF04M, 1A, DIP	Jameco 102971
1		Socket, IC, 14-pin DIP	Jameco 112214
2	RN1,2	Resistor networks, 220 ohm, six-pin SIP	Mouser 267-220-RC
2	S1,S2	Sockets, 0.100" six-hole	Digi-Key S7004-ND
5	P2,P3	Headers, 0.100" three-pin	Digi-Key WM6003-ND
3	S3-S5	Sockets, 0.100" three-hole	Digi-Key S7001-ND
7	P1	Headers, 0.100" two-pin	Digi-Key WM6002-ND
2	S6	Sockets, 0.100" two-hole	Digi-Key S7000-ND
1	C4	Capacitor, 1.0 µF axial ceramic, "105"	Jameco 546345
2	C1,C2	Capacitors, 470 µF 35V radial	Mouser 667-ECA-1VM471B
1	U1	LM7805AC, 5V regulator, 1.5A	Jameco 924570
1		Heatsink TO-220	Jameco 2077327
1	C3	Capacitor, 0.1 µF radial ceramic, "104"	Jameco 544868
1	RN3	Resistor network, 22K ohm, four-pin SIP	Mouser 264-22K-RC
1	U2	PIC16F684, microcontroller, programmed, DIP-14	Mouser 579-PIC16F684-I/P
30		Feet wire, 24 gauge, two-conductor, stranded	Jameco 100299
6		Magnetic reed switches	Digi-Key HE503-ND
6		3/16" heat shrink tubes, clear	Jameco 1555219
4		LEDs, 1.9 mm red diffused, Avago	
4		Spacers, mounting, 5/32" #4	
4		Wood screws, #4 1/2" Phillips	
6		Rare earth magnets, rod 1/8" x 1/8"	
Parts for gate servo:			
1		Servo motor, Dynam 9g	
1		Mounting bracket	HobbyPartz.com
2		Machine screws & nuts, 2x12mm	
2		Wood screws, #4 1/2" Phillips	
2		Linkage wires (paper clips)	
Parts for bell sound:			
1		Speaker, 1.75" square, 100 ohm, 0.2W	Mouser 25SP023
1	R2	5K pot	Mouser 652-3352W-1-502LF
14		Inches wire, 24 gauge, two-conductor, stranded	
1		Header, 0.100" two-pin	Digi-Key WM6002-ND
4		Wood screws, #4 1/2" Phillips	
1		2.5" x 2.5" screen mesh, nylon	

PARTS LIST

fleeting quarter second of sound, but it's sufficient for one strike of the bell. It's possible that the system can get out of sync, for instance, if a caboose is mistaken for an approaching engine. Thus, the software utilizes a 30 second time-out to resynchronize things. The exact way all of this works is explained in the meticulously commented source code that can be downloaded from the article link at www.nutsvolts.com.

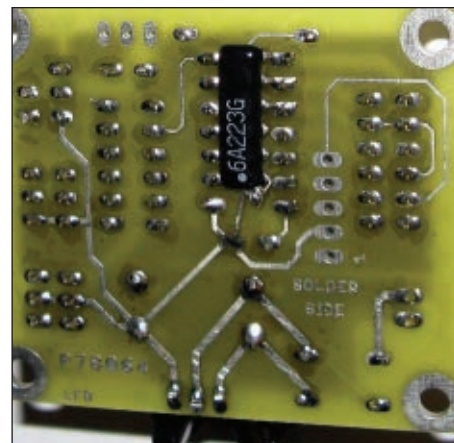

■ **PHOTO 11.** A lesson learned the hard way was that pull-ups had to be added to the port C inputs. Two leads on RN3 are removed to prevent shorts, and the common lead is jumpered to +5V.

Conclusion

This crossing system has been successfully installed on both HO and N scale layouts by several members of my railroad club; so the bugs have been worked out. A couple lessons were learned the hard way. Don't connect the PIC's MCLR pin (which can be reconfigured as an input) with a long cable because it's sensitive to electrostatic discharges (ESD). Also, don't assume while laying out traces on the circuit board that you can arbitrarily reassign the PIC's I/O lines to untangle things. Unlike the PIC24, the PIC16 only provides internal pull-ups on port A, not on port C (refer to **Photo 11**).

The auxiliary (AUX) signal was added at the request of a club member who wanted to have a watchman raise a lantern. If you use an inductive load on this signal, there should be a protection diode (an ordinary diode connected backwards across the coil) to suppress any back EMF. The AUX connector also provides a regulated five volts. If you really care about the "little people" on your model railroad, you'll protect them with this road crossing signal! **NV**

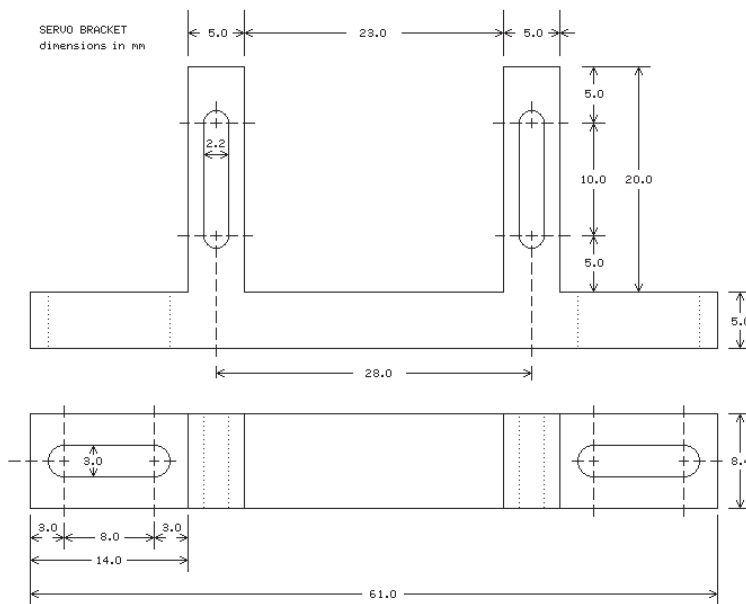

■ **FIGURE 3.** Servo bracket.



PBP3
PICBASIC PRO™ Compiler

Experimenter - \$49.95
Silver Edition - \$119.95
Gold Edition - \$269.95

The industry-standard BASIC compiler for Microchip PIC® microcontrollers.

Multi-Seat Licensing
for Educational Institutions

Upgrade from
PICBASIC™ Compiler (PBC)

Download a FREE trial version now.

www.PBP3.com

microEngineering Labs, Inc.

www.melabs.com

888-316-1753

PICBASIC and PICBASIC PRO are trademarks of Microchip Technology Inc. in the USA and other countries. PIC is a registered trademark of Microchip Technology Inc. in the USA and other countries.

Model 324

WORLD'S MOST VERSATILE CIRCUIT BOARD HOLDERS

Our line of Circuit Board Holders add versatility & precision to your DIY electronics project. Solder, assemble & organize with ease.

MONTHLY CONTEST
Visit us on Facebook® to post a photo of your creative PanaVise project for a chance to win a PanaVise prize package.

PANAVISE®
Innovative Holding Solutions

7540 Colbert Drive • Reno • Nevada 89511
1 (800) 759-7535 | www.PanaVise.com

Model 201

VISIT US ON  



AP CIRCUITS

PCB Fabrication Since 1984

As low as...
\$9.95 each!

Two Boards
Two Layers
Two Masks
One Legend

Unmasked boards ship next day!

www.apcircuits.com



NORITAKE ITRON TRICK OR TREAT GIVEAWAY FREE VFD MODULE KIT!

VISIT THE FOLLOWING SITE FOR OFFICAL RULES AND RESTRICTIONS
<http://itron.tv/NV10FREE>



<http://itron.tv/NV10FREE>

Noritake itron®
The brighter side of electronics

Noritake Co., Inc. Arlington Heights, IL 60005 (847) 439 - 9020

Number One Kits for Electronic Enthusiasts

Wideband Fuel Mixture Controller Kit

KC-5486 \$57.75 plus postage & packing

Partner to the Fuel/Air Mixture Display Kit KC-5485 (see below) and intended to be used with a Bosch wideband LSU4.2 oxygen sensor to accurately measure air/fuel ratios over a wide range from rich to lean. It can be used for precise engine tuning and can be a permanent installation in the car or a temporary connection to the exhaust tailpipe. Requires Bosch Wideband oxygen sensor LSU4.2.



- 12VDC
- PCB and electronic components
- Programmed PIC
- Case with screen printed lid

Fuel/Air Mixture Display Kit

KC-5485 \$43.25 plus postage & packing

Display your car's air-fuel ratio as you drive. Designed to monitor a wideband oxygen sensor and its associated wideband controller (see KC-5486 above). Alternatively, it can be used for monitoring other types of engine sensors.



- Double-sided plated through PCB
- Programmed PIC
- Electronic components
- Case with machined and screen printed lid
- PCB: 80 x 50mm

Universal Power Supply Regulator

KC-5501 \$11.00 plus postage & packing

One small board and a handful of parts will allow you to create either a regulated $\pm 15V$ rail or $+15VDC$ single voltage from a single winding or centre tap transformer (not included).



- Includes all PCB and components for board, transformer not included
- PCB: 72(L) x 30(W)mm

Speedo Corrector MkII Kit for Cars

KC-5435 \$39.75 plus postage & packing

When you modify your gearbox, diff ratio or change to a large circumference tyre, it may result in an inaccurate speedometer. This kit alters the speedometer signal up or down from 0% to 99% of the original signal. With this improved model, the input setup selection can be automatically selected and it also features an LED indicator to show when the input signal is being received. Kit supplied with PCB with overlay and all electronic components.



- PCB: 105 x 61mm

IR Remote Extender MKII Kit

KC-5432 \$19.50 plus postage & packing

Operate your DVD player or digital decoder using its remote control from another room. It picks up the signal from the remote control and sends it via a 2-wire cable to an infrared LED located close to the device. This improved model features fast data transfer, capable of transmitting PayTV digital remote control signals using the Pace 400 series decoder. Kit supplied with case, screen printed front panel, PCB with overlay & all electronic components.



- PCB: 79 x 47mm
- Requires 9VDC wall adaptor

"Minivox" Voice Operated Relay

KC-5172 \$11.50 plus postage & packing

Voice operated relays are used for 'hands free' radio communications and some PA applications etc. Instead of pushing a button, this device is activated by the sound of a voice. This tiny kit fits in the tightest spaces and has almost no turn-on delay. 12VDC @ 35mA required. Kit is supplied with PCB electret mic, and all specified components.



- PCB Dimensions: 47 x 44mm

12/24VDC 20A Motor Speed Controller Kit

KC-5502 \$29.00 plus postage & packing

Control the speed of 12 or 24VDC motors from zero to full power, up to 20A. Features optional soft start, adjustable pulse frequency to reduce motor noise, and low battery protection. The speed is set using the onboard trimpot, or by using an external potentiometer (available separately, use RP-3510 \$2.00).



NEW 2011

- Kit supplied with PCB and all onboard electronic components
- Suitable enclosure UB3 case, HB-6013 \$2.50

Clifford The Cricket

KC-5178 \$12.50 plus postage & packing

Clifford hides in the dark and chirps annoyingly until a light is turned on - just like a real cricket. Clifford is created on a small PCB, measuring just 40 x 35mm and has cute little LED insect eyes that flash as it sings. Just like a real cricket, it waits a few seconds after darkness until it begins chirping, and stops instantly when a light comes back on.



- PCB, piezo buzzer, LDR plus all electronic components supplied

Hundreds Sold

Universal Voltage Switch

KC-5377 \$23.75 plus postage & packing

This is a universal module which can be adapted to suit a range of different applications. It will trip a relay when a preset voltage is reached. It can be configured to trip with a rising or falling voltage, so it is suitable for a wide variety of voltage outputting devices eg., throttle position sensor, air flow sensor, EGO sensor. You could even use it to trigger an extra fuel pump under high boost, anti-lag wastegate shutoff, and much more. Kit supplied with PCB, and all electronic components.



- PCB: 105 x 60mm

Ultrasonic Antifouling for Boats

KC-5498 \$179.50 plus postage & packing

Marine growth electronic antifouling systems can cost thousands. This project uses the same ultrasonic waveforms and virtually identical ultrasonic transducers mounted in sturdy polyurethane housings. By building yourself (which includes some potting) you save a fortune! Standard unit consists of control electronic kit and case, ultrasonic transducer, potting and gluing components and housings. The single transducer design of this kit is suitable for boats up to 32ft boats longer than about 45ft will need two transducers and drivers. Basically all parts supplied in the project kit including wiring. (Price includes epoxies).



- 12VDC
- Suitable for power or sail
- Could be powered by a solar panel/wind generator
- PCB: 78 x 104mm

MORE INFO AVAILABLE ONLINE

KIT OF THE MONTH

Ultrasonic Water Tank Level Indicator Kit
KC-5503 \$54.00 plus postage & packing

Designed for plastic and concrete tanks, or steel tanks with modification, this water level indicator kit uses an ultrasonic assembly that mounts inside the tank and a microprocessor controlled meter to display the water level. Selectable between 10 LED Bargraph or 19 level Dot mode. Easy to calibrate, can be pushbutton or permanent display, powered by a 9V battery or power adaptor (available separately) and can be used with fluids other than water. Kit includes PCB, waterproof case and all electronic components. Silicon sealant not included.



MORE INFO AVAILABLE ONLINE



Don't just sit there BUILD SOMETHING!

- Suits tanks up to 2.4m high
- PCB: 104 x 78.5mm

Post & Packing Charges

Order Value	Cost
\$25 - \$49.99	\$7.50
\$50 - \$99.99	\$20
\$100 - \$199.99	\$40
\$200 - \$499.99	\$60
\$500+	\$75

Max weight 12lb (5kg).
Heavier parcels POA.
Minimum order \$25.

HOW TO ORDER

WEB: www.jaycar.com
PHONE: 1-800-784-0263*
FAX: +61 2 8832 3118*
EMAIL: techstore@jaycar.com
POST: P.O. Box 107, Rydalmere NSW 2116 Australia
• ALL PRICING IN US DOLLARS • MINIMUM ORDER ONLY \$25

*Australian Eastern Standard Time
(Monday - Friday 09.00 to 17.30 GMT + 10 hours)
Note: 10-14 days for air parcel delivery

Note: Products are dispatched from Australia, so local customs duty & taxes may apply.
Prices valid until 31/10/2011

Order online: www.jaycar.com

Jaycar
Electronics

LEGACY COMMUNICATION WITH THE 32-BIT MICRO EXPERIMENTER

BY THOMAS KIBALO

Legacy communication is still very prominent and in high use with microcontrollers. This article will explore the use of a legacy communication that exists between a 32-bit Experimenter (as a terminal) and a PC. Legacy communication uses the traditional RS-232 serial, and the communications payload is ASCII characters. Of interest is how the Experimenter PIC32 microcontroller achieves this, and what specific hardware and software is required.

A block diagram of the experiment is shown in **Figure 1**. **Figure 2** shows the prototype with an expanded view of the Experimenter display. One end of the RS-232 cable will connect to a PC (not shown). (A future article will discuss how to convert this RS-232 communication to the Experimenter on-board USB using a CDC class of device driver.)

To build a legacy Microcontroller Terminal, we'll use the 32-bit Experimenter (or Experimenter for short), the universal graphics board configured as a 12x8 character display, the Mini-kit (available from the *Nuts & Volts* Webstore) for keyboard and rotary inputs, and an RS-232 serial interface (consisting of both RS-232 cable and interface electronics). We will cover these components and associated software in more detail, in the discussions to follow. Think of all these components as building blocks that are used together for this experiment, but that can also be used individually or in different combinations for use in your own future Experimenter applications.

For example, an application can use the PS/2 keyboard for general operator entry, or use the rotary knob for a precision rotation and direction setting, or replicate the serial port across all five of the available Experimenter UARTs (Universal Asynchronous Receiver Transmitters) for enhanced legacy communications. In a sense, this experiment is an exercise in embedded system integration where diverse components are put together to create an assembled whole. Again, as in other Experimenter applications, some familiarity with C language

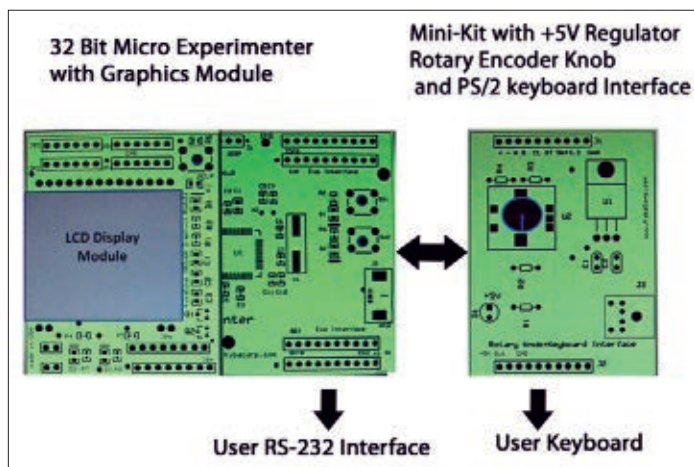

FIGURE 1. Experimenter terminal setup.

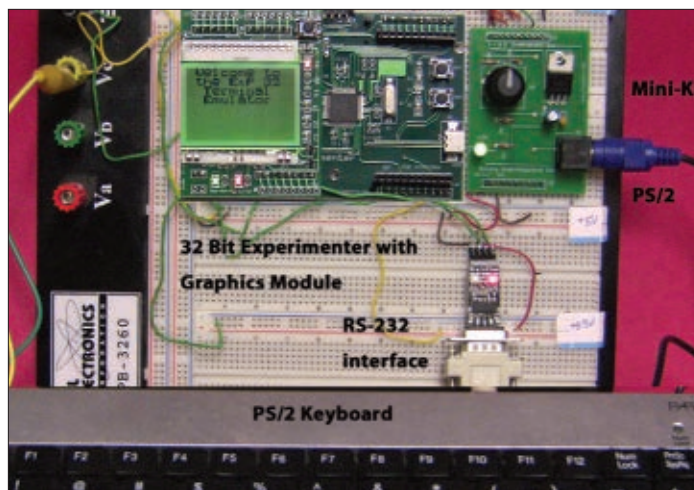

FIGURE 2. Prototype shown without PC.

is required. However, to make code reuse easier, the majority of demo software is written as library functions.

Working with the PC itself is fairly straightforward, as it already supports legacy serial communication with an application like HyperTerminal.

The 12x8 LCD Character Display Operation

The 12x8 character display uses the universal graphics display module that was introduced in the June '11 issue of *Nuts & Volts*. This graphics display has a pixel matrix of

102 horizontal by 64 vertical, for a total graphics complement of 6,528 pixels. By using a fixed font of 8x8 pixels per character, this display (using new software) emulates a 12x8 LCD character display (see **Figure 3**).

Here's the LCD display software library. The functions and their use are straightforward. This library is used to write strings onto the graphics display.

- **void LCDInit(void)** – Called once to initialize the display and Experimenter I/O.
- **void LCDUpdate(void)** – Updates the entire display with contents of LCDText[[]].
- **void LCDErase(void)** – Clears the entire display and content of LCDText[[]].
- **void LCDWriteLine(WORD number, char *line)** – Updates a designated row (indicated by number 1 to 8) on the display.

The good news is that the above four functions mimic Microchip's LCD interface for their family of evaluation boards using a character display, and are used extensively throughout their applications library. So, if you want to host their library applications on the Experimenter, just replace their library function LCDBlocking.H and LCDBlocking.C with our Graphics.h and Graphics.c. Everything should compile and work without issue. A demo program is provided that illustrates the use of this LCD library. Open LCDtest.MCP in the LCD folder, (included with the article downloads) build, and then program an Experimenter equipped with a universal graphics module. You should see what's in **Figure 4**. There are also additional library functions used to write characters onto the display:

- **AT (X, Y)** – Macro to position the cursor on the display before writing a character. X is 0 to 11; Y is 0 to 7.
- **putcV (char)** – Writes a character to the display memory at the current cursor position.
- **dumpVmap ()** – Updates the display with new characters.

Finally, there are functions in the display library that provide independent control of the two LEDs (green/red) on the display module, as well as the LCD display backlights (which are also green and red). The green backlight has a controlled brightness feature. The red backlight is simply on or off. Feel free to activate both and experiment with the color mix to "jazz up" your display operations.

- **void redBLON(void)** – Turn red LCD backlight on.
- **void redBLOFF(void)** – Turn red LCD backlight off.
- **void greenBLOFF(void)** – Turn green LCD backlight off.
- **void greenBLON(int setting)** – Turn green LCD backlight on with dim setting (0 to 64K), where 0 is dimmest and 64K is brightest.
- **void greenLEDON(void)** – Turn green LED on.
- **void greenLEDOFF(void)** – Turn green LED off.
- **void redLEDON(void)** – Turn red LED on.
- **void redLEDOFF(void)** – Turn red LED off.

The graphic module board itself contains SMT

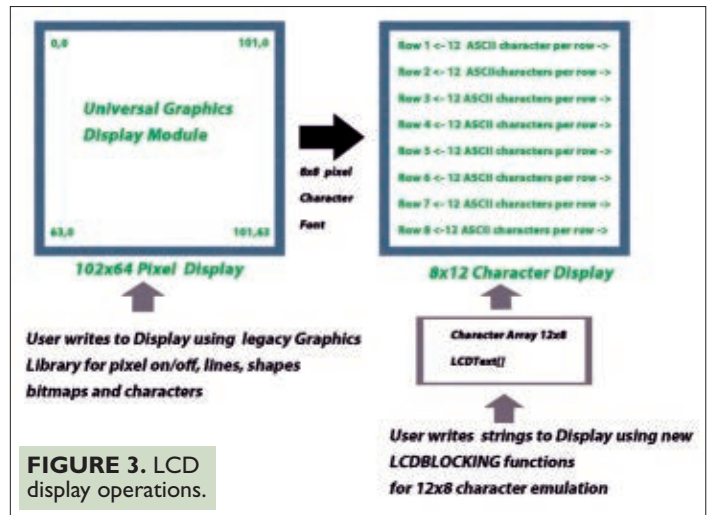

FIGURE 3. LCD display operations.

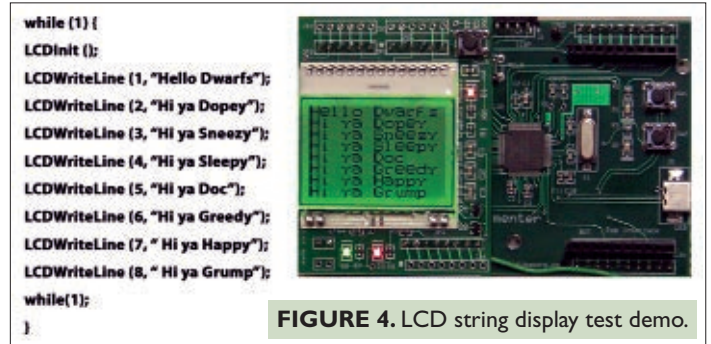

FIGURE 4. LCD string display test demo.

components that are pre-assembled. The module does come as a kit (available at www.nutsvolts.com). The only assembly requirement is to solder the display and backlight to the board, as well as the headers to the board.

The PS/2 Keyboard

A keyboard provides a powerful input capability for Experimenter applications. With the advent of USB keyboards, the PS/2 versions have pretty much been replaced, but still exist in large quantities and are available at low cost. First, we will discuss PS/2 operation and then how the Experimenter integrates to a PS/2 keyboard.

Historically between the PS/2 and the computer, there can be an extensive host-device protocol involved. For our purposes, we will simply stick to receiving key scan data from the keyboard, deciphering these key scans into ASCII, and then displaying this data on the Experimenter LCD display. We'll avoid any of the more difficult command features as they are not necessary for this terminal experiment.

Let's first examine the PS/2 physical interface. The PS/2 keyboard requires +5V to operate and generates its own data clock. PS/2 communications use a framed synchronous serial protocol to transfer data. The communication is "idle" when both lines (data and clock) are high (open-collector). This is the only state where the keyboard is allowed to begin transmitting data. The microcontroller has ultimate control over communications, and may inhibit communication at any time by pulling the clock line low. **Figure 5** shows the physical connector with

Keyboard physical interface

6-pin Mini-DIN (PS/2):

- 1 - Data
- 2 - Not Implemented
- 3 - Ground
- 4 - Vcc (+5V)
- 5 - Clock
- 6 - Not Implemented

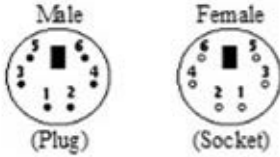

FIGURE 5. 5 PS/2 connector and pin assignments.

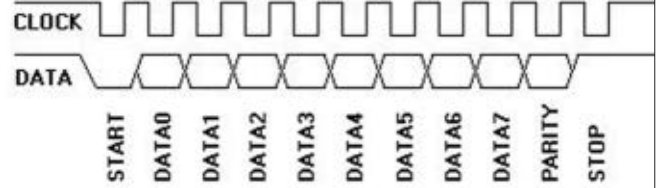

FIGURE 6. PS/2 serial data.

pin assignments used by the PS/2.

All data is transmitted “framed” one data byte at a time, and each data byte is sent in a frame consisting of 11-12 bits (see **Figure 6**). These bits are:

- One start bit. This is always 0.
- Eight data bits, least significant bit first.
- One parity bit (odd parity).
- One stop bit. This is always 1.
- One acknowledge bit (microcontroller to device communication only).

The parity bit is set (1) if there is an even number of 1s in the data bits, and reset (0) if there is an odd number of 1s in the data bits. This is used for error detection. Data changes during the clock high state, and is valid when the clock line is low. The baud (or bit) rate is not standard and can change from keyboard to keyboard. Typical clock frequencies can range from 10-16.7 kHz.

PS/2 Operation

There are a few things we need to do here to retrieve a key that is pressed on the PS/2 and then to display this key as a ASCII character on the Experimenter LCD.

First, the Experimenter needs to sample the PS/2 data line and clock line simultaneously and then determine when keyboard incoming data bits are valid. For the PS/2, the data valid condition occurs at the falling edge of the clock. We use the Experimenter PIC32 timer 4, as well as two of the PIC32 +5V tolerant digital inputs, to make this happen. The timer is run in an interrupt mode and configured fast enough to ensure that all clock edges are captured.

Here are some important specifics:

1. The PS/2 clock can be approximated as a square wave with a 50% duty cycle and a period of about 62.5 to 50 microseconds. If the timer 4 interrupt is set to sample every 25 microseconds, we are guaranteed during a timer 4 interrupt to get at least one sample of the PS/2 clock between falling and rising clock edges (good enough to capture an output PS/2 data sample).
2. Once a valid data sample is taken, it needs to be processed as a bit in context of the larger data frame. Once a total of 11 bits is captured, the frame needs to be validated for correct start, stop, and parity. If it passes this test, then it is a legitimate key scan code.

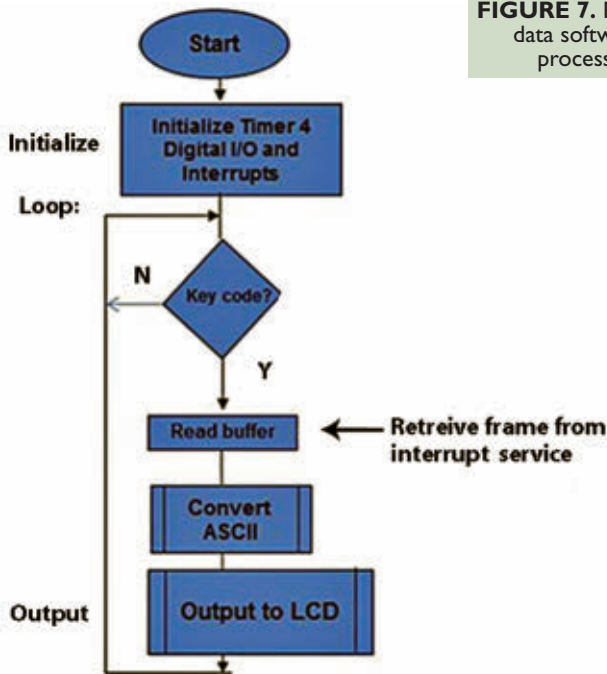
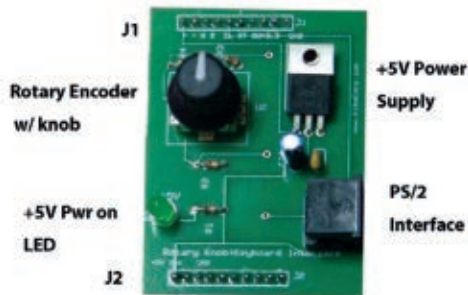

FIGURE 7. PS/2 data software processing.

Assembled Mini-Kit



J1 Pinout

- 1 + Raw Volts in > +6VDC
- 2 - Raw Volts ground
- 3. A out encoder
- 4. B out encoder
- 5. CL clock out PS/2
- 6. DAT data out PS/2
- 7. SW encoder switch
- 8. +3.3V in
- 9. not used
- 10. ground

J2 Pinout

- 1. +5 VDC out regulated
- 2. not used
- 3. ground
- 4-10 not used

Mini-Kit connected to PS/2 keyboard



FIGURE 8. Mini-kit.

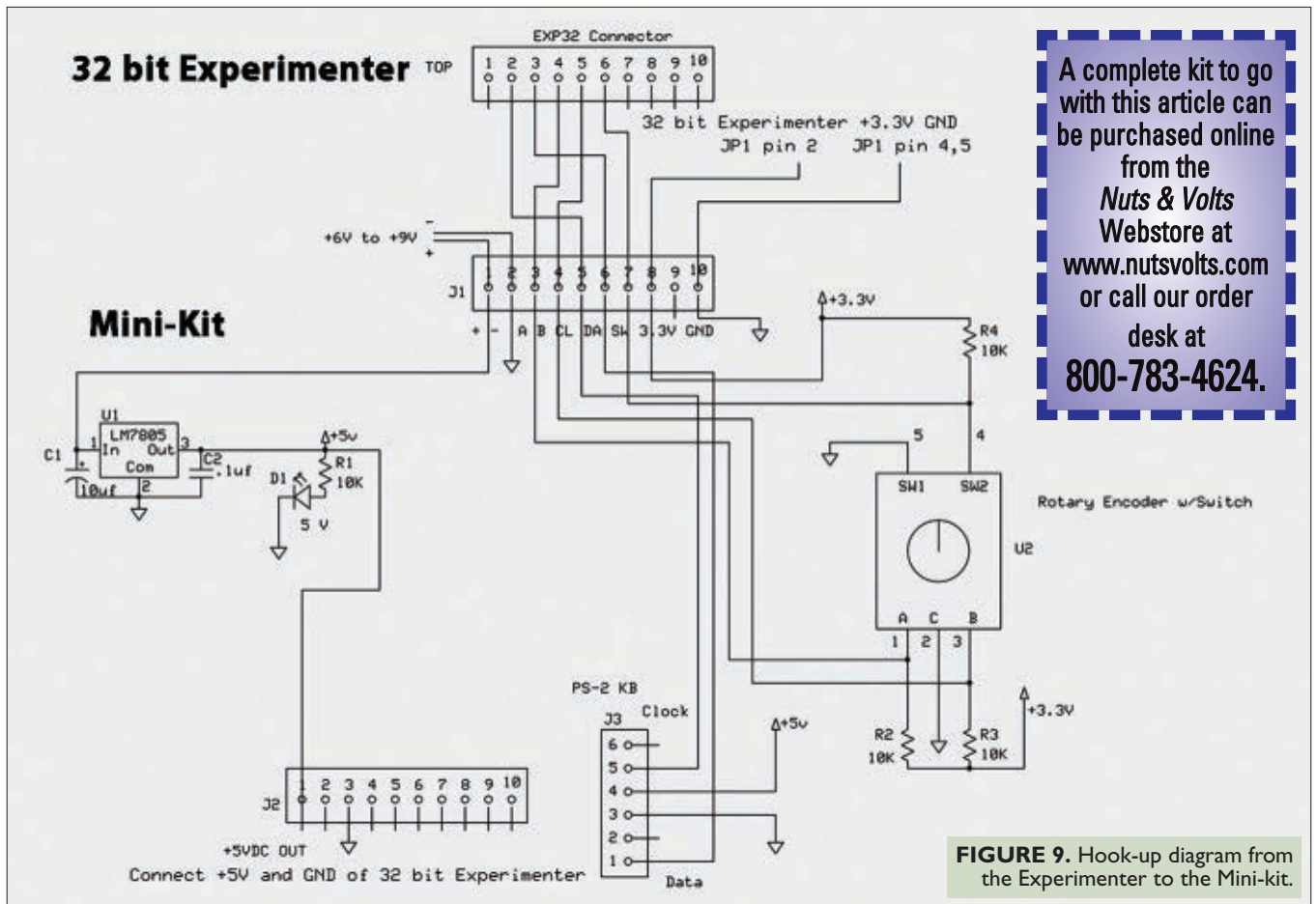

A complete kit to go with this article can be purchased online from the **Nuts & Volts Webstore** at www.nutsvolts.com or call our order desk at **800-783-4624.**

3. A key scan code is the raw scan data that represents the row and column position of the depressed or released key. It is generated by the PS/2 keyboard electronics as a result of scanning its matrix of 80-101 keys.

The final step in this process is to look up the corresponding ASCII representation associated with the key code. Once this is done, the key can then be displayed as ASCII on the LCD display. A flowchart of this operation is shown in **Figure 7**. The functional library elements for this component are:

- **void initKBD(void)** — Initialize timer interrupts, digital I/O, and global variables for PS/2 operation.
- **Char getcKBD(void)** — Retrieve and return valid ASCII codes as they have been received from the PS/2 keyboard. The KBDReady flag must be set to indicate that a valid key code has been received from the PS/2 keyboard. The current key code is processed into ASCII. KBDReady must be reset once the key has been processed.

The Mini-Kit

The Mini-kit was introduced in the Dec '10 *Nuts & Volts* article "Enhanced User Interface for the 16-bit Experimenter." It is recommended for use in this experiment because it provides a convenient small board format with all the necessary electronics and power supply (PS/2 keyboard interface and a +5V DC regulator) to integrate the PS/2

with the Experimenter. The kit also has an additional bonus in that it contains a rotary encoder knob that we can use for an additional data source (see **Figure 8**). We will experiment with both inputs. The +5V regulator is necessary to provide the required voltage levels for the PS/2 interface (to power up the keyboard and provide proper voltage levels for the PS/2 interface). Its 5V output is also available to the user to power up any external +5V hardware. As a side note, if you intend to use the Experimenter from an unregulated supply, consider using the Mini-kit +5V regulator output for the Experimenter. The hook-up diagram shows this.

The Experimenter itself is a +3.3V device but has +5V tolerant lines that are available for connecting and sampling the PS/2 data and the clock. Recommended hook-up lines are shown in **Figure 9**.

Keyboard Demo

Once you've completed the integration of the Mini-kit to the Experimenter hookups (as per **Figure 9**), proceed to the keyboard demo. Open the keyboard folder and then invoke workspace Keyboard.mcp. Compile and program/download this workspace into the Experimenter. You should see the start up screen as shown in **Figure 10**. This screen times out to a blank screen that accepts any characters typed in from the PS/2 display. Typing beyond the limits of the LCD display will cause the characters to wrap around, starting at the initial display position of 0,0. The F10 key will clear the display and be in position for a new character

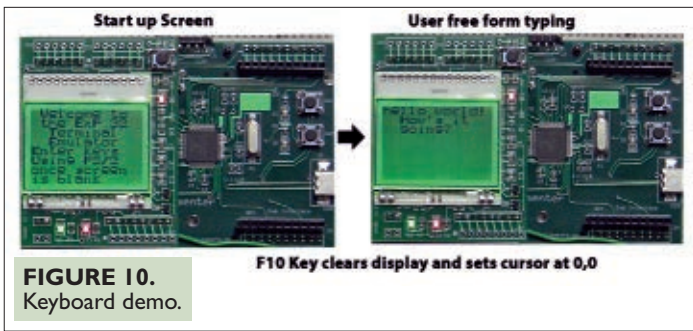

JP2, and +3.3V and GND pins 2 and 4 (or 5) of Experimenter JP1. (Note the hook-up diagram in **Figure 11**.) To facilitate solderless board connection, use two .1" four-pin headers soldered together at a right angle to connect the interface to the board. The serial port library functions used in the data logger are:

- **initU3()** — Initializes the serial port using UART3 of the PIC32 for 19200 baud, eight-bit data, no parity, and one stop bit (or shorthand 19200N1).
- **putU3(character)** — Writes ASCII characters out to the serial port.
- **putsU3(string)** — Writes an entire ASCII string out to the serial port.
- **Character getU3()** — Waits for a new ASCII character to arrive at the serial port and returns it.

A demo test program is provided in the downloads. First, you must configure your PC with HyperTerminal for communication at 115200 baud, eight bits, no parity, one stop (115200 8N1). Follow the steps shown in **Figure 12**. The other setting is to configure the communications for VT100. With the VT100 configuration, we can issue escape codes to clear the HyperTerminal screen and return the cursor to the home position. In this way, we can mimic the LCD display operations with the F10 key.

Open the serial folder and then invoke workspace Serial.mcp. Compile and program/download this workspace into the Experimenter. You should now be able to type on the PC keyboard and see the results displayed on the Experimenter LCD.

Final Terminal Emulation Step

Let's complete the terminal application by integrating all the diverse components into a cohesive whole. At this point, all the individual pieces should be integrated and tested by the following checklist:

1. LCD 12x8 — Hook up the universal module and run LCDtest.MCP.
2. Mini-kit — Assemble and hook up.
3. PS/2 — Use assembled/connected Mini-kit; connect the PS/2 keyboard and run Keyboard.mcp.
4. Serial Port — Hook up the ACRONAME interface and run Serial.mcp.

Once you have successfully integrated and tested all the components, is it now time to run the final terminal application. Open the folder terminal.mcp, and build and download code into the Experimenter.

For the final test, we should be able to type on the PS/2 interface and see updates to both the LCD interface and the PC HyperTerminal window simultaneously. Examples are shown in **Figure 13**.

What About Rotary Inputs?

The other Experimenter input associated with the

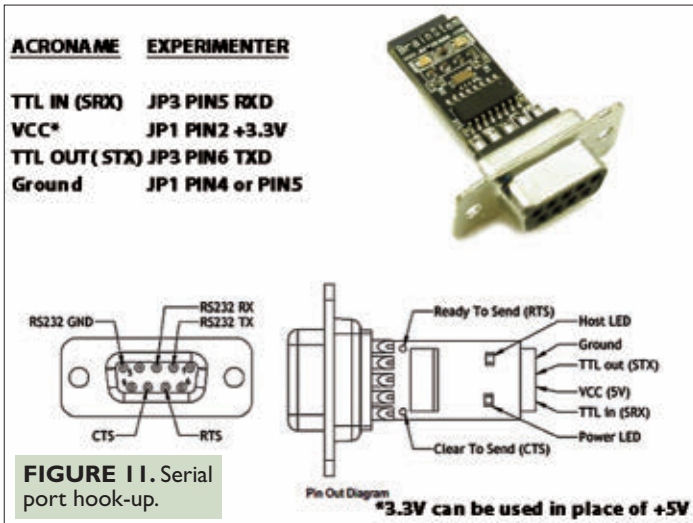

FIGURE 11. Serial port hook-up.

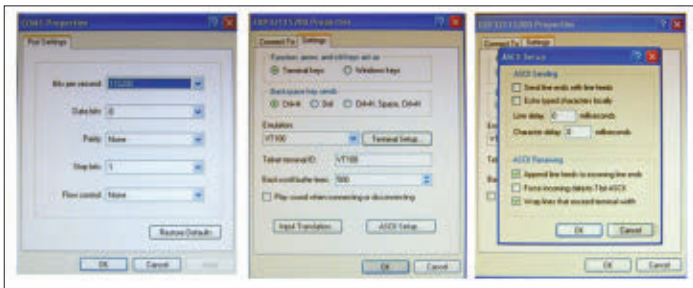

FIGURE 12. HyperTerminal setup.

at 0,0. Upon completion, you should be able to type on the keyboard and have the keyboard characters appear on the Experimenter LCD module (if one is present). Congratulations! You have a working PS/2 interface!

Serial RS-232 Port

Let's continue with our integration for the terminal application. To connect the Experimenter to a PC, a serial port is required. The port uses one of the five possible internal UARTs that are available with the PIC32.

The serial port can drive a PC serial RS-232 port only when the proper physical interface is made available. As a reminder, the PIC32 serial port is +3.3V to 0V out; RS-232 requires a +12 to -12 volt communication. The ACRONAME serial interface connector (www.acroname.com) provides an ideal physical interface and is pretty inexpensive. The ACRONAME interface is shown in **Figure 11**.

There are only four connections needed to work with the Experimenter. They are pins 1 and 2 of Experimenter

Mini-kit is the rotary encoder. Let's incorporate that into our terminal emulation. The rotary encoder theory and operation were covered in detail in the Dec '10 issue article "Enhancing the User Interface With the 16-Bit Experimenter." The lessons learned there still apply here.

With a rotary encoder, the Experimenter can determine rotation direction and amount of rotation. These two physical phenomena can be used as an operator input. In this demo, we will use the rotary encoder rotations and direction to display a string on both the LCD display and HyperTerminal screen simultaneously. The PS/2 keyboard inputs will not be used. No change in hardware is required if the earlier hook-up diagram provided is followed.

Open the terminal folder and then invoke workspace rotary.mcp. Compile and program/download this workspace into the Experimenter. Results should appear as shown in Figure 14.

What's Next

We have now successfully integrated all the required functional components to realize a legacy communication operation with the 32-bit Experimenter. There are a number of components that can be used for other applications. At a later time, we'll show you a USB application that essentially does the same function but without the legacy RS-232. Until next time, happy 32-bit computing! **NV**

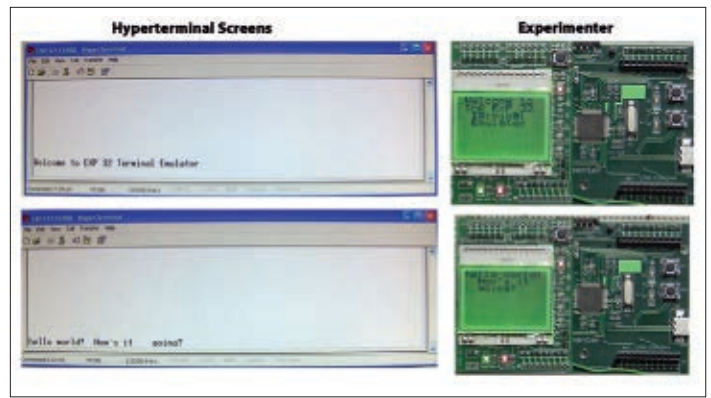

FIGURE 13. Terminal emulation demo.

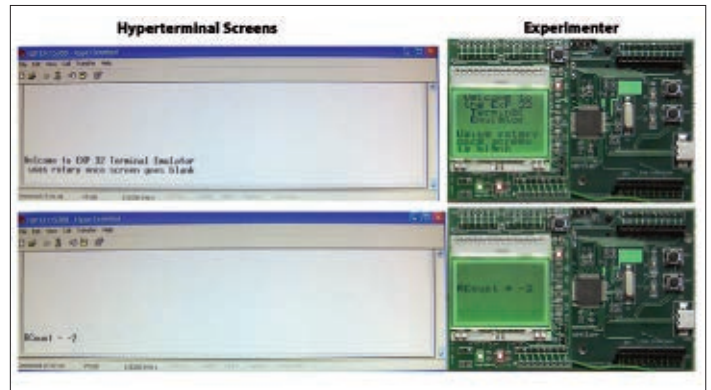

FIGURE 14. Rotary operations.

*** Quality Quick Turn Sheet Metal Products & Precision Machined Parts**

*** No Minimum Quantity Restrictions**

*** Quote in 24 Hours or Less!**

*** Several Metallic & Non-Metallic Materials in Stock**

Visit www.iitmetalfab.com today for your free, no obligation quote!

Integrated Ideas & Technologies, Inc.

ITAR Compliant ISO 9001:2008 AS 9100 Certified

Precision Laser Cut Stencils Sheet Metal Fabrication Precision Parts Manufacturing

Defense Aerospace Medical Aviation Communications Maritime Electronics

Serving All Industries

Metal Fabrication: www.iitmetalfab.com SMT Stencils: www.integratedideas.com

■ BY FRED EADY

INVASION OF THE CHIPKIT MAX32

With the introduction of the Arduino-speaking chipKIT Max32, about the only world-changing thing left for me to see in my lifetime is the arrival of aliens. There have been lots of intrusions into AVR-controlled Arduino airspace. However, the arrival of the 32-bit Microchip flagship microcontroller in the Arduino sector is akin to the Vulcan scout ship T'Plana Hath's first contact on Earth.

FIRST CONTACT

The chipKIT Max32 parked in **Photo 1** is capable of quickly ferrying Arduino shield payloads with minimal or zero modifications. The chipKIT Max32's warp drive is based on a Microchip PIC32MX795F512L 32-bit microcontroller clocked at 80 MHz. The PIC32MX795F512L is rich in on-chip peripherals. However, external components to support its on-chip peripherals are only required when a particular peripheral is put into use. For instance, the PIC32MX795F512L supports Ethernet and CAN. If you do not need Ethernet capability, the Ethernet PHY IC need not be mounted. The same goes for CAN. There is no need to include the MCP2551 CAN transceiver if the PIC's internal CAN hardware is to remain idle in your application.

Arduino is a programmer's paradise that shields the complexities of the hardware from the programmer. To that end, a specially modified Multi-Platform IDE (MPIDE) has been developed to assist in chipKIT Max32 sketch development. However, most "programmers" these days are also interested in what they are loading their precious code into. With that, we're going to board that chipKIT Max32 you see in **Photo 1** and check out the instrumentation.

The chipKIT Max32's controlling microcontroller needs no introduction. The PIC32MX795F512L is the biggest, baddest, fastest microcontroller in the PIC family of devices. Every logical embedded peripheral a designer would need

for an embedded application is integrated into the PIC32MX795F512L's silicon fabric.

This silicon embeds an intense USB subsystem. Thus, it would be logical to ascertain that the PIC32MX795F512L has no need for any help from an external USB-enabling peripheral IC. So, why is there an FTDI FT232RQ standing behind the chipKIT Max32's Mini-B USB connector? Answer me this. Does your brand new laptop have a nine-pin male RS-232 connector? The correct answer is "nope." Okay. Does your brand new laptop have a USB connector? The answer is "Yep. More than one." An RS-232 portal may not be physically mounted on your PC frame, however, RS-232 is not totally dead yet. So, if you don't have a regulation RS-232 interface on your laptop, how do you establish RS-232 type connectivity? Easy. You use one of the USB portals and a COM port driver. Okay. Then, why is that FTDI FT232RQ mounted on the chipKIT Max32 printed circuit board (PCB)? The answer lies in **Schematic 1**. Note that the FT232RQ's TXD and RXD signal lines are physically tied to the PIC32MX795F512L's UART1 pins.

The chipKIT Max32's FT232RQ-based USB portal serves a dual purpose. From a communications standpoint, the Max32's USB portal provides a data path between the PIC and the MPIDE. Power for the Max32 can also be derived from the USB connection. Data activity is visually indicated by a pair of LEDs that sit directly behind the RESET button.

The only other remarkable support components onboard the Max32 are the power supply electronics. The chipKIT designers took a page from the Vulcan play book. If it works and it has worked for a very long time, continue to use it. The 5.0 volt regulator in **Schematic 2** is a descendant of the caveman LM317 adjustable voltage regulator. In the case of the Max32, the Jetsons NCP1117 variant is a fixed voltage adaptation of its LM317 predecessor. The NCP1117's

■ **PHOTO 1.** It really doesn't matter if you lean towards Arduino or not. The chipKIT Max32 can work in the Arduino environment or fall back on its Microchip MPLAB/C32 C compiler roots. Either way, you have direct access to the resources of Microchip's most powerful microcontroller.

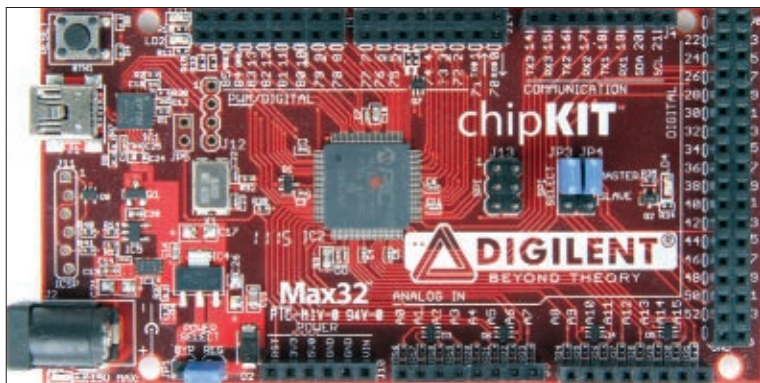

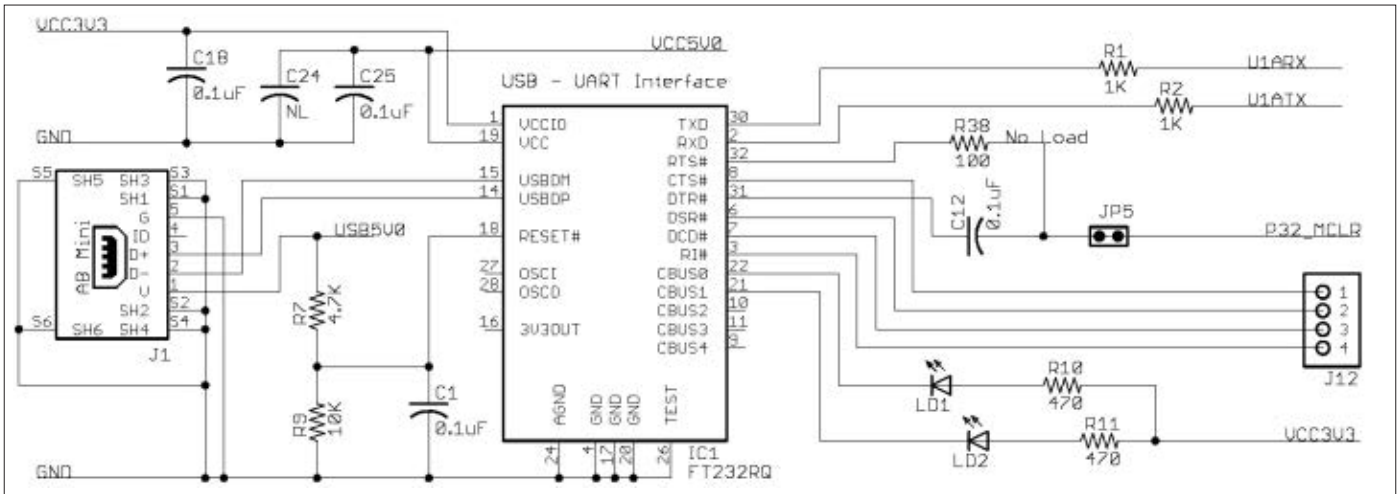

■ SCHEMATIC 1. There's no reason to put a regulation nine-pin RS-232 interface here if your PC has to be adapted to use it. The inclusion of the FT232RQ and a physical USB interface is a perfectly logical choice.

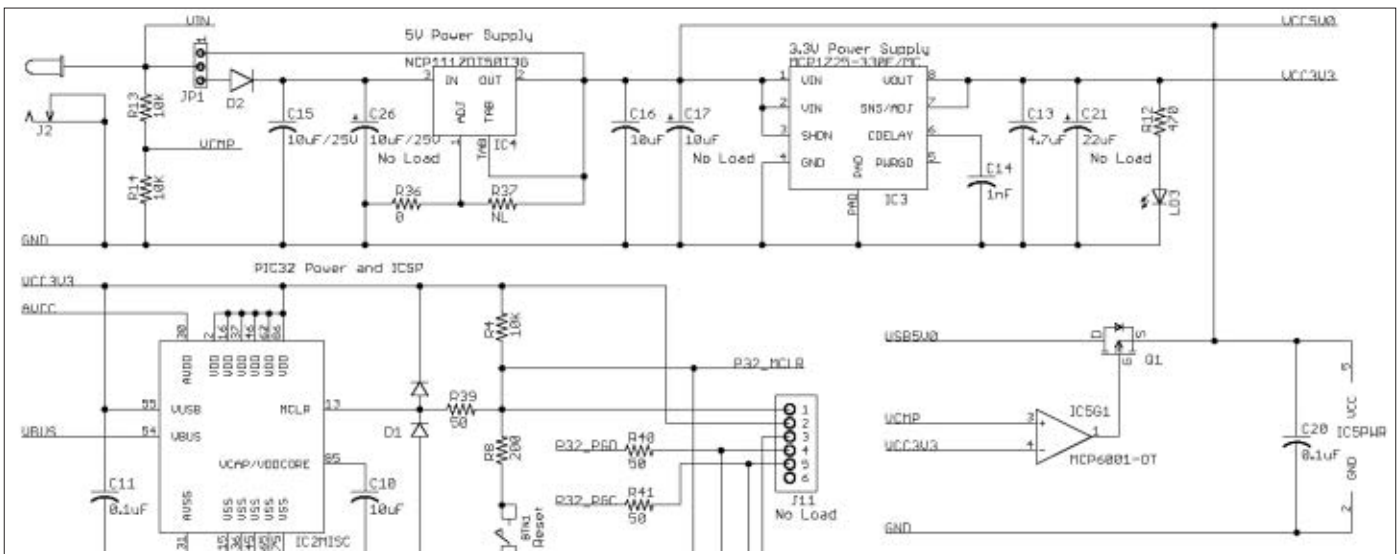

■ SCHEMATIC 2. You can feed the NCP1117 from a wall wart or bypass it all together. The idea is five volts in and 3.3 volts out no matter what.

job is to bring the raw chipKIT Max32 input voltage (7 to 15 VDC) down to an acceptable level (under six volts) for the MCP1725. The NCP1117 is a low dropout version of the standard LM317 and has a lower dropout voltage than its contemporary, the LM1117. In addition, the NCP1117 can supply 1.0 amperes of current versus the 800 mA offered by the LM1117. The “MCP” tells us that the 3.3 volt MCP1725 low dropout voltage regulator is a Microchip product. The MCP1725’s entourage includes a minimum of relatively small and inexpensive stabilizing components. In fact, capacitors C17, C21, and C26 in **Schematic 2** are not mounted on the chipKIT Max32 PCB. The big picture is to use the NCP1117 to drop the input voltage to an acceptable level for presentation to the MCP1725 which will provide a very stable 3.3 volts at up to 500 mA for the Max32’s PIC32MX795F512L and 3.3 volt peripherals.

The NCP1117’s role depends on you. You can feed the NCP1117 from a wall wart, an external power supply, or totally ignore it by way of the POWER SELECT jumper. The

5.0 volts supplied by the NCP1117 to the MCP1725 can also be usurped by a host PC’s USB portal. As you can see in **Schematic 2**, a Microchip MCP6001 comparator samples the voltages presented at the VCMP voltage divider junction and VCC3V3 output of the MCP1725. The output of the MCP6001 comparator drives the gate of a P-channel MOSFET which blocks or passes the USB portal’s 5.0 volts to the VCC5V0 output. The comparator hookup makes sure that the external input voltage always wins the power sourcing battle when a USB power source is attached. If you’re wondering why we need +5.0 volts other than to feed the MCP1725, it’s the shields, Scotty, the shields. Many of the native AVR-based shields want to see a 5.0 volt power source. The chipKIT Max32 is designed to be compatible with Arduino shields. The Max32 digital I/O pins are five volt tolerant. However, the PIC32MX795F512L’s analog-capable pins are not five volt tolerant. To keep the magic smoke contained within the PIC silicon, every PIC analog-capable pin is protected by a clamp diode and

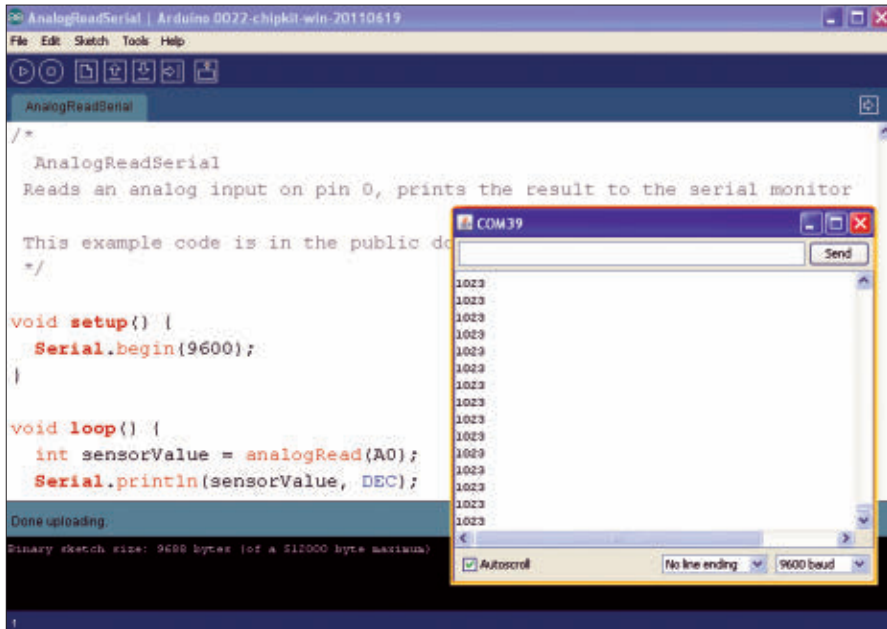

■ **SCREENSHOT 1.** A jumper between the chipKIT Max32's A0 analog-to-digital input and +3.3 volts maxes out the PIC32MX795F512L's 10-bit analog-to-digital converter.

current limiting resistor. Regardless of the protection, the maximum analog input voltage remains at +3.3 volts. Scanning the Max32 landscape does not reveal any Area 51 PIC32MX795F512L programming hardware. Instead, the standard set of six ICSP pads lie between the power connector and USB Mini-B interface. The ICSP pads are configured to interface directly to a PICkit3 programmer/debugger. If you accidentally find a way to eliminate the factory-loaded bootloader, the ICSP pads and an external PIC32MX795F512L programmer are the only way to reload the bootloader code. The ICSP portal is also your door to loading and debugging your home-grown PIC code.

The Max32 physically presents us with 83 I/O pins, 16 analog inputs, a 10 Mbps/100 Mbps Ethernet MAC, a USB 2.0 Full Speed OTG (On The Go) controller, a pair of CAN controllers, RS-232 modem control handshaking signals (DCD, CTS, etc.), an SPI portal interface, and a power portal. The length of the Max32 I/O access list translates into a gaggle of associated I/O pins and female headers. Fortunately for us, the Arduino boilerplate logically sorts them all out for us. The Max32 provides female headers that supply power to the shields and establish data paths between the shield electronics and the PIC32MX795F512L. The Arduino system dictates that the Max32 I/O pins range from zero to 85. Each I/O and analog input is clearly identified by silkscreen legend. We've walked around, on, and over most every major component that comprises the base chipKIT Max32. It's time to take our Max32 out of space dock and do some maneuvering.

OUT-OF-THE-BOX ARDUINO

Your Max32 will come preloaded with a bootloader

and a simple LED blinker application. I grew out of the LED blinker program rather quickly and decided to try out the MPIDE and Max32 with a simple analog-to-digital (A-to-D) application. So, I started the MPIDE, selected the Max32 as my target platform, and loaded the AnalogReadSerial example sketch.

Arduino is an intuitively obvious system. So, I won't insult your intelligence with a blow-by-blow description of how I loaded and ran the example program. Everything you need to see concerning my test run is displayed in **Screenshot 1**. I placed a jumper between the Max32's A0 A-to-D input and the 3.3 volt power pin on J10. The PIC32MX795F512L's A-to-D subsystem has 10 bits of resolution, and the 1023 decimal (0x3FF) result is what one would expect to see. I used the MPIDE's serial monitor tool to display the

A-to-D readings in **Screenshot 1**.

Running those simple Arduino demos was enough to convince me that the PIC32MX795F512L could truly speak Arduino. I'll leave it to you to experiment with the Max32 at this level. If you're new to Arduino or the PIC32MX795F512L, I suggest stopping here, whipping out your Max32 hardware, firing up your copy of MPIDE, and doing some getting acquainted. You'll find lots of Max32-adapted Arduino example code within the MPIDE framework. Once you get comfortable with the Max32 and Arduino, you can pick up and continue from here.

THE ULTIMATE chipKIT Max32 SHIELD

Back in my corporate days, I was the communications specialist for our sales team. My sales pitches were purely technical and focused on the importance of setting up and maintaining a robust data network. I would always emphasize the point that no matter how big, how fast, or how expensive the CPU was, it was a useless piece of junk if it could not communicate with its peers and slaves via some sort of network. The same axiom holds true for small embedded devices like the Max32. With that networking thought in mind, get an eye full of **Photo 2**. Recall that Ethernet PHY IC we mentioned earlier? It's here. Remember that pair of MCP2551 CAN transceivers that were needed for the Max32 to participate in a CAN network mount? They're here too. The chipKIT Network Shield is an extension of the PIC32MX795F512L's internal communications subsystems. By fitting the Network Shield to the Max32's female headers, we gain total access to the PIC32MX795F512L's 10 Mbps/100 Mbps Ethernet engine and its CAN networking subsystem. The Ethernet PHY is made up of an SMSC LAN 8720 PHY IC and a Bel Stewart MagJack. The chipKIT Network Shield sources everything the PIC32MX795F512L's Ethernet MAC requires, right down to the 25 MHz crystal. The Ethernet

■ PHOTO 2. The chipKIT Network Shield complements the PIC32MX795F512L's internal communications subsystems by providing the physical means to access them.

PHY portion of the Network Shield is graphically depicted in **Schematic 3**.

The MCP2551 CAN transceiver circuits are inked in **Schematic 4**. Note that the transceivers require a +5.0 volt supply. If you're CAN challenged, those 120Ω resistors are CAN termination resistors. The termination resistors reside at each end of the CAN network. Portals for accessing the I²C bus and an onboard 24LC256 I²C EEPROM are also revealed by the installation of the Network Shield. If you plan to use your Shield in an I²C network, you must use bus pull-up resistors in accordance with the I²C specification. Note the 2.2KΩ pull-up resistors on the 24LC256 SCL and SDA lines in **Schematic 5**.

To utilize the PIC32MX795F512L's internal RTCC (Real Time Clock Calendar), all we really need from a hardware point of view is a 32.768 kHz clock source. The Network Shield is loaded with a 32.768 kHz crystal oscillator which we can use to keep up with the time and date. The Network Shield is equipped with a pair of USB interfaces. The Max32 can be configured as a USB host, a USB device, or a USB OTG device. When configured to act as a USB host, the Network Shield must have a means of supplying +5.0 volts at the USB host interface. Take a look at **Schematic 6**. The TPS2051B is a solid-state power switch that is under the control of the Max32's VBUSON signal. When the TP2051B's EN input is logically high, VCC5V0 flows to the TP2051B's OUT pin. The TP2051B's OUT pin voltage is manually directed to one of the USB interfaces via a jumper. An overcurrent condition is reported to the PIC32MX795F512L via the TP2051B's active-low OC pin. We've established one thing for certain: the Max32 loaded with a Network Shield is

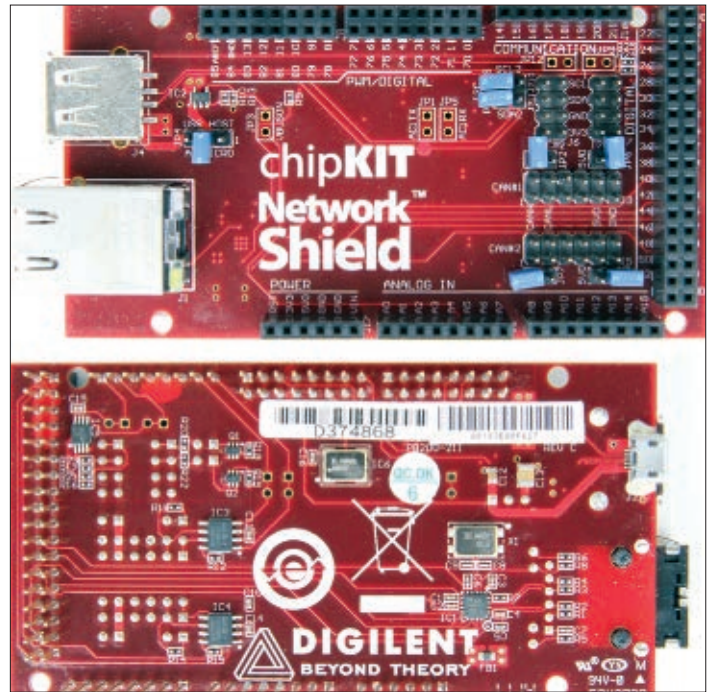

definitely not a piece of junk. The Max32/Network Shield combination has the ability to communicate with most any embedded or cloud-based computing platform. The Max32 can even talk to your car.

BILINGUAL SILICON

The Max32 was designed to support Arduino with a Microchip 32-bit microcontroller. However, the Max32 and the Network Shield combine to form a perfect PIC development platform. If you want to use the Max32 as a development tool, you'll need to take control of the

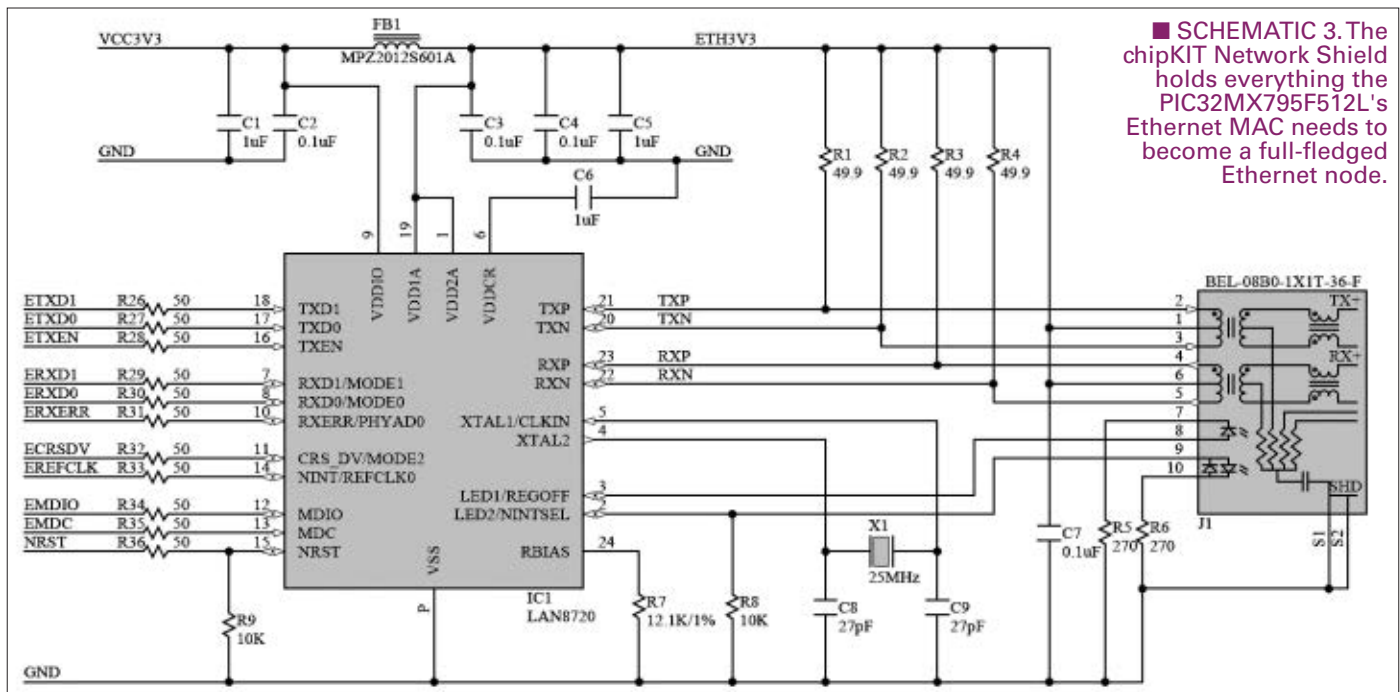

■ SCHEMATIC 3. The chipKIT Network Shield holds everything the PIC32MX795F512L's Ethernet MAC needs to become a full-fledged Ethernet node.

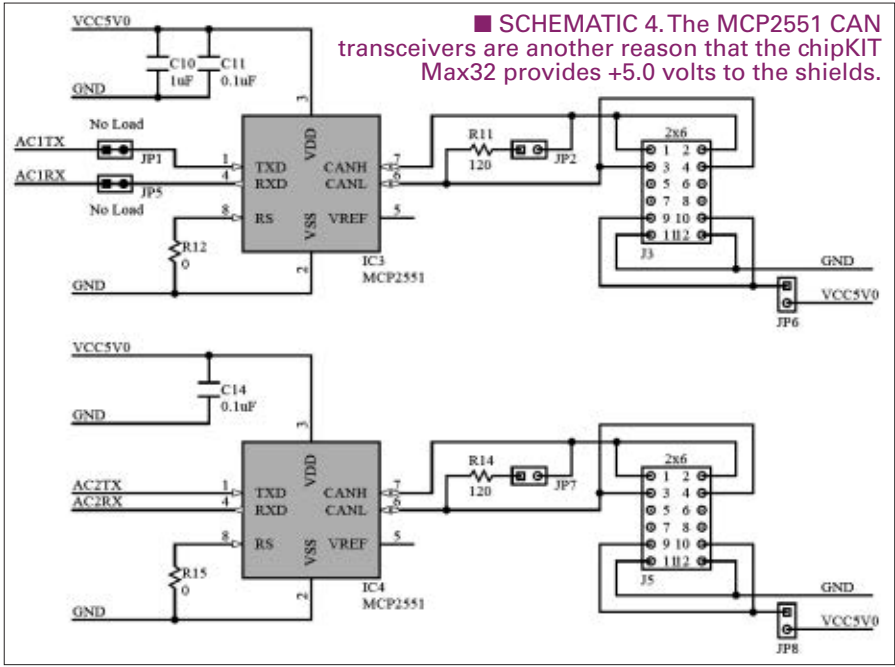

Loosely translated, the PIC32MX UART Peripheral Library serial transmit looks like this Arduino statement:

```
Serial.write(0x55);
```

Odds are if you need to transmit, you may also need to receive. In Arduino speak, receiving data is as easy as:

```
int character;
if (Serial.available() > 0)
{
  character = Serial.read()
}
```

Like the Arduino receive code, the Peripheral Library mnemonics are an easy read. There isn't much difference between the Arduino and the Peripheral Library code. As far as the PIC32MX795F512L is concerned, if you can code in C, you can code in Arduino, and vice versa:

Max32's FTDI-based USB portal. We'll do this using the PIC32MX UART peripheral library. The Arduino `Serial.begin(9600);` translates to this PIC32MX UART Peripheral Library snippet:

```
#define GetSystemClock()          80000000UL
#define GetPeripheralClock()      40000000UL
#define GetInstructionClock()    (GetSystemClock() / 2)

UARTConfigure(UART1A,
UART_ENABLE_PINS_TX_RX_ONLY);
UARTSetLineControl(UART1A, UART_DATA_SIZE_8_BITS
| UART_PARITY_NONE | UART_STOP_BITS_1);
UARTSetDataRate(UART1A, GetPeripheralClock(),
9600);
UARTEnable(UART1A, UART_ENABLE_RX_TX);
```

The PIC32MX UART Peripheral Library mnemonics are self-commenting and are as easy to read and follow as an Arduino sketch. Now that we have the Max32 UART's attention, sending a byte (0x55) of data is as easy as:

```
if(UARTTransmitterIsReady(UART1A))
{
  UARTSendDataByte(UART1A, 0x55);
}
```

```
UINT8 character;
if(UARTReceivedDataIsAvailable(UART1A))
{
  character = UARTGetDataByte(UART1A);
}
```

Whether they are legacy RS-232 or USB-based, serial portals are staples in embedded computing. So, it's no surprise that Arduino has a strong set of serial routines in its bag.

Some of the Max32 peripherals cannot be accessed bilingually using C and Arduino. However, at this very moment, there are guys and gals out there porting more and more PIC32MX code to the Arduino platform.

THE chipKIT Max32 AND THE MICROCHIP APPLICATION LIBRARIES

I decided to throw caution to the wind and load up my Max32 with a Microchip Application Libraries thumb drive application. Using my PICkit3, I blew up the Max32 factory bootloader and replaced it with the Mass Storage simple demo which is part of the Application Libraries.

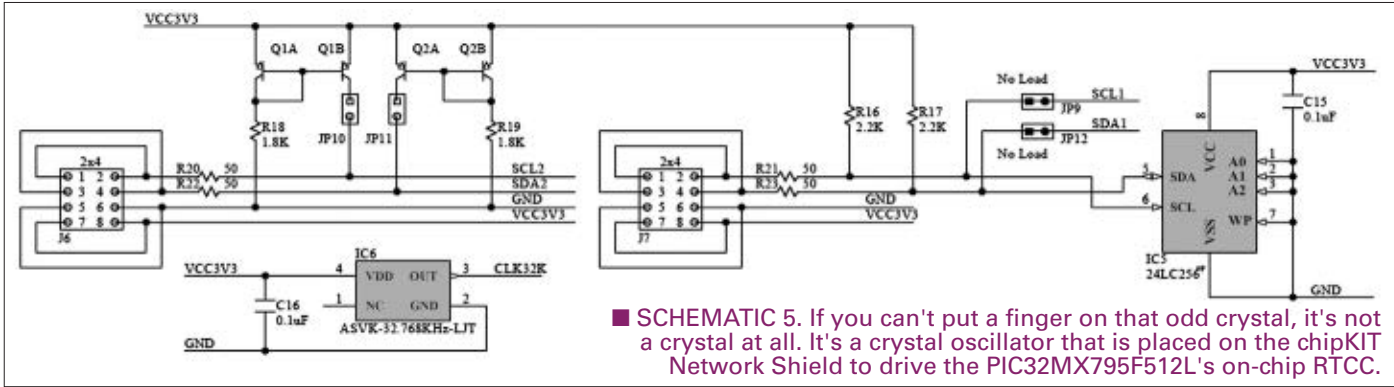

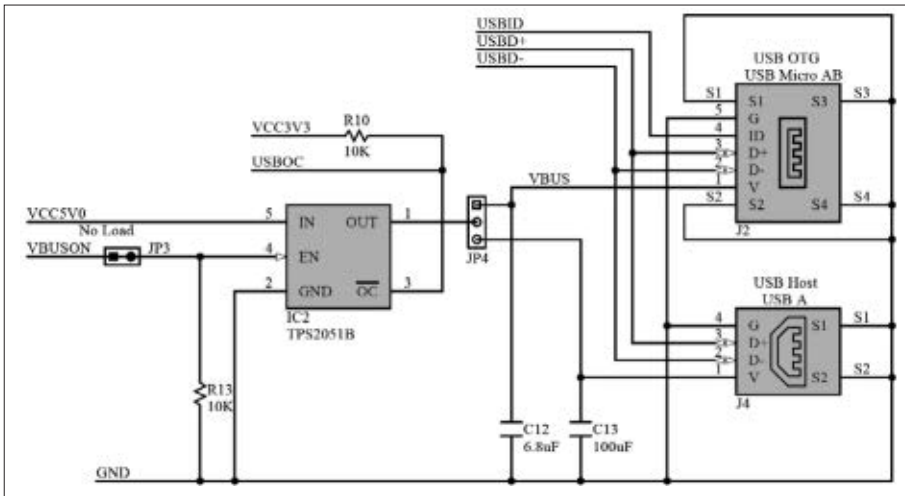

■ **SCHEMATIC 6.** The PIC32MX795F512L contains all of the USB interface circuitry. All that we need to supply are the physical connectors. If our chipKIT Max32 is to act in the USB host capacity, throw in a switchable +5.0 volt power source with those connectors.

Here's the heart of the application:

```
//Opening a file in mode "w" will create the file if it
// doesn't exist. If the file does exist it will delete
// the old file and create a new one that is blank.
myFile = FSfopen("test.txt", "w");

//Write some data to the new file.
FSfwrite("Bringing Arduino to the PIC32MX with chipKIT
Max32", 1, 50, myFile);

//Always make sure to close the file so that the data gets
// written to the drive.
FSfclose(myFile);
```

My contribution to the Mass Storage application is rather obvious. Before compiling the Application Libraries thumb drive code, I set the USB host power jumper to feed the larger Type A USB connector on the Network Shield and plugged the Shield into the Max32. I used the Max32's Mini-B USB portal to power the Max32/Network Shield combination from my laptop's USB portal. Next, I opened the Mass Storage application with MPLAB, attached a PICkit3 to the Max32, and compiled the thumb drive application using Microchip's C32 C compiler. The Application Libraries Mass Storage application is bare bones and doesn't give any indication that it is working or not. However, when I attached the thumb drive to the Network Shield's Type A USB connector, the thumb drive's activity LED began to blink. After a few moments, the thumb drive's activity LED ceased to blink and remained illuminated. So, I detached the thumb drive and inserted it into my laptop's USB portal. Sure enough, there was a file created on the thumb drive called *test.txt*. I opened *test.txt* with a text editor application to find that the file contained the following: Bringing Arduino to the PIC32MX with chipKIT Max32. Enough said.

MORE chipKIT Max32 ARDUINO STUFF

We've shown the Max32 and Network Shield for what they are: excellent development tools for both Arduino and native 32-bit PIC32MX applications. If you've been on the fence about a Microchip presence in AVR land, check out the chipKIT Max32 forums. I think you'll be pleasantly surprised. You can access the chipKIT forums and purchase your Max32 equipment from the Digilent website (www.digilent.com).

Meanwhile, I've got some Arduino-to-chipKIT Max32 porting to do! **NV**

POSCOPE MEGA 1+

IT'S OSCILLOSCOPE!
IT'S SPECTRUM ANALYSER!
IT'S DATALOGGER!
IT'S RECORDER!
IT'S LOGIC ANALYZER!
IT'S PATTERN GENERATOR!
IT'S SIGNAL GENERATOR!

POKEYS

WWW.POSCOPE.COM

IT'S KEYBOARD EMULATOR!
IT'S JOYSTICK EMULATOR!
IT'S USB OR ETHERNET!
IT'S MODBUS AND TCP!
CAN DRIVE LCDS, LED MATRICES...
CAN READ ENCODERS,
KEYBOARD MATRICES.
CAN HANDLE MORE THAN 300 IOS
MATLAB, LABVIEW, C#, VB.NET, VB6.0
AND DELPHI EXAMPLES.

Europe's leading prototype supplier now also in America

Order direct from our US facility!

PCB-POOL RULES!

DAS ORIGINAL SEIT 1994
PCB-POOL[®]
Beta LAYOUT

order!
PCBs 1-6 layers

free!
Free Stencil

fast!
8 hour service

NEW!

cool!
Aluminium-Core IMS PCBs

Beta
LAYOUT

www.pcb-pool.com

email : sales@beta-layout.us
Toll Free USA : 888-977-7443

All registered brands remain the registered trademarks of the respective manufacturer!



I₂I CONTROLS

Tomorrow's programming revolution,
starts today!

The choice is yours to make

```
//-----  
*  
SSD1963_8-BIT  
PROGRAM FOR WRITING TO NE-  
WHAVEN DISPLAY 5.7" TFT  
*/  
//-----  
DELAY_MS(100);  
WRITE_COMMAND(0x01); //SOFTWARE RESET  
WRITE_COMMAND(0x01);  
WRITE_COMMAND(0x01);  
DELAY_MS(10);  
COMMAND_WRITE(0x0E,0x01); //START PLL  
COMMAND_WRITE(0x0E,0x03); //LOCK PLL  
WRITE_COMMAND(0x80); //SET LCD MODE SET TFT 18BITS  
MODE  
WRITE_DATA(0x0C); //SET TFT MODE & HSYNC+VSYNC+DEN  
MODE  
WRITE_DATA(0x80); //SET TFT MODE & HSYNC+VSYNC+DEN  
MODE  
WRITE_DATA(0x01); //SET HORIZONTAL SIZE=320-1 HIGH-  
BYTE  
WRITE_DATA(0x3F); //SET HORIZONTAL SIZE=320-1 LOWBYTE  
WRITE_DATA(0x00); //SET VERTICAL SIZE=240-1 HIGHBYTE  
WRITE_DATA(0x0F); //SET VERTICAL SIZE=240-1 LOWBYTE  
WRITE_DATA(0x00); //SET EVEN/ODD LINE RGB SEQ.=RGB  
COMMAND_WRITE(0xFO,0x00); //SET PIXEL DATA I/F  
FORMAT=8BIT  
COMMAND_WRITE(0x3A,0x60); // SET R G B FORMAT = 6 6 6  
WRITE_COMMAND(0xE6); //SET PCLK FREQ=4.94MHZ ; PIXEL  
CLOCK FREQUENCY  
WRITE_DATA(0x02);  
WRITE_DATA(0xFF);  
WRITE_DATA(0xFF);  
WRITE_COMMAND(0xB4); //SET HBP,  
WRITE_DATA(0x01); //SET HSYNC TOTAL 440  
WRITE_DATA(0xB8);  
WRITE_DATA(0x00); //SET HBP 68  
WRITE_DATA(0x44);  
WRITE_DATA(0x0F); //SET VBP 1.6=1.5+1  
WRITE_DATA(0x00); //SET HSYNC PULSE START POSITION  
WRITE_DATA(0x00);  
WRITE_DATA(0x00); //SET HSYNC PULSE SUBPIXEL START POSI-  
TION  
WRITE_COMMAND(0xB6); //SET VBP,  
MORE
```



```
; USING NEWHAVEN DISPLAY  
WITH SSD1963 CONTROLLER
```

```
; DO DATE AND TIME
```

```
SETIO G, 0XFO00 ;SET LOCATION FOR DISPLAY  
SETIO U, 0XFA00 ;SET LOCATION FOR USB DRIVE  
LOAD "FONT.HEX" ;GET FONT TABLE FROM USB  
SETGLCD I ;INITIALIZE THE GRAPHICS LCD  
SETGLCD C ;CLEAR THE DISPLAY  
SETGLCD D1 ;SELECT LARGE FONT
```

```
DO
```

```
SETGLCD P,(100,200);SET CURSOR POSTION
```

```
; DISPLAY TIME
```

```
GLCDOUT USING(2),!H,"",!M,"",!S," "
```

```
; DISPLAY DATE
```

```
GLCDOUT USING 2),!MO,"",!D,"",!Y
```

```
UNTIL S=1
```

```
; ALL DONE
```

Choose your path at



www.i2icontrols.com



■ BY LOUIS E. FRENZEL W5LEF

WHATEVER HAPPENED TO CITIZENS BAND RADIO? Wireless Throwback Or Still A Viable Communication Alternative?

I was talking with some friends about ham radio and some other wireless communications methods recently and someone asked, “Whatever happened to Citizens Band (CB) radio?” One of the younger guys in the group asked “What is CB radio?” Whoa! I guess I forgot how old a technology this is. It certainly is not as visible as it used to be. In any case, I had to explain that CB radio is a two-way radio communications system sanctioned by the Federal Communications Commission (FCC) that does not require a license. Anyone can use it if you buy the licensed and approved equipment. In case you didn’t know, CB radio is still around. If you haven’t tried it, you just might find it fits one of your communications needs.

CB BACKGROUND

The FCC established a personal communications service back in the late 1940s. Most of the frequency assignments were in the 450 MHz UHF range and it never became popular. In 1958 and in the 1960s, the 27 MHz spectrum was assigned to the newly created Class D radio service. This is what has become known as CB radio. The 27 MHz spectrum (also known as 11 meters) was initially divided into 23 fixed frequency channels. Early transceivers used tubes and had to use two crystals for each channel: one for the transmitter and another for the receiver’s local oscillator. Crystals were expensive back then, so many of the lower priced units only covered a few channels.

The 1960s brought about the solid-state movement, so CB radios quickly adopted transistor circuitry making them smaller, less expensive, and easily battery operated. Phase-locked loop (PLL) frequency synthesizers came along making it possible to synthesize all channels from one or two crystals. Later, the FCC opened up more channels, making a total of 40 available. These are the channels used today (see **Table 1**).

Incidentally, while all channels are used, some are

much more popular and useful than others. Channel 9 is an emergency calling frequency. It is not used for regular conversation, but instead is used only when someone needs help. Some police and highway patrol units monitor it on a regular basis. Channel 19 has become a general calling frequency for anyone wanting to establish a

Channel	Frequency (MHz)	Channel	Frequency (MHz)
1	26.965	21	27.215
2	26.975	22	27.225
3	26.985	23	27.255
4	27.005	24	27.235
5	27.015	25	27.245
6	27.025	26	27.265
7	27.035	27	27.275
8	27.055	28	27.285
9	27.065	29	27.295
10	27.075	30	27.305
11	27.085	31	27.315
12	27.105	32	27.325
13	27.115	33	27.335
14	27.125	34	27.345
15	27.135	35	27.355
16	27.155	36	27.365
17	27.165	37	27.375
18	27.175	38	27.385
19	27.185	39	27.395
20	27.205	40	27.405

Table 1

connection. Usually, those who link up switch to another clear channel.

CB radio really became popular in the 1970s. It was initially adopted by long distance truckers who wanted to know about gasoline sources, speed traps, heavy traffic, accidents, and the like. Back then, there was a gasoline shortage and a 55 MPH highway speed limit that drove the truckers nuts. CB radio really made it easier for all of them. Many other people put CBs in their cars and connected with the truckers on long highway trips.

CB radio became a major hobby. It was for those who wanted to be amateur radio operators but didn't want to learn the code or electronics to pass the FCC exams. The FCC issued licenses and call signs back then, but dropped both after it could not keep pace with the millions that wanted them. The license requirement and call signs were dropped. That led CB operators to adopt a name or "handle" that could identify them and present a radio personality.

CB was also popularized by many movies and songs back in the 1970s. Movies like *Smokey and the Bandit*, TV shows like *Dukes of Hazzard*, and songs like *Convoy* made CB a real phenomenon. And don't forget all the colorful expressions like "good buddy," "breaker, breaker," plus the 10 codes like 10-4 (received clearly) and 10-20 (location) were extremely popular.

The CB frenzy eventually faded, but it still continued to be popular. Over the years as new technology has come along, CB has now become a secondary communication choice, if it is known at all. There are so many other communications options today, CB has become an anachronism.

CB TECH

CB radios come in two basic form factors: mobile units for under-dash mounting and handheld units. **Figure 1** shows some typical units. The mobile units take their power from the car battery, while the handhelds have an internal rechargeable battery. The mobile units rely on a rather large (six to 10 feet) whip antenna, whereas the handhelds have their own telescoping whip or "rubber ducky" antenna. Some companies still make a basestation unit with a built-in AC power supply.

■ **FIGURE 1.** Cobra Electronics Corporation (www.cobra.com) was one of the earlier suppliers of CB radios, and they are still in the business. Some of their popular products are the HH38WXST handheld which includes a weather radio and their 29 NW LTC Classic mobile unit. Check your local retailers to buy.



The basic transmission mode is plain old amplitude modulation (AM). A more sophisticated version uses single sideband (SSB) — a form of AM that uses only one sideband to conserve spectrum space. Maximum output power to the antenna is limited to four watts for AM and 12 watts peak envelope power (PEP) for SSB. The receivers are superheterodynes and all 40 channels are frequency synthesized. Prices run from about \$50 to \$150 for a typical unit, making CB one of the most affordable forms of two-way radio for personal or business use.

As for radio wave propagation, the 11 meter band has some unusual characteristics. It is only good for a one to five mile range in local coverage. However, frequencies in the 27 MHz range use sky waves to communicate over huge distances. Such waves go up to the ionosphere — an ionized region miles above the earth, where they are refracted or bent back to earth many miles away. Such propagation permits worldwide communications even with low power. This makes coast to coast communications possible, not to mention contacts with CB operators in other countries that use those frequencies. However, be forewarned. The FCC Part 95 rules do not permit contacts beyond 155 miles.

THE FRS ALTERNATIVE TO CB

FRS means Family Radio Service — another personal communications service created by the FCC. It uses the 460 MHz UHF spectrum and (like CB) specific channel frequencies are assigned (see **Table 2**).

Channels 8 through 14 are strictly for FRS use, but Channels 1 through 7 are shared with the General Mobile

Channel Number	Frequency (MHz)
1	462.5625
2	462.5875
3	462.6125
4	462.6375
5	462.6625
6	462.6875
7	462.7125
8	467.5625
9	467.5875
10	467.6125
11	467.6375
12	467.6625
13	467.6875
14	467.7125

Table 2

Radio Service (GMRS) — a licensed service available to business.

Virtually all FRS radios are handhelds that are battery powered. FRS radios use frequency modulation (FM), so have better noise immunity and fidelity than CB. The transmit power is restricted to 0.5 watts. Furthermore, the antenna must be affixed to the unit. The low power and antenna restrictions limit practical range to less than a mile. With a clear line-of-sight path, several miles are possible. Mountain tops and high buildings make good platforms for long range communications. UHF

signal propagation is LOS and any path blockage by walls, buildings, trees, cars, or whatever severely limits range. The units are best used for short distances indoors or out.

The FRS radios serve a different purpose than CB radios. They are great for just keeping in touch in close situations. Car to car, shopping centers, stadiums, parks, and other large areas make it possible for people to stay in contact. Boating is another use.

You can get a pair of FRS transceiver handhelds for less than \$50 at RadioShack and other electronic dealers.

THE DECLINE OF TWO-WAY RADIO

I just recently got out my RadioShack CB handheld and recharged it. I tried listening on all the channels and got little for my effort. I heard a few weak signals on Channel 11 but nothing on Channel 19. I suspect my small rubber ducky antenna is part of the problem. A longer, higher outdoor antenna would bring in more traffic, I think. The band was essentially deserted. But then again, that is a good thing as it is open for business. Most CB units (like my handheld) have a VHF weather radio built in. I was able to hear the local weather station loud and clear. Check your local RadioShack for both CB and FRS radios.

While CB and FRS radios are still used, their presence is not as great as it once was. Bet you can guess why — cell phones. Pretty much everyone carries one these days and they basically cover our personal communications needs. However, every now and then, a two-way radio makes sense so keep it in mind when you need to communicate. And remember, CB can still be a hobby of sorts. The good thing about these services is that the equipment is cheap and available to play around with. So go ahead and give them a try, good buddies. 10-4. **NV**



The Lynxmotion Servo Erector Set

Imagine it... Build it... Control it!

With our popular Servo Erector Set you can easily build and control the robot of your dreams. Our interchangeable aluminum brackets make the ultimate precision mechanical assemblies. Our Visual Sequencer for SSC-32 provides powerful PC, Atom, or BS2 based control.

Visit our huge website to see our complete line of aluminum and Lexan based robot kits, electronics, and mechanical components.



Biped BRATs



Round 3DOF Hex



Mini 2DOF Hex



Johnny 5



A4WD1



AL5C Arm



Bipeds

www.lynxmotion.com
Toll Free: 866-512-1024

Images represent a fraction of what can be made! The SES now has 143 unique components!

ELECTRONET

Now available in the Nuts & Volts webstore, the 16-Bit Experimenter Handbook CD-ROM.

By Tom Kibalo



200 Pages of detailed explanations.
41 Fully illustrated experiments in 'C' code.

\$69.95
Subscriber Discount Available!

For more information and kits, please visit:
www.nutsvolts.com

www.canakit.com

- Over 200 Kits & Modules to choose from!
- Easy Worldwide Online Ordering
- Fast Delivery & Same Day Shipping

FM Transmitters • Timers • Audio Amplifiers • Motor Controllers



Microcontroller Boards
GREAT for Breadboards, Home Projects, Experiments, Test Fixtures, Prototypes, Labs and more. Microcontrollers, Communications, Display, Power.

BASIC ON BOARD Eliminates development tools

ATRIA Technologies Inc
www.AtriaTechnologies.com



IMAGES Scientific Instruments

SCIENCE, ROBOTICS & ELECTRONICS

Microcontrollers
Servo Control & Motors
Artificial Vision
Speech Recognition

www.imagesco.com
Tel: (800) 230-4535 Fax: (718) 966-3695



Sheet Metal Fabrication

Complete Fabrication Center
Integrated Ideas & Technologies, Inc.
Precision Laser, Waterjet, Plasma, Machining, Forming, and Welding Capabilities
www.iitmetalfab.com



USB Add USB to your next project-- It's easier than you might think!

USB-FIFO • USB-UART • USB/Microcontroller Boards
RFID Readers • Design/Manufacturing Services Available
Absolutely NO driver software development required!

www.dlpdesign.com



Serial LCD & LED
www.melabs.com



Pololu
Robotics & Electronics
WWW.POLOLU.COM



THE ORIGINAL SINCE 1994
PCB-POOL
Beta LAYOUT

- Low Cost PCB prototypes
- Free laser SMT stencil with all Proto orders

WWW.PCB-POOL.COM

MINDS-i

What can YOU build?

mymindsi.com



ramsey
www.ramseykits.com
AM/FM Broadcasters • Hobby Kits
Learning Kits • Test Equipment
...AND LOTS OF NEAT STUFF!



INVEST in your BOT!

INVEST in **HITEC**

12115 Paine Street • Poway, CA 92064 • 858-748-6948 • www.hiteccrd.com



ALL ELECTRONICS
CORPORATION
Electronic Parts & Supplies
Since 1967



For the ElectroNet online, go to
www.nutsvolts.com
click **Electro-Net**



#39 SMILEY'S WORKSHOP

C PROGRAMMING - HARDWARE - PROJECTS

by Joe Pardue

Digital I/O — Part 1



Recap

Last month, we continued looking at tools to put in our avrtoolbox and added the C Standard Library, paying special attention to the venerable `printf()` functions. We finished by developing a command-line interpreter tool. This month, we are going to dive into digital I/O (Input/Output). I've checked the depth, so you probably won't hit your head on any rocks.

Ports?

If you ever wondered why a group of pins on a microcontroller might be called a port, you need look no

farther than **Figure 1** — a Google Map of Port Saplaya, Spain. The sea can be a wild and dangerous place where ships batten down and fight their way through storms until they get to the safety of a port. In a port, the waves are broken and the ship is safely tied to a dock where goods can be moved (ported) to and from warehouses and highways.

A microcontroller port is analogous to a seaport in that the pins of a port buffer the sensitive inner workings of the microcontroller from the chaotic outer world, allowing you to safely move digital data to and from the processor core. In practice, we apply the term port to several different kinds of input and output: We have various serial ports such as the USART or SPI, and we

have the topic of this month's Workshop: digital I/O ports, which are arrays of eight pins considered as a unit.

Why eight pins? This is because the ports are peripherals that are viewed by the AVR processor core as being memory locations, and the AVR addresses memory as locations for eight bits of data. The AVR core knows nothing about the electrical vagaries of the outside world, leaving the conditioning electronics to sort that out. The core just sees a port as a memory location that it can read data from or write data to.

Pins?

The Arduino folks made a radical (okay, that's my opinion) decision to ignore the port concept and present the novice with pins as individually numbered entities independent of any other pin. That is a great simplification for the novice, and maybe that isn't even so radical since

■ FIGURE 1. Google Map of Port Saplaya, Spain.



the AVR does guarantee that you can change and use any pin of a port without affecting any other pin on that port.

So, let's go with this idea of pins as separate entities and ignore ports for a moment, and present a pin-based Arduino-like elementary digitalio library for our avrtoolbox. This library is written for the ATmega328 (which I tested on an Arduino board) and the AVR Butterfly which uses the ATmega169.

Avrtoolbox Digitalio Library

The avrtoolbox digitalio library – like most of our elementary libraries – looks a lot like something from the Arduino. This is intentional and provides a transition for the novice Arduino user to progress to using the more professional AVR C programming resources: AVRStudio, WinAVR, avrlibc, avr-gcc, etc. Once you decide you are ready to move beyond the Arduino, you have the elementary avrtoolbox libraries and associated source code to let you see how this is done in C (okay, you get to see how I think it ought to be done in C). Don't get me wrong. I love the Arduino and use it all the time, even in 'professional' projects, but it was never intended to be a full-fledged development environment, so I'm trying to provide the tools that will help make the transition easier.

Digitalio Functional Requirements Specification

Digitalio Initialization Function: Allows the user to set a pin as either input or output, with the option of using the output pull-up resistor or not.

Digitalio Input Function: Allows the user to read the digital state of an input pin.

Digitalio Output Function: Allows the user to set the digital state of an output pin.

Digitalio Application Programmer's Interface pin_mode() – Digitalio Initialization Function

Description: Sets the specified pin to either input or output.

Syntax: void pin_mode(uint8_t pin, uint8_t mode)

Parameters:

Pin: Pin to set the mode for.

Mode: Either INPUT or OUTPUT.

Returns: Nothing.

Example: pin_mode(9, OUTPUT);

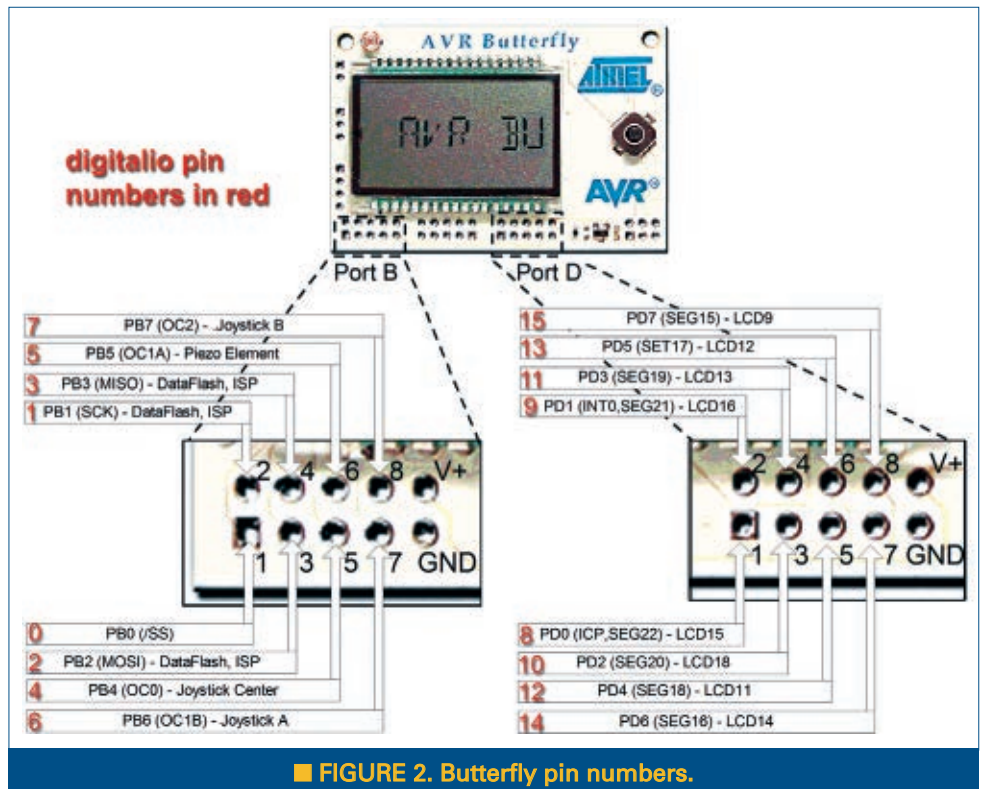

■ FIGURE 2. Butterfly pin numbers.

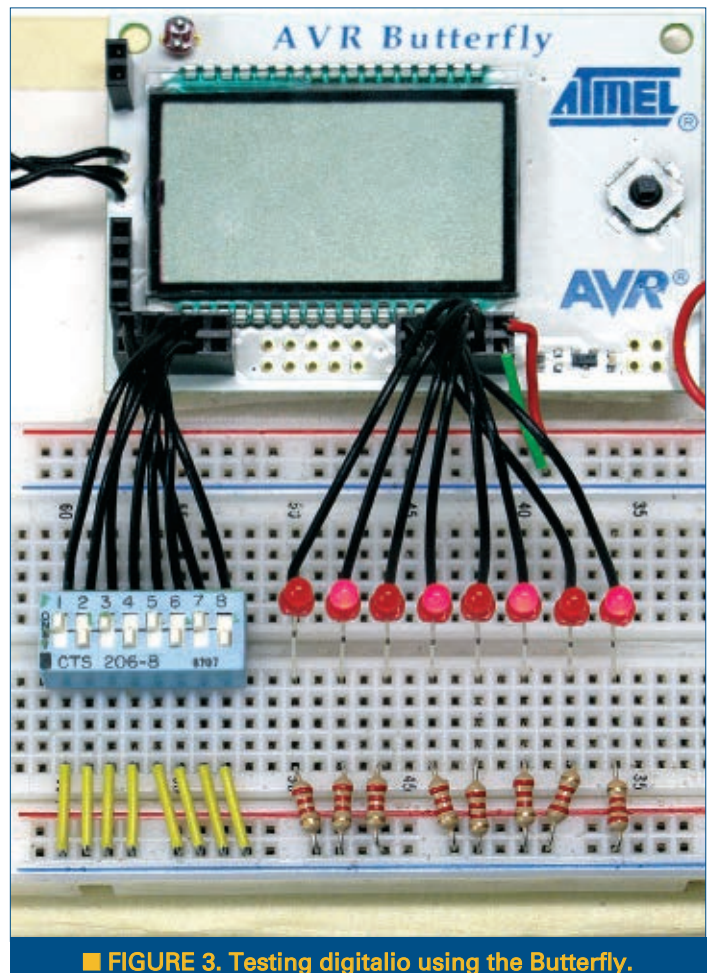

■ FIGURE 3. Testing digitalio using the Butterfly.

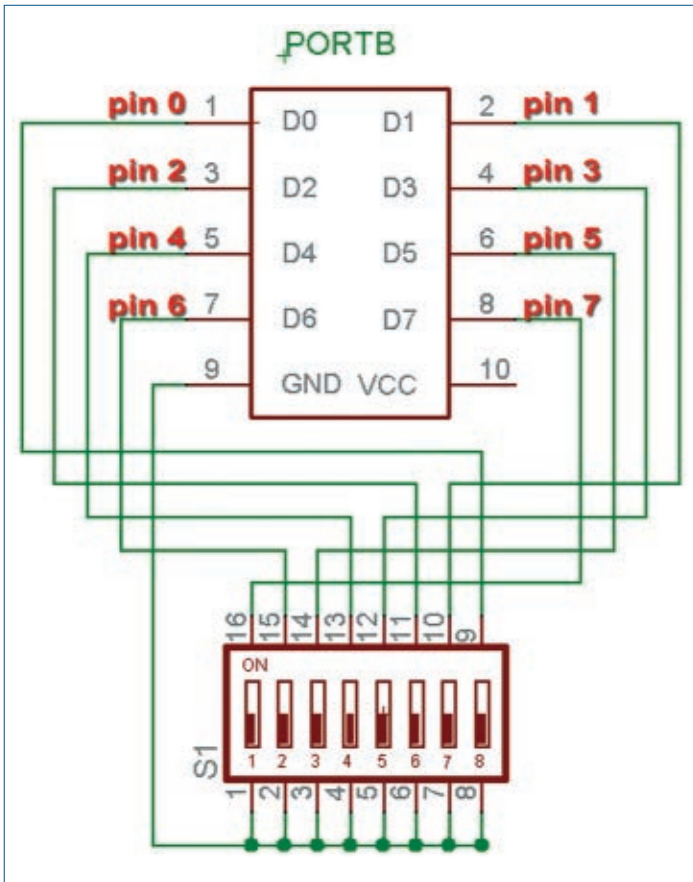

■ FIGURE 4. Schematic for DIP switch to Butterfly pins 0 through 15.

digital_read() – Digitalio Input Function

Description: Reads the state of the indicated input pin.

Syntax: int digital_read(uint8_t pin)

Parameters: Pin: The number of the pin to read.

Returns: HIGH, LOW, or ERROR.

Example:

```
// wait until the monkey pushes the
// button then give him some candy
while(digital_read(8) == HIGH); // wait forever for the
button push
digital_write(9,HIGH); // open the candy door
```

digital_write() – Digitalio Output Function

Description: Sets the state of the indicated output pin.

Syntax: void digital_write(uint8_t pin, uint8_t value)

Parameters:

Pin: Pin to set either HIGH or LOW.

Value: HIGH or LOW.

Returns: Nothing.

Example:

```
if(digital_read(8) == LOW) // did somebody trip the
door sensor?
{
    digital_write(7) = HIGH; // if so, turn on the lights
}
```

The Source Code

This code is written for both the Butterfly and the Arduino board using AVRStudio (not the Arduino IDE). If you aren't already familiar with how to do this, you may want to refer to earlier Workshops to review how to compile and upload the code.

The tester is very simple and merely reads the DIP switch and shows the state on the LEDs. Once you build the hardware for this and get it all working, be sure and save it for next month where we will do some more complex things using the same setup.

Using the Digitalio Library With the Butterfly

Since this about input and output, let's dig out that eight-bit DIP switch and use it to set the states on eight LEDs. In Figure 2, you see the Butterfly pins for ports B and D shown

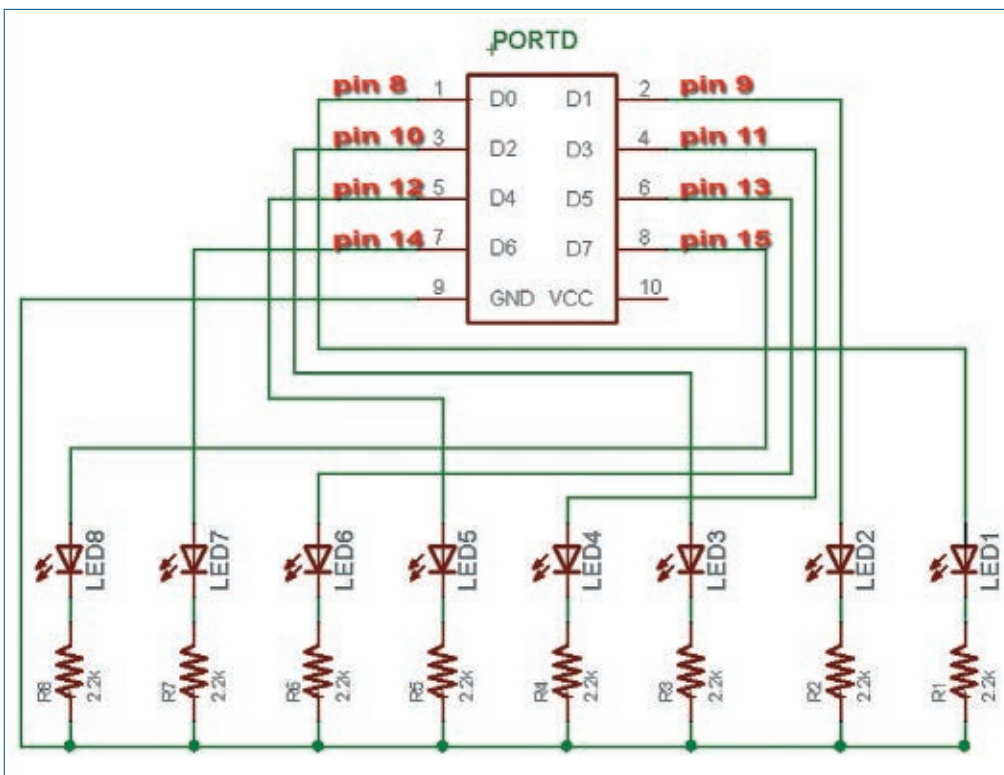

■ FIGURE 5. Schematic for LEDs to Butterfly pins 8 through 15.

as pin numbers to use with the digitalio library. The test program — as usual — is located in the testers directory at <http://code.google.com/p/avrtoolbox/libavr>. The functions are in the /source/elementary/digitalio directory and the tester is in the /testers directory. Rather than use a precompiled object library in digital_c_tester_butterfly, I include the source for the digitalio library functions since these functions are small.

Using the Digitalio Library With the Arduino

Our work is simplified for the Arduino since it already has the pin numbers labeled on the board as shown in **Figure 5** and **6** (if they look vaguely familiar, it is because we used this circuit in Workshop 12). The tester program — like for the Butterfly — is also located in the testers directory at <http://code.google.com/p/avrtoolbox> and is named digitalio_c_tester_atmega328. Remember that this is AVRStudio base code and even though we are using the Arduino hardware, we are not using the Arduino IDE.

Digital I/O Electrical Characteristics

After getting our toes wet with some elementary software, let's go off the high board and look at the hardware. Microcontroller ports (like real ports) are limited in how much protection they can provide and like a seaport, when a hurricane comes along the port can get swamped. In the good old days, you were advised to wear static protection when messing with ICs to prevent static electricity from entering the pin and zapping something important inside the chip. Nowadays, devices like the AVR have input diodes (**Figure 8**) that help protect them.

The first thing to note is the diodes connecting the pin to Vcc and GND. These help protect the pin from things like you walking across a wool carpet on a dry winter's day and then gently touching your micro — 'snap!' — exposing it to a few thousand volts of static electricity. There is also an input capacitance associated with the pin that you might have to deal with in your circuit design, though it is small and I usually ignore it. Also, there is a pull-up resistor that we can activate to connect the pin to VCC through about 20K ohms — more on this later.

Figure 9 shows more detail.

We know that for something to be digital in our microcontroller binary logic sense it can have two states that can be thought of as true and false, high and low, 1 and 0. From the simplicity of these two states flows the

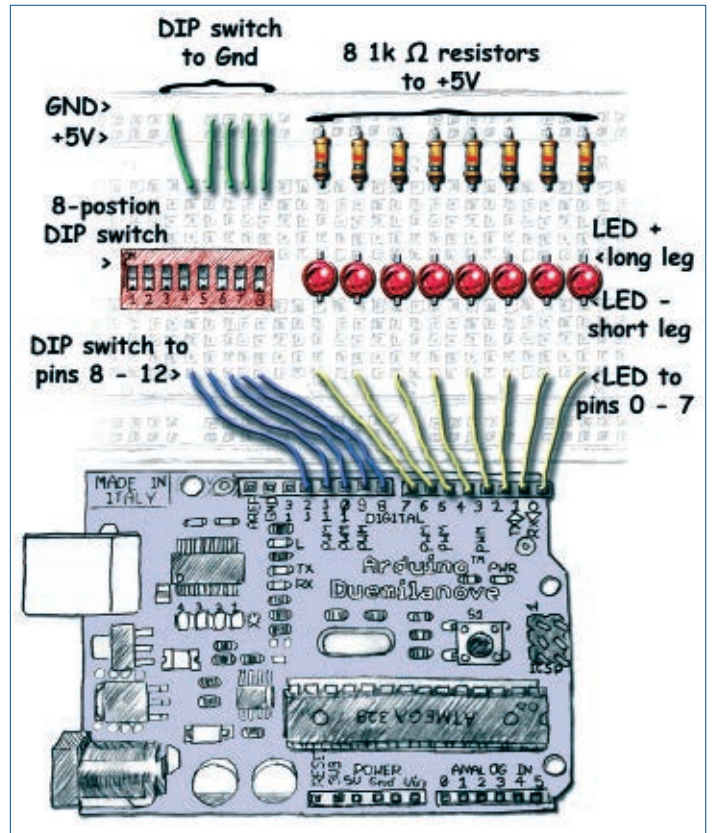

■ **FIGURE 6.** Testing digitalio using the Arduino.

entire digital revolution — arguably the most significant change in human history — so it is kind of fun to be able to actually get our hands on these magical 'states' in the form of little silver pins hanging on the sides of our AVR black box. We use digital input when we want to sense an event in the real world such as a button state. We use digital output when we want to change something in the real world such as lighting an LED. [And that is pretty much all we do with microcontrollers: We sense and change things.]

■ **FIGURE 7.** Arduino pins for DIP switch and LEDs.

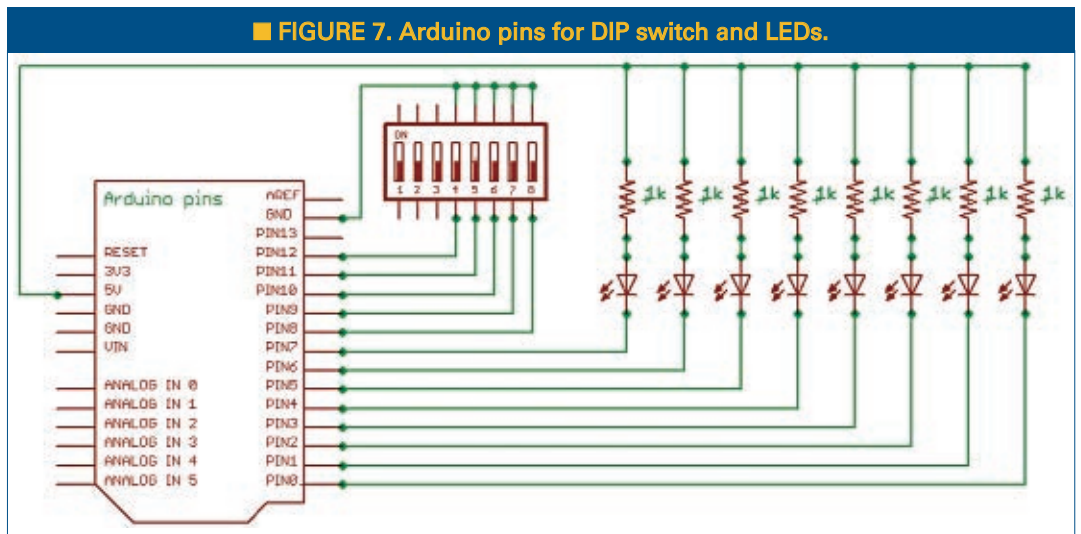

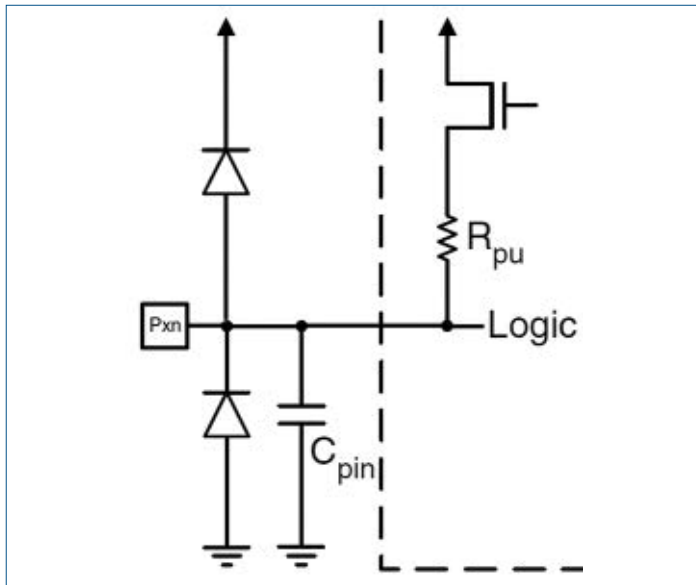

■ FIGURE 8. Pin equivalent circuit.

even if the pin immediately rises to 2.1 or 2.9999. It has to go all the way to three to change the pin to high; then if it drops below three, the pin continues to indicate high until it falls below two volts when it changes to low. This is called hysteresis and is a great feature because it allows us to measure signals with some noise on them.

Imagine a signal that is slowly dropping from three to two, but has a bit of ± 0.2 volts high frequency chaos jumping around. If the pin state changes from high to low and low to high at exactly two volts, then you'd see the pin toggling like crazy, going off and on due to the noise while the real signal (the average of all that noise) we are interested in takes its own good time falling below our threshold plus the noise level. We might read a thousand transitions while the signal voltage falls the extra 0.2 volts noise needed to get completely below the transition threshold.

Logic Input/Output Voltage Levels

Hysteresis?

In our case, this refers to the concept that we must have above a certain voltage to generate a 1, and below a different lower voltage to generate a 0. For a five volt AVR, we considered any voltage above three volts to be 1, high, or true, and any voltage below two volts to be 0, low, or false. What about voltages between two and three?

If a voltage falls below two, then the pin indicates low

In the discussion above, I said that for 5V a value above three was a 1 and below two was 0; that was a simplification to help understand the concept. Looking at the ATmega328 datasheet section 29.8.9 *Pin Threshold and Hysteresis*, we see that for the I/O pin to read 1 when the Vcc is five volts, the input voltage level should be above about 2.6 volts. For the pin to indicate 0 with a Vcc of five volts, then the input voltage should be below about 2.1 volts. So, using five volts we have a hysteresis of about 0.5 volts. At a Vcc of 3.3V, these values would be above about 1.6 volts for a 1 and below about 1.25 for a 0, with about 0.35 volts hysteresis.

Why do I keep saying 'about?' That is so you won't memorize these figures and think you know how to generate a 1 or 0 on an input pin. Ask yourself: When have you ever gotten exactly five or 3.3 volts for Vcc? What if you are using batteries and you've got 3.2 volts one day and 2.7 a month later? What I'm saying is that you need to consider these thresholds and hysteresis values as ballpark figures for your application. Make sure you've got some extra voltage if you want to be certain you've got a 1, and that you take it down farther than the indicated low to assure that you are getting a 0.

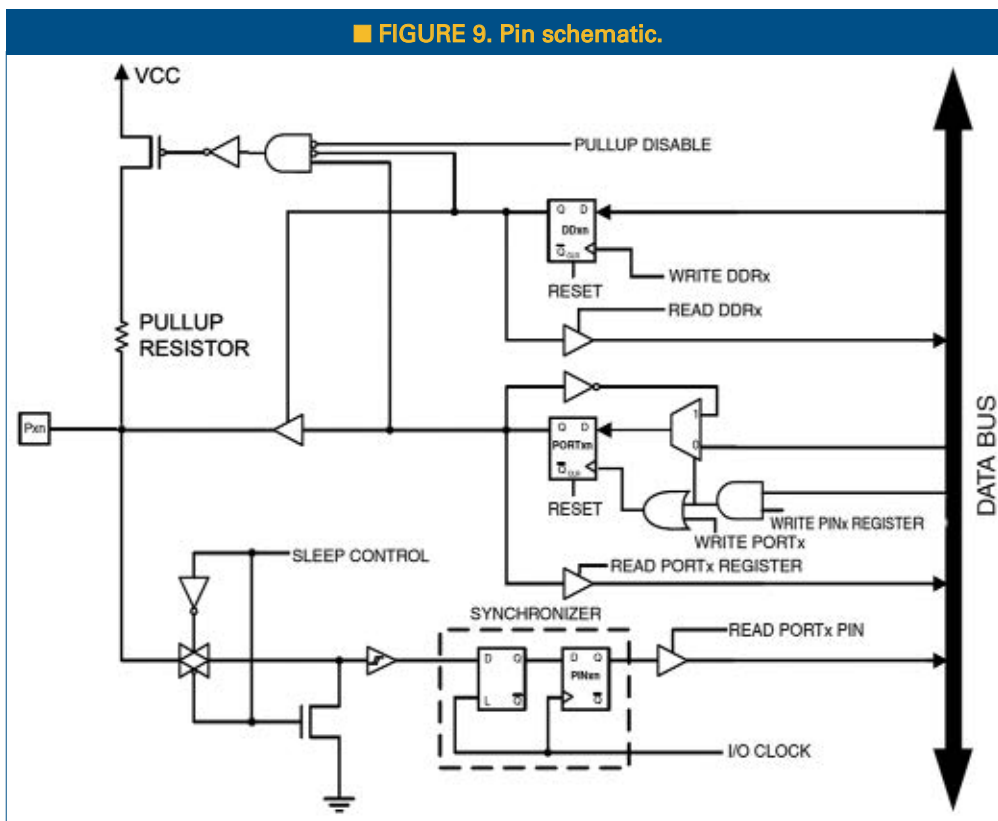

■ FIGURE 9. Pin schematic.

The Arduino website [<http://arduino.cc/en/Reference/Constants>] states that for a digital input high you need to provide greater than 3V, and for a digital input low you need to provide less than 2V. While this is certainly true for the standard 5V Arduino, it isn't true for those Arduinos that use lower voltages such as the 3.3V models. For these, the 3V high will work, but for the low you really need to provide less than 1V. You might think that this would be simple, but look no further than the thread I started on AVRfreaks to see that it isn't: <http://tinyurl.com/3r6aoyu>.

If you look at the datasheet section 28.2 DC Characteristics, you get some absolute maximum and minimum electrical parameters to work with. The datasheet Table 28-1 shows the maximum input low:

- For Vcc = 1.8V–2.4V maximum input low is 0.2*Vcc.
 - For Vcc = 2.4–5.5V maximum input low is 0.3*Vcc.
- Minimum input high:
- For Vcc = 1.8V–2.4V minimum input high is 0.7*Vcc.
 - For Vcc = 2.4 – 5.5V minimum input high is 0.6*Vcc.

From which we can calculate:

- For 1.8 volts, the maximum input low is 0.2*1.8V = 0.65V.
- For 1.8 volts, the minimum input high is 0.7*1.8V = 1.26V.
- For 5.5 volts, the maximum input low is 0.3*5V = 1.65V.
- For 5.5 volts, the minimum input high is 0.6*5V = 3.3V.

Okay, this is getting to be way too much so let's promulgate a rule of thumb that applies in all cases: **take 0.2*Vcc for low and 0.7*Vcc for high.** If this is too restrictive and you want to make the reasonable assumption that your five volt system won't fall below 2.4 volts, then you can use a narrower range of 0.3 Vcc and 0.6 Vcc which for five volts gives you above 0.6*5 = 3V for a high, and below 0.3*5 = 1.5V for a low.

What about digital output? Well, that is a bit clearer but with the complication that it depends on the current it has to provide to the output circuit.

- Output low for 5V at -20 ma is 0.9V or less.
- Output low for 3V at -10 ma is 0.6V or less.
- Output high for 5V at -20 ma is 4.2V or more.

- Output high for 3V at -10 ma is 2.3V or more.

We can see that these digital output high and low values will work with the digital input pins, but if you are using them to drive something other than an AVR compatible digital input, then you might have to take a look at the datasheet.

Questions?

As usual, if you want to be helpful when you find a problem or have a question, you'll need to put on your biohazard suit and start a thread on www.avrfreaks.net with the word 'avrtoolbox' in the title and I probably will see it. Read my blog entry that will tell you why you need the biohazard suit first at <http://smileymicros.com/blog/2011/01/24/using-an-internet-forum>. Next month, we are going to take a deeper look at digital input and output, confronting the datasheet, examining the registers, and learning how to do digital I/O in ordinary C.

If you just can't wait and want to get a leg up on all this serial stuff and real C programming for the AVR (while helping support your favorite magazine and technical writer), then buy my C Programming book and Butterfly projects kit and/or the Arduino Workshop book and projects kit from the *Nuts & Volts* web shop. **NV**



\$149^{.95}

USB-LOGIC
USB Logic Analyzer

New

Canakit™
www.canakit.com



\$99^{.95}

DSO-NANO-V2
Pocket-Sized Digital Oscilloscope



\$59^{.95}

ARDUINO-STK
Arduino Uno Starter Kit

\$59^{.95}

ASSEMBLED



UK1104
4-Port USB Relay Controller with 6-Channel Analog/Digital Interface

FM Transmitters • Timers • Audio Amplifiers • Motor Controllers • Custom Designs

www.canakit.com

1-888-540-KITS (5487)

CLASSIFIEDS

KITS/PLANS

QKITS.COM



Qkits Ltd

50 AMP PWM

1-888-GO 4 KITS

SAM-III Geomagnetometer Kit

- 3-Axis - N-S, E-W, Vertical
- ±50,000 nT, 1-2 nT resolution
- 12 Vdc
- Complete kit includes software
- Logging with PC or standalone
- Join worldwide magnetometer network
- Starting at US\$199.95

www.reeve.com/SAM3.htm

Looking for solar stuff to read about and build? Then check out **Nuts & Volts!**

www.nutsvolts.com

HARDWARE WANTED

DEC EQUIPMENT WANTED!!!

Digital Equipment Corp. and compatibles.
Buy - Sell - Trade

CALL KEYWAYS 937-847-2300
or email buyer@keyways.com

OSCILLOSCOPES

Bargain 25MHz Scope

This low-cost 2-channel OWON scope is packed with useful features normally only seen on higher-end DSOs including video triggering, auto-measurements, large 8" full color LCD display, 500MS/s, XY Mode, auto-set, averaging, FFT, USB output, waveform storage, and 3 year warranty!

Visit www.saelig.com for more details. **Only \$287**

Saelig.com follow us:  

unique electronics

High Quality Electronic Kits & Modules



\$59.95
UK1133

50 AMP DIGITAL PWM (OPTIONAL DISPLAY)

FM Transmitters
Timers
Audio Amplifiers
Motor Controllers
PIC Programmers / Arduino

... Custom Designs ...

www.canakit.com

Electronic Kits

- Fun and Educational
- Discount White and Blue LEDs
- Quantity Discounts



www.bakatronics.com

JOB OPENINGS

Electronics company seeking part-time account representatives, sales payment and bookkeepers. Applicants must be computer literate with access to the Internet, Send resume to: moore1719@gmail.com

ENERGY SOLUTIONS

Save Money On Your Electric Bill

www.sunny-solutions-shop.com

800-315-0309

SURPLUS

SURPLUS ELECTRONIC PARTS & ACCESSORIES

	Over 18,000 Items in Stock.	Cables Connectors Displays Fans	Hardware LEDs Motors Potentiometers	Relays Semiconductors Service Manuals Speakers	Switches Test Equipment Tools VCR Parts
	Surplus Material Components SMC ELECTRONICS www.smcelectronics.com		No Minimum Order. Credit Cards and PAYPAL Accepted. Flat \$4.95 per order USA Shipping.		

COMPONENTS

RF PARTS™ CO.

Tubes, Transistors, Power Components

Email: rpf@rfparts.com • Web: www.rfparts.com

800-737-2787 Fax 888-744-1943

uM-FPU V3.1
Floating Point Coprocessor



32-bit IEEE 754 SPI or I2C DIP-18, SOIC-18

Extensive floating point support, GPS input, FFT, 12-bit A/D, matrix operations, user-defined functions.

Next month...new 64-bit product!

www.micromegacorp.com

LEDs

Super Brights from 20¢
RGB Color Mixing 30 Pack \$6.99
Assortment 120 Pack \$24.99
Shipping from \$3.00

Alan-Parekh.com/Store

The Nuts & Volts Pocket Ref



Only \$12.95

Thomas J. Glover

NUTS & VOLTS
EVERYTHING FOR ELECTRONICS
www.nutsandvolts.com

All the info you need at your fingertips!

This great little book is a concise all-purpose reference featuring hundreds of tables, maps, formulas, constants & conversions. AND it still fits in your shirt pocket!

Visit <http://store.nutsvolts.com> or call (800) 783-4624

DESIGN/ENG SERVICES

- * Circuit board layouts
- * Prototype assemblies

WWW.OSPREYELECTRONICS.COM

Convert your sketch or print into a quality pcb for a reasonable price. Visit us on the web or call Osprey Electronics at (208) 664 1089 (USA)

ROBOTICS

MaxSonar
Ultrasonic Ranging is EZ



LV-MaxSonar-EZ

- Power-up calibration
- Smallest MaxSonar
- Low power, 2.5V-5.5V
- \$29.95 USD qty. 1



MaxSonar-WR (IP67)

- Industrial packaging
- Weather resistant
- Standard ¼" fitting
- \$99.95 USD qty. 1



XL-MaxSonar-EZ

- Beam pattern choice
- Real-time calibration
- High acoustic power
- \$39.95 USD qty. 1



MaxSonar-WRC (IP67)

- Compact packaging
- Weather resistant
- Quality narrow beam
- \$99.95 USD qty. 1

www.maxbotix.com

Looking for robot stuff and kits?

www.servomagazine.com

The Nuts & Volts **WEBSTORE**

ELECTRONICS

15 Dangerously Mad Projects for the Evil Genius

by Simon Monk

NEW!

UNLEASH YOUR INNER MAD SCIENTIST!

This wickedly inventive guide explains how to design and build 15 fiendishly fun electronics projects. Filled with photos and illustrations, *15 Dangerously Mad Projects for the Evil Genius* includes step-by-step directions, as well as a construction primer for those who are new to electronics projects.

\$24.95

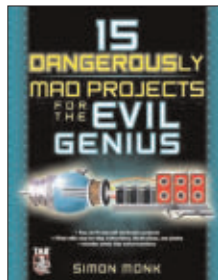

Master and Command C for PIC MCUs

by Fred Eady

Master and Command C for PIC MCU, Volume 1 aims to help readers get the most out of the Custom Computer Services (CCS) C compiler for PIC microcontrollers. The author describes some basic compiler operations that will help programmers — particularly those new to the craft — create solid code that lends itself to easy debugging and testing. As Eady notes in his preface, a single built-in CCS compiler call (output_bit) can serve as a basic aid to let programmers know about the "health" of their PIC code.

\$14.95



How to Diagnose and Fix Everything Electronic

by Michael Jay Geier

Master the Art of Electronics Repair!

In this hands-on guide, a lifelong electronics repair guru shares his tested techniques and invaluable insights.

How to Diagnose and Fix Everything Electronic shows you how to repair and extend the life of all kinds of solid-state devices, from modern digital gadgetry to cherished analog products of yesteryear.

About the Author

Michael Jay Geier began operating a neighborhood electronics repair service at age eight that was profiled in *The Miami News*.

\$24.95



tinyAVR Microcontroller Projects for the Evil Genius

by Dhananjay Gadre and Nehul Malhotra

Using easy-to-find components and equipment, this hands-on guide helps you build a solid foundation in electronics and embedded programming while accomplishing useful — and slightly twisted — projects. Most of the projects have fascinating visual appeal in the form of large LED-based displays, and others feature a voice playback mechanism. Full source code and circuit files for each project are available for download.

\$24.95



Build Your Own Electronics Workshop

by Thomas Petruzzellis

BUILD YOUR OWN DREAM ELECTRONICS LAB!

This value-packed resource provides everything needed to put together a fully functioning home electronics workshop! From finding space to stocking it with components to putting the shop into action -- building, testing, and troubleshooting systems. This great book has it all! And the best part is, it shows you how to build many pieces of equipment yourself and save money, big time!

Reg Price \$29.95
Sale Price \$24.95



Electronics Explained

by Louis Frenzel

The New Systems Approach to Learning Electronics

Don't spend time reading about theory, components, and old ham radios - that's history! Industry veteran, Louis Frenzel, gives you the real scoop on electronic product fundamentals as they are today. Rather than tearing electronics apart and looking at every little piece, the author takes a systems-level view. For example, you will not learn how to make a circuit but how a signal flows from one integrated circuit (IC) to the next, and so on to the ultimate goal.

\$29.95

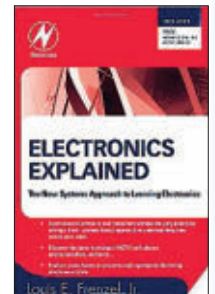

Making Things Move: DIY Mechanisms for Inventors, Hobbyists, and Artists

by Dustyn Roberts

In *Making Things Move: DIY Mechanisms for Inventors, Hobbyists, and Artists*, you'll learn how to successfully build moving mechanisms through non-technical explanations, examples, and do-it-yourself projects — from kinetic art installations to creative toys to energy-harvesting devices. Photographs, illustrations, screenshots, and images of 3D models are included for each project.

\$29.95



TEARDOWNS

by Bryan Bergeron

Learn How Electronics Work by Taking Them Apart

Amp up your knowledge of electronics by deconstructing common devices and analyzing the revealed components and circuitry. *Teardowns: Learn How Electronics Work by Taking Them Apart* contains 14 projects that expose the inner workings of household appliances, workbench measuring instruments, and musical equipment. Discover how resistors, capacitors, sensors, transducers, and transistors function in real circuitry.

Reg \$24.95 **Sale Price \$21.95**



PICAXE Microcontroller Projects for the Evil Genius

by Ron Hackett

This wickedly inventive guide shows you how to program, build, and debug a variety of PICAXE microcontroller projects. *PICAXE Microcontroller Projects for the Evil Genius* gets you started with programming and I/O interfacing right away, and then shows you how to develop a master processor circuit.

\$24.95



Order online @ www.nutsvolts.com
 Or CALL 1-800-783-4624 today!

BOOK & KIT COMBOS

Beginner's Guide Complete Combo!

Combo Price **\$229.95**
 VOL 3 Experiment Component Pack

For complete details, visit our webstore @ www.nutsvolts.com.

16-Bit Complete Combo

Combo Price **\$319.95**

For complete details visit our webstore @ www.nutsvolts.com

Puzzled by the Arduino?

Based on *Nuts & Volts Smiley's Workshop*, this combo gives you all the pieces you need!

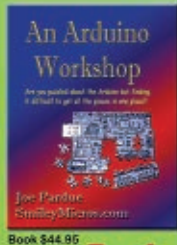

Book and Kit Combo \$124.95

CD-ROM SPECIALS

Nuts & Volts 7 CD-ROMs & Hat Special!

That's 84 issues.
 Complete with supporting code and media files.

Free Shipping!

Only \$149.95
 or \$24.95 each.

Published monthly by T & L Publications, Inc. www.nutsvolts.com

The Learning Lab

Reg Price \$79.95

Subscriber's Price \$75.95

This lab — from the good people at GSS Tech Ed — will show you 40 of the most simple and interesting experiments and lessons you have ever seen on a solderless circuit board. As you do each experiment, you learn how basic components work in a circuit. Along with the purchase of the lab, you will receive a special password to access the fantastic online interactive software to help you fully understand all the electronic principles. For a complete product description and sample software, please visit our webstore.

POCKET REF

Only \$19.95!

NUTS & VOLTS
 EVERYTHING FOR ELECTRONICS
www.nutsvolts.com

This great little book is a concise all-purpose reference featuring hundreds of tables, maps, formulas, constants, and conversions. AND it still fits in your shirt pocket!

CALL 1-800-783-4624 today!
Or Order online @ www.nutsvolts.com

PROJECTS

32-Bit Micro Experimenter Board

The new 32-Bit Micro Experimenter is the fastest way to learn 32-bit microcontrollers.

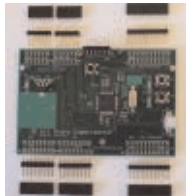

The kit includes onboard 46 programmable I/O and USB, free software, carefully documented step-by-step experiments for USB, embedded web server, graphics and audio, wireless, RTOS, and file I/O. User pushbuttons, LEDs, and 32 kHz clock crystal. Can be used in solderless breadboard environment or stand-alone.

Also supports Arduino compatible interface.

Subscriber's Price **\$89.95**
 Non-Subscriber's Price **\$93.95**

Piezoelectric Film Speaker Kit

As seen in the November 2010 issue, here is a great project to amaze your friends and to demonstrate a unique way of producing sound. Kit contains one piece of piezoelectric film, speaker film stand, PCB, components, audio input cable, and construction manual. All you'll need to add is a battery and a sound source. For more info, please visit our website.

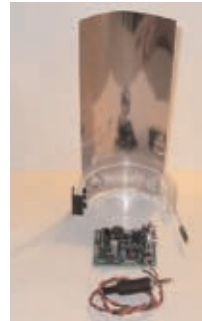

Subscriber's Price **\$69.95**
 Non-Subscriber's Price **\$74.95**

CHIPINO Kit

The CHIPINO module is an electronic prototyping platform that is used in a series of articles starting with the March 2011 issue of *Nuts & Volts Magazine*.



Assembled units \$29.95!

Developed by the CHIPAXE Team as a bridge between PICs and Arduinos. The module was designed specifically to match the board outline, mounting holes, connector spacing, and most of the microcontroller I/O functions found on the popular Arduino module.

Subscriber's Price **\$18.95**
 Non-Subscriber's Price **\$19.95**

Magic Box Kit

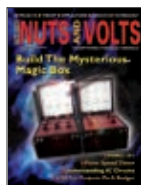

As seen in the April 2007 cover

This unique DIY construction project blends electronics technology with carefully planned handcraftsmanship. This clever trick has the observer remove one of six pawns while you are out of the room and upon re-entering you indicate the missing pawn without ever opening the box.

Includes an article reprint.

Subscriber's Price **\$39.95**
 Non-Subscriber's Price **\$45.95**

Mini-Bench Supply Complete Kit



A small power supply with +5V, +12V, and -12V outputs is a handy thing to have around when you're breadboarding circuits with both op-amps and digital ICs.

Kit includes: Enclosure box, accessories, DC-to-DC converter kit, switching regulator kit, and article reprint. For more information, please see the "feature article section" on the of the *Nuts & Volts* website.

Subscriber's Price **\$76.95**
 Non-Subscriber's Price **\$83.95**

Sorting Counter Kit NEW!



As seen in the July 2011 issue.



Sorting counters have many uses — keeping score, counting parts, counting people — it is just a handy gadget to have around. This is a very simple project for those who want to learn to solder or are interested in using microprocessors and how they function. No special tools are needed, just a small tip soldering iron. It has no box as it stands alone, therefore there is no drilling.

Subscriber's Price **\$33.95**
 Non-Subscriber's Price **\$39.95**

16-Bit Experimenter Handbook



From the series of articles by Tom Kibalo, *The Complete 16-Bit Experimenter Handbook on CD-ROM!*

NEW!

This CD-ROM handbook contains: 200 pages of detailed instructions and 41 experiments with 'C' software examples. Also includes the experiments for the dsPIC33.

For a complete list of kits and combos, please visit our webstore.

Subscriber's Price **\$64.95**
 Non-Subscriber's Price **\$69.95**

Transistor Clock Kit



If you like electronic puzzles, then this kit is for you! There are no integrated circuits; all functionality is achieved using discrete transistor-diode logic. The PCB is 10"x11" and harbors more than 1,250 components! For more info, see the November 2009 issue.

Sale!

Reg **\$225.95**
 Sale Price **\$199.95**

PCBs can be bought separately.

The Amateur Scientist 4.0 The Complete Collection

by Bright Science, LLC

There are 1,000 projects on this CD, not to mention the additional technical info and bonus features. It doesn't matter if you're a complete novice looking to do their first science fair project or a super tech-head gadget freak; there are enough projects on the single CD-ROM to keep you and 50 of your friends busy for a lifetime!

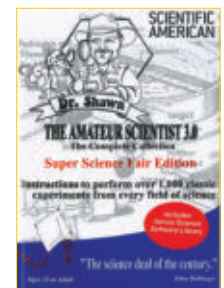

Reg **\$26.95** Sale Price **\$23.95**

Send all questions and answers by email to forum@nutsvolts.com
Check at www.nutsvolts.com for tips and info on submitting to the forum.

All questions AND answers are submitted by *Nuts & Volts* readers and are intended to promote the exchange of ideas and provide assistance for solving technical problems. Questions are subject to editing and will be published on a space available basis if deemed suitable by the publisher. Answers are submitted by

readers and **NO GUARANTEES WHATSOEVER** are made by the publisher. The implementation of any answer printed in this column may require varying degrees of technical experience and should only be attempted by qualified individuals. *Always use common sense and good judgment!*

>>> QUESTIONS

Blinking LED

Could someone come up with a simple schematic for a blinking LED (clear but blinks red)? The item would use an NTE5405 SCR, a high intensity (MSD) LED, and an LSR (light sensitive resistor), all driven by a nine volt battery. The purpose would be for the blinking light to remain out during the day but would come on at night and blink about once every seven seconds. It would then go out during the daytime.

#10111

Cy Fedor
via email

PIC16F690

What is the easiest or best way to PWM a PIC16F690? I've seen Chuck Hellebuyck's book, but he uses an external pot to manually do it. I need to do it in software.

#10112

Resonance
Baraboo, WI

Basic Compiler

What cheap or free Basic compilers are being used for programming PICs?

#10113

Gregg Reber
via email

>>> Comments

I just received my September issue and looked at the proposed solution to problem 7113. The solution proposed is quite simple and the analysis of its operation is correct. However, its output is not linear with the value of Rx — as is indicated by the formulas. I believe the request was for a linear response. I have not built the circuit in **Figure 1**, but it looks like it should do what was requested by Brian. U1 must be a rail-to-rail, single supply quad op-amp. A TS914 should work; +V should be between ≈12 and +15V.

U1.1 is a current source which I have used and found in a *Linear*

Applications handbook by National Semiconductor. It ensures that the voltage across Rx is linear.

U1.2 is a comparator. Its output is high when the voltage across Rx is below the voltage set by VR1, and is low (ground) when the voltage across Rx is higher than the voltage set by VR1.

U1.3 will act as a follower with gain when the output of U1.2 is at ground. When the output of U1.2 is high, the output of U1.3 will be at ground.

U1.4 acts as an inverter since Brian wanted +10V when the resistance is low.

The +10V can be derived from a zener diode or a 10V reference IC.

Variable gain to set the voltage for the desired maximum resistance value for the circuit can be derived by varying any of several resistors. I would suggest making R8 a 5K potentiometer. Without knowing the actual resistances Brian wants to measure, I cannot suggest values for R1-R5. However, the voltage across Rx should be kept to < 5V due to the operation of U1.3 which has a minimum gain of one. If desired, an LED with series limiting resistor can be added to the output of U1.2. If the LED circuit is

connected to ground, it will indicate when Rx is below the threshold set by VR1. If it is connected to V+, it will indicate when Rx is above the VR1 threshold and is in the linear range of the circuit.

Larry Cicchinelli - K3PTO
via email

>>> ANSWERS

[#8111 - August 2011]

Backup Alarm

I would like to install a backup alarm on my '07 Mazda Miata with the Mazda jingle (ZOOM ZOOM). I can get the jingle from YouTube but I don't know if it's possible to erase the sounds on a current backup alarm and install the jingle, or build an entirely new alarm.

Get a programmable greeting card at a pharmacy or Walmart, replace the battery with a three volt power supply, and connect the output to a suitable audio amp.

Russell Kincaid
Milford, NH

[#8113 - August 2011]

Analog S Meter

I have a vintage Realistic DX-400 shortwave radio. The signal meter finally

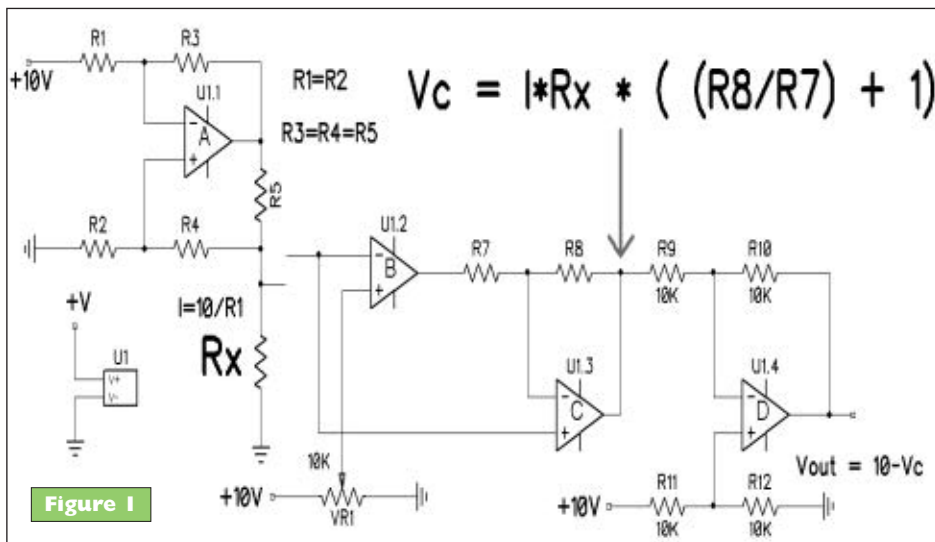

gave out after all these years. I would like a small circuit to fit in a small confined space, using a 10 bargraph LED. The bargraph should fit perfect in the small window where the needle meter once was.

The LM3914 is made for that application. The datasheet will have a schematic; all you need to do is determine the maximum voltage that is applied to the S meter.

Russell Kincaid
Milford, NH

**[#9111 - September 2011]
Voltage Problem?**

We would like to plug our credit card terminal into one of our Vodavi Starplus STSe telephone system's SLT ports so that we can use the system's "off-hook preference" feature to find an unused line. However, the credit card terminal needs more power than the 22V provided by the KSU's single line port which drops to 8V when in use. Sometimes the terminal says "no line" and other times it does connect but something inside the terminal is causing a clicking noise – although it does send the DTMF dialing signals in spite of the clicking. We have tried our fax machine on the same KSU port and it works very well. I have tried simply adding a 9V battery in series and it solved the original problem 100% – no clicking, no "no line" message, and the KSU found an unused line just fine. However, the phone company no longer was able to recognize the DTMF dialing.

#1 Being a telecom installer and although I have never worked with the Vodavi STSe, we install credit card machines all the time on IST ports on Comdial and Vertical, and program them for auto group line selection.

Yes, the IST only provides 24 VDC, but does provide about 40 ma loop current. A standard line is 51 VDC on-hook and at 35 ma current, will give you about 6 VDC off-hook. Those off-hook voltages will vary greatly depending on how far you are from the office. Out here where I am

(very rural area), I have seen off-hook as low as 3 VDC.

I really am thinking that there is something adrift with your terminal. The terminal should work fine on a 24 VDC on-hook circuit. The voltage is not normally the key; it is the amount of loop current available. Also, it helps to put a P (pause) ahead of the number being dialed. Sometimes when the switch sees off-hook and selects the line, there could be a very short delay. The switch has not yet selected the line when the terminal has already started to dial, hence it will miss sending the first digit or two to the CO.

R. Kauffman
Beavertown, PA

#2 I have been in the interconnect business a long time and I know that the voltage from the phone system cannot be increased. It is fixed by specially designed chips, made specifically for the manufacturer of the system. The reason the fax works is it does NOT rely on the line for power. If your credit card machine has an auxiliary power input, that should make it work like the fax.

Dennis Hewett
Frontenac, KS

**[#9113 - September 2011]
Increase Resolution**

How do I increase the resolution of a variable resistor (pot)? I have to move the knob so slightly that I can't fine-tune or properly adjust the resistance in the circuit.

There are numerous possible ways to increase the resolution of the potentiometer. Which ones are preferable depends on the external conditions and limitations which are not addressed in the question.

The simplest way is to replace the ordinary potentiometer with a multi-turn potentiometer. If the potentiometer needs to be adjusted often, then this would require a fairly large and relatively expensive unit. If, however, the usage is a "set it and forget it" application, then a "trimmer" potentiometer would be appropriate; then the size and cost would be comparable to an ordinary potentiometer.

Another approach is to divide the potentiometer operation between "coarse" and "fine" potentiometers. Again, several approaches present themselves, depending on whether it's only the resistance that needs to be controlled or if there is a voltage that

The Standard for checking Capacitors in-circuit



Good enough to be the choice of Panasonic, Pioneer, NBC, ABC, Ford, JVC, NASA and thousands of independent service technicians.

Inexpensive enough to pay for itself in just one day's repairs. At \$229, it's affordable.

And with a 60 day trial period, satisfaction guaranteed or money-back policy, the only thing you can lose is all the time you're currently spending on trying to repair all those dogs you've given up on.

CapAnalyzer 88A

Available at your distributor, or call 561-487-6103

Electronic Design Specialists

Locate shorted or leaky components or conditions to the exact spot in-circuit

Still cutting up the pcb, and unsoldering every part trying to guess at where the short is?

\$229



Your DVM shows the same shorted reading all along the pcb trace. LeakSeeker 82B has the resolution to find the defective component. Touch pads along the trace, and LeakSeeker beeps highest in pitch at the defect's pad. Now you can locate a shorted part only a quarter of an inch away from a good part. Short can be from 0 to 150 ohms.

LeakSeeker 82B

www.eds-inc.com

needs to be controlled.

If resistance needs to be controlled, then the circuitry needed is very simple. It is only necessary to wire the two controls in series, with the fine control potentiometer having roughly 1/10 the resistance of the coarse control potentiometer. In this case, the potentiometer should be adjusted by first setting the fine control potentiometer to zero resistance, set the coarse control to have a resistance slightly less than is desired, then finally use the fine control to set the total resistance to the value desired.

If the voltage needs to be controlled, then the two potentiometers need to be wired together in a slightly more complicated circuit. **Figure 2** illustrates one way this can be accomplished. The fine control potentiometer should be enough lower in resistance than the coarse control potentiometer to give the desired amount of expansion; again, a 10-to-1 ratio would seem reasonable. This

configuration is relatively simple but has some disadvantages. First, the total resistance of the combination changes drastically as the coarse control is adjusted. Secondly, as the coarse control is adjusted toward higher settings, the amount of expansion provided by the fine control is reduced. For these reasons, this configuration is practical only if the coarse control is used for the bottom of the range.

A configuration that is free of the disadvantages of the circuit of **Figure 2** is shown in **Figure 3**. This circuit requires two "ganged" potentiometers for the coarse control, i.e., two potentiometers that are adjusted simultaneously with a single knob. Here again, a 10-to-1 ratio of the resistances of the coarse and fine potentiometers would seem to provide a reasonable amount of expansion. The total resistance across the circuit would be very roughly equal to the sum of the resistances of

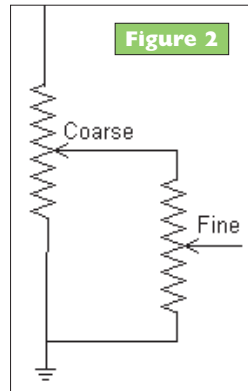

Figure 2

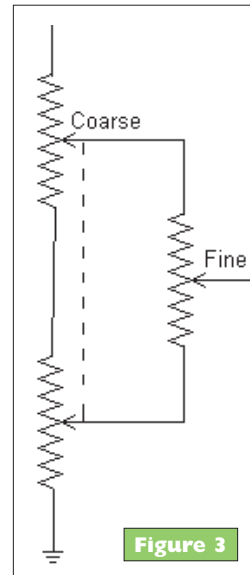

Figure 3

the fine potentiometer and one of the coarse potentiometers, depending on the ratio of their resistances. On the other hand, that total resistance would be fairly constant, depending on how well the two ganged potentiometers track each other.

Howard Mark Sufern, NY

AMATEUR RADIO AND TV

Ramsey Electronics, Inc.20-21
V-Module26

BATTERIES/CHARGERS

Cunard Associates27

BUYING ELECTRONIC SURPLUS

Jaycar Electronics49
Weirdstuff Warehouse27

CCD CAMERAS/VIDEO

Circuit Specialists, Inc.82-83
Ramsey Electronics, Inc.20-21

CIRCUIT BOARDS

AP Circuits48
Cunard Associates27
Dimension Engineering41
ExpressPCB29
Front Panel Express LLC11
PCB Pool62
V-Module26

COMPONENTS

Anaren35
Cana Kit Corp.73
Fun Gizmos27
Noritake48
SDP/SI27
superbrightleds.com41
V-Module26

COMPUTER

Hardware
Noritake48
Weirdstuff Warehouse27

Microcontrollers / I/O Boards

Abacom Technologies26
Bitscope4
Chipino27
Fun Gizmos27
PI Controls63
microEngineering Labs47
MikroElektronika3
Parallax, Inc.Back Cover
Pololu Robotics & Electronics5
Solarbotics/HVW9

DESIGN/ENGINEERING/REPAIR SERVICES

Cana Kit Corp.73
ExpressPCB29
Front Panel Express LLC11
PCB Pool62

DRIVE COMPONENT CATALOGS

SDP/SI27

EDUCATION

BaneBots9
Bitscope4
Blue Wolf19
Command Productions19
Global Specialties19
NKC Electronics27
PAIA27
Poscope61

EMBEDDED TOOLS

PI Controls63
NetBurner2

ENCLOSURES

Front Panel Express LLC11
Integrated Ideas & Tech.55

KITS & PLANS

Cana Kit Corp.73
Jaycar Electronics49
NetBurner2
NKC Electronics27
PAIA27
QKITS13
Ramsey Electronics, Inc.20-21
Solarbotics/HVW9

MISC./SURPLUS

All Electronics Corp.81
Front Panel Express LLC11
Weirdstuff Warehouse27

MOTORS

BaneBots9

OPTICS

Noritake48

PROGRAMMERS

microEngineering Labs47
MikroElektronika3

PROTOTYPING & TRAINERS

Global Specialties7

RF TRANSMITTERS/RECEIVERS

Abacom Technologies26
Anaren35
Blue Wolf19
Twin Peaks Robotics27

ROBOTICS

BaneBots9
Blue Wolf19
Fun Gizmos27
Lemos International Co., Inc.8
Lynxmotion, Inc.66
Pololu Robotics & Electronics5
SDP/SI27
Solarbotics/HVW9
Twin Peaks Robotics27

SATELLITE

Lemos International Co., Inc.8

TEST EQUIPMENT

Bitscope4
Circuit Specialists, Inc.82-83
Dimension Engineering41
Electronic Design Specialists79
Global Specialties7
HAPRO Electronics13
Jaycar Electronics49
NKC Electronics27
Poscope61

TOOLS

MikroElektronika3
NetBurner2
PanaVise48

WIRELESS PRODUCTS

Anaren35
Twin Peaks Robotics27

Abacom Technologies26
All Electronics Corp.81
Anaren35
AP Circuits48
BaneBots9
Bitscope4
Blue Wolf19
Cana Kit Corp.73
Chipino27
Circuit Specialists, Inc.82-83
Command Productions19
Cunard Associates27
Dimension Engineering41
Electronic Design Specialists79
ExpressPCB29
Front Panel Express LLC11
Fun Gizmos27
Global Specialties7
HAPRO Electronics13
PI Controls63
Integrated Ideas & Tech.55
Jaycar Electronics49
Lemos International Co., Inc.8
Lynxmotion, Inc.66
microEngineering Labs47
MikroElektronika3
NetBurner2
NKC Electronics27
Noritake48
PAIA27
PanaVise48
Parallax, Inc.Back Cover
PCB Pool62
Pololu Robotics & Electronics5
Poscope61
QKITS13
Ramsey Electronics, Inc.20-21
SDP/SI27
Solarbotics/HVW9
superbrightleds.com41
Twin Peaks Robotics27
V-Module26
Weirdstuff Warehouse27

ALL ELECTRONICS

C O R P O R A T I O N

QUALITY Parts
FAST Shipping
DISCOUNT Pricing

CALL, WRITE, FAX or E-MAIL
for a FREE 96 page catalog.
Outside the U.S.A. send \$3.00 postage.

12VDC 1A POWER SUPPLY

Switching power supply.
Input: 100-240V, 50-60Hz, 0.3A.
Output: 12Vdc, 1Amp.
Right-angle coax power plug.
5.5mm od, 2.1mm id, center
positive. cULus, CE.

CAT# PS-1219 **\$8.95**
each



MINI-PANCAKE VIBRATING MOTOR

LG Innotek Co.# TA09-T3001459AA / Spec MVMF-A346T3. 10mm dia. x 3mm thick. Operates on 1.5 - 4 Vdc. Two 12mm wire leads. Prepped with adhesive patch on one side.

CAT# DCM-707 **\$1.00**
each



50 for 80¢ each • 100 for 75¢ each

MINI-STEREO AUDIO AMPLIFIER W/ SPEAKERS

Miniature 4W (2 x 2W) stereo amplifier with speakers and battery holder.

3.5mm stereo phone plug input connects to many portable audio sources, MP3s, iPods etc. The on-off switch and volume control are in a 34mm square module attached to the amplifier with a 29" flat cable. The speakers included with the amp are an interesting pair of 1.30" x 1.45" x 0.36" flat-panel speakers incorporating a unique cone-less technology. We don't know for what application these speakers are intended; they might be better for voice or sound effects, but the amplifier sounds a lot better with traditional 4 Ohm cone-type speakers. Operates on 4 AA batteries, not included.

CAT# AMP-5 **\$8.50**
each

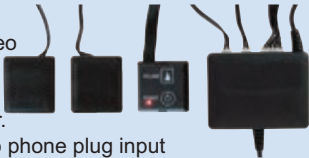

ROTARY ENCODER

30 detents. 11.5 x 13.5 x 8mm body. 7mm diameter x 10mm long plain bushing. 6mm diameter split knurled shaft. PC leads. Two support tabs on 10mm centers.

CAT# REC-3 **75¢**
each



40 CHARACTER X 2 LINE LCD W/ LED BACKLIGHT

#UMSH-3077JD-YG. STN Transflective LCD. Yellow-green LED backlight. Module size: 182 x 33.5 x 13.6mm. Viewing area: 154.4 x 16.5mm. Character size: 3.2 x 5.55mm.

CAT# LCD-3077 **\$8.50**
each

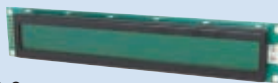

10 for \$7.50 each

PRECISION DC GEAR MOTOR, USED

FAULHABER #1624E024SNP305. Small, powerful-for-its-size, very-low current, Swiss made gear motor. No-load Ratings: 320 RPM @ 12Vdc/ 2.5mA. 545 RPM @ 20Vdc / 3.9mA. 17mm diameter x 40mm long overall. 2mm diameter x 10mm shaft with attached 11.7mm diameter pulley for round, 2mm belt. Motor face has 4 tapped mounting holes. Two wire leads, 45mm. Used, removed from equipment in good condition.

CAT# DCM-705 **\$8.85**
each



21MM PIEZO ELEMENT

50mm wire leads. CAT# PE-56

\$1.00
each



10 for 85¢ each

12 VDC FLASH ASSEMBLY

Bright xenon strobe assembly with horseshoe flash tube. Approximately 80 flashes per minute. 65 x 75mm PC board. 12 Vdc operation.

CAT# FSH-13 **\$7.00**
each



20 X 2 LINE VACUUM FLUORESCENT DISPLAY



NEC #FCX20X2JA-AB. Overall size: 161.0 x 34 x 22mm. Blue-green display. High-brightness 5mm high, 5 x 7 dot characters. Modules include driver and micro-controller ICs with refresh RAM, character generator and interface logic. High speed 8 bit parallel interface is 5V CMOS compatible, suitable for connection to a host CPU bus.

CAT# VF-202 **\$8.50**
each

3 1/2 DIGIT LCD MULTI-METER W/ BACKLIGHT

Velleman # DVM850BL. For features, accuracy and ruggedness, this is the best inexpensive multimeter we've ever seen. DC current (10 A), DC and AC voltage (600 V), resistance (2 M ohm), diode, transistor tester, audible continuity and hold button. Protective rubber shell and test leads included.

CAT# DVM-850BL **\$17.95**
each



BREADBOARD, 840 CONTACTS

Breadboards accommodate all sizes of dips and discrete components. Interconnect with solid hook-up wire (#22 AWG recommended). Wires and components can be used and re-used many times without damage to board or components. Dual row of buss terminals on each side of terminal strip.

CAT# PB-840



\$7.65
each

Shop ON-LINE www.allelectronics.com
ORDER TOLL FREE 1-800-826-5432

MAIL ORDERS TO:
ALL ELECTRONICS CORP.
14928 OXNARD ST., VAN NUYS, CA 91411-2610

FAX (818) 781-2653 • INFO (818) 904-0524
E-MAIL allcorp@allcorp.com

NO MINIMUM ORDER • All Orders Can Be Charged to Visa, Mastercard, American Express or Discover • Checks and Money Orders Accepted by Mail • Orders Delivered in the State of California must include California State Sales Tax • NO C.O.D • Shipping and Handling \$7.00 for the 48 Continental United States - ALL OTHERS including Alaska, Hawaii, P.R. and Canada Must Pay Full Shipping • Quantities Limited • Prices Subject to change without notice.

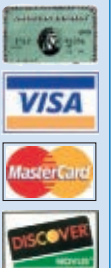

MANUFACTURERS - We Purchase EXCESS INVENTORIES... Call, Write, E-MAIL or Fax YOUR LIST.



Programmable DC Electronic Load 0~80V / 0~40A

NEW



The 3721A Programmable DC Electronic Load provides excellent performance with sophisticated features found on much more expensive units. This 400 watt, 40 Amp, 0~80 volt Programmable DC Electric Load can be used to test all sorts of DC power sources including power supplies and is especially helpful to battery manufacturing processes. This DC load features constant voltage, constant resistance, constant current and constant power settings. The end user can design programs that control precisely all of the load values and time durations for each step of a test sequence. Up to nine 10 step programs can be internally stored in the 3721A Programmable DC Load.

4 basic functions: CC, CV, CR & CP

8 basic test modes: CCL, CCH, CV, CRL, CRM, CRH, CPV & CPC

Minimum operating voltage is less than 0.6v at the load's full rated current.

High-speed sequence, high-speed transient, short circuit, battery discharge and other functions.

Programmable current slew rate.

Multiple groups of parameters and lists can be saved & recalled.

Supports SCPI and LabView with included software.

Current Rating: 0~40A

Voltage Rating: 0~80V

Power Rating: 400W at 40°C

Item#

CSI3721A

\$720.00

www.CircuitSpecialists.com/CSI3721A

Programmable DC Electronic Loads



These devices can be used with supplies up to 360VDC and 30A. It features a rotary selection switch and a numeric keypad used to input the maximum voltage, current and power settings. These electronic DC loads are perfect for use in laboratory environments and schools, or for testing DC power supplies or high-capacity batteries. It also features memory, and can also be connected to a PC, to implement remote control and supervision.

360V/150W (CSI3710A) \$349.00

www.circuitspecialists.com/csi3710a

360V/300W (CSI3711A) \$499.00

www.circuitspecialists.com/csi3711a

Your Hot Air Rework Headquarters

Surface-Mount components have taken over from through-hole components in many electronic products produced today. Circuit Specialists, Inc stocks numerous Hot Air Rework solutions to handle this trend.

Our many rework solutions offer a wide range of nozzle designs and many have built-in holders for efficient placement of the air stream for proper application of heat/airflow over the desired component.

www.circuitspecialists.com/hot-air-rework



BlackJack SolderWerks
Hot Air System
with Suction Pen
& Mechanical Arm.

BK4050
\$119.00

www.circuitspecialists.com/bk4050



BlackJack SolderWerks
Hot Air Rework Station
with Digital Display, Mechanical
Arm & 70w Soldering Iron.

BK5050
\$169.00

www.circuitspecialists.com/bk5050



BlackJack SolderWerks
Deluxe Rework System with
Hot Air, Soldering Iron, Suction
Gun & Mechanical Arm.

BK6000
\$229.00

www.circuitspecialists.com/bk6000



CircuitSpecialists.com
Compact Rework Center with
Hot Air Gun and Soldering Iron.

CSI899A+
\$99.00

www.circuitspecialists.com/csi899a+



CircuitSpecialists.com
ESD Safe, CPU Controlled,
SMD Hot Air Rework Station
with Hot Air Gun & Suction.

CSI825A
\$99.00

www.circuitspecialists.com/csi825a



CircuitSpecialists.com
ESD Safe SMD Rework Station
with Hot Air Gun
& Soldering Iron.

CSI906
\$99.00

www.circuitspecialists.com/csi906



CircuitSpecialists.com
Hot Air Gun w/Digital Display for
Surface Mount Devices.

CSIHOTGUN-2
\$89.00

www.circuitspecialists.com/csihotgun-2

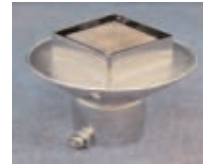

CircuitSpecialists carries a large
selection of Nozzles for BGC,
PLCC, QFP, SOP and single
point applications.

www.circuitspecialists.com/hot-air-nozzles

60 Watt Digital Soldering Station

For use with traditional or Lead Free Soldering



Features:

- * 60 watt dual core ceramic heater
- * 150 to 450 degree Celsius Temperature range
- * Versatile easy to read liquid crystal display
- * 3 preset & user definable temperature settings.
- * Automatically remembers previous temperature setting
- * Display in Celsius or Fahrenheit scale
- * 3 foot cord length from station to iron tip
- * Broad selection of replacement tips available

Item#

CSI-Station-3DLF

\$49.00

www.CircuitSpecialists.com/CSI-Station-3DLF

Circuit Specialists carries a wide selection of traditional & lead-free soldering equipment, including soldering irons, soldering stations, hot-air rework stations, focused infrared systems, reflow ovens, pre-heating systems, regular and lead-free solder, solder flux, and soldering aids for both thru-hole and surface-mount soldering.

See our complete line of soldering equipment at:

www.CircuitSpecialists.com/soldering-equipment





We carry a LARGE selection of Power Supplies, Soldering Equipment, Test Equipment, Oscilloscopes, Digital Multimeters, Electronic Components, Metal and Plastic Project Boxes, Electronic Chemicals, PC Based Digital I/O Cards, Panel Meters, Breadboards, Device Programmers, and many other interesting items. Check out our website at:
www.CircuitSpecialists.com

Best Value, Low Cost Station CSI-Station1A



Easily our best value in our selection of soldering stations. O.E.M. manufactured just for Circuit Specialists Inc., so we can offer the best price possible! The CSI-Station1A features a grounded tip & barrel for soldering static-sensitive devices and uses a ceramic heating element for fast heat up & stable temperature control.

The control knob is calibrated in Fahrenheit & Celsius (392° to 896°F and 200° to 480°C). One of the nicest features is the high quality comfort grip soldering iron. The iron connects to the station via an easy screw-on connector making iron replacement a snap. The 1 meter length iron cord provides plenty of length for users to set up the station in a convenient location. Another nice feature is the soldering iron holder. Made of rugged aluminum, it is a separate piece from the main station & allows the user maximum convenience.....you don't have to reach all the way back to the station to store the iron. Yet another feature is the stackable design of the CSI-Station1. The main station is designed for an additional unit to be placed on top of it allowing for space saving placement of the CSI-Station1A. Also included at no additional charge is one user replaceable ceramic heating element so that you will be prepared! Large selection of soldering tips available too.

Item# **CSI-STATION1A** **\$29.95**

www.circuitspecialists.com/csi-station1a

3 Channel Programmable Regulated DC Power Supplies



Check out our new programmable hi performance 3 channel power supplies. Featuring both USB & RS232 interfaces, Overload Protection, Auto Fan Control, and Series or Parallel Operation. Both units feature a Large LCD display panel with simultaneous output and parameter view and a keypad for control. They are ideal for applications requiring high resolution, multiple output, and automated operation such as in production testing. There are both fine and coarse controls via the shuttle knob and 90 memory settings. Software included.

CSIPPS33T 0~32V / 0~3A **\$299.00**

www.CircuitSpecialists.com/CSIPPS33T

CSIPPS55T 0~32V / 0~5A **\$379.00**

www.CircuitSpecialists.com/CSIPPS55T

200MHz Hand Held Scopemeter with Oscilloscope & DMM Functions

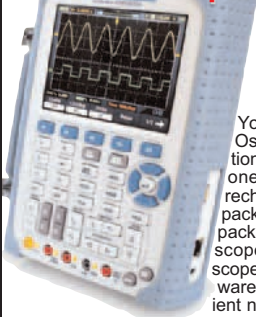

Includes
1 Year USA
Warranty

You get both a 200 MHz Oscilloscope and a multi function digital multimeter, all in one convenient lightweight rechargeable battery powered package. This power packed package comes complete with scopemeter, test leads, two scope probes, charger, PC software, USB cable and a convenient nylon carrying case.

- 200MHz Handheld Digital Scopemeter with integrated Digital Multimeter Support
- 200MHz Bandwidth with 2 Channels
- 500MSa/s Real-Time Sampling Rate
- 50Gsa/s Equivalent-Time Sampling Rate
- 6,000-Count DMM resolution with AC/DC at 600V/800V, 10A
- Large 5.7 inch TFT Color LCD Display
- USB Host/Device 2.0 full-speed interface connectivity
- Multi Language Support
- Battery Power Operation (Installed)

Item# **DSO1200** New Low Price! **\$589.00**

www.circuitspecialists.com/DSO1200

60MHz Hand Held Scopemeter with Oscilloscope & DMM Functions

- 60MHz Handheld Digital Scopemeter with integrated Digital Multimeter Support
- 60MHz Bandwidth with 2 Channels
- 150MSa/s Real-Time Sampling Rate
- 50Gsa/s Equivalent-Time Sampling Rate
- 6,000-Count DMM resolution with AC/DC at 600V/800V, 10A
- Large 5.7 inch TFT Color LCD Display
- USB Host/Device 2.0 full-speed interface connectivity
- Multi Language Support
- Battery Power Operation (Installed)

Item# **DSO1060** New Low Price! **\$429.00**

www.circuitspecialists.com/DSO1200

60MHz Hand Held Scopemeter w/Oscilloscope, DMM Functions & 25 MHz Arbitrary Waveform Generator

- All the features of the DSO1060 plus a 25 MHz Arbitrary Waveform Generator.
- Waveforms can be saved in the following formats: jpg/bmp graphic file, MS excel/word file
- Can record and save 1000 waveforms
- DC to 25 MHz Arbitrary Waveform Generator

Item# **DSO-8060** New Low Price! **\$519.00**

www.circuitspecialists.com/DSO-8060

Programmable DC Power Supplies

- Up to 10 settings stored in memory
- Optional RS-232, USB, RS-485 adapters
- May be used in series or parallel modes with additional supplies.
- Low output ripple & noise
- LCD display with backlight
- High resolution at 1mV

Model	CSI3644A	CSI3645A	CSI3646A
DC Voltage	0-18V	0-36V	0-72V
DC Current	5A	3A	1.5A
Power (max)	90W	108W	108W
Price	\$199.00	\$199.00	\$199.00

www.CircuitSpecialists.com/inspection-cameras

Ideal for Law Enforcement,
Post Fire Inspection, Plumbing,
Facilities Maintenance,
Security Companies,
& Many Other Uses!

Aardvark II Dual Camera

Wireless Inspection Camera
With Color 3.5" LCD
Recordable Monitor
Your Extended Eyes & Hands!



See It!
Clearly in narrow spots, even in total darkness or underwater.
Find It!
Fast. No more struggling with a mirror & flash light.
Solve It!
Easily, speed up the solution with extended accessories.
Record It!
With the 3.5" LCD recordable monitor, you can capture pictures or record video for documentation.

The Aardvark Wireless Inspection Camera is the only dual camera video borescope on the market today. With both a 17mm camera head that includes three attachable accessories and a 9mm camera head for tighter locations. Both cameras are mounted on 3ft flexible shafts. The flexible shaft makes the Aardvark great for inspecting hard to reach or confined areas like sink drains, AC Vents, engine compartments or anywhere space is limited. The Aardvark II comes with a 3.5 inch color LCD monitor. The monitor is wireless and may be separated from the main unit for ease of operation. Still pictures or video can also be recorded and stored on a 2GB MicroSD card (included). The Aardvark's monitor also has connections for composite video output for a larger monitor/recorder and USB interface for computer connection. Also included is an AC adapter/charger, video cable and USB cable. Optional 3 ft flexible extensions are available to extend the Aardvark's reach (Up to 5 may be added for a total reach of 18 feet!).

Item# **AARDVARK II** **\$199.00**

www.CircuitSpecialists.com/aardvark-ii



Aardvark Nine 9mm Wireless Inspection Camera

With Color 3.5" LCD Recordable
Monitor
Your Extended Eyes & Hands!

Same great Aardvark Wireless Inspection Camera System, but with only the 9mm Camera for a lower cost option!

Item# **AARDVARK NINE** **\$149.00**

www.CircuitSpecialists.com/aardvark-nine



Aardvark Jr 9mm Wireless Inspection Camera

With its small 9mm camera head, the Aardvark Jr allows for easy visual inspection in hard-to-reach areas. Lightweight, handheld design to easily find, diagnose and solve problems with the flexible extended tube and useful accessories.

Item# **AARDVARK JR** **\$79.00**

www.CircuitSpecialists.com/aardvark-jr



Multicore Microcontroller Development Board Propeller P8X32A QuickStart

Simple yet powerful multicore programming on a convenient evaluation board.

Discover multicore microcontroller programming with the Propeller P8X32A on the QuickStart development board. The board includes touch-buttons, LEDs, and access to all I/O pins through an expansion header. Comes pre-loaded with the demonstration code. Power from USB port or use an external power source.

FEATURES

- 32-bit, 8-core P8X32A microcontroller, up to 160 MIPS
- Buffered USB to serial converter with USB bus power
- Eight resistive touch buttons on I/O pins P0-P7
- Eight light blue LEDs on I/O pins P16-P23
- 3.3 V regulator supplies up to 500 mA for projects
- 5 MHz on-board crystal, for DC to 80 MHz operation
- 64 KB EEPROM: 32 KB for code, 32 KB general-purpose
- Pads for sigma-delta A/DC circuitry
- Expansion header to access control signals, Vss, Vdd, and all 32 I/O pins
- Open-source hardware PCB design

KEY SPECIFICATIONS

- Power Requirements: 3.3 or 4 to 9 VDC, up to 500 mA
- Interface: USB, 3.3 V serial, I²C, or others as programmed
- Operating temperature: -40 to +185 °F (-40 to +85 °C)
- Dimensions: 2.0 x 3.0 x 0.36 in (5.0 x 7.6 x 0.84 cm)

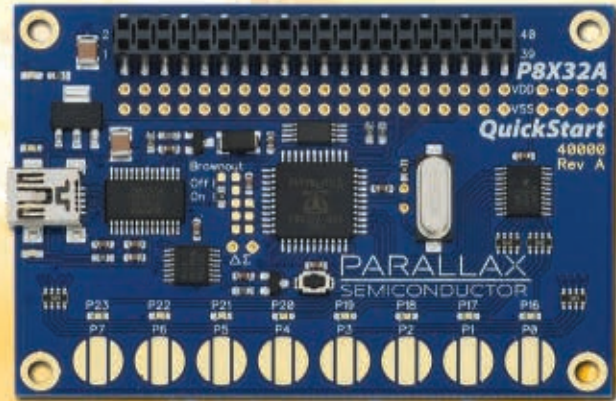

The P8X32A QuickStart development board is an open-source hardware project. The bill of materials and the DipTrace schematic and PCB layout files are released under the Creative Commons Attribution 3.0 license. The example code is released under the MIT License. All of these files are available from the P8X32A QuickStart product page at www.parallax.com.

Order the **P8X32A QuickStart (#40000; \$25.00)** at www.parallax.com or call Sales toll-free at 888-512-1024 (M-F, 7AM-5PM, PDT).

Friendly microcontrollers, legendary resources.™

Prices subject to change without notice. Propeller, Parallax and the Parallax logo are trademarks of Parallax Inc.

PARALLAX 
www.parallax.com

"ParallaxInc" on Twitter, Facebook, and YouTube

