



## Dual Low-Leakage Pico-Amp Diodes

DPAD1            SSTDPAD5  
 DPAD5           SSTDPAD100  
 DPAD50

PRODUCT SUMMARY	
Part Number	$I_R$ Max (pA)
DPAD1	-1
DPAD5/SSTDPAD5	-5
DPAD50	-50
SSTDPAD100	-100

### FEATURES

- Ultralow Leakage: DPAD1 <1 pA
- Ultralow Capacitance: DPAD1 <0.8 pF

### BENEFITS

- Negligible Circuit Leakage Contribution
- Circuit "Transparent" Except to Shunt High-Frequency Spikes

### APPLICATIONS

- Op Amp Input Protection
- Multiplexer Overvoltage Protection

### DESCRIPTION

The DPAD/SSTDPAD series of extremely low-leakage diodes provides a superior alternative to conventional diode technology when reverse current (leakage) must be minimized. These devices feature leakage currents ranging from -1 pA (DPAD1) to -100 pA (SSTDPAD100) to support a wide range of applications.

The low-cost, compact, narrow-body SO-8 (SSTDPAD) package allows maximum circuit performance. Tape- and-reel options are available for automated assembly (see Packaging Information).

The TO-78 and TO-71 (DPAD) hermetically sealed metal cans are available with full military processing per MIL-S-19500 (see Military Information).

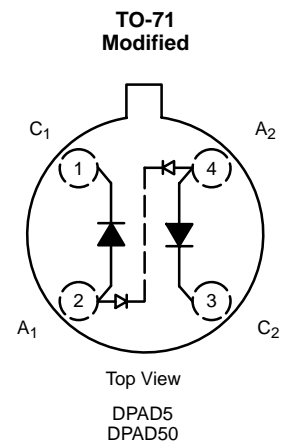
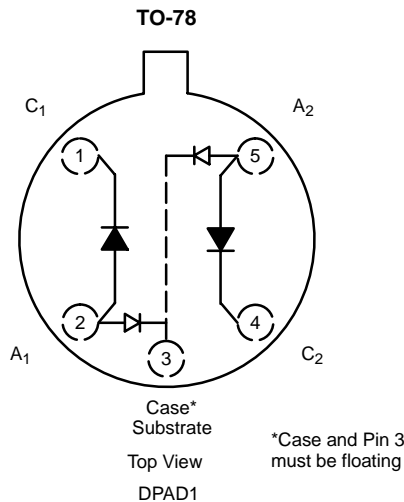
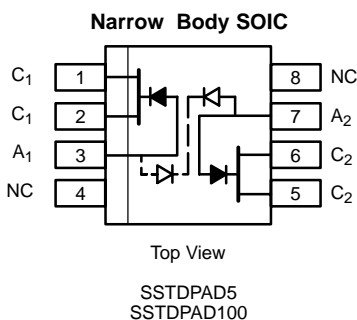

### ABSOLUTE MAXIMUM RATINGS<sup>a</sup>

Forward Current	50 mA
Storage Temperature	-55 to 150°C
Operating Junction Temperature	-55 to 150°C
Lead Temperature (1/16" from case for 10 sec.)	300°C
Total Device Dissipation <sup>b</sup>	500 mW

Notes:

- $T_A = 25^\circ\text{C}$  unless otherwise noted.
- Derate 4 mW/°C at 25°C.

SPECIFICATIONS ( $T_A = 25^\circ\text{C}$ UNLESS OTHERWISE NOTED)							
Parameter	Symbol	Test Conditions	Limits			Unit	
			Min	Typ <sup>a</sup>	Max		
<b>Static</b>							
Reverse Current	$I_R$	$V_R = -20\text{ V}$	DPAD1	-0.2	-1	pA	
			DPAD5/SSTDPAD5	-2	-5		
			DPAD5/SSTDPAD5/DPAD50	-5	-50		
			SSTDPAD100	-10	-100		
Reverse Breakdown Voltage	$BV_R$	$I_R = -1\ \mu\text{A}$	DPAD1	-45	-60	V	
			DPAD5/DPAD50	-45	-55		
			SSTDPAD5/SSTDPAD100	-30	-50		
Forward Voltage Drop	$V_F$	$I_F = 1\text{ mA}$		0.8	1.5		
<b>Dynamic</b>							
Reverse Capacitance	$C_R$	$V_R = -5\text{ V}, f = 1\text{ MHz}$	DPAD1	0.6	0.8	pF	
			DPAD5/DPAD50	1.0	2.0		
			SSTDPAD5/SSTDPAD100	2.0	4.0		
Differential Capacitance	$ C_{R1} - C_{R2} $	$V_{R1} = V_{R2} = -5\text{ V}$ $f = 1\text{ MHz}$	DPAD1	0.07	0.2		
			All Others	0.1	0.5		

Notes:

- Typical values are for DESIGN AID ONLY, not guaranteed nor subject to production testing.

### TYPICAL CHARACTERISTICS ( $T_A = 25^\circ\text{C}$ UNLESS OTHERWISE NOTED)

