

Dual 1 Form A Solid-State Relays

Features

- Dual Channel 1 Form A
- Extremely Low Operating Current
- High-speed Operation
- Isolation Test Voltage 5300 V_{RMS}
- Current-limit Protection
- High Surge Capability
- Linear, ac/dc Operation
- dc-only Option
- Clean, Bounce-free Switching
- Low Power Consumption
- High-reliability Monolithic Receptor
- Surface-mountable

Agency Approvals

- UL - File No. E52744 System Code H or J
- CSA - Certification 093751
- BSI/BABT Cert. No. 7980

Applications

General Telecom Switching

- Telephone Line Interface
- On/off Hook
- Ring Relay
- Break Switch
- Ground Start

Battery-powered Switch Applications

Industrial Controls

- Microprocessor Control of Solenoids, Lights, Motors, Heaters, etc.

Programmable Controllers

Instrumentation

See Application Note 56

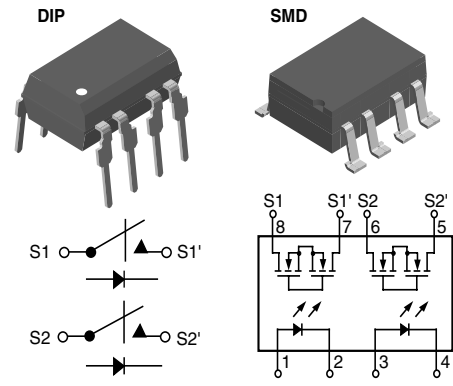

Description

The LH1526 relay is two SPST normally open switches that can replace electromechanical relays in many applications. The relays require a minimal amount of LED drive current to operate, making it ideal for battery powered and power consumption sensitive applications. The relay is constructed using a GaAlAs LED for actuation control and an integrated monolithic die for the switch output. The die is, fabricated in a high-voltage dielectrically isolated technology, comprised of a photodiode array, switch-control circuitry, and MOSFET switches. In addition, the relay employs current-limiting circuitry, enabling it to pass FCC 68.302 and other regulatory surge requirements when overvoltage protection is provided. The relay can be configured for ac/dc or dc-only operation.

Order Information

Part	Remarks
LH1526AAC	8-pin SMD, Tubes
LH1526AACTR	8-pin SMD, Tape and Reel
LH1526AB	8-pin DIP, Tubes

Absolute Maximum Ratings, $T_{amb} = 25\text{ }^{\circ}\text{C}$

Stresses in excess of the absolute Maximum Ratings can cause permanent damage to the device. Functional operation of the device is not implied at these or any other conditions in excess of those given in the operational sections of this document. Exposure to absolute Maximum Ratings for extended periods of time can adversely affect reliability.

SSR

Parameter	Test condition	Symbol	Value	Unit
LED input ratings: continuous forward current		I_F	50	mA
LED input ratings: reverse voltage		V_R	8.0	V
Output operation: DC or peak AC load voltage	$I_L \leq 50\text{ }\mu\text{A}$	V_L	400	V
Continuous DC load current , unidirectional operation pins 4, 6 (+) to pin 5 (-)		I_L	250	mA
Continuous DC load current , two pole operation		I_L	100	mA
Ambient operating temperature range		T_{amb}	- 40 to + 85	$^{\circ}\text{C}$
Storage temperature range		T_{stg}	- 40 to + 150	$^{\circ}\text{C}$
Pin soldering temperature	$t = 10\text{ s max}$	T_{sld}	260	$^{\circ}\text{C}$
Input/output isolation test voltage	$t = 1.0\text{ s}, I_{ISO} = 10\text{ }\mu\text{A max}$	V_{ISO}	5300	V_{RMS}
Power dissipation		P_{diss}	600	mW

Electrical Characteristics, $T_{amb} = 25\text{ }^{\circ}\text{C}$

Minimum and maximum values are testing requirements. Typical values are characteristics of the device and are the result of engineering evaluations. Typical values are for information only and are not part of the testing requirements.

Input

Parameter	Test condition	Symbol	Min	Typ.	Max	Unit
LED forward current, switch turn-on	$I_L = 70\text{ mA}, t = 10\text{ ms}$	I_{Fon}		0.3	0.5	mA
LED forward current, switch turn-off	$V_L = \pm 350\text{ V}, t = 100\text{ ms}$	I_{Foff}	0.01	0.1		mA
LED forward voltage	$I_F = 1.5\text{ mA}$	V_F	0.80	1.15	1.40	V

Output

Parameter	Test condition	Symbol	Min	Typ.	Max	Unit
ON-resistance: ac/dc, each pole	$I_F = 1.5\text{ mA}, I_L = \pm 50\text{ mA}$	R_{ON}	17	25	36	Ω
Off-resistance	$I_F = 0\text{ mA}, V_L = \pm 100\text{ V}$	R_{OFF}		5000		$\text{G}\Omega$
Current limit	$I_F = 1.5\text{ mA}, t = 5.0\text{ ms}, V_L = 7.0\text{ V}$	I_{LMT}	170	210	270	mA
Off-state leakage current	$I_F = 0\text{ mA}, V_L = \pm 100\text{ V}$	I_O		0.04	200	nA
	$I_F = 0\text{ mA}, V_L = \pm 400\text{ V}$	I_O			1.0	μA
Output capacitance	$I_F = 0\text{ mA}, V_L = 1.0\text{ V}$	C_O		37		pF
	$I_F = 0\text{ mA}, V_L = 50\text{ V}$	C_O		13		pF
Switch offset	$I_F = 5.0\text{ mA}$	V_{OS}		0.25		μV

Transfer

Parameter	Test condition	Symbol	Min	Typ.	Max	Unit
Input/output capacitance	$V_{ISO} = 1.0\text{ V}$	C_{ISO}		0.8		pF
Turn-on time	$I_F = 1.5\text{ mA}, I_L = 50\text{ mA}$	t_{on}		1.00		ms
	$I_F = 5.0\text{ mA}, I_L = 50\text{ mA}$	t_{on}		0.5	1.0	ms
Turn-off time	$I_F = 1.5\text{ mA}, I_L = 50\text{ mA}$	t_{off}		0.20		ms
	$I_F = 5.0\text{ mA}, I_L = 50\text{ mA}$	t_{off}		0.4	0.9	ms

Typical Characteristics ($T_{amb} = 25\text{ }^\circ\text{C}$ unless otherwise specified)

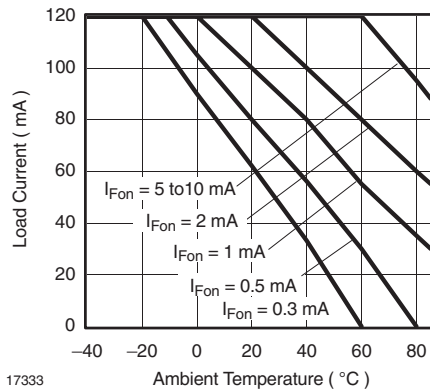

Figure 1. Recommended Operating Conditions

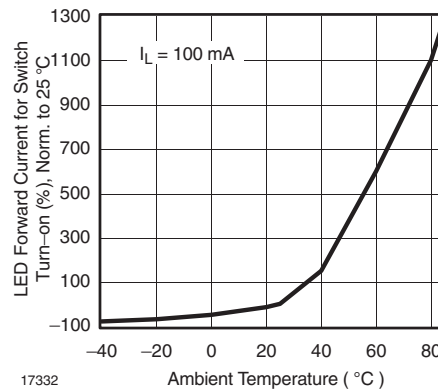

Figure 3. LED Current for Switch Turn-on vs. Temperature

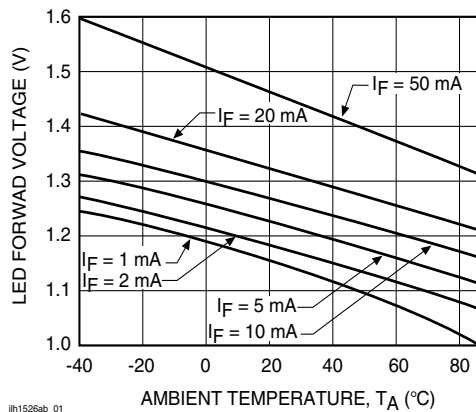

Figure 2. LED Voltage vs. Temperature

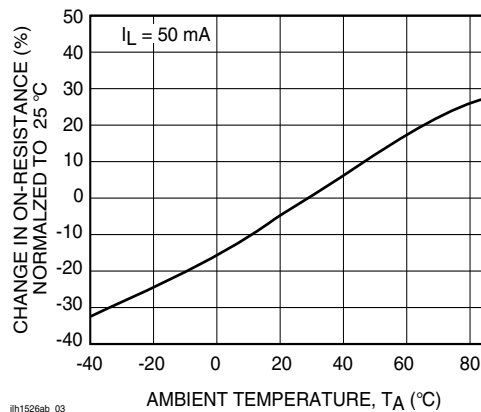

Figure 4. ON-Resistance vs. Temperature

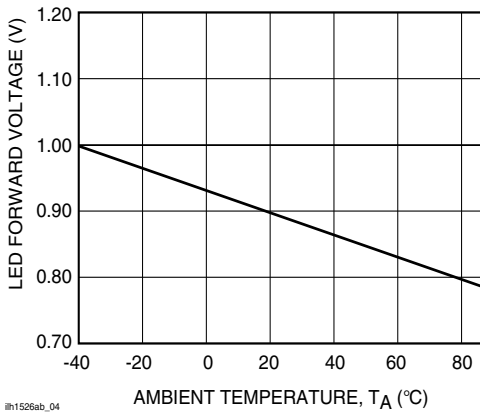

Figure 5. LED Dropout Voltage vs. Temperature

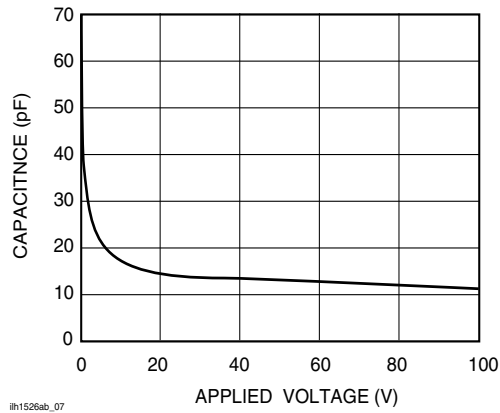

Figure 8. Switch Capacitance vs. Applied Voltage

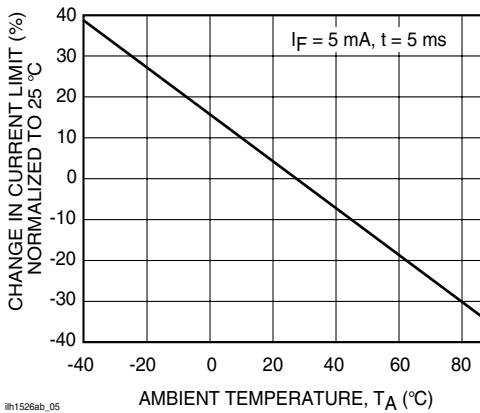

Figure 6. Current Limit vs. Temperature

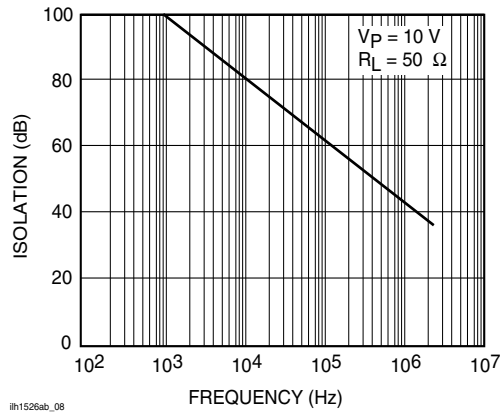

Figure 9. Output Isolation

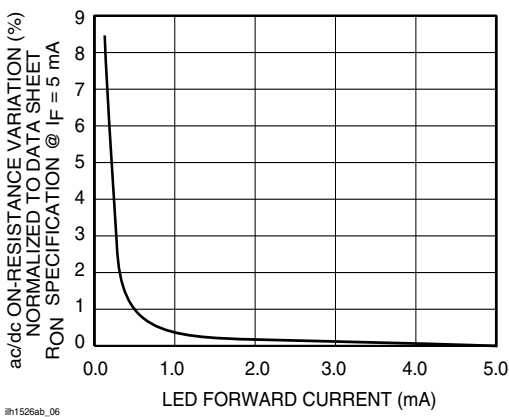

Figure 7. Variation in ON-Resistance vs. LED Current

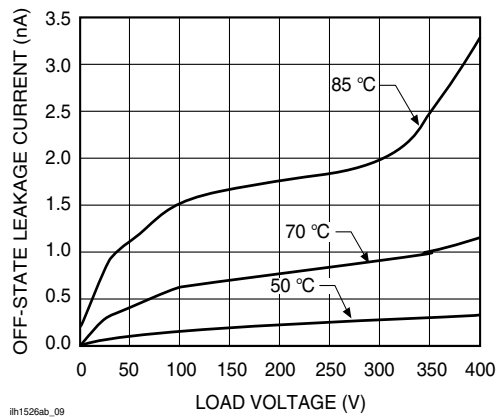
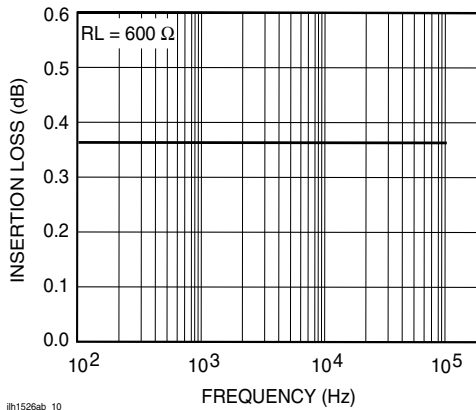
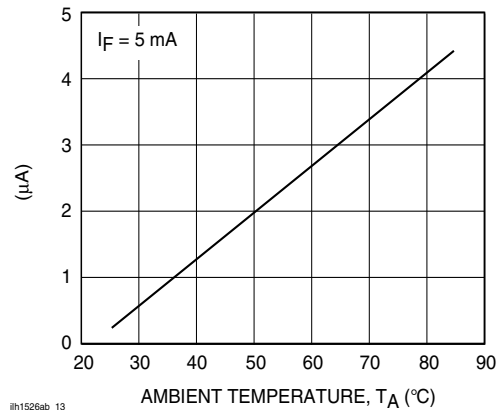

Figure 10. Leakage Current vs. Applied Voltage at Elevated Temperatures



ih1526ab_10

Figure 11. Insertion Loss vs. Frequency



ih1526ab_13

Figure 14. Switch Offset Voltage vs. Temperature

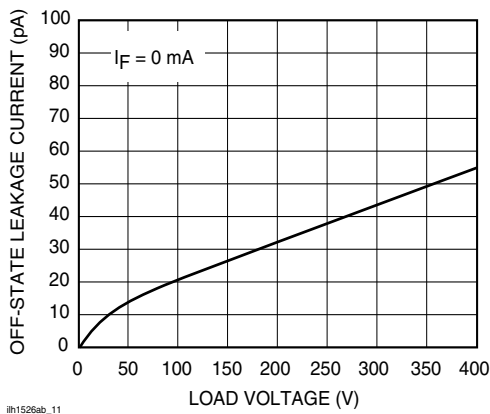

ih1526ab_11

Figure 12. Leakage Current vs. Applied Voltage

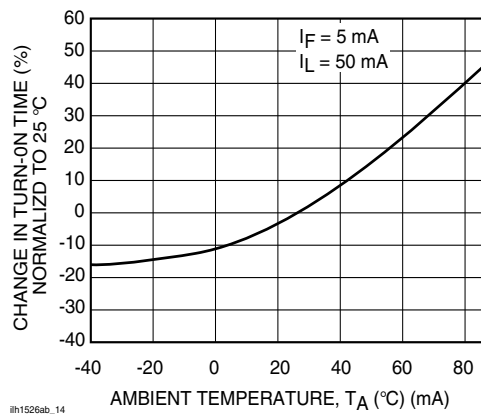

ih1526ab_14

Figure 15. Turn-on Time vs. Temperature

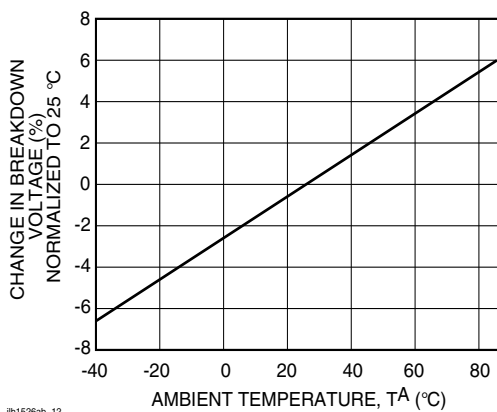

ih1526ab_12

Figure 13. Switch Breakdown Voltage vs. Temperature

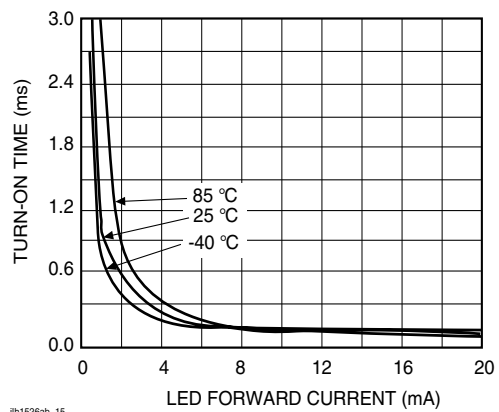

ih1526ab_15

Figure 16. Turn-on Time vs. LED Current

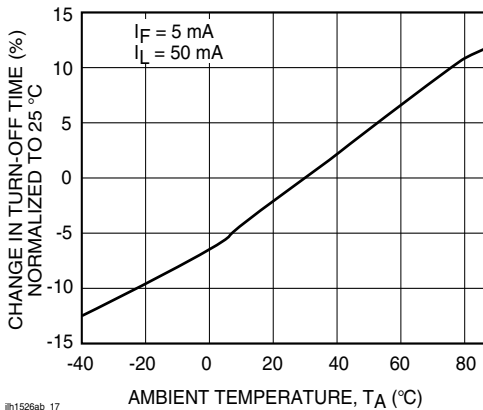

Figure 17. Turn-off Time vs. Temperature

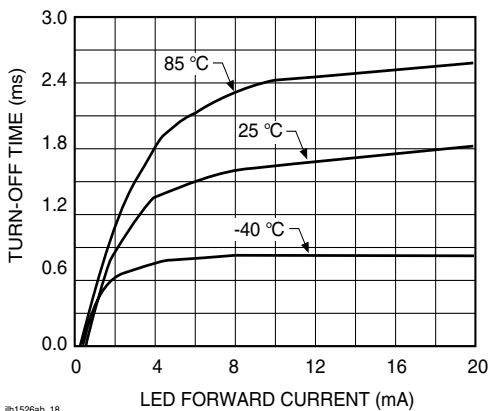

Figure 18. Turn-off Time vs. LED Current

Applications Input Control

The LH1526 low turn-on current SSR has highly sensitive photodetection circuits that will detect even the most minute currents flowing through the LED. Leakage current must be considered when designing a circuit to turn on and off these relays.

Figure 19 shows a typical logic circuit for providing LED drive current. R1 is the input resistor that limits the amount of current flowing through the LED. For 5.0 V operation, a 2700 Ω resistor will limit the drive current to about 1.4 mA. Where high-speed actuation is desirable, use a lower value resistor for R1. An additional RC peaking circuit is not required with the LH1526 relay.

R2 is an optional pull-up resistor which pulls the logic level high output (V_{OH}) up toward the VS potential. The pull-up resistance is set at a high value to minimize the overall current drawn from the VS. The primary purpose of this resistor is to keep the differential voltage across the LED below its turn-on threshold. LED dropout voltage is graphed vs. temperature in the Typical Performance Characteristics section. When the logic gate is high, leakage current will flow through R2. R2 will draw up to 8 mA before developing a voltage potential which might possibly turn on the LED.

Each application should be evaluated, over the full operating temperature range to make sure that leakage current through the input control LED is kept to a value less than the minimum LED forward current for switch turn-off specification.

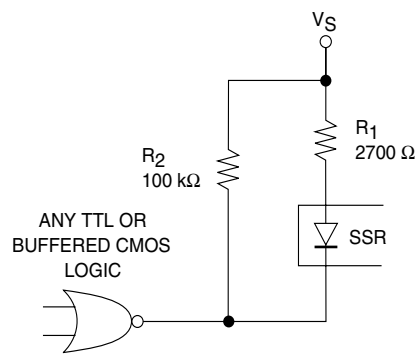
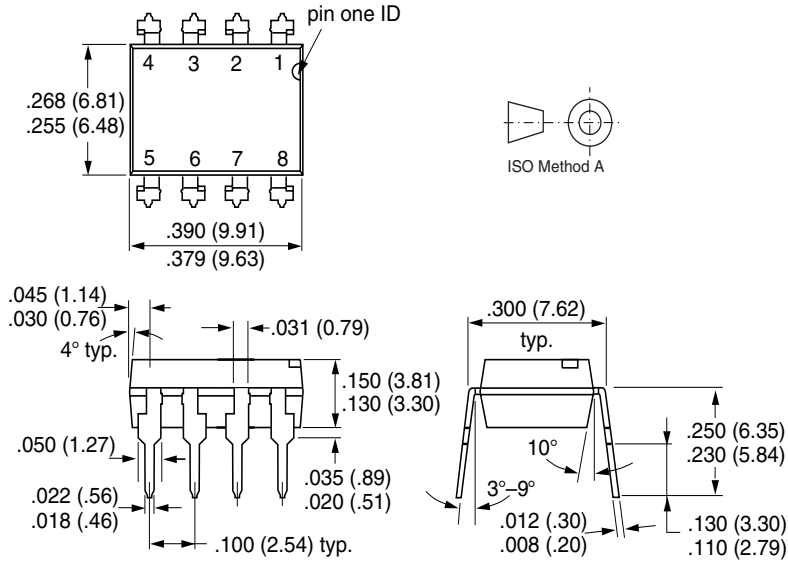

Figure 19. Input Control Circuit

Package Dimensions in Inches (mm)

DIP



i178008

SMD

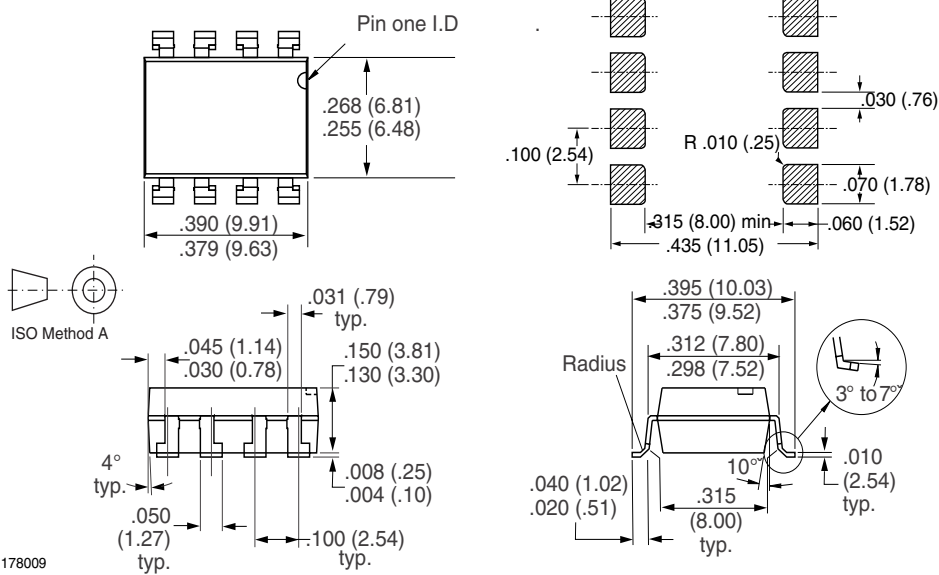

i178009

Ozone Depleting Substances Policy Statement

It is the policy of **Vishay Semiconductor GmbH** to

1. Meet all present and future national and international statutory requirements.
2. Regularly and continuously improve the performance of our products, processes, distribution and operating systems with respect to their impact on the health and safety of our employees and the public, as well as their impact on the environment.

It is particular concern to control or eliminate releases of those substances into the atmosphere which are known as ozone depleting substances (ODSs).

The Montreal Protocol (1987) and its London Amendments (1990) intend to severely restrict the use of ODSs and forbid their use within the next ten years. Various national and international initiatives are pressing for an earlier ban on these substances.

Vishay Semiconductor GmbH has been able to use its policy of continuous improvements to eliminate the use of ODSs listed in the following documents.

1. Annex A, B and list of transitional substances of the Montreal Protocol and the London Amendments respectively
2. Class I and II ozone depleting substances in the Clean Air Act Amendments of 1990 by the Environmental Protection Agency (EPA) in the USA
3. Council Decision 88/540/EEC and 91/690/EEC Annex A, B and C (transitional substances) respectively.

Vishay Semiconductor GmbH can certify that our semiconductors are not manufactured with ozone depleting substances and do not contain such substances.

**We reserve the right to make changes to improve technical design
and may do so without further notice.**

Parameters can vary in different applications. All operating parameters must be validated for each customer application by the customer. Should the buyer use Vishay Semiconductors products for any unintended or unauthorized application, the buyer shall indemnify Vishay Semiconductors against all claims, costs, damages, and expenses, arising out of, directly or indirectly, any claim of personal damage, injury or death associated with such unintended or unauthorized use.

Vishay Semiconductor GmbH, P.O.B. 3535, D-74025 Heilbronn, Germany
Telephone: 49 (0)7131 67 2831, Fax number: 49 (0)7131 67 2423