

PRELIMINARY - May 1, 2000

TEL:805-498-2111 FAX:805-498-3804 WEB:http://www.semtech.com

DESCRIPTION

The SC1540 and SC1540A are high performance low dropout positive voltage regulators designed for use in applications where power management is critical, such as battery powered systems. Additionally, the SC1540(A) provides excellent regulation over variations in line, load and temperature. Outstanding features include low dropout performance at rated current, fast transient response, internal current limiting and thermal shutdown protection of the output device. A very low quiescent current of 10 μ A in shutdown mode reduces power dissipation. With three voltage options available, the SC1540(A) comes in the popular SO-8 surface mount package.

APPLICATIONS

- Active SCSI termination
- Low voltage microcontrollers
- Switching power supply post-regulator

BLOCK DIAGRAM

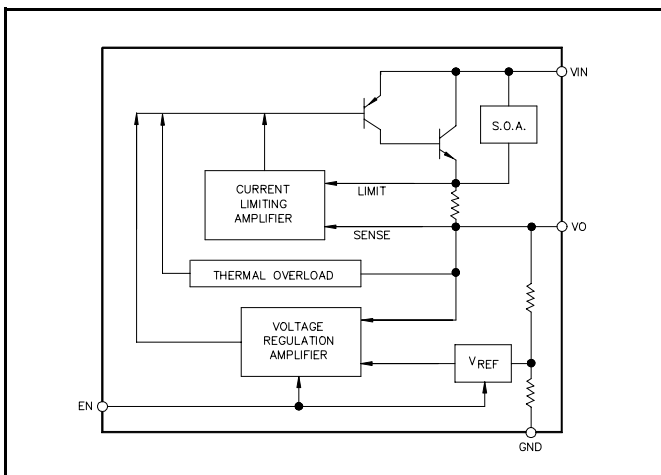

PIN CONFIGURATIONS

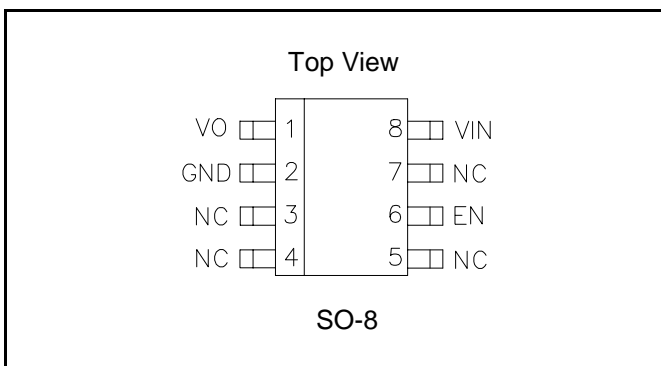

FEATURES

- Low dropout performance, 1.3V max
- Full current rating over line and temperature
- Fast transient response
- $\pm 2\%$ total output regulation over line, load and temperature
- 10 μ A max. quiescent current in shutdown
- Three fixed output voltages
- Line regulation 0.2% max.
- Load regulation 0.4% max.
- SO-8 package

ORDERING INFORMATION

DEVICE ⁽¹⁾⁽²⁾	OUTPUT CURRENT	PACKAGE
SC1540CS-X.X	300mA	SO-8
SC1540ACS-X.X	500mA	SO-8

Notes:

(1) Where X.X denotes voltage options. Available voltages are: 1.8V, 2.5V and 3.3V. Contact factory for additional voltage options.

(2) Only available in tape and reel packaging (suffix '.TR') e.g. SC1540CS-X.X-.TR.

ABSOLUTE MAXIMUM RATINGS

Parameter	Symbol	Maximum	Units
Maximum Input Pin Voltage	VIN, EN	7	V
Power Dissipation	P _D	Internally Limited	W
Thermal Resistance Junction to Case SO-8	θ_{JC}	47	$^{\circ}$ C/W
Thermal Resistance Junction to Ambient SO-8 ⁽¹⁾	θ_{JA}	65	$^{\circ}$ C/W
Operating Junction Temperature Range	T _J	0 to 125	$^{\circ}$ C
Storage Temperature Range	T _{STG}	-65 to 150	$^{\circ}$ C
Lead Temperature (Soldering) 10 Sec	T _{LEAD}	260	$^{\circ}$ C

Notes:

(1) 2 inch square of 1/16" FR-4, double sided, 1 oz. minimum copper weight.

PRELIMINARY - May 1, 2000

ELECTRICAL CHARACTERISTICS

 Unless otherwise specified: $I_o = 0\text{mA}$ to 300mA (500mA for SC1540A), $EN = VIN$

 1.5V Option: $VIN = 2.9\text{V}$ to 7.0V

 2.5V Option: $VIN = 3.9\text{V}$ to 7.0V

 3.3V Option: $VIN = 4.7\text{V}$ to 7.0V

 Values in **bold** apply over full operating temperature range.

Parameter	Symbol	Test Conditions	Test Limits			Units
			Min	Typ	Max	
Output Voltage ⁽¹⁾	VO	VIN = 5V, $I_o = 0\text{mA}$	0.99 VO	VO	1.01 VO	V
			0.98 VO 	VO	1.02 VO 	
Line Regulation ⁽¹⁾	REG _(LINE)	$I_o = 10\text{mA}$		0.035	0.2	%
Load Regulation ⁽¹⁾	REG _(LOAD)	VIN = 5V		0.2	0.4	%
Dropout Voltage ⁽¹⁾⁽²⁾ SC1540 SC1540A	V _D	$I_o = 300\text{mA}$ $I_o = 500\text{mA}$		1.10	1.30	V
Current Limit ⁽¹⁾ SC1540 SC1540A	I _{CL}		330 550			mA
Quiescent Current	I _Q	VIN = 5V, EN = VIN		5	7	mA
					10	
		VIN = 5V, EN < 0.25V		6	8	μA
					10	
Enable Pin Control Voltage	EN	Device OFF	0.25	0.45		V
		Device ON		(VO+0.5)	(VO+0.8)	
Enable Pin Current	I _{EN}	EN = 0V, VIN = 5V (OFF)		0.1	1.0	μA
		EN = VIN = 5V (ON)		15	25	
Temperature Coefficient	T _C			0.005		%/°C
Temperature Stability	T _S			0.5		%
RMS Output Noise ⁽³⁾	V _N			0.003		%V _O
Ripple Rejection Ratio ⁽⁴⁾	R _A	VIN = 5V	60	72		dB

NOTES:

(1) Low duty cycle pulse testing with Kelvin connections required.

 (2) $\Delta V_{OUT}, \Delta V_{REF} = 1\%$

(3) Bandwidth of 10 Hz to 10kHz.

(4) 120Hz input ripple.

PRELIMINARY - May 1, 2000

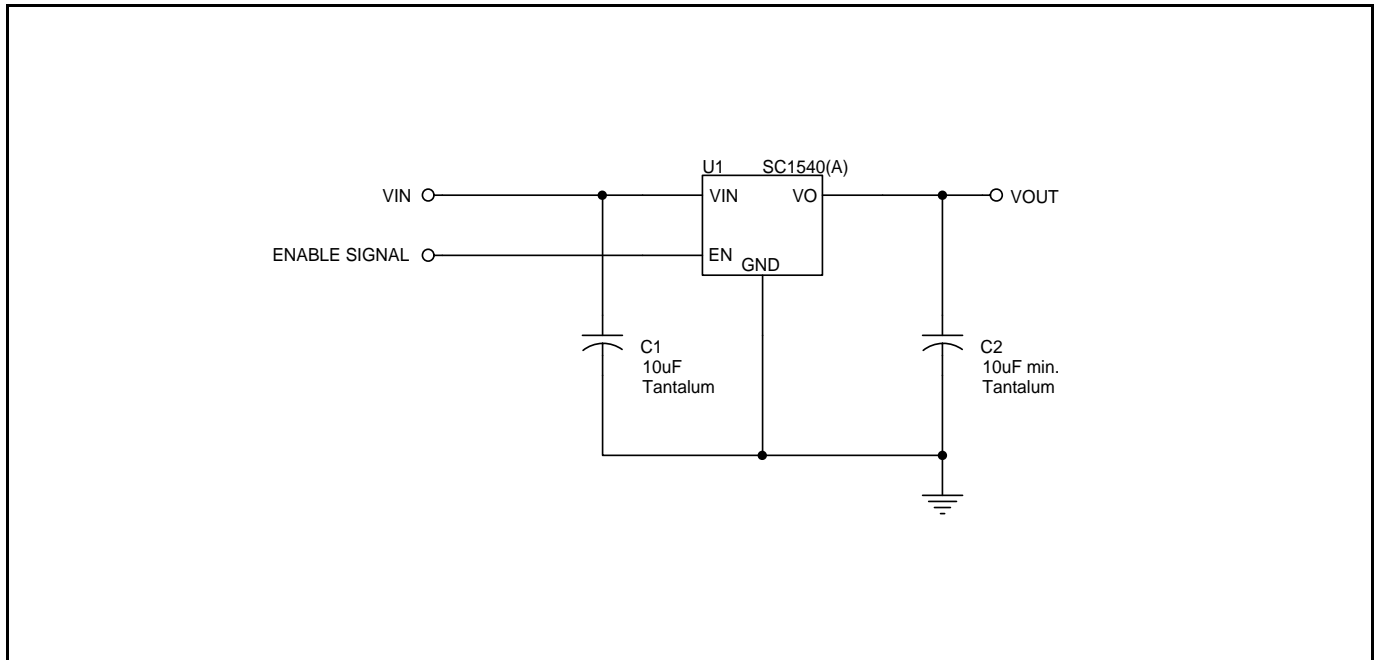
TYPICAL APPLICATION**NOTES**

- (1) Input and output capacitors should be located close to the device.
- (2) Connect all pins to PCB for optimal thermal characteristics.
- (3) Increasing the output capacitor value will improve the overall transient response.
- (4) The device is enabled when EN = VIN, and shut down when EN is pulled to ground. EN should not be taken higher than VIN. A CMOS signal referenced to VIN would be ideal for switching the SC1540(A) on and off.

PRELIMINARY - May 1, 2000

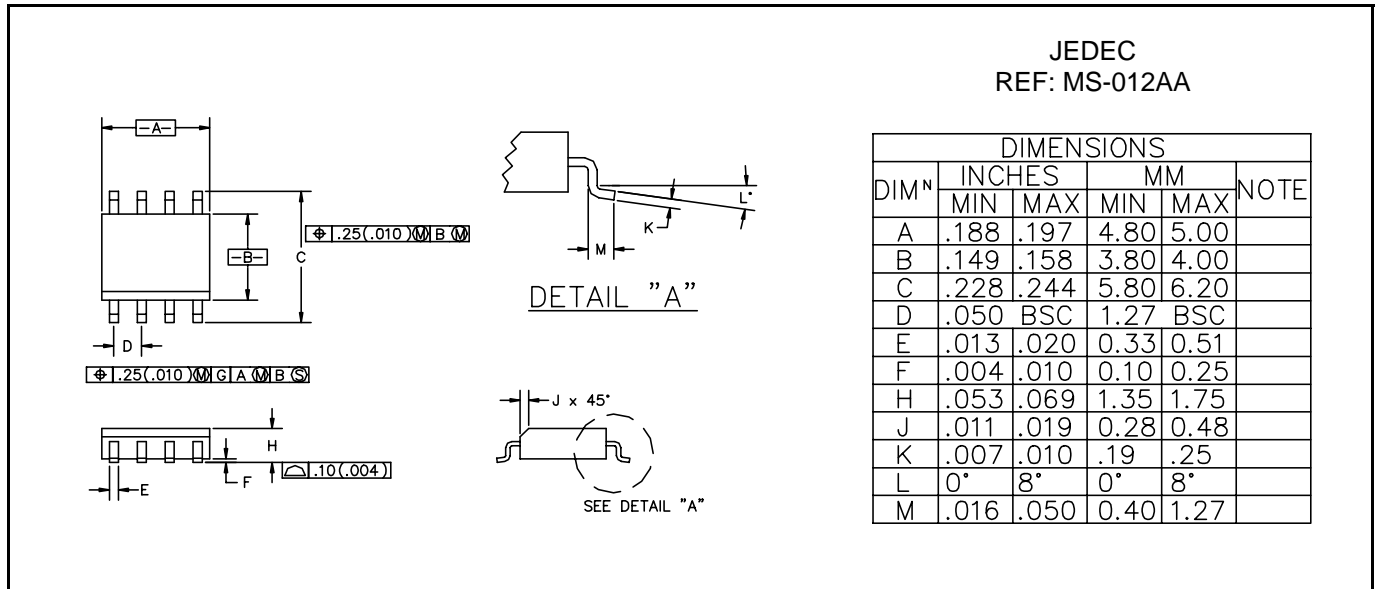
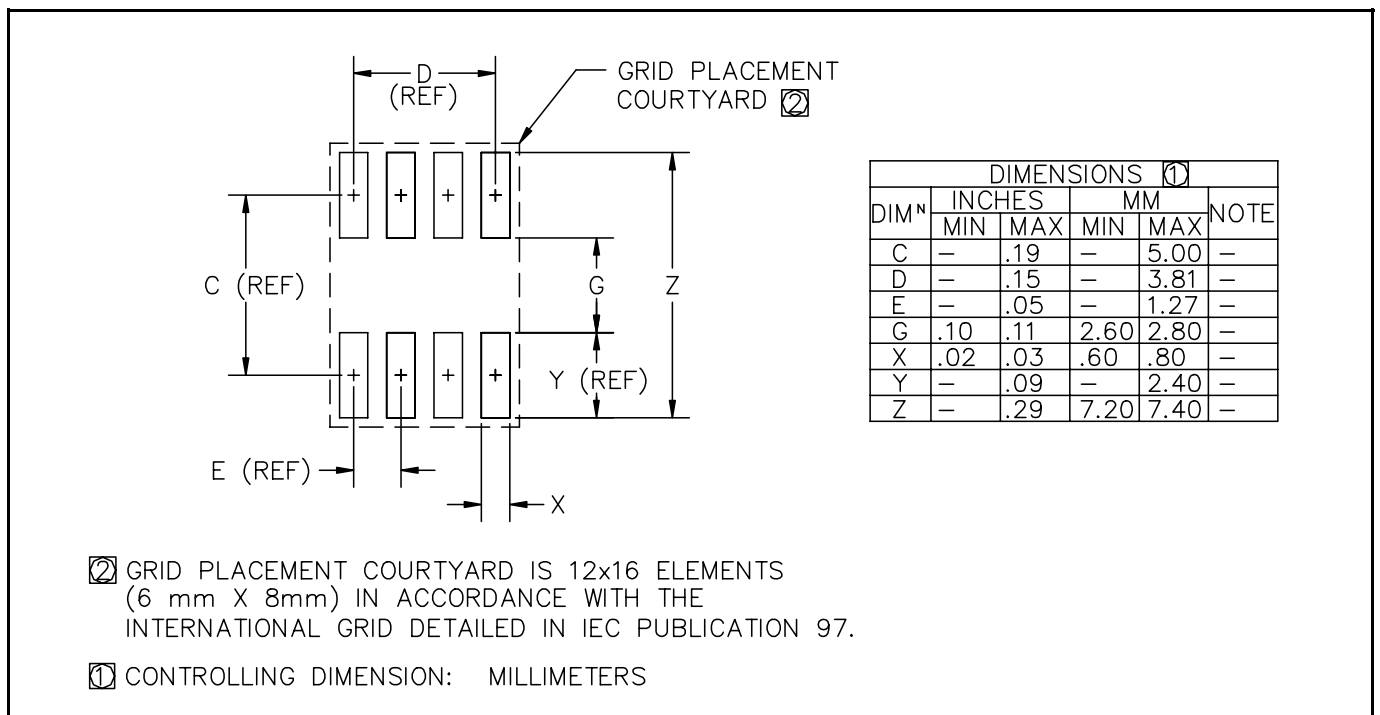
OUTLINE DRAWING - SO-8

LAND PATTERN - SO-8⁽¹⁾

Note:

 (1) More copper area should be used to lower $R_{TH(J-A)}$ as needed.

ECN00-1038