

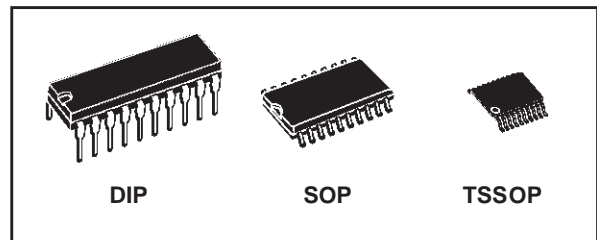

74AC373

OCTAL D-TYPE LATCH WITH 3 STATE OUTPUTS (NON INVERTED)

- HIGH SPEED: $t_{PD} = 5\text{ns}$ (TYP.) at $V_{CC} = 5\text{V}$
- LOW POWER DISSIPATION:
 $I_{CC} = 4\mu\text{A}$ (MAX.) at $T_A=25^\circ\text{C}$
- HIGH NOISE IMMUNITY:
 $V_{NIH} = V_{NIL} = 28\% V_{CC}$ (MIN.)
- 50Ω TRANSMISSION LINE DRIVING CAPABILITY
- SYMMETRICAL OUTPUT IMPEDANCE:
 $|I_{OH}| = I_{OL} = 24\text{mA}$ (MIN)
- BALANCED PROPAGATION DELAYS:
 $t_{PLH} \approx t_{PHL}$
- OPERATING VOLTAGE RANGE:
 V_{CC} (OPR) = 2V to 6V
- PIN AND FUNCTION COMPATIBLE WITH 74 SERIES 373
- IMPROVED LATCH-UP IMMUNITY



ORDER CODES

PACKAGE	TUBE	T & R
DIP	74AC373B	
SOP	74AC373M	74AC373MTR
TSSOP		74AC373TTR

DESCRIPTION

The 74AC373 is a high-speed CMOS OCTAL D-TYPE LATCH with 3 STATE OUTPUT NON INVERTING fabricated with sub-micron silicon gate and double-layer metal wiring C²MOS technology.

These 8 bit D-Type latch are controlled by a latch enable input (LE) and an output enable input (\overline{OE}). While the LE inputs is held at a high level, the Q outputs will follow the data input. When the LE is taken low, the Q outputs will be latched at the

logic level of D input data. While the (\overline{OE}) input is low, the 8 outputs will be in a normal logic state (high or low logic level); while \overline{OE} is in high level the outputs will be in a high impedance state.

This device is designed to interface directly High Speed CMOS systems with TTL and NMOS components.

All inputs and outputs are equipped with protection circuits against static discharge, giving them 2KV ESD immunity and transient excess voltage.

PIN CONNECTION AND IEC LOGIC SYMBOLS

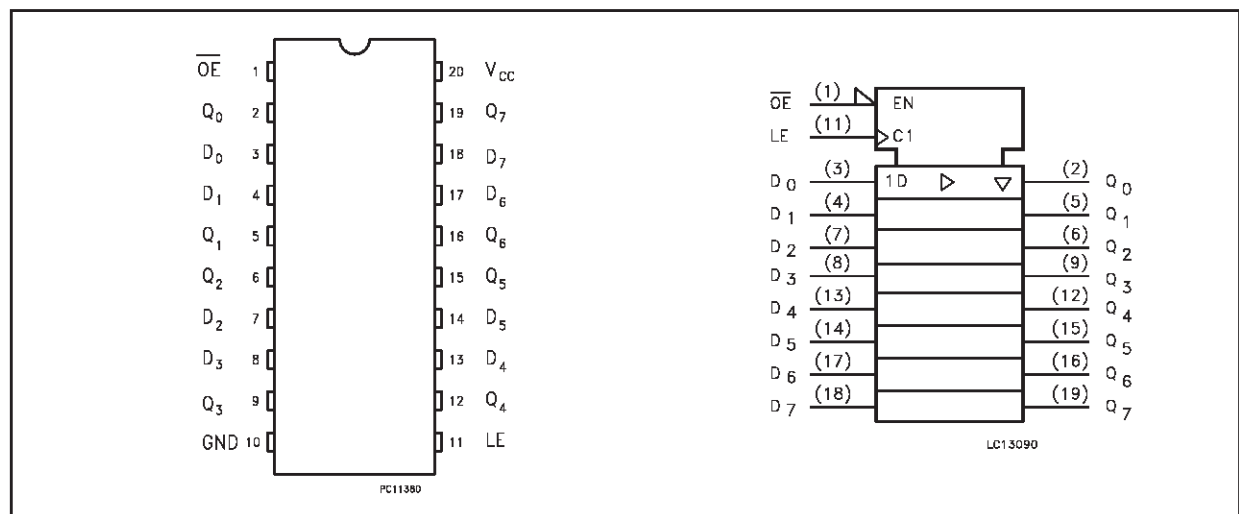

INPUT AND OUTPUT EQUIVALENT CIRCUIT

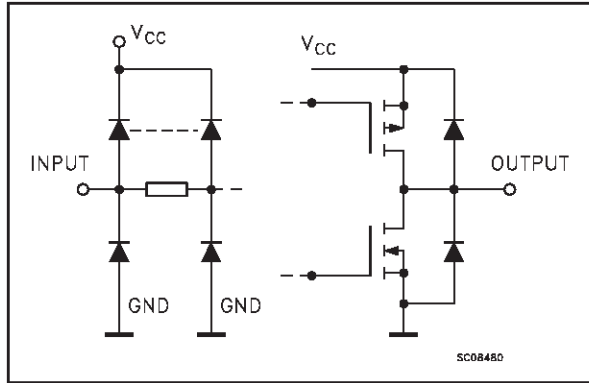

PIN DESCRIPTION

PIN No	SYMBOL	NAME AND FUNCTION
1	\overline{OE}	3 State Output Enable Input (Active LOW)
2, 5, 6, 9, 12, 15, 16, 19	Q0 to Q7	Data Inputs
3, 4, 7, 8, 13, 14, 17, 18	D0 to D7	3-State Outputs
11	LE	Latch Enable Input
10	GND	Ground (0V)
20	V _{CC}	Positive Supply Voltage

TRUTH TABLE

INPUTS			OUTPUT
\overline{OE}	LE	D	Q
H	X	X	Z
L	L	X	NO CHANGE
L	H	L	L
L	H	H	H

X : Don't Care

Z : High Impedance

NOTE: Outputs are latched at the time when the input is taken LOW logic level

LOGIC DIAGRAM

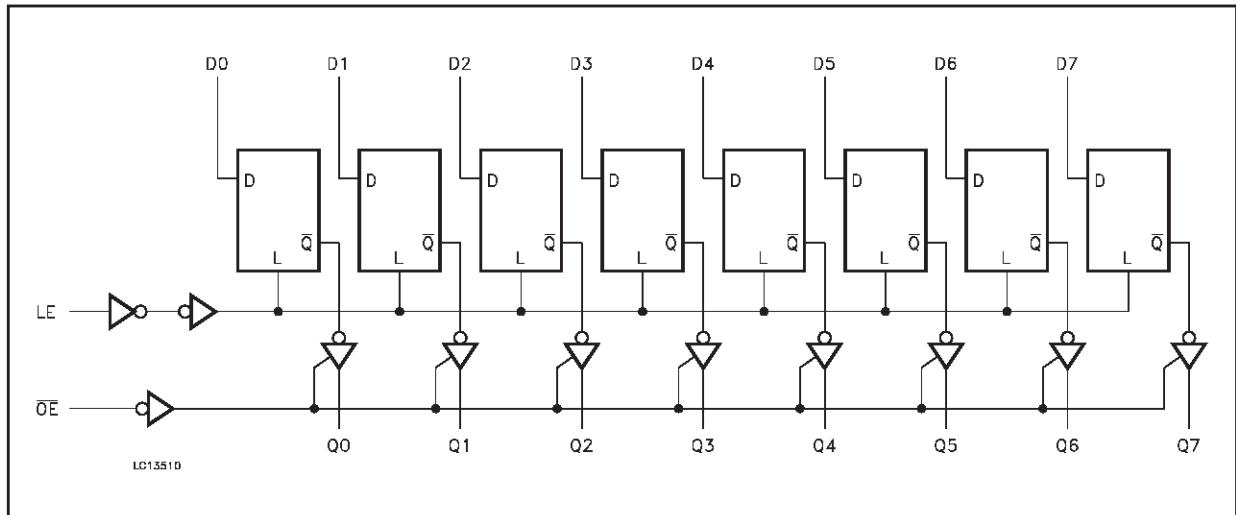

This logic diagram has not been used to estimate propagation delays

ABSOLUTE MAXIMUM RATINGS

Symbol	Parameter	Value	Unit
V_{CC}	Supply Voltage	-0.5 to +7	V
V_I	DC Input Voltage	-0.5 to $V_{CC} + 0.5$	V
V_O	DC Output Voltage	-0.5 to $V_{CC} + 0.5$	V
I_{IK}	DC Input Diode Current	± 20	mA
I_{OK}	DC Output Diode Current	± 20	mA
I_O	DC Output Current	± 50	mA
I_{CC} or I_{GND}	DC V_{CC} or Ground Current	± 400	mA
T_{stg}	Storage Temperature	-65 to +150	°C
T_L	Lead Temperature (10 sec)	300	°C

Absolute Maximum Ratings are those values beyond which damage to the device may occur. Functional operation under these conditions is not implied.

RECOMMENDED OPERATING CONDITIONS

Symbol	Parameter	Value	Unit
V_{CC}	Supply Voltage	2 to 6	V
V_I	Input Voltage	0 to V_{CC}	V
V_O	Output Voltage	0 to V_{CC}	V
T_{op}	Operating Temperature	-55 to 125	°C
dt/dv	Input Rise and Fall Time $V_{CC} = 3.0, 4.5$ or $5.5V$ (note 1)	8	ns/V

1) V_{IN} from 30% to 70% of V_{CC}

DC SPECIFICATIONS

Symbol	Parameter	Test Condition		Value						Unit	
		V _{CC} (V)		T _A = 25°C			-40 to 85°C		-55 to 125°C		
				Min.	Typ.	Max.	Min.	Max.	Min.		Max.
V _{IH}	High Level Input Voltage	3.0	V _O = 0.1 V or V _{CC} -0.1V	2.1	1.5		2.1		2.1		V
		4.5		3.15	2.25		3.15		3.15		
		5.5		3.85	2.75		3.85		3.85		
V _{IL}	Low Level Input Voltage	3.0	V _O = 0.1 V or V _{CC} -0.1V		1.5	0.9		0.9		0.9	V
		4.5			2.25	1.35		1.35		1.35	
		5.5			2.75	1.65		1.65		1.65	
V _{OH}	High Level Output Voltage	3.0	I _O =-50 μA	2.9	2.99		2.9		2.9		V
		4.5	I _O =-50 μA	4.4	4.49		4.4		4.4		
		5.5	I _O =-50 μA	5.4	5.49		5.4		5.4		
		3.0	I _O =-12 mA	2.56			2.46		2.4		
		4.5	I _O =-24 mA	3.86			3.76		3.7		
		5.5	I _O =-24 mA	4.86			4.76		4.7		
V _{OL}	Low Level Output Voltage	3.0	I _O =50 μA		0.002	0.1		0.1		0.1	V
		4.5	I _O =50 μA		0.001	0.1		0.1		0.1	
		5.5	I _O =50 μA		0.001	0.1		0.1		0.1	
		3.0	I _O =12 mA			0.36		0.44		0.5	
		4.5	I _O =24 mA			0.36		0.44		0.5	
		5.5	I _O =24 mA			0.36		0.44		0.5	
I _I	Input Leakage Current	5.5	V _I = V _{CC} or GND			± 0.1		± 1		± 1	μA
I _{oz}	High Impedance Output Leakage Current	5.5	V _I = V _{IH} or V _{IL} V _O = V _{CC} or GND			± 0.5		± 5		± 10	μA
I _{CC}	Quiescent Supply Current	5.5	V _I = V _{CC} or GND			4		40		80	μA
I _{OLD}	Dynamic Output Current (note 1, 2)	5.5	V _{OLD} = 1.65 V max					75		50	mA
I _{OHD}			V _{OHD} = 3.85 V min					-75		-50	mA

1) Maximum test duration 2ms, one output loaded at time

2) Incident wave switching is guaranteed on transmission lines with impedances as low as 50Ω

AC ELECTRICAL CHARACTERISTICS ($C_L = 50 \text{ pF}$, $R_L = 500 \Omega$, Input $t_r = t_f = 3\text{ns}$)

Symbol	Parameter	Test Condition		Value						Unit	
		V_{CC} (V)		$T_A = 25^\circ\text{C}$			$-40 \text{ to } 85^\circ\text{C}$		$-55 \text{ to } 125^\circ\text{C}$		
				Min.	Typ.	Max.	Min.	Max.	Min.		Max.
t_{PLH} t_{PHL}	Propagation Delay Time LE to Q	3.3(*)			6.5	12.0		14.0		14.0	ns
		5.0(**)			5.0	9.5		10.5		10.5	
t_{PLH} t_{PHL}	Propagation Delay Time D to Q	3.3(*)			6.5	12.0		14.0		14.0	ns
		5.0(**)			5.0	9.5		10.5		10.5	
t_{PZL} t_{PZH}	Output Enable Time	3.3(*)			7.0	11.0		13.0		13.0	ns
		5.0(**)			5.0	8.5		9.5		9.5	
t_{PLZ} t_{PHZ}	Output Disable Time	3.3(*)			7.5	12.0		13.0		13.0	ns
		5.0(**)			6.5	9.0		10.0		10.0	
t_W	CLOCK Pulse Width HIGH or LOW	3.3(*)			1.5	5.5		6.0		6.0	ns
		5.0(**)			1.5	4.0		4.5		4.5	
t_s	Setup Time D to CLOCK, HIGH or LOW	3.3(*)			0.5	5.5		6.0		6.0	ns
		5.0(**)			0.5	4.0		4.5		4.5	
t_h	Hold Time D to CLOCK, HIGH or LOW	3.3(*)			-0.5	1.0		5.0		5.0	ns
		5.0(**)			-0.5	1.0		5.0		5.0	

(*) Voltage range is $3.3\text{V} \pm 0.3\text{V}$ (**) Voltage range is $5.0\text{V} \pm 0.5\text{V}$
CAPACITIVE CHARACTERISTICS

Symbol	Parameter	Test Condition		Value						Unit	
		V_{CC} (V)		$T_A = 25^\circ\text{C}$			$-40 \text{ to } 85^\circ\text{C}$		$-55 \text{ to } 125^\circ\text{C}$		
				Min.	Typ.	Max.	Min.	Max.	Min.		Max.
C_{IN}	Input Capacitance	5.0			4						pF
C_{OUT}	Output Capacitance	5.0			8						pF
C_{PD}	Power Dissipation Capacitance (note 1)	5.0	$f_{IN} = 10\text{MHz}$		20						pF

1) C_{PD} is defined as the value of the IC's internal equivalent capacitance which is calculated from the operating current consumption without load. (Refer to Test Circuit). Average operating current can be obtained by the following equation. $I_{CC(OPR)} = C_{PD} \times V_{CC} \times f_{IN} + I_{CC}/n$ (per circuit)

TEST CIRCUIT

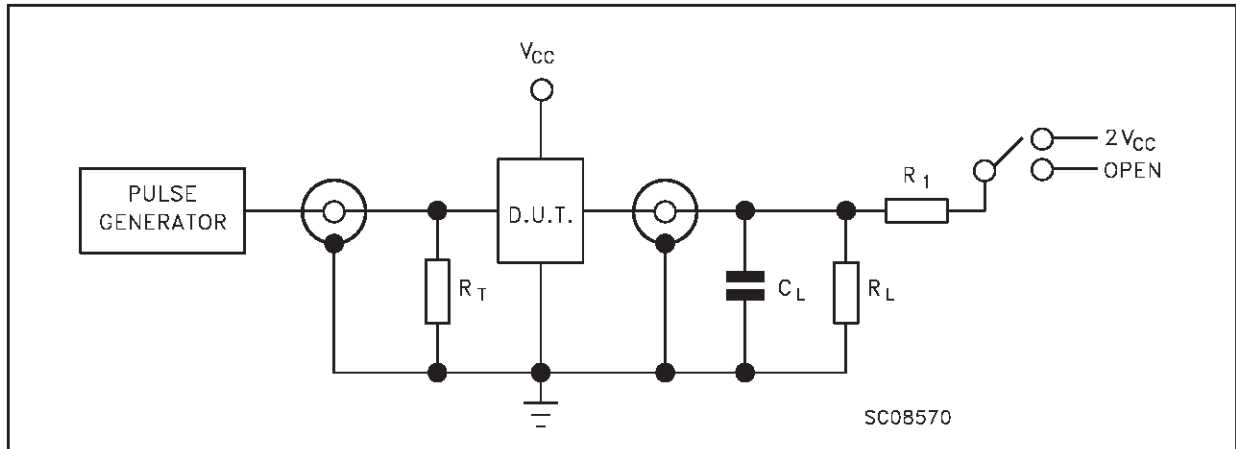

TEST	SWITCH
t_{PLH} , t_{PHL}	Open
t_{PZL} , t_{PLZ}	$2V_{CC}$
t_{PZH} , t_{PHZ}	Open

C_L = 50pF or equivalent (includes jig and probe capacitance)
 $R_L = R_1 = 500\Omega$ or equivalent
 $R_T = Z_{OUT}$ of pulse generator (typically 50 Ω)

WAVEFORM 1: LE TO Qn PROPAGATION DELAYS, LE MINIMUM PULSE WIDTH, Dn TO LE SETUP AND HOLD TIMES (f=1MHz; 50% duty cycle)

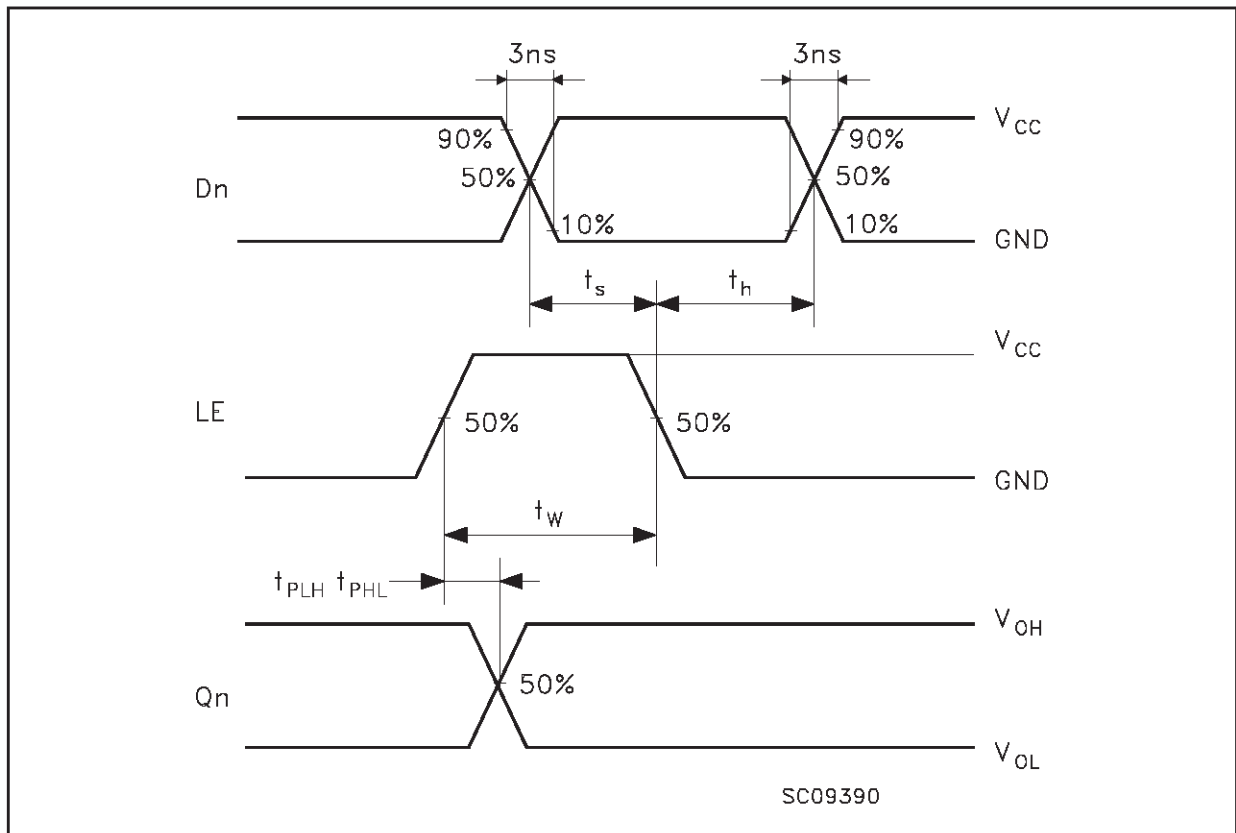

WAVEFORM 2: OUTPUT ENABLE AND DISABLE TIMES (f=1MHz; 50% duty cycle)

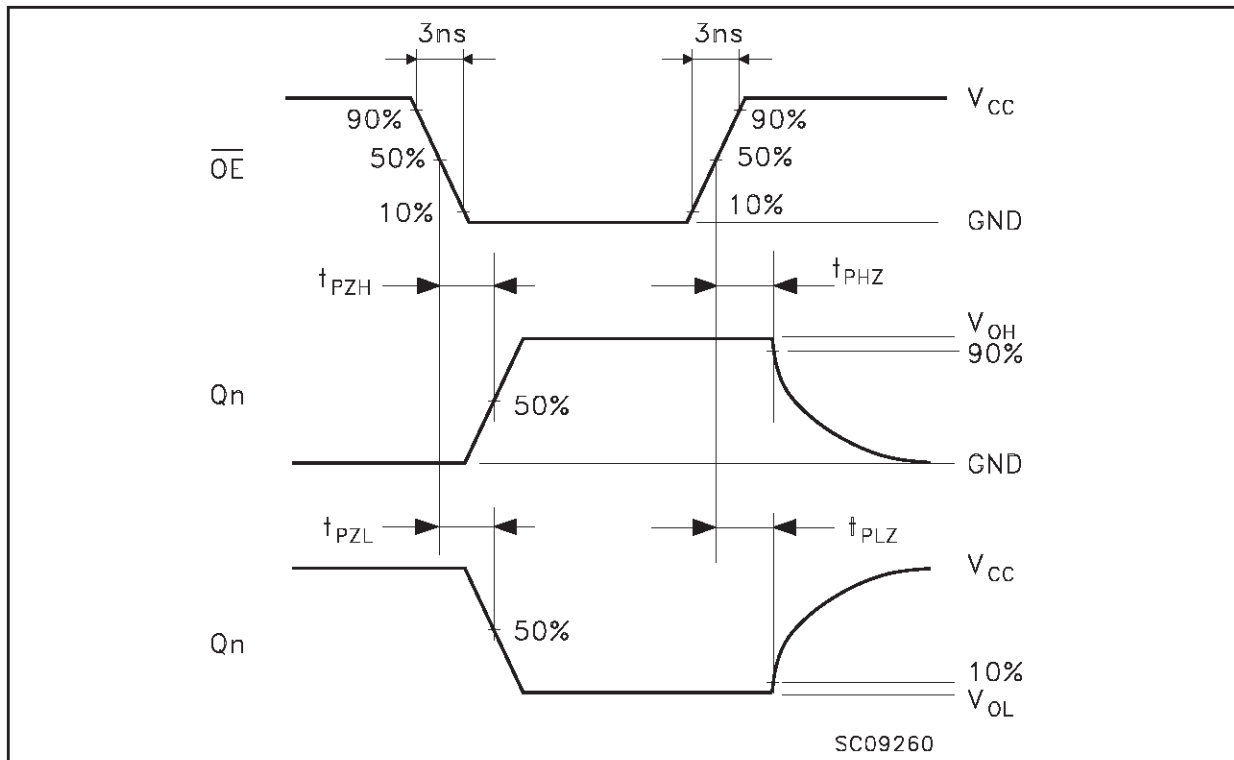

WAVEFORM 3: PROPAGATION DELAY TIME (f=1MHz; 50% duty cycle)

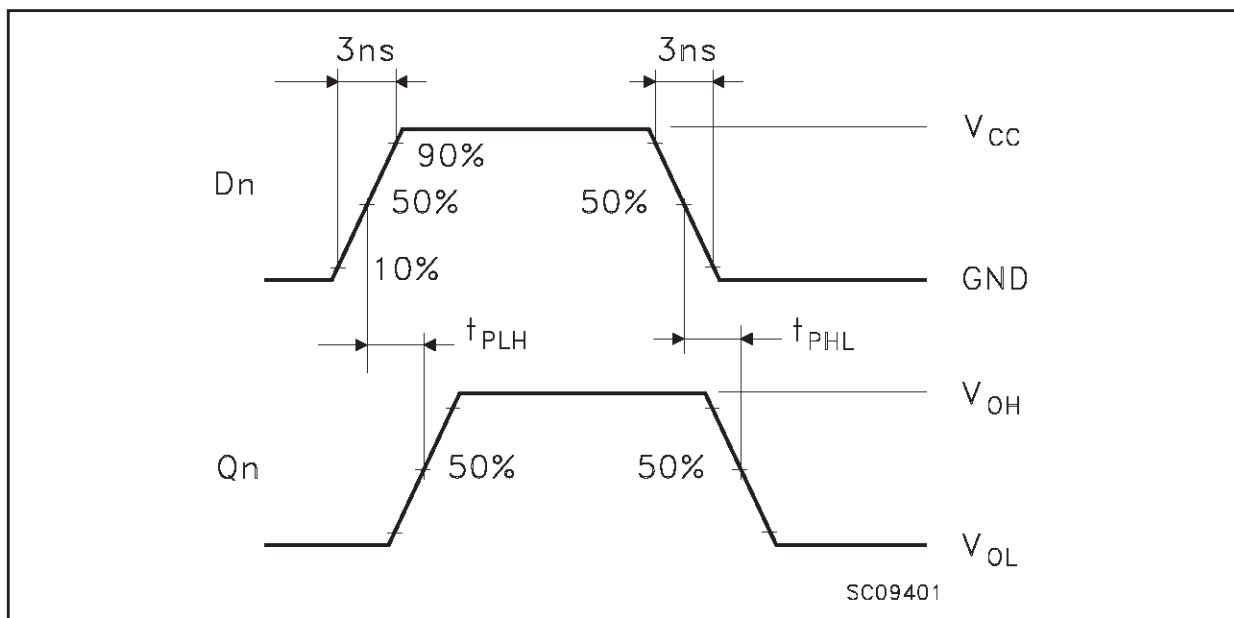

Ceramic DIP-20 MECHANICAL DATA

DIM.	mm			inch		
	MIN.	TYP.	MAX.	MIN.	TYP.	MAX.
A			25			0.984
B			7.8			0.307
D		3.3			0.130	
E	0.5		1.78	0.020		0.070
e3		22.86			0.900	
F	2.29		2.79	0.090		0.110
G	0.4		0.55	0.016		0.022
I	1.27		1.52	0.050		0.060
L	0.22		0.31	0.009		0.012
M	0.51		1.27	0.020		0.050
N1	4 (min.), 15 (max.)					
P	7.9		8.13	0.311		0.320
Q			5.71			0.225

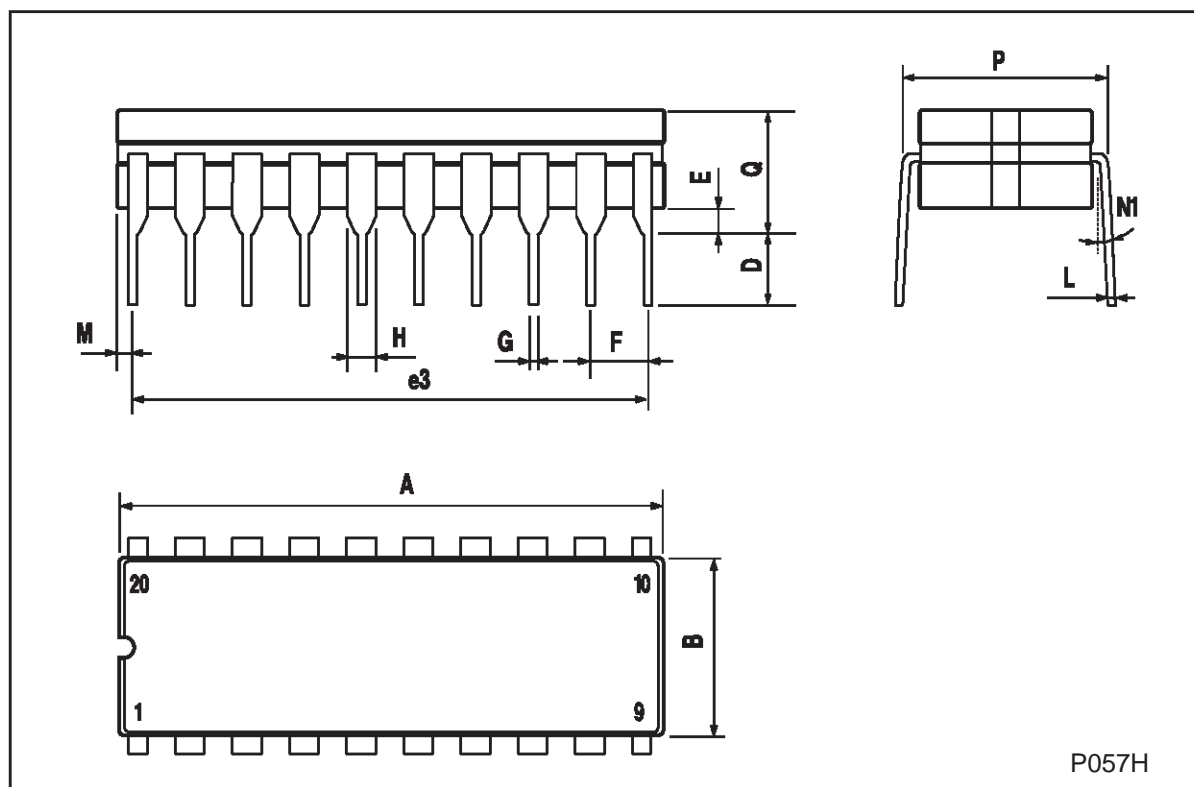

SO-20 MECHANICAL DATA

DIM.	mm			inch		
	MIN.	TYP.	MAX.	MIN.	TYP.	MAX.
A			2.65			0.104
a1	0.10		0.20	0.004		0.007
a2			2.45			0.096
b	0.35		0.49	0.013		0.019
b1	0.23		0.32	0.009		0.012
C		0.50			0.020	
c1	45 (typ.)					
D	12.60		13.00	0.496		0.512
E	10.00		10.65	0.393		0.419
e		1.27			0.050	
e3		11.43			0.450	
F	7.40		7.60	0.291		0.299
L	0.50		1.27	0.19		0.050
M			0.75			0.029
S	8 (max.)					

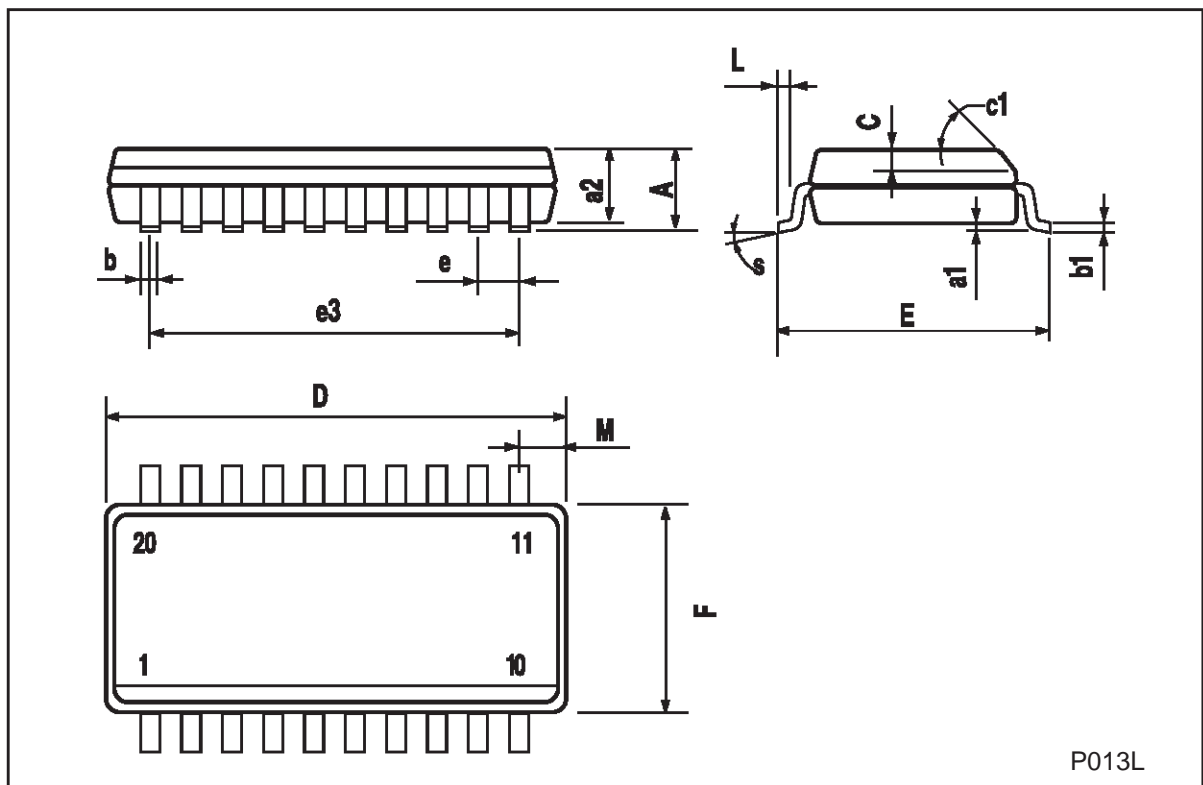

TSSOP20 MECHANICAL DATA

DIM.	mm			inch		
	MIN.	TYP.	MAX.	MIN.	TYP.	MAX.
A			1.1			0.433
A1	0.05	0.10	0.15	0.002	0.004	0.006
A2	0.85	0.9	0.95	0.335	0.354	0.374
b	0.19		0.30	0.0075		0.0118
c	0.09		0.2	0.0035		0.0079
D	6.4	6.5	6.6	0.252	0.256	0.260
E	6.25	6.4	6.5	0.246	0.252	0.256
E1	4.3	4.4	4.48	0.169	0.173	0.176
e		0.65 BSC			0.0256 BSC	
K	0°	4°	8°	0°	4°	8°
L	0.50	0.60	0.70	0.020	0.024	0.028

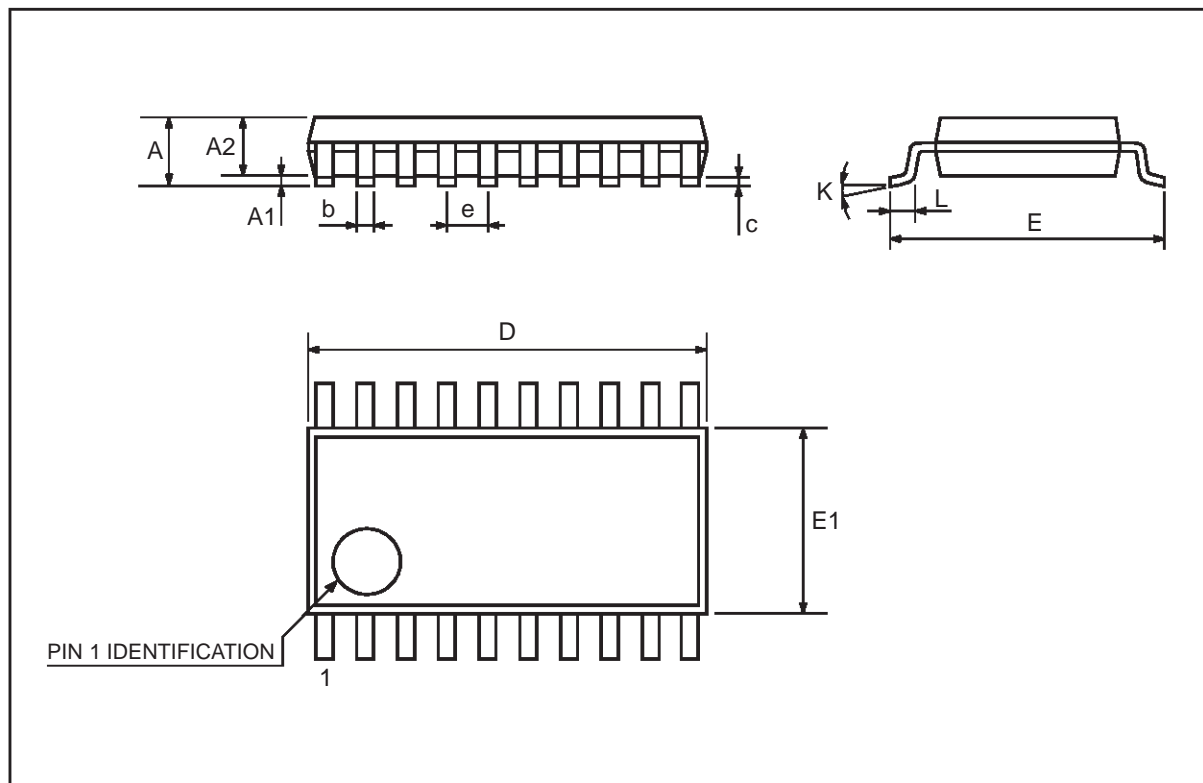

Information furnished is believed to be accurate and reliable. However, STMicroelectronics assumes no responsibility for the consequences of use of such information nor for any infringement of patents or other rights of third parties which may result from its use. No license is granted by implication or otherwise under any patent or patent rights of STMicroelectronics. Specifications mentioned in this publication are subject to change without notice. This publication supersedes and replaces all information previously supplied. STMicroelectronics products are not authorized for use as critical components in life support devices or systems without express written approval of STMicroelectronics.

© The ST logo is a registered trademark of STMicroelectronics

© 2001 STMicroelectronics - Printed in Italy - All Rights Reserved
STMicroelectronics GROUP OF COMPANIES

Australia - Brazil - China - Finland - France - Germany - Hong Kong - India - Italy - Japan - Malaysia - Malta - Morocco
Singapore - Spain - Sweden - Switzerland - United Kingdom

© <http://www.st.com>

