

SINGLE 2-INPUT NAND GATE

- 5V TOLERANT INPUTS
- HIGH SPEED: $t_{PD} = 4.7\text{ns}$ (MAX.) at $V_{CC} = 3\text{V}$
- LOW POWER DISSIPATION:
 $I_{CC} = 1\mu\text{A}$ (MAX.) at $T_A = 25^\circ\text{C}$
- POWER DOWN PROTECTION ON INPUTS AND OUTPUTS
- SYMMETRICAL OUTPUT IMPEDANCE:
 $|I_{OH}| = I_{OL} = 24\text{mA}$ (MIN) at $V_{CC} = 3\text{V}$
- BALANCED PROPAGATION DELAYS:
 $t_{PLH} \cong t_{PHL}$
- OPERATING VOLTAGE RANGE:
 $V_{CC}(\text{OPR}) = 1.65\text{V}$ to 5.5V
(1.2V Data Retention)
- IMPROVED LATCH-UP IMMUNITY

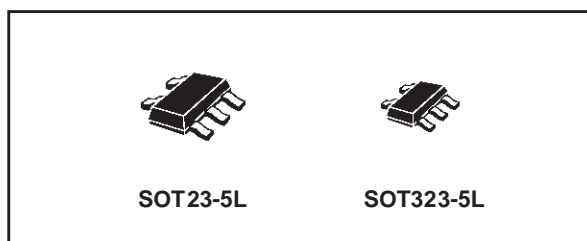

ORDER CODES

PACKAGE	T & R
SOT23-5L	74LX1G00STR
SOT323-5L	74LX1G00CTR

DESCRIPTION

The 74LX1G00 is a low voltage CMOS SINGLE 2-INPUT NAND GATE fabricated with sub-micron silicon gate and double-layer metal wiring C²MOS technology.

The internal circuit is composed of 3 stages including buffer output, which provide high noise immunity and stable output.

Power down protection is provided on all inputs and 0 to 7V can be accepted on inputs with no regard to the supply voltage. This device can be used to interface 5V to 3V.

All inputs and outputs are equipped with protection circuits against static discharge.

PIN CONNECTION AND IEC LOGIC SYMBOLS

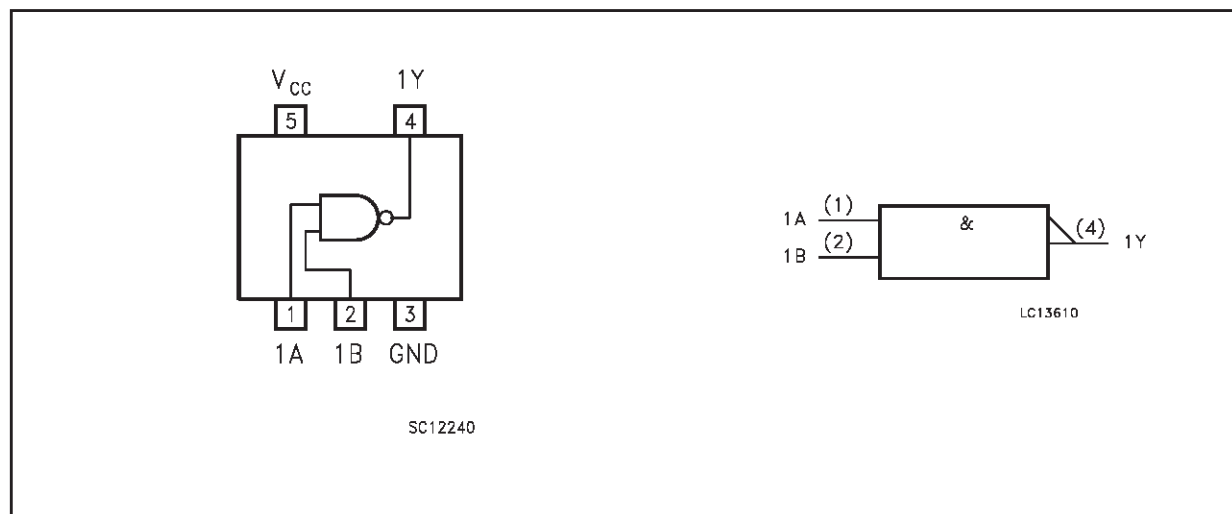

74LX1G00

INPUT EQUIVALENT CIRCUIT

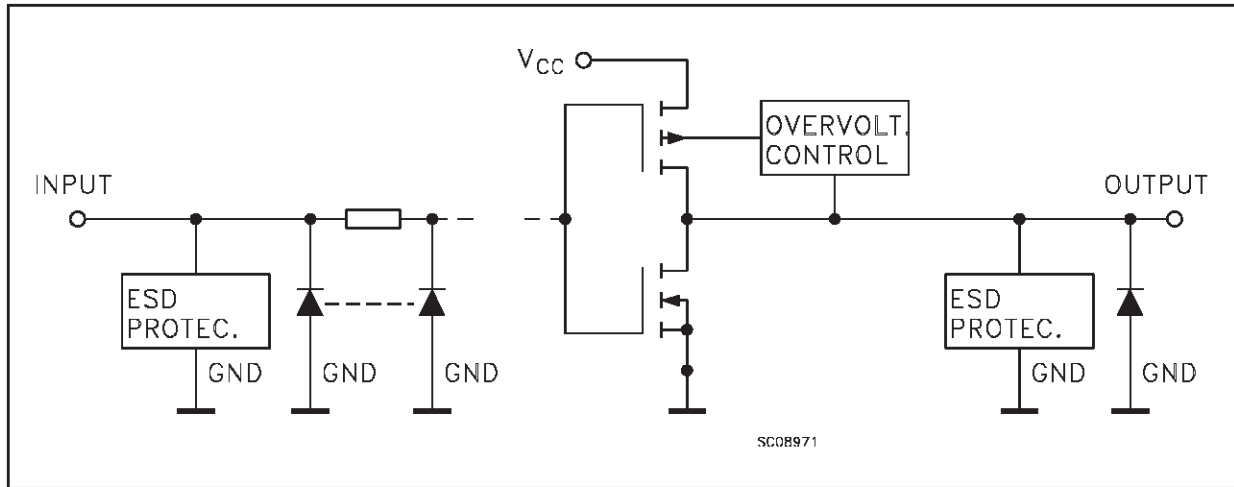

PIN DESCRIPTION

PIN No	SYMBOL	NAME AND FUNCTION
1	1A	Data Input
2	1B	Data Input
4	1Y	Data Output
3	GND	Ground (0V)
5	V _{CC}	Positive Supply Voltage

TRUTH TABLE

A	B	Y
L	L	H
L	H	H
H	L	H
H	H	L

ABSOLUTE MAXIMUM RATINGS

Symbol	Parameter	Value	Unit
V _{CC}	Supply Voltage	-0.5 to +7.0	V
V _I	DC Input Voltage	-0.5 to +7.0	V
V _O	DC Output Voltage (V _{CC} = 0V)	-0.5 to +7.0	V
V _O	DC Output Voltage (High or Low State) (note 1)	-0.5 to V _{CC} + 0.5	V
I _{IK}	DC Input Diode Current	- 50	mA
I _{OK}	DC Output Diode Current (note 2)	- 50	mA
I _O	DC Output Current	± 50	mA
I _{CC} or I _{GND}	DC V _{CC} or Ground Current per Supply Pin	± 50	mA
T _{stg}	Storage Temperature	-65 to +150	°C
T _L	Lead Temperature (10 sec)	300	°C

Absolute Maximum Ratings are those values beyond which damage to the device may occur. Functional operation under these conditions is not implied

1) I_O absolute maximum rating must be observed

2) V_O < GND, V_O > V_{CC}

RECOMMENDED OPERATING CONDITIONS

Symbol	Parameter	Value	Unit
V_{CC}	Supply Voltage (note 1)	1.65 to 5.5	V
V_I	Input Voltage	0 to 5.5	V
V_O	Output Voltage ($V_{CC} = 0V$)	0 to 5.5	V
V_O	Output Voltage (High or Low State)	0 to V_{CC}	V
I_{OH}, I_{OL}	High or Low Level Output Current ($V_{CC} = 4.5$ to $5.5V$)	± 32	mA
I_{OH}, I_{OL}	High or Low Level Output Current ($V_{CC} = 3.0$ to $3.6V$)	± 24	mA
I_{OH}, I_{OL}	High or Low Level Output Current ($V_{CC} = 2.7$ to $3.0V$)	± 12	mA
I_{OH}, I_{OL}	High or Low Level Output Current ($V_{CC} = 2.3$ to $2.7V$)	± 8	mA
I_{OH}, I_{OL}	High or Low Level Output Current ($V_{CC} = 1.65$ to $2.3V$)	± 4	mA
T_{op}	Operating Temperature	-55 to 125	$^{\circ}C$
dt/dv	Input Rise and Fall Time (note 2)	0 to 10	ns/V

1) Truth Table guaranteed: 1.2V to 3.6V

2) V_{IN} from 0.8V to 2V at $V_{CC} = 3.0V$

DC SPECIFICATION

Symbol	Parameter	Test Condition		Value				Unit
		V_{CC} (V)		-40 to 85 $^{\circ}C$		-55 to 125 $^{\circ}C$		
				Min.	Max.	Min.	Max.	
V_{IH}	High Level Input Voltage	1.65 to 1.95		$0.75V_{CC}$		$0.75V_{CC}$		V
		2.3 to 2.7		$0.7V_{CC}$		$0.7V_{CC}$		
		3.0 to 5.5		$0.7V_{CC}$		$0.7V_{CC}$		
V_{IL}	Low Level Input Voltage	1.65 to 1.95			$0.25V_{CC}$		$0.25V_{CC}$	V
		2.3 to 2.7			$0.3V_{CC}$		$0.3V_{CC}$	
		3.0 to 5.5			$0.3V_{CC}$		$0.3V_{CC}$	
V_{OH}	High Level Output Voltage	1.65 to 4.5	$I_O = -100 \mu A$	$V_{CC} - 0.1$		$V_{CC} - 0.1$		V
		1.65	$I_O = -4 \text{ mA}$	1.2		1.9		
		2.3	$I_O = -8 \text{ mA}$	1.9		2.2		
		3.0	$I_O = -16 \text{ mA}$	2.4		2.4		
			$I_O = -24 \text{ mA}$	2.2		2.2		
4.5	$I_O = -32 \text{ mA}$	3.8		3.8				
V_{OL}	Low Level Output Voltage	1.65 to 4.5	$I_O = 100 \mu A$		0.1		0.1	V
		1.65	$I_O = 4 \text{ mA}$		0.45		0.45	
		2.3	$I_O = 8 \text{ mA}$		0.3		0.3	
		3.0	$I_O = 16 \text{ mA}$		0.4		0.4	
			$I_O = 24 \text{ mA}$		0.55		0.55	
4.5	$I_O = 32 \text{ mA}$		0.55		0.55			
I_I	Input Leakage Current	1.65 to 5.5	$V_I = 0$ to $5.5V$		± 10		± 10	μA
I_{off}	Power Off Leakage Current	0	V_I or $V_O = 5.5V$		10		10	μA
I_{CC}	Quiescent Supply Current	1.65 to 5.5	$V_I = V_{CC}$ or GND		10		10	μA

74LX1G00

AC ELECTRICAL CHARACTERISTICS (Input $t_r = t_f = 3\text{ns}$)

Symbol	Parameter	Test Condition				Value				Unit
		V_{CC} (V)	C_L (pF)	R_L (Ω)	$t_s = t_r$ (ns)	-40 to 85 °C		-55 to 125 °C		
						Min.	Max.	Min.	Max.	
t_{PLH} t_{PHL}	Propagation Delay Time	1.65 to 1.95	15	1M Ω	3.0	2	12.0	2	12.0	ns
		2.3 to 2.7				2	7.0	2	7.0	
		3.0 to 3.6				1	4.7	1	4.7	
		4.5 to 5.5				1	4.1	1	4.1	
		1.65 to 1.95	30	1000	2.0	2	13.0	2	13.0	
		2.3 to 2.7	30	500	2.0	2	7.5	2	7.5	
		2.7	50	500	2.5	1	5.6	1	5.6	
		3.0 to 3.6	50	500	2.5	1	5.2	1	5.2	
		4.5 to 5.5	50	500	2.5	1	4.5	1	4.5	

CAPACITIVE CHARACTERISTICS

Symbol	Parameter	Test Condition		Value			Unit
		V_{CC} (V)		$T_A = 25\text{ °C}$			
				Min.	Typ.	Max.	
C_{IN}	Input Capacitance	0			4		pF
C_{PD}	Power Dissipation Capacitance (note 1)	1.8	$f_{IN} = 10\text{MHz}$		16		pF
		2.5			18		
		3.3			20		

1) C_{PD} is defined as the value of the IC's internal equivalent capacitance which is calculated from the operating current consumption without load. (Refer to Test Circuit). Average operating current can be obtained by the following equation. $I_{CC(oper)} = C_{PD} \times V_{CC} \times f_{IN} + I_{CC}$

TEST CIRCUIT

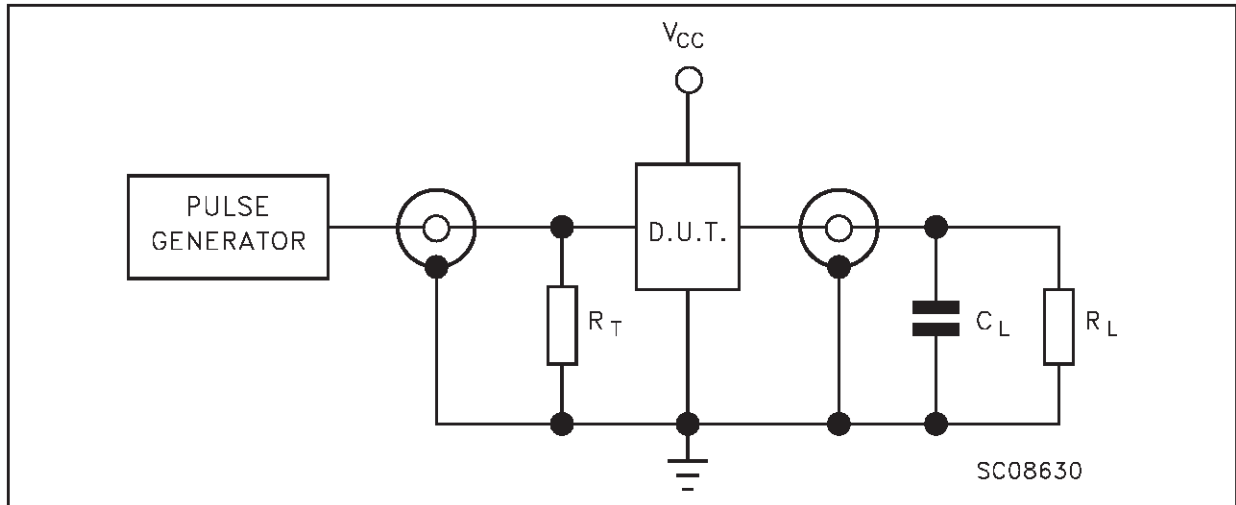

$R_T = Z_{OUT}$ of pulse generator (typically 50Ω)

TEST CIRCUIT AND WAVEFORM SYMBOL VALUE

Symbol	V_{CC}		
	1.65 to 1.95V	2.3 to 2.7V	2.7 to 5.5V
C_L	15pF/30pF	15pF/30pF	15pF/50pF
R_L	1MΩ/1000Ω	1MΩ/500Ω	1MΩ/500Ω
V_{IH}	V_{CC}	V_{CC}	V_{CC}
V_M	$V_{CC}/2$	$V_{CC}/2$	$V_{CC}/2$
$t_r = t_f$	<2.0ns	<2.0ns	<2.5ns

WAVEFORM: PROPAGATION DELAY (f=1MHz; 50% duty cycle)

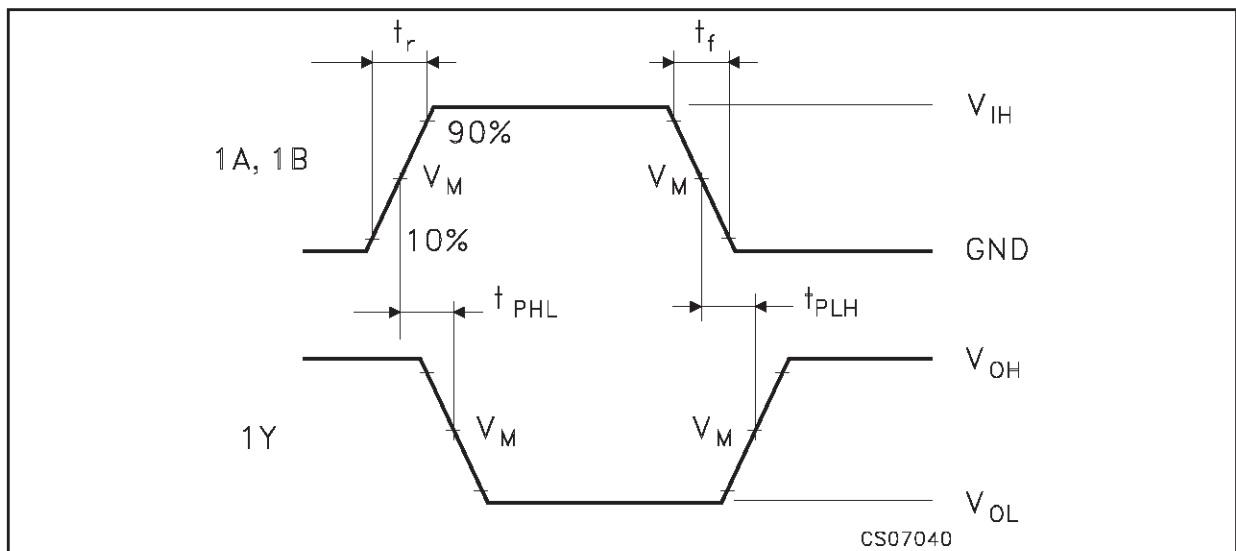

SOT23-5L MECHANICAL DATA

DIM.	mm.			mils		
	MIN.	TYP.	MAX.	MIN.	TYP.	MAX.
A	0.90		1.45	35.4		57.1
A1	0.00		0.15	0.0		5.9
A2	0.90		1.30	35.4		51.2
b	0.35		0.50	13.7		19.7
C	0.09		0.20	3.5		7.8
D	2.80		3.00	110.2		118.1
E	2.60		3.00	102.3		118.1
E1	1.50		1.75	59.0		68.8
e		0.95			37.4	
e1		1.9			74.8	
L	0.35		0.55	13.7		21.6

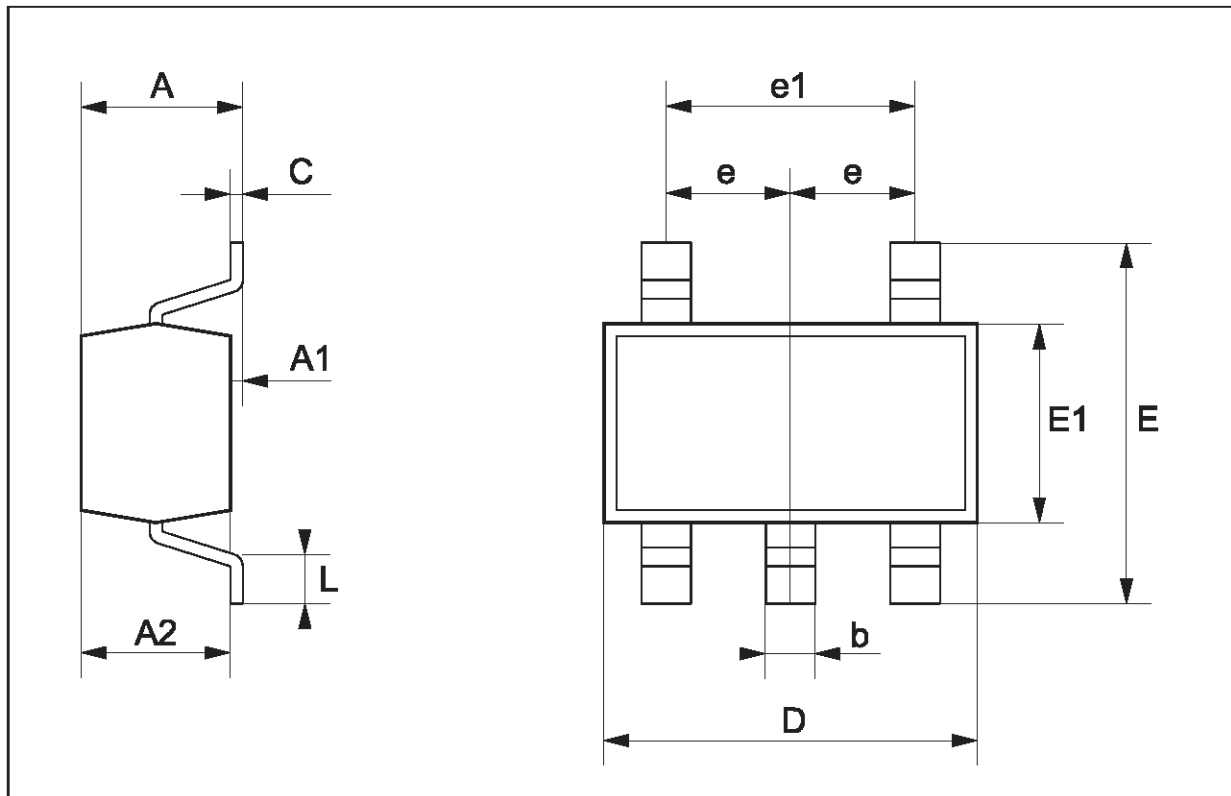

SOT323-5L MECHANICAL DATA

DIM.	mm.			mils		
	MIN.	TYP.	MAX.	MIN.	TYP.	MAX.
A	0.80		1.10	31.5		43.3
A1	0.00		0.10	0.0		3.9
A2	0.80		1.00	31.5		39.4
b	0.15		0.30	5.9		11.8
C	0.10		0.18	3.9		7.1
D	1.80		2.20	70.9		86.6
E	1.80		2.40	70.9		94.5
E1	1.15		1.35	45.3		53.1
e		0.65			25.6	
e1		1.3			51.2	
L	0.10		0.30	3.9		11.8

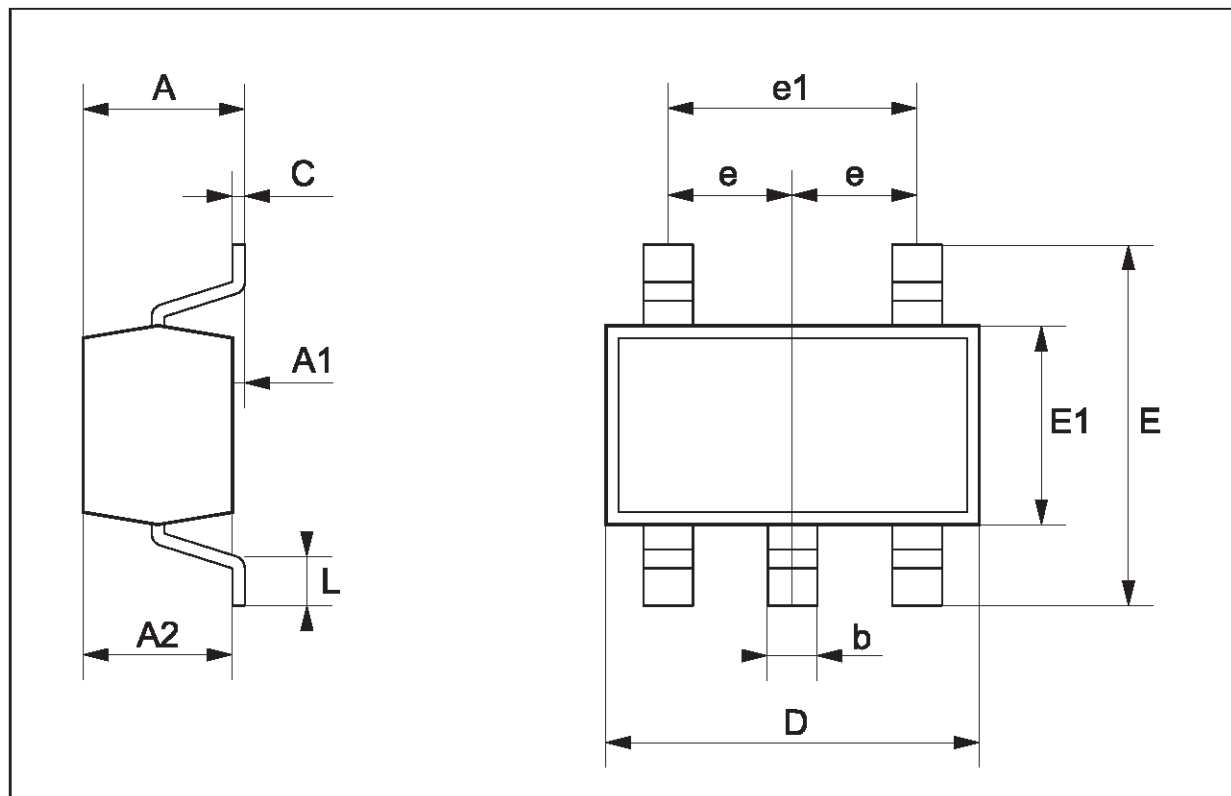

Tape & Reel SOT23-xL MECHANICAL DATA

DIM.	mm.			inch		
	MIN.	TYP	MAX.	MIN.	TYP.	MAX.
A			180			7.086
C	12.8	13.0	13.2	0.504	0.512	0.519
D	20.2			0.795		
N	60			2.362		
T			14.4			0.567
Ao	3.13	3.23	3.33	0.123	0.127	0.131
Bo	3.07	3.17	3.27	0.120	0.124	0.128
Ko	1.27	1.37	1.47	0.050	0.054	0.058
Po	3.9	4.0	4.1	0.153	0.157	0.161
P	3.9	4.0	4.1	0.153	0.157	0.161

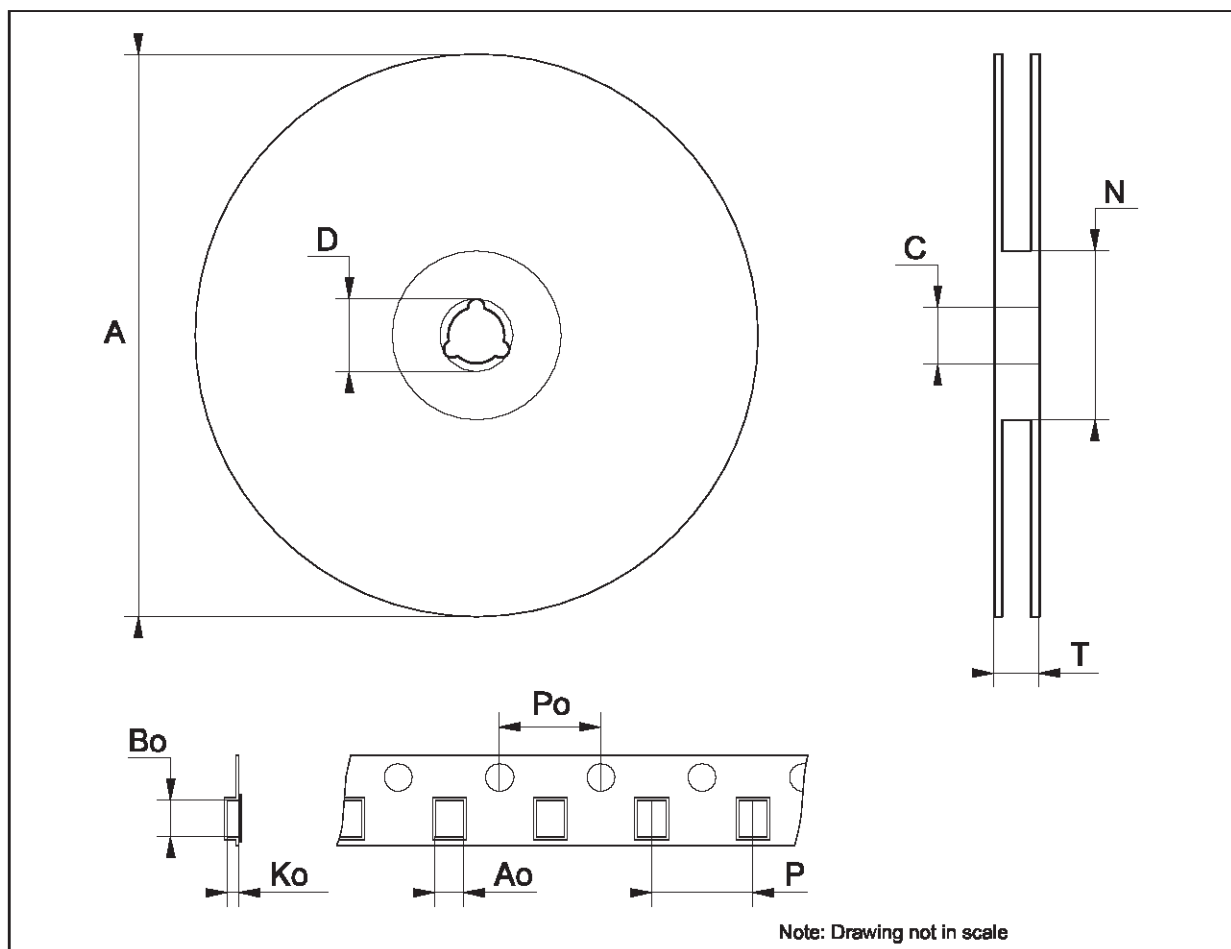

Tape & Reel SOT323-xL MECHANICAL DATA

DIM.	mm.			inch		
	MIN.	TYP	MAX.	MIN.	TYP.	MAX.
A	175	180	185	6.889	7.086	7.283
C	12.8	13	13.2	0.504	0.512	0.519
D	20.2			0.795		
N	59.5	60	60.5		2.362	
T			14.4			0.567
Ao		2.25			0.088	
Bo		2.7			0.106	
Ko		1.2			0.047	
Po	3.98	4	4.2	0.156	0.157	0.165
P	3.98	4	4.2	0.156	0.157	0.165

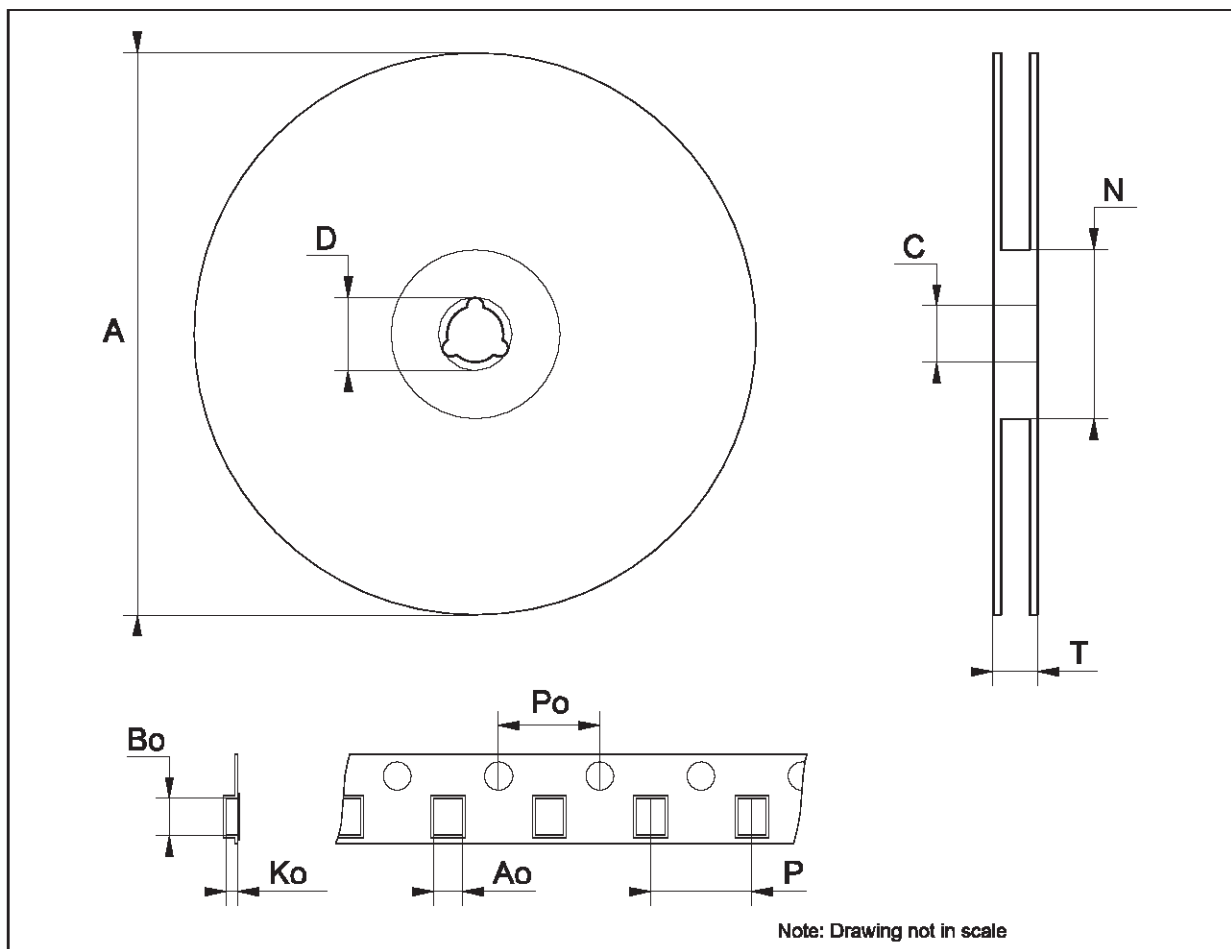

Information furnished is believed to be accurate and reliable. However, STMicroelectronics assumes no responsibility for the consequences of use of such information nor for any infringement of patents or other rights of third parties which may result from its use. No license is granted by implication or otherwise under any patent or patent rights of STMicroelectronics. Specifications mentioned in this publication are subject to change without notice. This publication supersedes and replaces all information previously supplied. STMicroelectronics products are not authorized for use as critical components in life support devices or systems without express written approval of STMicroelectronics.

© The ST logo is a registered trademark of STMicroelectronics

© 2002 STMicroelectronics - Printed in Italy - All Rights Reserved
STMicroelectronics GROUP OF COMPANIES

Australia - Brazil - Canada - China - Finland - France - Germany - Hong Kong - India - Israel - Italy - Japan - Malaysia - Malta - Morocco
Singapore - Spain - Sweden - Switzerland - United Kingdom - United States.

© <http://www.st.com>