



BUF410A

HIGH VOLTAGE FAST-SWITCHING NPN POWER TRANSISTOR

- STMicroelectronics PREFERRED SALESTYPE
- HIGH VOLTAGE CAPABILITY
- VERY HIGH SWITCHING SPEED
- MINIMUM LOT-TO-LOT SPREAD FOR RELIABLE OPERATION
- LOW BASE-DRIVE REQUIREMENTS

APPLICATIONS:

- SWITCH MODE POWER SUPPLIES
- MOTOR CONTROL

DESCRIPTION

The BUF410A is manufactured using High Voltage Multi Epitaxial Planar technology for high switching speeds and high voltage capacity. It uses a Cellular Emitter structure with planar edge termination to enhance switching speeds while maintaining a wide RBSOA.

The BUF series is designed for use in high-frequency power supplies and motor control applications.

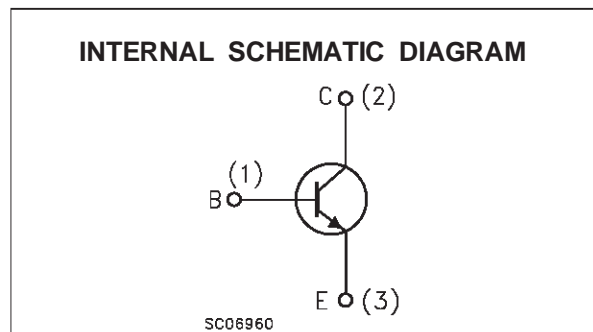
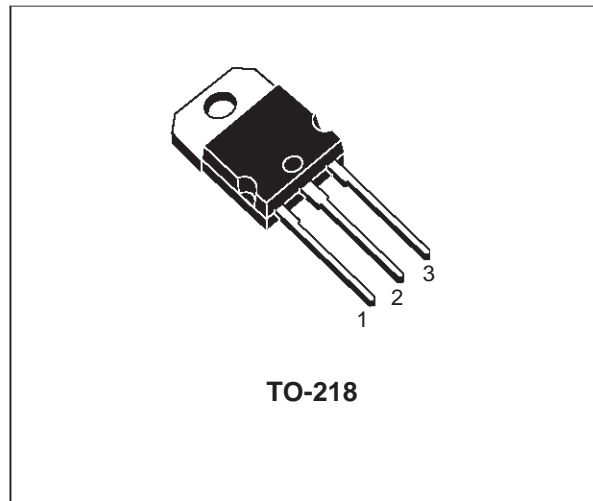

ABSOLUTE MAXIMUM RATINGS

Symbol	Parameter	Value	Unit
V_{CEV}	Collector-Emitter Voltage ($V_{BE} = -1.5\text{ V}$)	1000	V
V_{CEO}	Collector-Emitter Voltage ($I_B = 0$)	450	V
V_{EBO}	Emitter-Base Voltage ($I_C = 0$)	7	V
I_C	Collector Current	15	A
I_{CM}	Collector Peak Current ($t_p < 5\text{ ms}$)	30	A
I_B	Base Current	3	A
I_{BM}	Base Peak Current ($t_p < 5\text{ ms}$)	4.5	A
P_{tot}	Total Dissipation at $T_c = 25\text{ }^\circ\text{C}$	125	W
T_{stg}	Storage Temperature	-65 to 150	$^\circ\text{C}$
T_j	Max Operation Junction Temperature	150	$^\circ\text{C}$

BUF410A

THERMAL DATA

R _{thj-case}	Thermal Resistance Junction-Case	Max	1	°C/W
-----------------------	----------------------------------	-----	---	------

ELECTRICAL CHARACTERISTICS (T_{case} = 25 °C unless otherwise specified)

Symbol	Parameter	Test Conditions	Min.	Typ.	Max.	Unit
I _{CER}	Collector Cut-off Current (R _{BE} = 10 Ω)	V _{CE} = 1000 V V _{CE} = 1000 V T _C = 100 °C			0.2 1	mA mA
I _{CEV}	Collector Cut-off Current (V _{BE} = -1.5 V)	V _{CE} = 1000 V V _{CE} = 1000 V T _C = 100 °C			0.2 1	mA mA
I _{EBO}	Emitter Cut-off Current (I _C = 0)	V _{EB} = 5 V			1	mA
V _{CEO(sus)*}	Collector-Emitter Sustaining Voltage (I _B = 0)	I _C = 200 mA L = 25 mH	450			V
V _{EBO}	Emitter Base Voltage (I _C = 0)	I _E = 50 mA	7			V
V _{CE(sat)*}	Collector-Emitter Saturation Voltage	I _C = 5 A I _B = 0.5 A I _C = 5 A I _B = 0.5 A T _C = 100°C I _C = 10 A I _B = 2 A I _C = 10 A I _B = 2 A T _C = 100°C		0.8 0.5	2.8 2	V V V
V _{BE(sat)*}	Base-Emitter Saturation Voltage	I _C = 5 A I _B = 0.5 A I _C = 5 A I _B = 0.5 A T _C = 100°C I _C = 10 A I _B = 2 A I _C = 10 A I _B = 2 A T _C = 100°C		0.9 1.1	1.5 1.5	V V V V
di _c /dt	Rate of rise on-state Collector Current	V _{CC} = 300 V R _C = 0 t _p = 3 μs I _{B1} = 0.75 A T _C = 25°C I _{B1} = 0.75 A T _C = 100°C I _{B1} = 3 A T _C = 100°C	45 100	60		A/μs A/μs A/μs
V _{CE(3μs)}	Collector-Emitter Dynamic Voltage	V _{CC} = 300 V R _C = 60 Ω I _{B1} = 0.75 A T _C = 25°C I _{B1} = 0.75 A T _C = 100°C		2.1	8	V V
V _{CE(5μs)}	Collector-Emitter Dynamic Voltage	V _{CC} = 300 V R _C = 60 Ω I _{B1} = 0.75 A T _C = 25°C I _{B1} = 0.75 A T _C = 100°C		1.1	4	V V
t _s t _f t _c	INDUCTIVE LOAD Storage Time Fall Time Cross Over Time	I _C = 5 A V _{CC} = 50 V V _{BB} = -5 V R _{BB} = 1.2 Ω V _{clamp} = 400 V I _{B1} = 0.5 A L = 0.5 mH		0.8 0.05 0.08		μs μs μs
t _s t _f t _c	INDUCTIVE LOAD Storage Time Fall Time Cross Over Time	I _C = 5 A V _{CC} = 50 V V _{BB} = -5 V R _{BB} = 1.2 Ω V _{clamp} = 400 V I _{B1} = 0.5 A L = 0.5 mH T _C = 100°C			1.8 0.1 0.18	μs μs μs
V _{CEW}	Maximum Collector Emitter Voltage without Snubber	I _C = 5 A V _{CC} = 50 V V _{BB} = -5 V R _{BB} = 1.2 Ω I _{B1} = 0.5 A L = 0.5 mH T _C = 125°C	500			V
t _s t _f t _c	INDUCTIVE LOAD Storage Time Fall Time Cross Over Time	I _C = 5 A V _{CC} = 50 V V _{BB} = 0 R _{BB} = 0.3 Ω V _{clamp} = 400 V I _{B1} = 0.5 A L = 0.5 mH		1.5 0.04 0.07		μs μs μs

ELECTRICAL CHARACTERISTICS (continued)

Symbol	Parameter	Test Conditions		Min.	Typ.	Max.	Unit
t_s t_f t_c	INDUCTIVE LOAD Storage Time Fall Time Cross Over Time	$I_C = 5\text{ A}$ $V_{BB} = 0$ $V_{clamp} = 400\text{ V}$ $L = 0.5\text{ mH}$	$V_{CC} = 50\text{ V}$ $R_{BB} = 0.3\ \Omega$ $I_{B1} = 0.5\text{ A}$ $T_C = 100^\circ\text{C}$			3 0.15 0.25	μs μs μs
V_{CEW}	Maximum Collector Emitter Voltage without Snubber	$I_C = 5\text{ A}$ $V_{BB} = 0$ $I_{B1} = 0.5\text{ A}$ $T_C = 125^\circ\text{C}$	$V_{CC} = 50\text{ V}$ $R_{BB} = 0.3\ \Omega$ $L = 0.5\text{ mH}$	500			V
t_s t_f t_c	INDUCTIVE LOAD Storage Time Fall Time Cross Over Time	$I_C = 10\text{ A}$ $V_{BB} = -5\text{ V}$ $V_{clamp} = 400\text{ V}$ $L = 0.25\text{ mH}$	$V_{CC} = 50\text{ V}$ $R_{BB} = 1.2\ \Omega$ $I_{B1} = 2\text{ A}$		1.9 0.06 0.12		μs μs μs
t_s t_f t_c	INDUCTIVE LOAD Storage Time Fall Time Cross Over Time	$I_C = 10\text{ A}$ $V_{BB} = -5\text{ V}$ $V_{clamp} = 400\text{ V}$ $L = 0.25\text{ mH}$	$V_{CC} = 50\text{ V}$ $R_{BB} = 1.2\ \Omega$ $I_{B1} = 2\text{ A}$ $T_C = 100^\circ\text{C}$			3.2 0.12 0.3	μs μs μs
V_{CEW}	Maximum Collector Emitter Voltage without Snubber	$I_{C\text{Woff}} = 15\text{ A}$ $V_{BB} = -5\text{ V}$ $L = 0.1\text{ mH}$ $T_C = 125^\circ\text{C}$	$V_{CC} = 50\text{ V}$ $R_{BB} = 1.2\ \Omega$ $I_{B1} = 3\text{ A}$	400			V

Inductive Load Switching Test Circuit

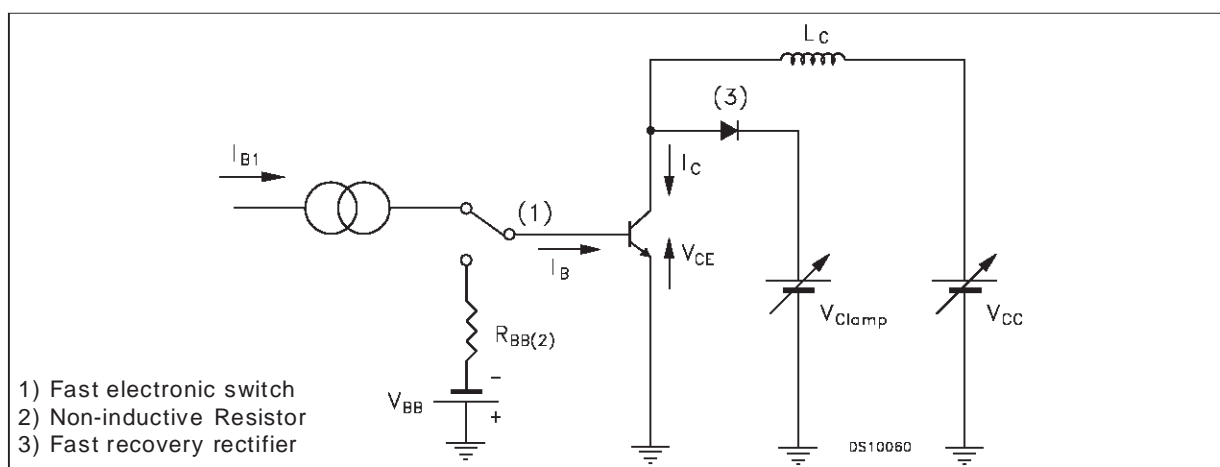

BUF410A

Turn-on Switching Test Waveforms.

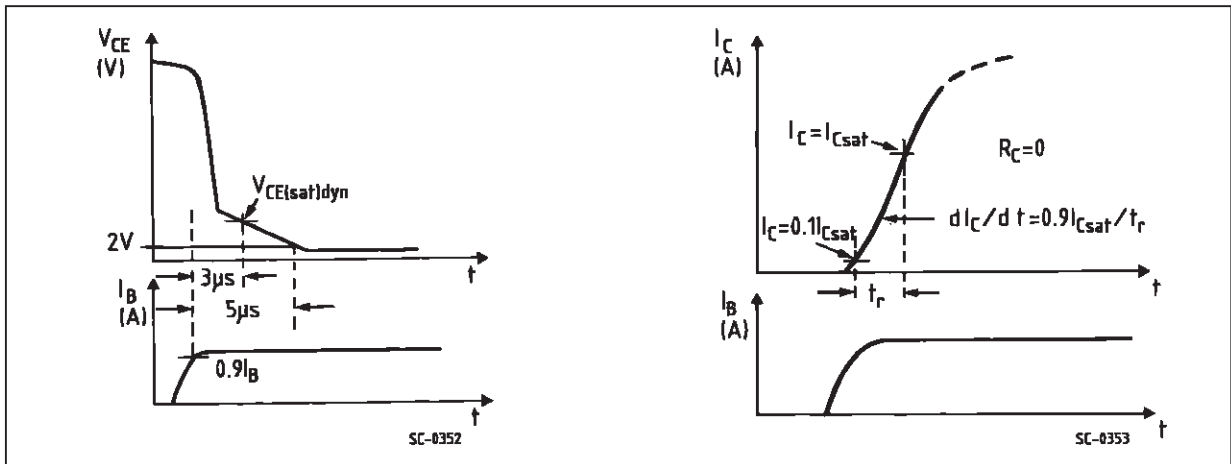

Turn-off Switching Test Waveforms (inductive load).

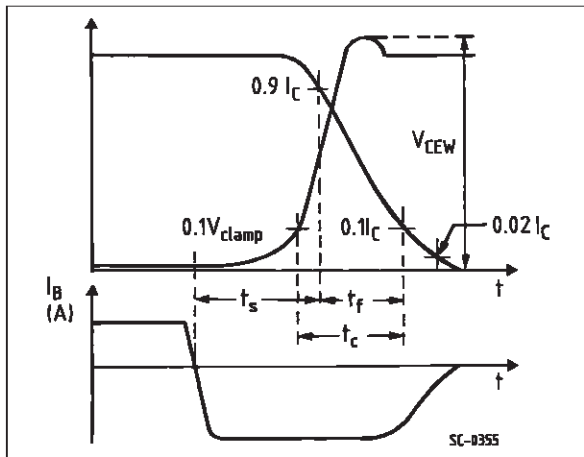

Forward Biased Safe Operating Areas.

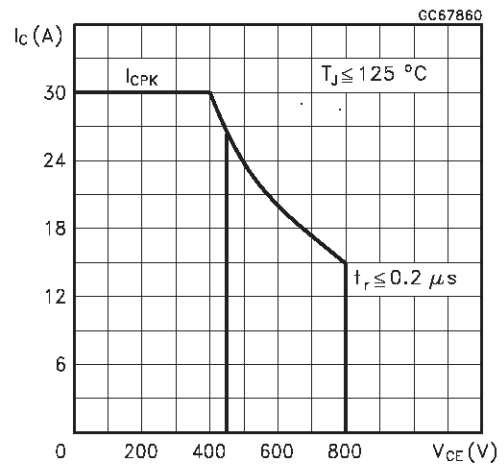

Reverse Biased Safe Operating Area

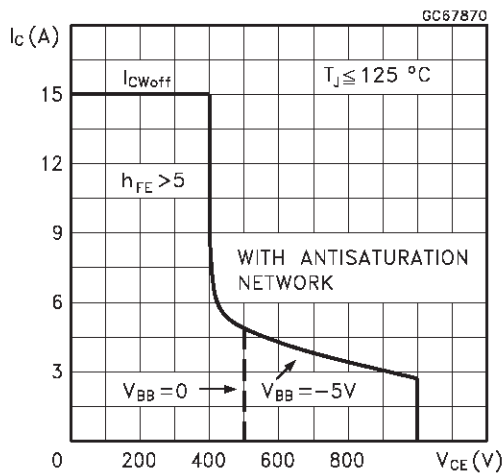

Storage Time Versus Pulse Time.

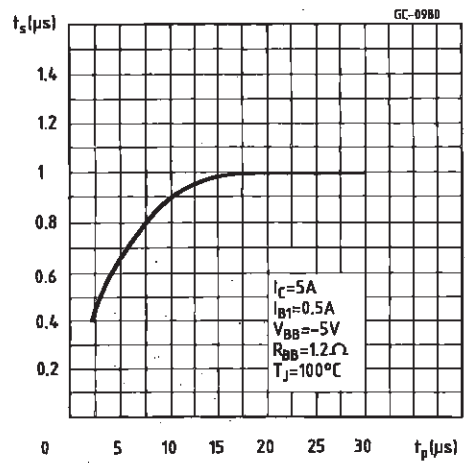

TO-218 (SOT-93) MECHANICAL DATA

DIM.	mm			inch		
	MIN.	TYP.	MAX.	MIN.	TYP.	MAX.
A	4.7		4.9	0.185		0.193
C	1.17		1.37	0.046		0.054
D		2.5			0.098	
E	0.5		0.78	0.019		0.030
F	1.1		1.3	0.043		0.051
G	10.8		11.1	0.425		0.437
H	14.7		15.2	0.578		0.598
L2	-		16.2	-		0.637
L3		18			0.708	
L5	3.95		4.15	0.155		0.163
L6		31			1.220	
R	-		12.2	-		0.480
Ø	4		4.1	0.157		0.161

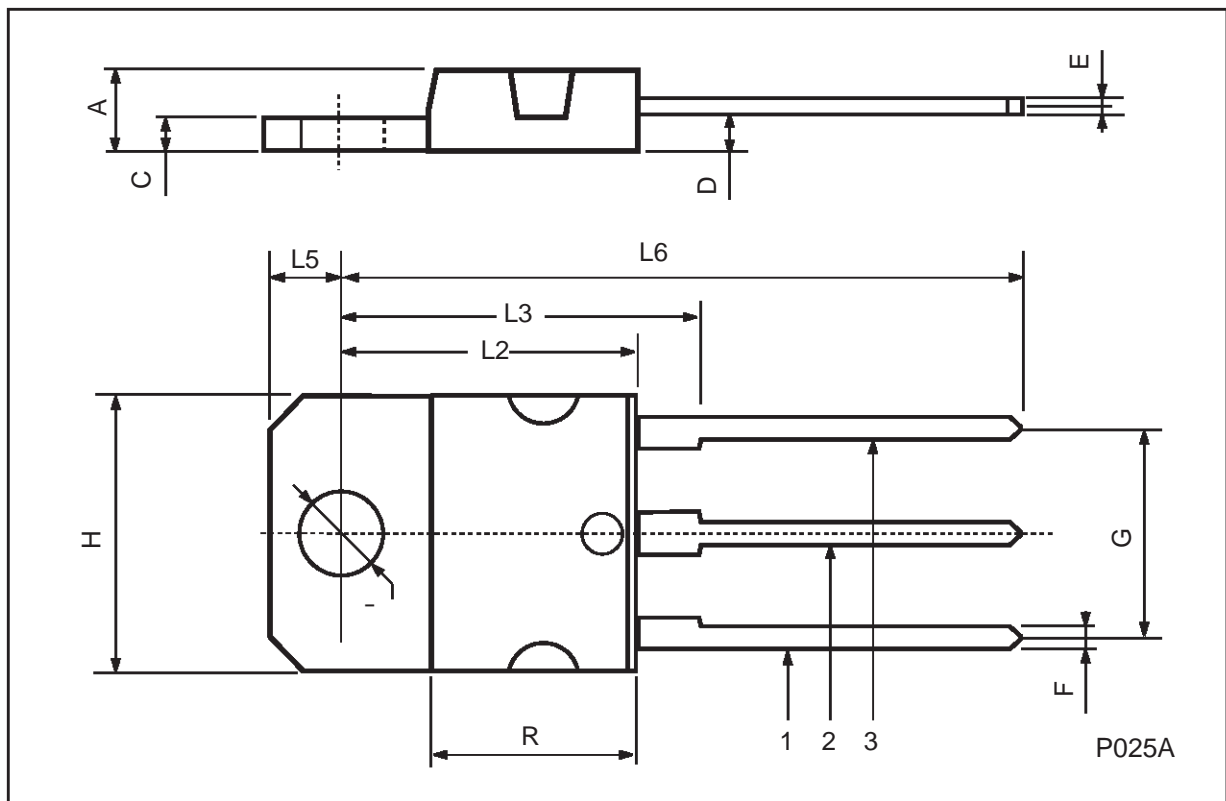

Information furnished is believed to be accurate and reliable. However, STMicroelectronics assumes no responsibility for the consequences of use of such information nor for any infringement of patents or other rights of third parties which may result from its use. No license is granted by implication or otherwise under any patent or patent rights of STMicroelectronics. Specification mentioned in this publication are subject to change without notice. This publication supersedes and replaces all information previously supplied. STMicroelectronics products are not authorized for use as critical components in life support devices or systems without express written approval of STMicroelectronics.

The ST logo is a trademark of STMicroelectronics

© 2002 STMicroelectronics – Printed in Italy – All Rights Reserved

STMicroelectronics GROUP OF COMPANIES

Australia - Brazil - Canada - China - Finland - France - Germany - Hong Kong - India - Israel - Italy - Japan - Malaysia - Malta - Morocco - Singapore - Spain - Sweden - Switzerland - United Kingdom - United States.

<http://www.st.com>