



### FEATURES

- Dedicated thyristor structure for capacitance discharge ignition operation
- High pulse current capability  
190A @  $t_p = 10\mu s$
- Fast turn-on operation
- Designed for high ambient temperature (up to 120°C)

### BENEFITS

- Space saving thanks to monolithic function integration
- High reliability with planar technology

### DESCRIPTION

The FLC01 series has been especially developed for capacitance discharge operation. The main applications are gas lighters or ignitors such as cookers / gas boilers / gas hobs...

Based on ST's ASD<sup>TM</sup> technology, it provides a fully integrated function, with high performance and reliability levels, adapted to severe and hot temperature environment.

**Th:** Thyristor for switching operation.

**Z:** Zener diode to set the threshold voltage.

**D:** Diode for reverse conduction.

**R:** 2 kΩ resistor.

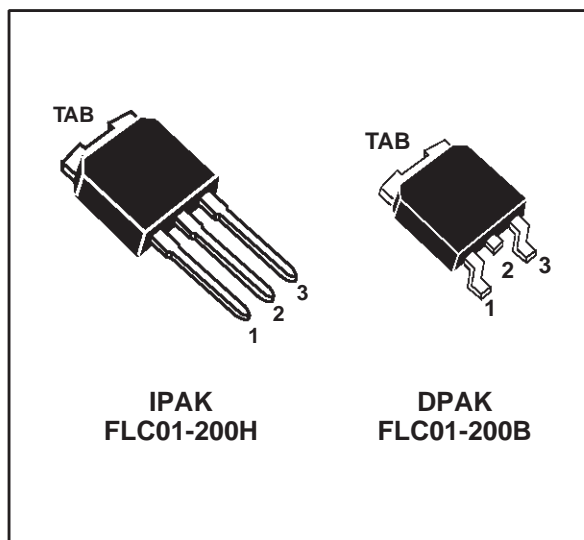

### FUNCTIONAL DIAGRAM

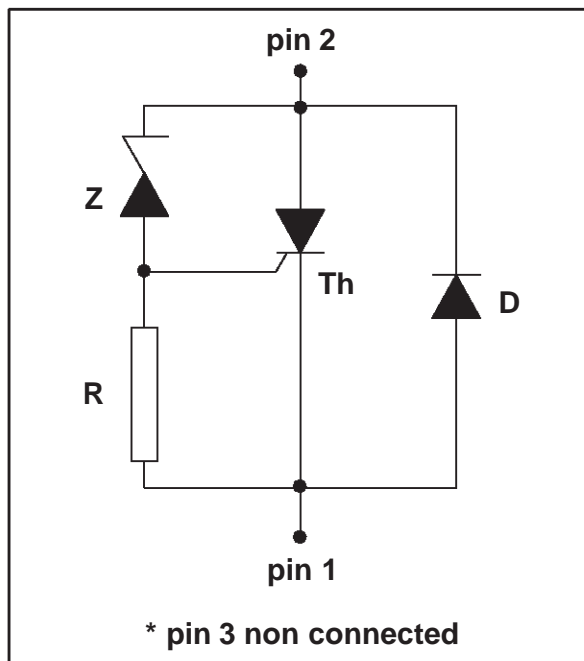

# FLC01-200x

## ABSOLUTE RATINGS (limiting values)

Symbol	Parameter	Value	Unit
$I_{TRM}$	Repetitive surge peak on state current for thyristor $-30^{\circ}\text{C} \leq T_{amb} \leq 120^{\circ}\text{C}$	190	A
$I_{FRM}$	Repetitive surge peak on state current for diode $-30^{\circ}\text{C} \leq T_{amb} \leq 120^{\circ}\text{C}$		
$di/dt$	Critical rate of rise time on state current $-30^{\circ}\text{C} \leq T_{amb} \leq 120^{\circ}\text{C}$	120	A/ $\mu\text{s}$
$T_{stg}$ $T_j$	Storage junction temperature range Maximum junction temperature	- 40 to + 150 + 125	$^{\circ}\text{C}$
$T_{oper}$	Operating temperature range	-30 + 120	$^{\circ}\text{C}$
$T_L$	Maximum lead temperature for soldering during 10s	260	$^{\circ}\text{C}$

Note 1 : Test current waveform

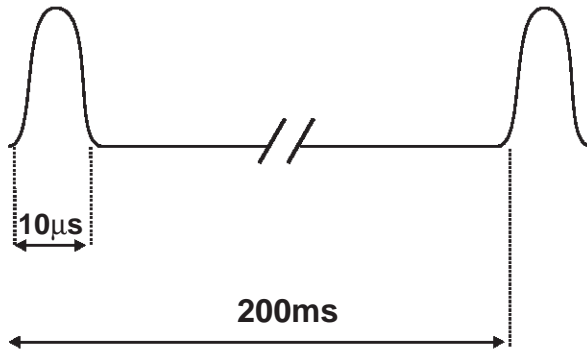

## THERMAL RESISTANCE

Symbol	Parameter	Value	Unit
$R_{th(j-a)}$	Thermal resistance junction to ambient	100	$^{\circ}\text{C}/\text{W}$

## ORDERING INFORMATION

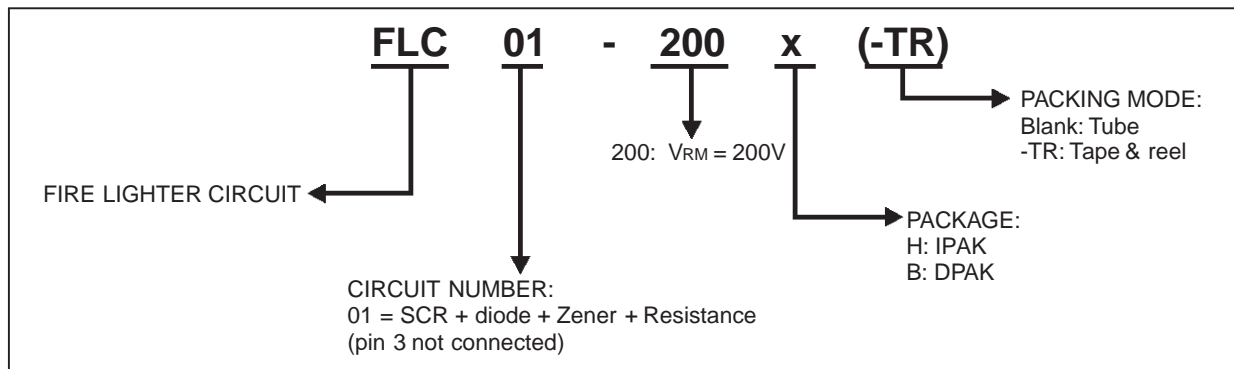

**ELECTRICAL CHARACTERISTICS**

Symbol	Parameters
$V_{RM}$	Stand-off voltage
$V_{BO}$	Breakover voltage
$V_T$	On-state voltage
$V_F$	Diode forward voltage drop
$I_{BO}$	Breakover current
$I_{RM}$	Leakage current
$\alpha T$	Temperature coefficient for $V_{BO}$

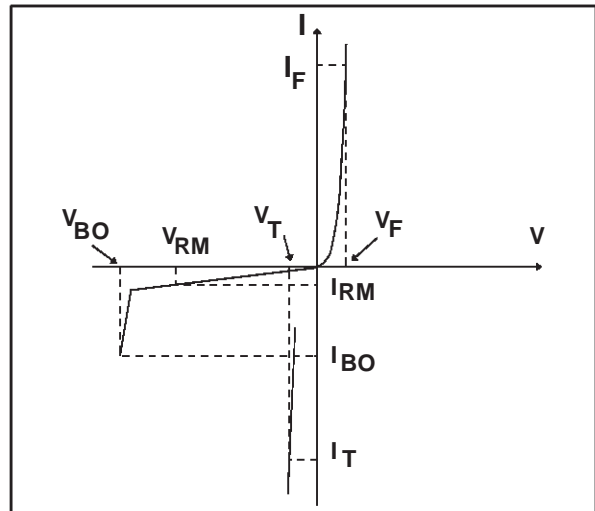

**DIODE (D) PARAMETER**

Symbol	Test Conditions			Value	Unit	
$V_F$	$I_F = 2A$	$t_p \leq 500\mu s$	$T_j = 25^\circ C$	Max.	1.7	V

**THYRISTOR (Th) and ZENER (Z) PARAMETERS**

Symbol	Test conditions	Min.	Typ.	Max.	Unit	
$I_{RM}$	$V_{RM} = 200 V$	$T_j = 25^\circ C$		1	$\mu A$	
		$T_j = 125^\circ C$		10	$\mu A$	
$V_{BO}$	at $I_{BO}$	$T_j = 25^\circ C$	206	220	233	V
$I_{BO}$	at $V_{BO}$	$T_j = 25^\circ C$		0.5		mA
$V_T$	$I_T = 2A$ $t_p \leq 500\mu s$	$T_j = 25^\circ C$		1.7		V
$\alpha T$			0.27			$V/^\circ C$

**Fig. 1:** Relative variation of breakover current versus junction temperature.

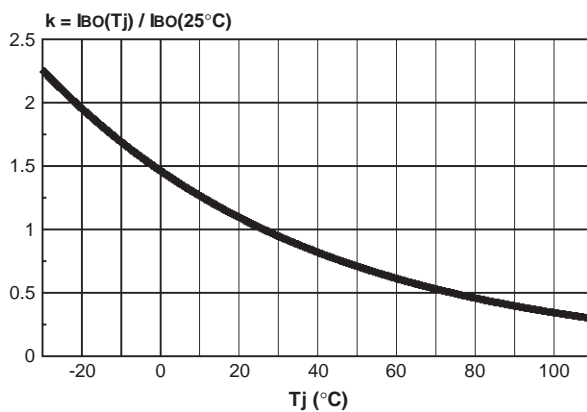
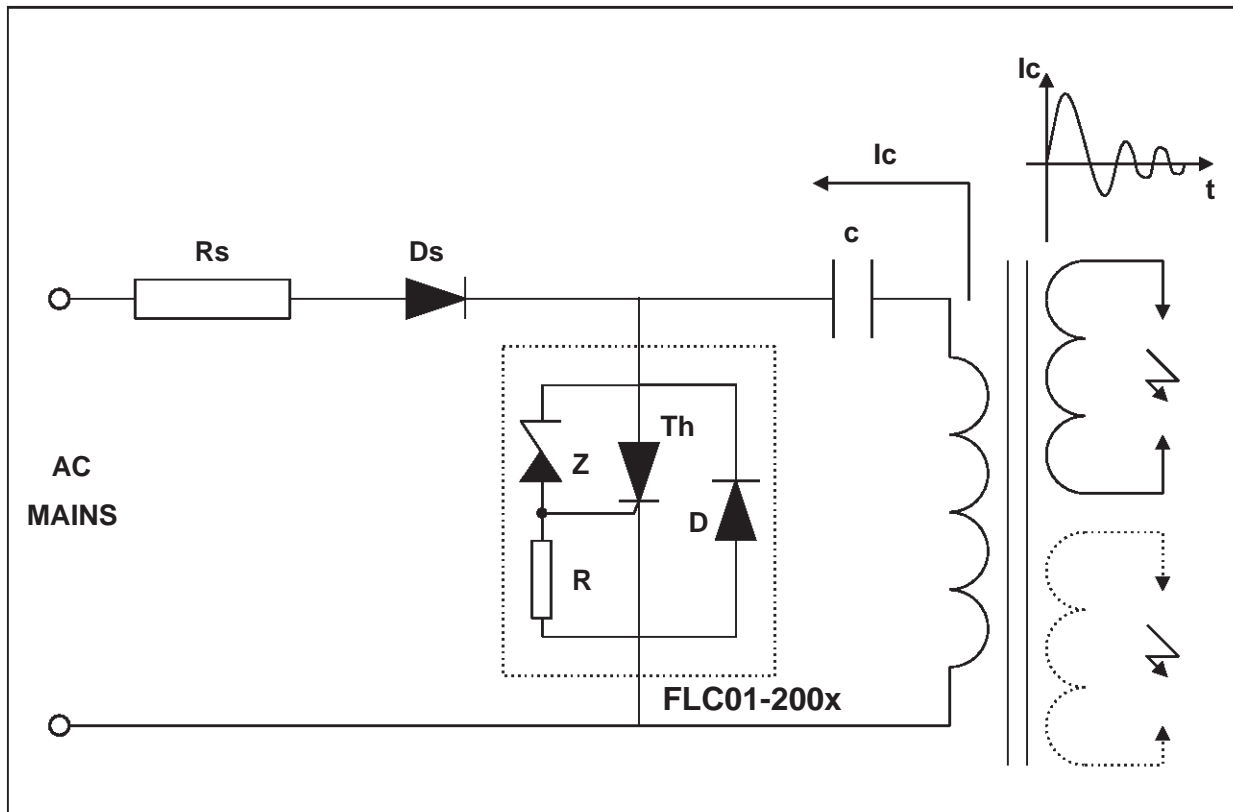

Fig. 2: BASIC APPLICATION



The applications of the lighter using the capacitance discharge topology operate in 2 phases :

**PHASE 1**

The energy coming from the mains is stored into the capacitor C. For that, the AC voltage is rectified by the diode Ds.

**PHASE 2**

At the end of the phase 1, the voltage across the capacitor C reaches the avalanche threshold of the zener. Then a current flows through the gate of the thyristor Th which fires. The firing of the thyristor causes an alternating current to flow through the capacitor C. The positive parts of this current flow through C, Th and the primary of the HV transformer. The negative parts of the current flow through C, D and the primary of the HV transformer.

**RS RESISTOR CALCULATION**

The Rs resistor allows, in addition with the capacitor C, the spark frequency to be adjusted and the current from the mains to be limited. Its value shall allow the thyristor Th to fire even in the worst case. In this case the system must fire with the lower RMS mains voltage value while the breakdown voltage and current of the FLC are at the maximum.

The maximum Rs value is equal to :

$$Rs_{max} = \frac{(V_{AC} \min. \cdot \sqrt{2}) - [V_{BO} \max. \cdot (1 + \alpha T. (T_{amb} - 25))]}{k \cdot I_{BO}^*}$$

\* : see fig 1

Fig. 3: Spark frequency versus  $R_s$  and  $C$

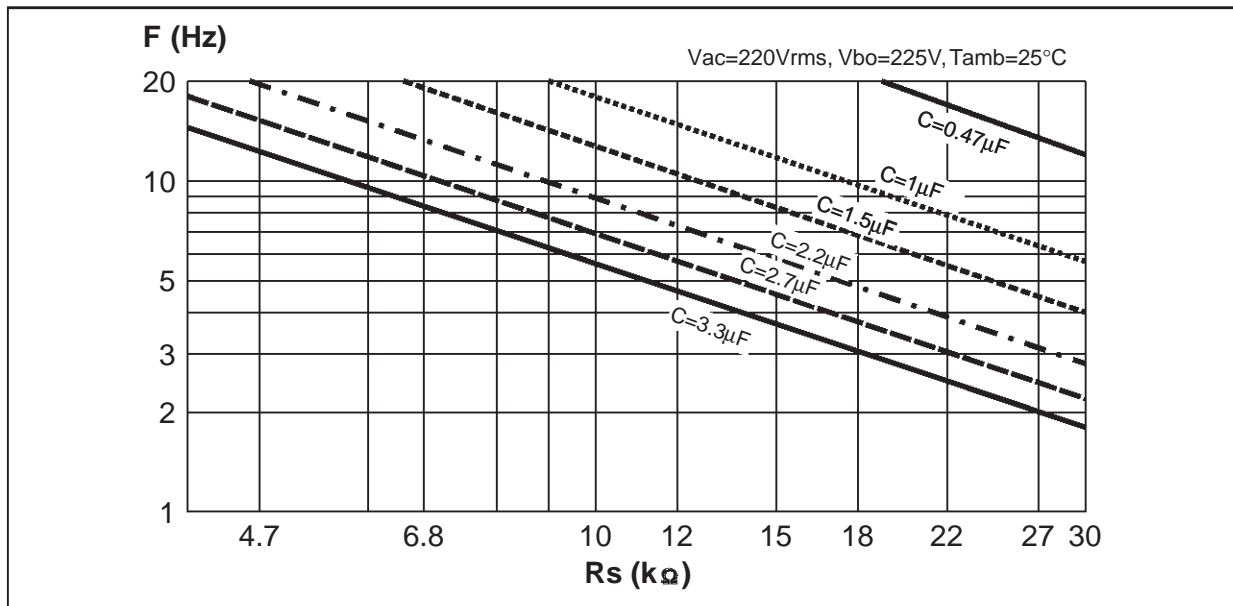

The couple  $R_s/C$  can be chosen with the previous curve. Keep in mind the  $R_s$  maximum limit for which the system would not work when the AC

mains is minimum. The next curve shows the behavior with  $R_s=15k\Omega$  and  $C=1\mu F$ .

Fig. 4: Voltage across the capacitance with  $R_s = 15k\Omega$ ,  $C = 1\mu F$  and  $V_{BO} = 225V$ .

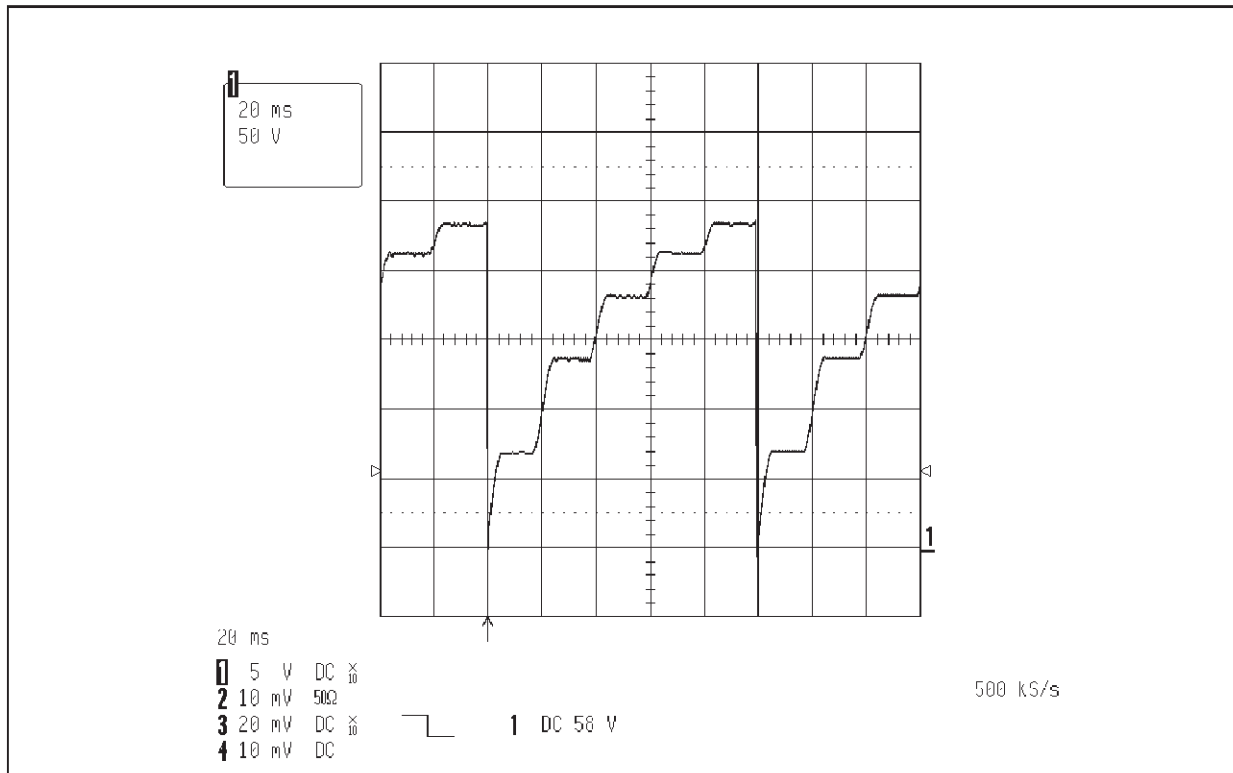

**PEAK CURRENT LIMIT**

This component is designed to withstand  $I_{TRM} = 190A$  for a pulse duration of  $10\mu s$  for an

ambient temperature of  $120^{\circ}C$  in repetitive surge. The curve of peak current versus the pulse duration allows us to verify if the application is within the FLC operating limit.

**Fig. 5:** Peak current limit

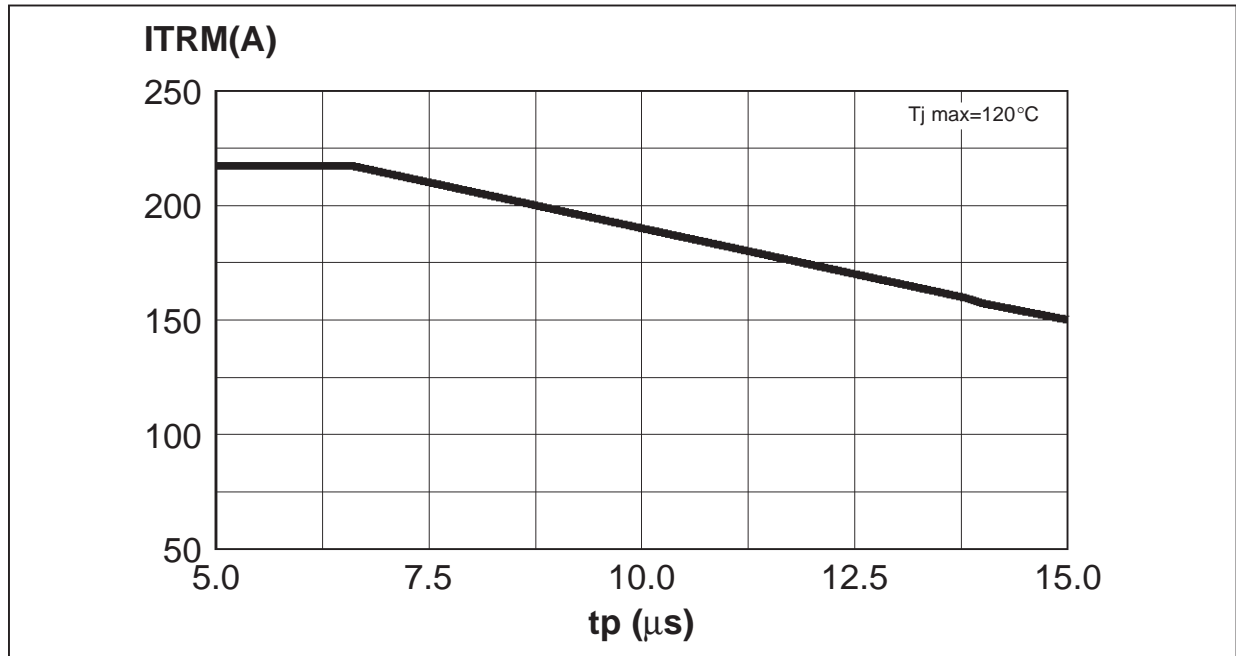

**POWER LOSSES** (For  $10\mu s$ , see note 1)

To evaluate the power losses, please use the following equations :

For the thyristor :  $P = 1.18 \times I_{T(AV)} + 0.035 I_{T(RMS)}^2$

For the diode :  $P = 0.67 \times I_{F(AV)} + 0.106 I_{F(RMS)}^2$

**PACKAGE MECHANICAL DATA**  
DPAK

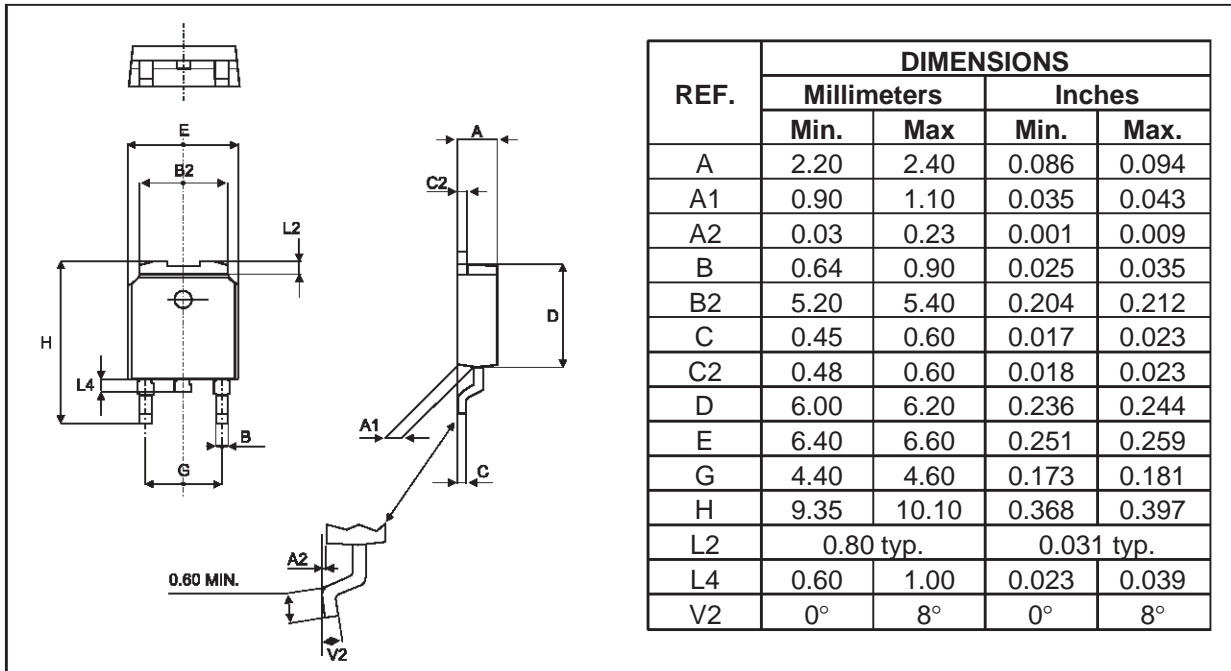

**FOOTPRINT (in millimeters)**

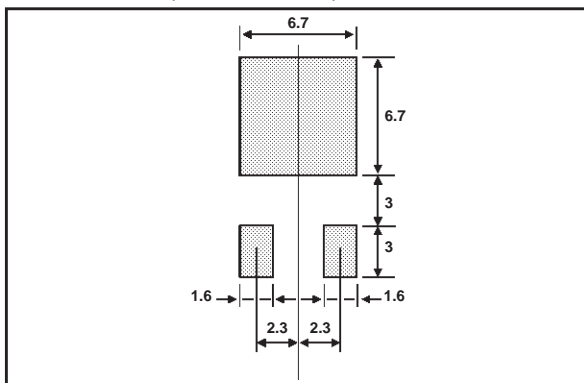

**FLC01-200x**

**PACKAGE MECHANICAL DATA**  
IPAK

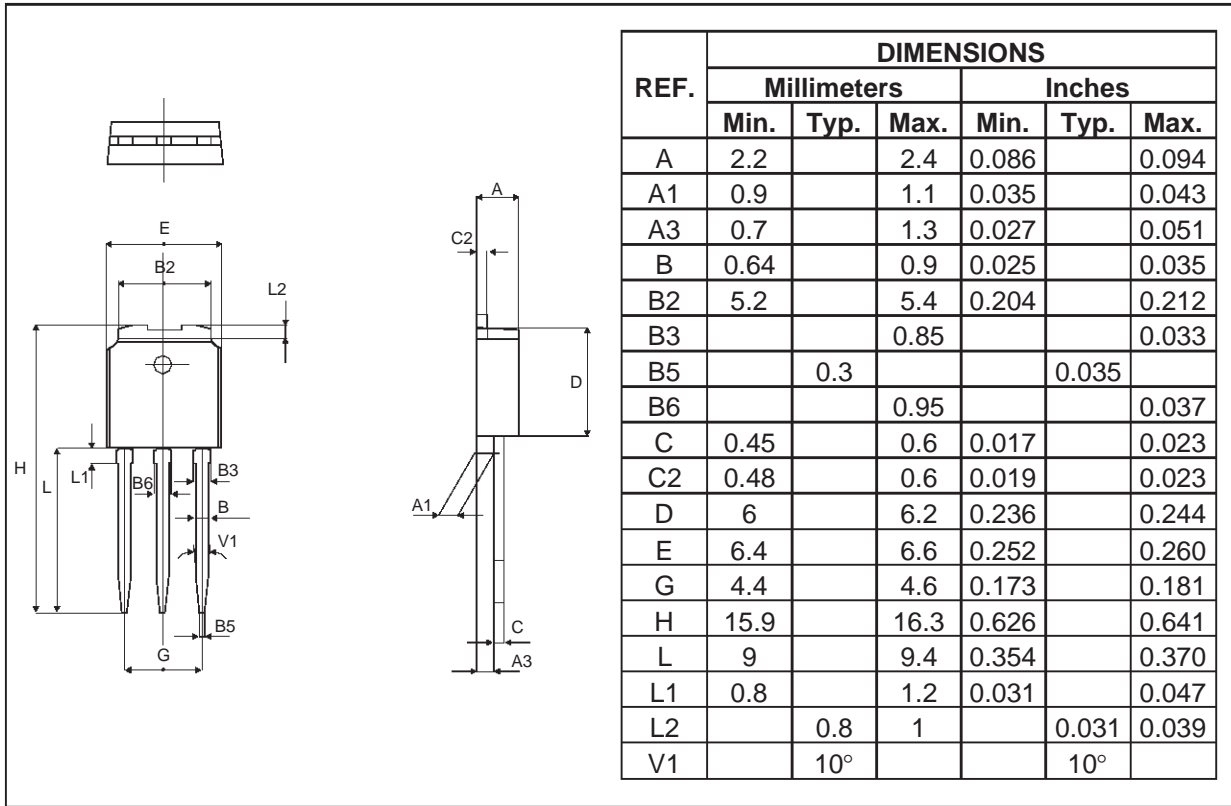

**OTHER INFORMATION**

Type	Marking	Package	Weight	Base qty	Delivery mode
FLC01-200H	FLC01-200H	IPAK	0.40 g	75	Tube
FLC01-200B	FLC01-200B	DPAK	0.40 g	75	Tube
FLC01-200B-TR	FLC01-200B	DPAK	0.40 g	2500	Tape & reel

Information furnished is believed to be accurate and reliable. However, STMicroelectronics assumes no responsibility for the consequences of use of such information nor for any infringement of patents or other rights of third parties which may result from its use. No license is granted by implication or otherwise under any patent or patent rights of STMicroelectronics. Specifications mentioned in this publication are subject to change without notice. This publication supersedes and replaces all information previously supplied. STMicroelectronics products are not authorized for use as critical components in life support devices or systems without express written approval of STMicroelectronics.

The ST logo is a registered trademark of STMicroelectronics  
 © 2002 STMicroelectronics - Printed in Italy - All rights reserved.  
 STMicroelectronics GROUP OF COMPANIES  
 Australia - Brazil - Canada - China - Finland - France - Germany  
 Hong Kong - India - Israel - Italy - Japan - Malaysia - Malta - Morocco - Singapore  
 Spain - Sweden - Switzerland - United Kingdom - United States.

<http://www.st.com>

