

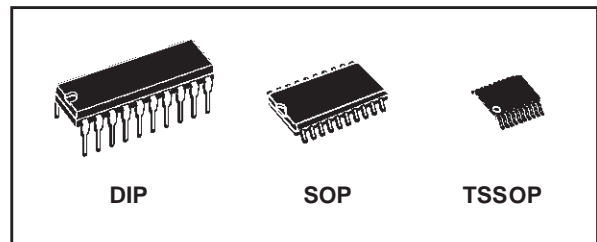

# M74HCT373

## OCTAL D-TYPE LATCH WITH 3 STATE OUTPUT NON INVERTING

- HIGH SPEED:  
 $t_{PD} = 19\text{ns}$  (TYP.) at  $V_{CC} = 4.5\text{V}$
- LOW POWER DISSIPATION:  
 $I_{CC} = 4\mu\text{A}$ (MAX.) at  $T_A = 25^\circ\text{C}$
- COMPATIBLE WITH TTL OUTPUTS :  
 $V_{IH} = 2\text{V}$  (MIN.)  $V_{IL} = 0.8\text{V}$  (MAX)
- SYMMETRICAL OUTPUT IMPEDANCE:  
 $|I_{OH}| = I_{OL} = 6\text{mA}$  (MIN)
- BALANCED PROPAGATION DELAYS:  
 $t_{PLH} \approx t_{PHL}$
- PIN AND FUNCTION COMPATIBLE WITH 74 SERIES 373



### ORDER CODES

PACKAGE	TUBE	T & R
DIP	M74HCT373B1R	
SOP	M74HCT373M1R	M74HCT373RM13TR
TSSOP		M74HCT373TTR

### DESCRIPTION

The M74HCT373 is an high speed CMOS OCTAL LATCH WITH 3-STATE OUTPUTS fabricated with sub-micron silicon gate C<sup>2</sup>MOS technology. This 8-BIT D-Type latches is controlled by a latch enable input (LE) and output enable input ( $\overline{OE}$ ). While the LE input is held at a high level, the Q outputs will follow the data input. When the LE is taken low, the Q outputs will be latched at the logic level of D input data. While the  $\overline{OE}$  input is at low level, the eight outputs will be in a normal logic state (high or low logic

level) and when  $\overline{OE}$  is in high level the outputs will be in a high impedance state. The 3-State output configuration and the wide choice of outline make bus organized system simple. All inputs are equipped with protection circuits against static discharge and transient excess voltage.

### PIN CONNECTION AND IEC LOGIC SYMBOLS

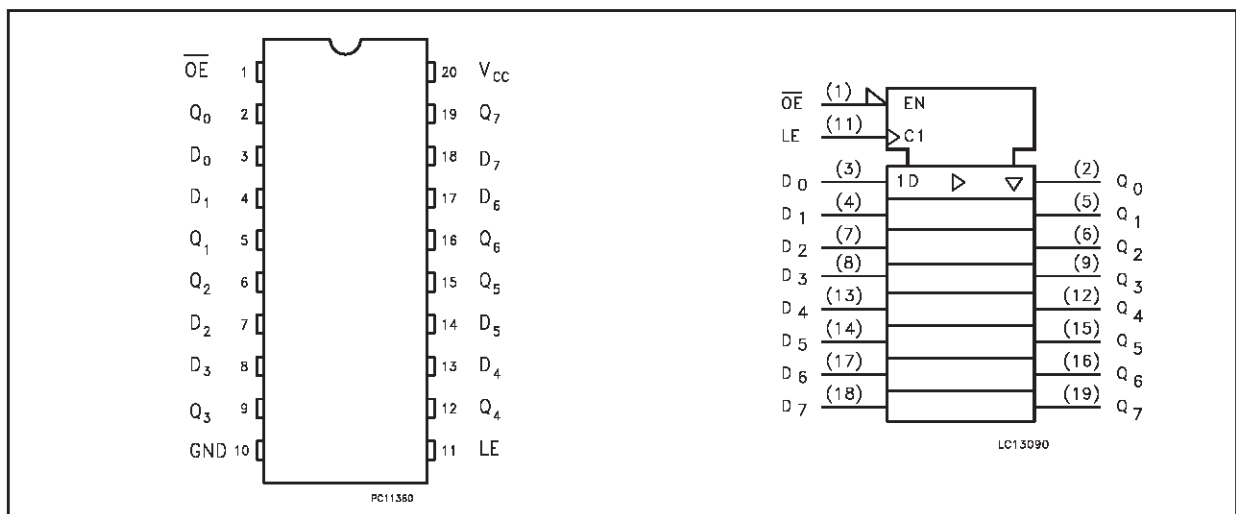

# M74HCT373

## INPUT AND OUTPUT EQUIVALENT CIRCUIT

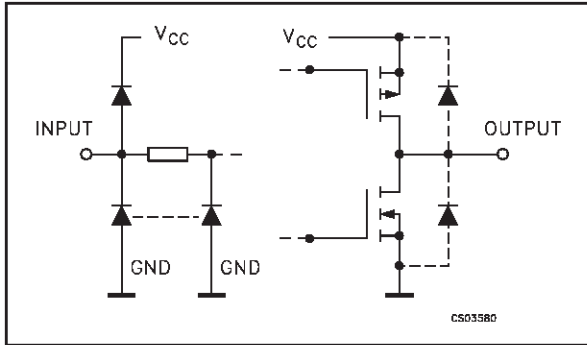

## PIN DESCRIPTION

PIN No	SYMBOL	NAME AND FUNCTION
1	$\overline{OE}$	3 State Output Enable Input (Active LOW)
2, 5, 6, 9, 12, 15, 16, 19	Q0 to Q7	3 State Outputs
3, 4, 7, 8, 13, 14, 17, 18	D0 to D7	Data Inputs
11	LE	Latch Enable Input
10	GND	Ground (0V)
20	V <sub>CC</sub>	Positive Supply Voltage

## TRUTH TABLE

INPUTS			OUTPUTS
$\overline{OE}$	LE	D	Q
H	X	X	Z
L	L	X	NO CHANGE (*)
L	H	L	L
L	H	H	H

X: Don't Care  
 Z: High Impedance  
 (\*): Q Outputs are latched at the time when the LE input is taken low logic level.

## LOGIC DIAGRAM

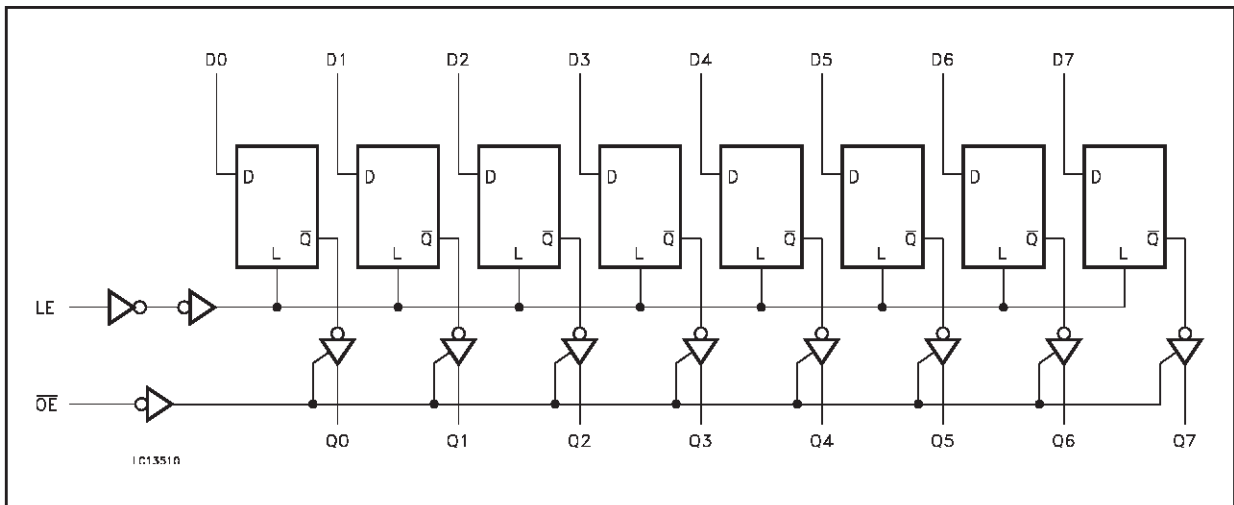

**ABSOLUTE MAXIMUM RATINGS**

Symbol	Parameter	Value	Unit
$V_{CC}$	Supply Voltage	-0.5 to +7	V
$V_I$	DC Input Voltage	-0.5 to $V_{CC} + 0.5$	V
$V_O$	DC Output Voltage	-0.5 to $V_{CC} + 0.5$	V
$I_{IK}$	DC Input Diode Current	$\pm 20$	mA
$I_{OK}$	DC Output Diode Current	$\pm 20$	mA
$I_O$	DC Output Current	$\pm 35$	mA
$I_{CC}$ or $I_{GND}$	DC $V_{CC}$ or Ground Current	$\pm 70$	mA
$P_D$	Power Dissipation	500(*)	mW
$T_{stg}$	Storage Temperature	-65 to +150	°C
$T_L$	Lead Temperature (10 sec)	300	°C

Absolute Maximum Ratings are those values beyond which damage to the device may occur. Functional operation under these conditions is not implied

(\*) 500mW at 65 °C; derate to 300mW by 10mW/°C from 65°C to 85°C

**RECOMMENDED OPERATING CONDITIONS**

Symbol	Parameter	Value	Unit
$V_{CC}$	Supply Voltage	4.5 to 5.5	V
$V_I$	Input Voltage	0 to $V_{CC}$	V
$V_O$	Output Voltage	0 to $V_{CC}$	V
$T_{op}$	Operating Temperature	-55 to 125	°C
$t_r, t_f$	Input Rise and Fall Time ( $V_{CC} = 4.5$ to $5.5V$ )	0 to 500	ns

## DC SPECIFICATIONS

Symbol	Parameter	Test Condition		Value						Unit	
		V <sub>CC</sub> (V)		T <sub>A</sub> = 25°C			-40 to 85°C		-55 to 125°C		
				Min.	Typ.	Max.	Min.	Max.	Min.		Max.
V <sub>IH</sub>	High Level Input Voltage	4.5 to 5.5		2.0			2.0		2.0		V
V <sub>IL</sub>	Low Level Input Voltage	4.5 to 5.5				0.8		0.8		0.8	V
V <sub>OH</sub>	High Level Output Voltage	4.5	I <sub>O</sub> = -20 μA	4.4	4.5		4.4		4.4		V
			I <sub>O</sub> = -6.0 mA	4.18	4.31		4.13		4.10		
V <sub>OL</sub>	Low Level Output Voltage	4.5	I <sub>O</sub> = 20 μA		0.0	0.1		0.1		0.1	V
			I <sub>O</sub> = 6.0 mA		0.17	0.26		0.33		0.40	
I <sub>I</sub>	Input Leakage Current	5.5	V <sub>I</sub> = V <sub>CC</sub> or GND			± 0.1		± 1		± 1	μA
I <sub>OZ</sub>	High Impedance Output Leakage Current	5.5	V <sub>I</sub> = V <sub>IH</sub> or V <sub>IL</sub> V <sub>O</sub> = V <sub>CC</sub> or GND			± 0.5		± 5		± 10	μA
I <sub>CC</sub>	Quiescent Supply Current	5.5	V <sub>I</sub> = V <sub>CC</sub> or GND			4		40		80	μA
Δ I <sub>CC</sub>	Additional Worst Case Supply Current	5.5	Per Input pin V <sub>I</sub> = 0.5V or V <sub>I</sub> = 2.4V Other Inputs at V <sub>CC</sub> or GND I <sub>O</sub> = 0			2.0		2.9		3.0	mA

AC ELECTRICAL CHARACTERISTICS ( $C_L = 50$  pF, Input  $t_r = t_f = 6$  ns)

Symbol	Parameter	Test Condition			Value						Unit	
		$V_{CC}$ (V)	$C_L$ (pF)		$T_A = 25^\circ\text{C}$			$-40$ to $85^\circ\text{C}$		$-55$ to $125^\circ\text{C}$		
					Min.	Typ.	Max.	Min.	Max.	Min.		Max.
$t_{TLH}$ $t_{THL}$	Output Transition Time	4.5	50			7	12		15		18	ns
$t_{PLH}$ $t_{PHL}$	Propagation Delay Time (LE - Q)	4.5	50			20	30		38		45	ns
			150			24	37		46		56	
$t_{PLH}$ $t_{PHL}$	Propagation Delay Time (D - Q)	4.5	50			19	30		38		45	ns
			150			23	36		45		54	
$t_{PZL}$ $t_{PZH}$	High Impedance Output Enable Time	4.5	50	$R_L = 1\text{ K}\Omega$		20	30		38		45	ns
			150			24	37		46		56	
$t_{PLZ}$ $t_{PHZ}$	High Impedance Output Disable Time	4.5	50	$R_L = 1\text{ K}\Omega$		20	30		38		45	ns
$t_{W(H)}$	Minimum Pulse Width (LE)	4.5	50			8	15		19		22	ns
$t_s$	Minimum Set-up Time	4.5	50			4	10		13		15	ns
$t_h$	Minimum Hold Time	4.5	50				5		5		8	ns

## CAPACITIVE CHARACTERISTICS

Symbol	Parameter	Test Condition		Value						Unit	
		$V_{CC}$ (V)		$T_A = 25^\circ\text{C}$			$-40$ to $85^\circ\text{C}$		$-55$ to $125^\circ\text{C}$		
				Min.	Typ.	Max.	Min.	Max.	Min.		Max.
$C_{IN}$	Input Capacitance				5	10		10		10	pF
$C_{PD}$	Power Dissipation Capacitance (note 1)				66						pF

1)  $C_{PD}$  is defined as the value of the IC's internal equivalent capacitance which is calculated from the operating current consumption without load. (Refer to Test Circuit). Average operating current can be obtained by the following equation:  $I_{CC(opr)} = C_{PD} \times V_{CC} \times f_{IN} + I_{CC}/8$  (per Flip Flop) and the  $C_{PD}$  when  $n$  pcs of Flip Flop operate, can be gained by the following equation:  $C_{PD(TOTAL)} = 32 + 34 \times n$  (pF)

TEST CIRCUIT

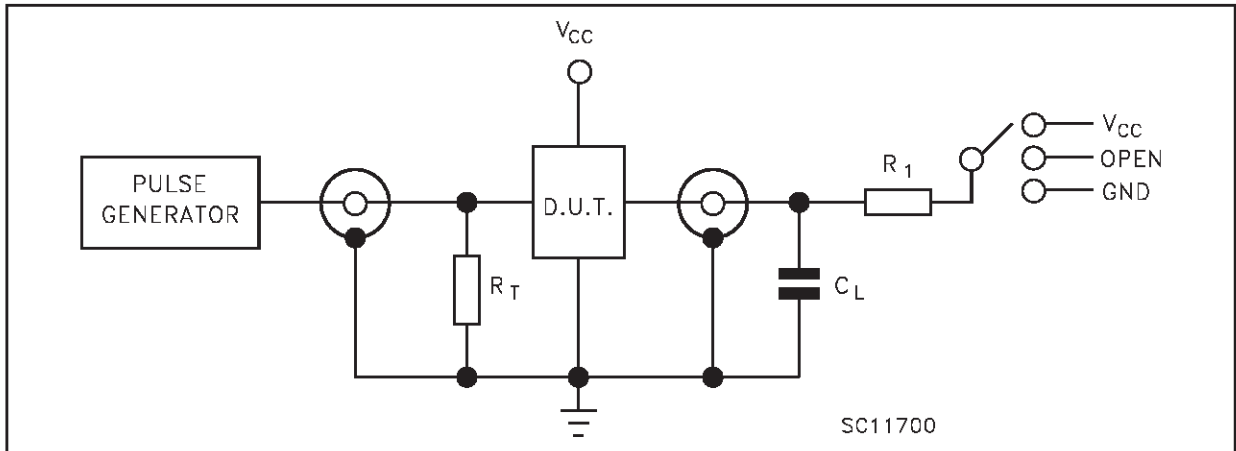

TEST	SWITCH
$t_{PLH}$ , $t_{PHL}$	Open
$t_{PZL}$ , $t_{PLZ}$	$V_{CC}$
$t_{PZH}$ , $t_{PHZ}$	GND

$C_L$  = 50pF/150pF or equivalent (includes jig and probe capacitance)  
 $R_1$  = 1K $\Omega$  or equivalent  
 $R_T$  =  $Z_{OUT}$  of pulse generator (typically 50 $\Omega$ )

**WAVEFORM 1: LE TO Qn PROPAGATION DELAYS, LE MINIMUM PULSE WIDTH, Dn TO LE SETUP AND HOLD TIMES (f=1MHz; 50% duty cycle)**

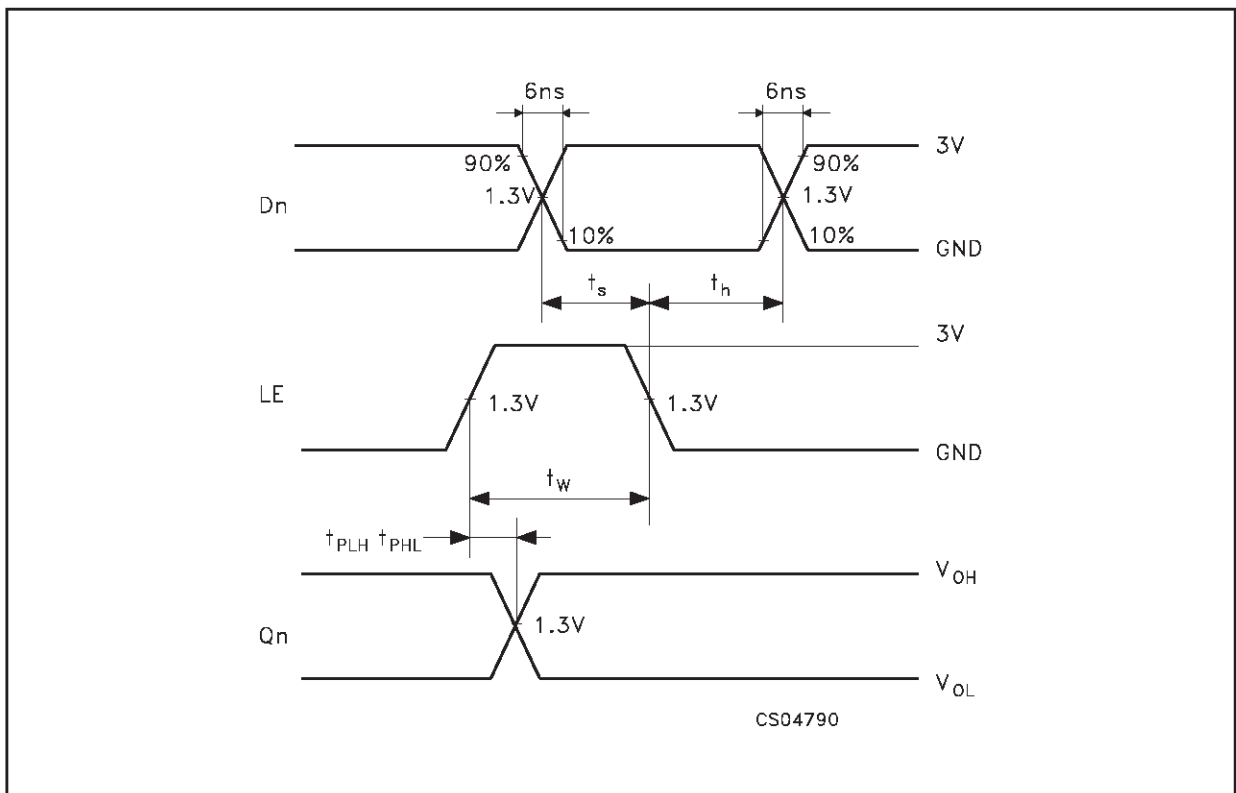

WAVEFORM 2: OUTPUT ENABLE AND DISABLE TIMES (f=1MHz; 50% duty cycle)

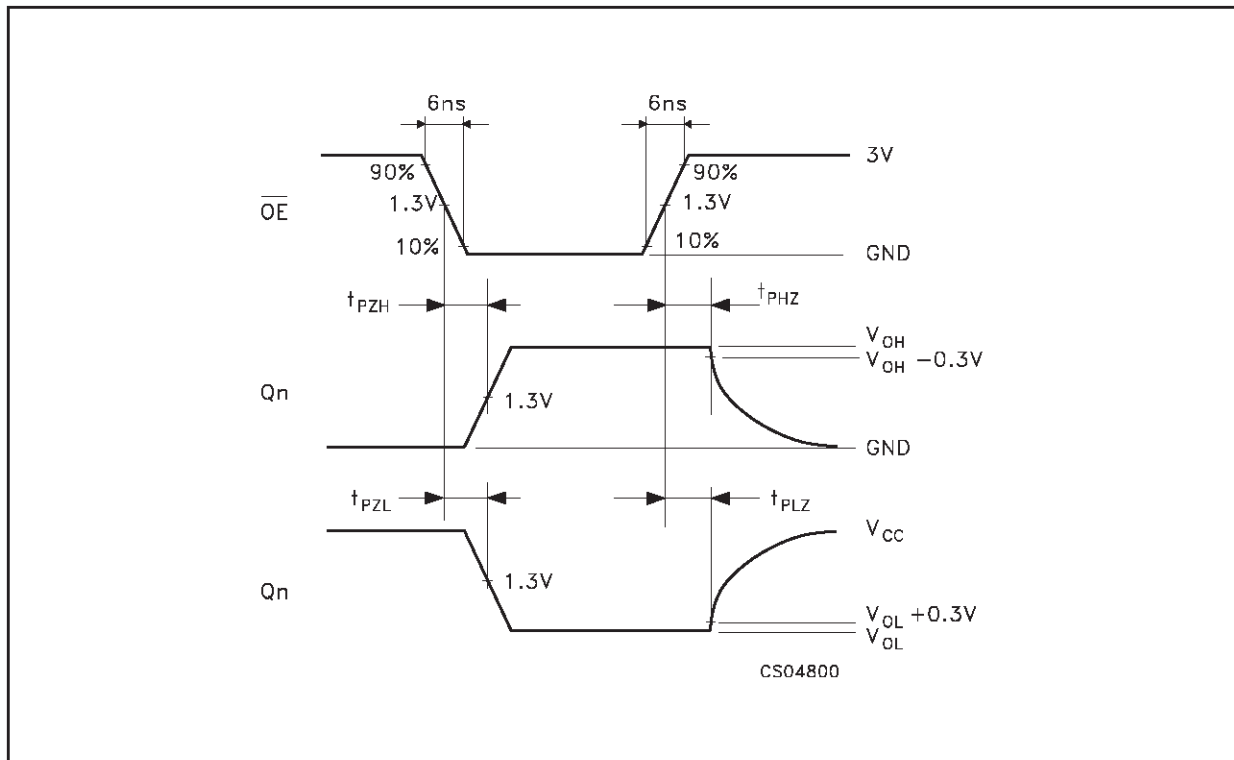

WAVEFORM 3: PROPAGATION DELAY TIMES (f=1MHz; 50% duty cycle)

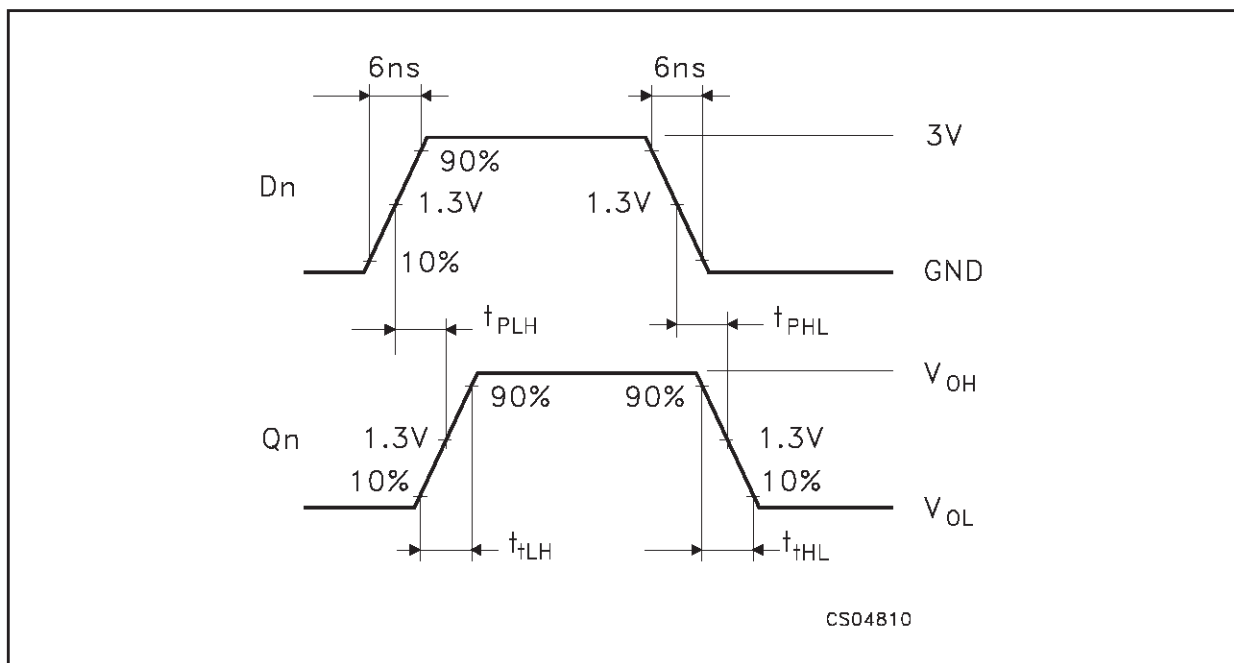

<b>Plastic DIP-20 (0.25) MECHANICAL DATA</b>						
--	--	--	--	--	--	--

DIM.	mm.			inch		
	MIN.	TYP.	MAX.	MIN.	TYP.	MAX.
a1	0.254			0.010		
B	1.39		1.65	0.055		0.065
b		0.45			0.018	
b1		0.25			0.010	
D			25.4			1.000
E		8.5			0.335	
e		2.54			0.100	
e3		22.86			0.900	
F			7.1			0.280
I			3.93			0.155
L		3.3			0.130	
Z			1.34			0.053

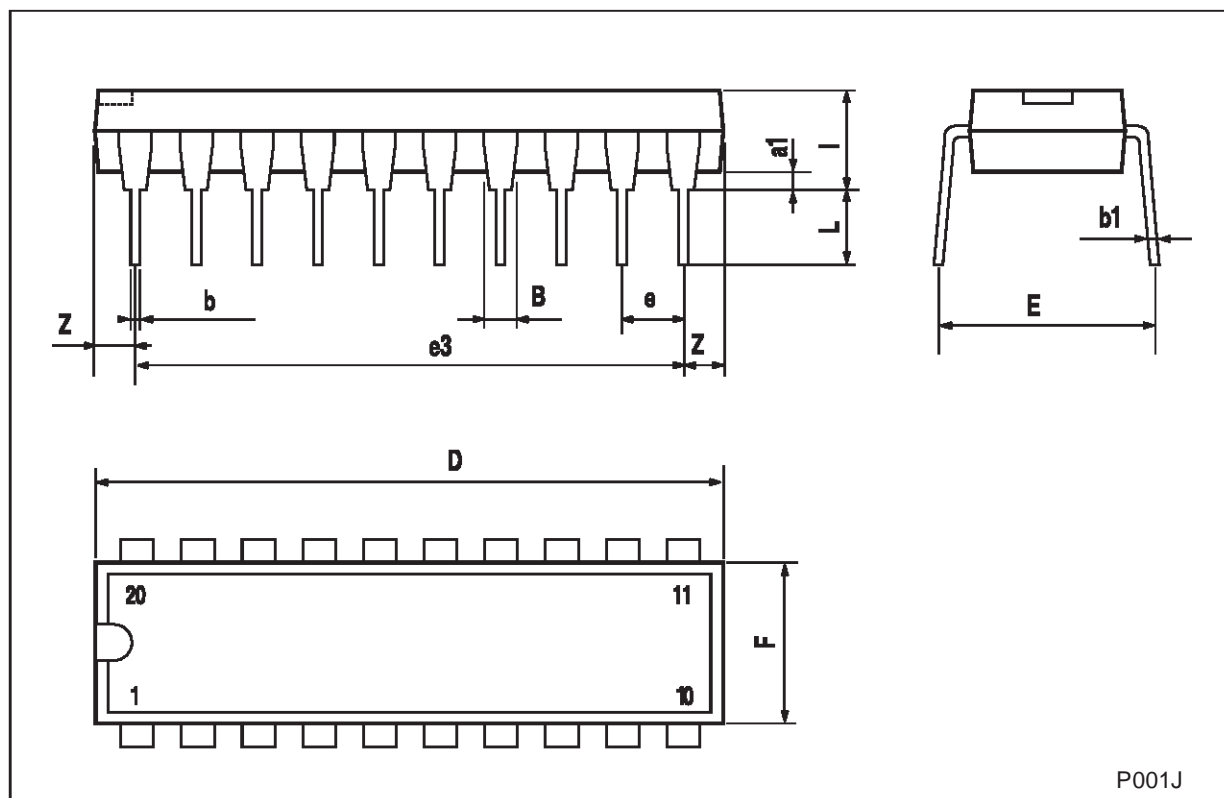

## SO-20 MECHANICAL DATA

DIM.	mm.			inch		
	MIN.	TYP.	MAX.	MIN.	TYP.	MAX.
A			2.65			0.104
a1	0.1		0.2	0.004		0.008
a2			2.45			0.096
b	0.35		0.49	0.014		0.019
b1	0.23		0.32	0.009		0.012
C		0.5			0.020	
c1	45° (typ.)					
D	12.60		13.00	0.496		0.512
E	10.00		10.65	0.393		0.419
e		1.27			0.050	
e3		11.43			0.450	
F	7.40		7.60	0.291		0.300
L	0.50		1.27	0.020		0.050
M			0.75			0.029
S	8° (max.)					

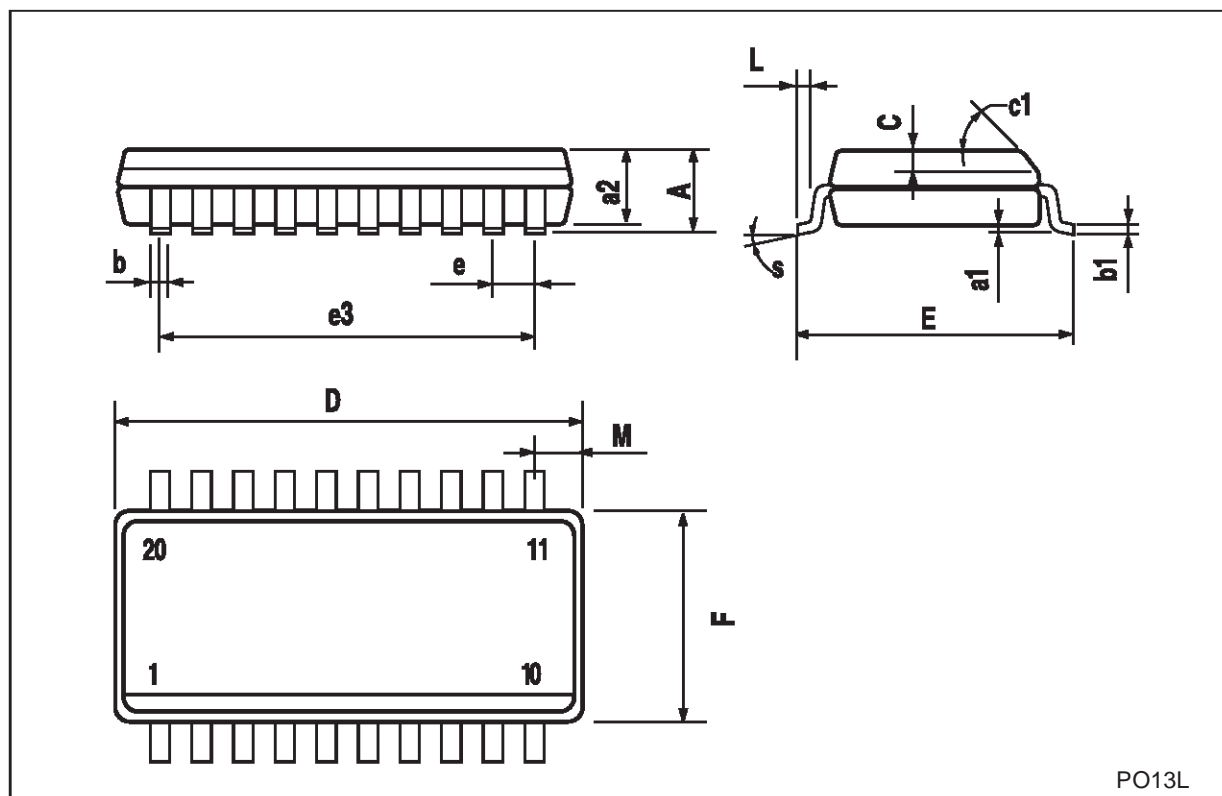

PO13L



Information furnished is believed to be accurate and reliable. However, STMicroelectronics assumes no responsibility for the consequences of use of such information nor for any infringement of patents or other rights of third parties which may result from its use. No license is granted by implication or otherwise under any patent or patent rights of STMicroelectronics. Specifications mentioned in this publication are subject to change without notice. This publication supersedes and replaces all information previously supplied. STMicroelectronics products are not authorized for use as critical components in life support devices or systems without express written approval of STMicroelectronics.

© The ST logo is a registered trademark of STMicroelectronics

© 2000 STMicroelectronics - Printed in Italy - All Rights Reserved  
STMicroelectronics GROUP OF COMPANIES

Australia - Brazil - China - Finland - France - Germany - Hong Kong - India - Italy - Japan - Malaysia - Malta - Morocco  
Singapore - Spain - Sweden - Switzerland - United Kingdom

© <http://www.st.com>

