



# TS861

## SINGLE BiCMOS RAIL TO RAIL 3V $\mu$ POWER COMPARATOR

- RAIL TO RAIL INPUTS
- PUSH PULL OUTPUT
- VERY LOW FALL & RISE TIME : 20ns
- VERY LOW PROPAGATION DELAY : 500ns
- SUPPLY OPERATION FROM 2.7V TO 10V
- ULTRA LOW CURRENT CONSUMPTION :  
6 $\mu$ A @  $V_{CC} = 3V$
- ESD PROTECTION : 2KV (HBM) 200V (MM)
- AVAILABLE IN TINY SOT23-5 PACKAGE

### DESCRIPTION

The TS861 is a RAIL TO RAIL single BiCMOS comparator optimized and fully specified for 2.7V, 5V and 10V operations.

The TS861 exhibits an excellent speed to power consumption ratio, making this device an excellent choice for battery operated systems.

The TS861 has a push-pull output allowing direct connection to microcontroller without pull-up resistors.

### APPLICATIONS

- Cordless telephones and portable communication equipments
- Metering systems
- Portable computers
- Battery powered alarms

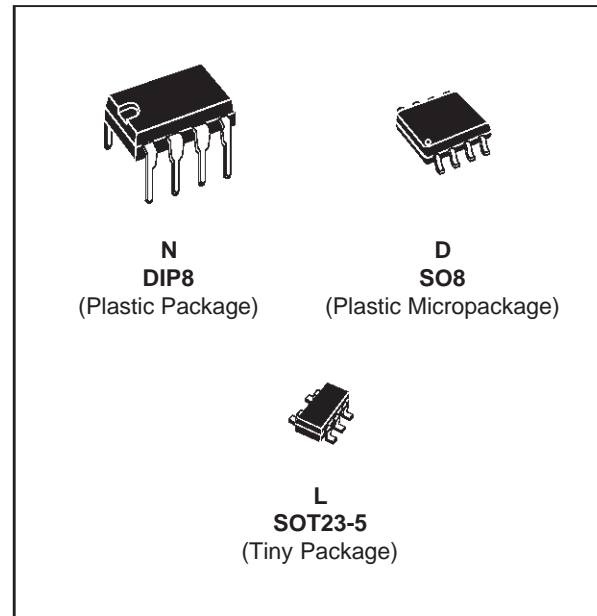

### ORDER CODES

Part Number	Temperature Range	Package			SOT23-5 Marking
		N	D	L	
TS861I	-40°C, +85°C	•	•	•	K501
TS861AI		•	•	•	K502

Example : TS861IN

### PIN CONNECTIONS (top view)

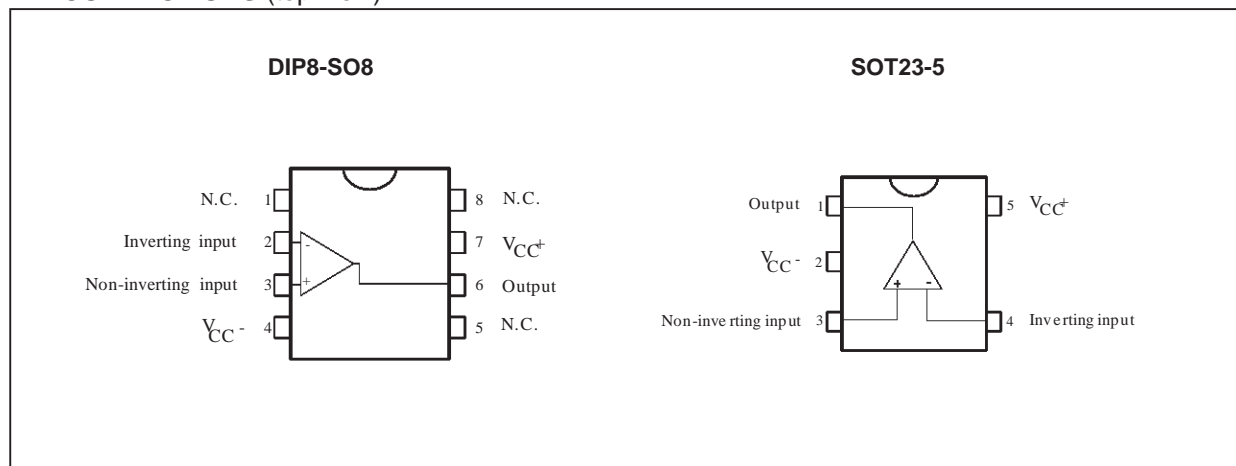

**ABSOLUTE MAXIMUM RATINGS**

Symbol	Parameter	Value	Unit
$V_{CC}$	Supply Voltage - (note 1)	12	V
$V_{id}$	Differential Input Voltage - (note 2)	$\pm 12$	V
$V_i$	Input Voltage - (note 3)	-0.3 to +12	V
$T_{oper}$	Operating Free Air Temperature Range	-40 to +85	$^{\circ}\text{C}$
$T_{stg}$	Storage Temperature	-65 to +150	$^{\circ}\text{C}$
$T_j$	Maximum Junction Temperature	150	$^{\circ}\text{C}$
$P_d$	Maximum power dissipation - (note 4)	SOT23-5 SO8 DIP8	500 715 1200 mW

- Notes :**
1. All voltages values, except differential voltage, are with respect to network ground terminal.
  2. Differential voltages are non-inverting input terminal with respect to the inverting input terminal.
  3. The magnitude of input and output voltages must never exceed  $V_{CC} + 0.3\text{V}$ .
  4.  $T_j = 150^{\circ}\text{C}$ ,  $T_{amb} = 25^{\circ}\text{C}$  with
    - $R_{thja} = 250^{\circ}\text{C}/\text{W}$  for SOT23-5 package
    - $R_{thja} = 175^{\circ}\text{C}/\text{W}$  for SO8 package
    - $R_{thja} = 100^{\circ}\text{C}/\text{W}$  for DIP8 package

**OPERATING CONDITIONS**

Symbol	Parameter	Value	Unit
$V_{CC}$	Supply Voltage	2.7 to 10	V
$V_{icm}$	Common Mode Input Voltage Range	$(V_{CC}^-) - 0.3$ to $(V_{CC}^+) + 0.3$	V

**ELECTRICAL CHARACTERISTICS** $V_{CC}^+ = 2.7V$ ,  $T_{amb} = 25^{\circ}C$  (unless otherwise specified)

Symbol	Parameter	Min.	Typ.	Max.	Unit
$V_{io}$	Input Offset Voltage (Full common mode range) TS861A $T_{amb} = +25^{\circ}C$ $T_{min.} \leq T_{amb} \leq T_{max.}$ TS861 $T_{amb} = +25^{\circ}C$ $T_{min.} \leq T_{amb} \leq T_{max.}$			7 10 15 18	mV
$DV_{io}$	Input Offset Voltage Drift		6		$\mu V/^{\circ}C$
$I_{io}$	Input Offset Current $T_{amb} = +25^{\circ}C$ $T_{min.} \leq T_{amb} \leq T_{max.}$		1	300	pA
$I_{ib}$	Input Bias Current $T_{amb} = +25^{\circ}C$ $T_{min.} \leq T_{amb} \leq T_{max.}$		1	600	pA
$V_{oh}$	High Level Output Voltage - $I_{source} = 2.5mA$ $T_{min.} \leq T_{amb} \leq T_{max.}$	2.35 2.15	2.45		V
$V_{ol}$	Low Level Output Voltage - $I_{sink} = 2.5mA$ $T_{min.} \leq T_{amb} \leq T_{max.}$		0.2	0.35 0.45	V
$A_{vd}$	Large Signal Voltage Gain (design evaluation)		240		dB
CMR	Common-mode Rejection Ratio $0 < V_{icm} < 2.7V$		65		dB
SVR	Supply Voltage Rejection Ratio $2.7 < V_{CC} < 10V$		80		dB
$I_{cc}$	Supply Current No load, output low No load, output high		6 8	12 14	$\mu A$
$t_{plh}$	Response Time Low to High $V_{ic} = 1.35V$ , $f = 10kHz$ , $C_L = 50pF$ Overdrive = 10mV Overdrive = 100mV		1.5 0.6		$\mu s$
$t_{phl}$	Response Time High to Low $V_{ic} = 1.35V$ , $f = 10kHz$ , $C_L = 50pF$ Overdrive = 10mV Overdrive = 100mV		1.5 0.5		$\mu s$
$t_f$	Fall Time $f = 10kHz$ , $C_L = 50pF$ Overdrive = 100mV		20		ns
$t_r$	Rise Time $f = 10kHz$ , $C_L = 50pF$ Overdrive = 100mV		20		ns

**ELECTRICAL CHARACTERISTICS**

$V_{CC}^+ = 5V$ ,  $T_{amb} = 25^{\circ}C$  (unless otherwise specified)

Symbol	Parameter	Min.	Typ.	Max.	Unit
$V_{io}$	Input Offset Voltage (Full common mode range) TS861A $T_{amb} = +25^{\circ}C$ $T_{min.} \leq T_{amb} \leq T_{max.}$ TS861 $T_{amb} = +25^{\circ}C$ $T_{min.} \leq T_{amb} \leq T_{max.}$			7 10 15 18	mV
$DV_{io}$	Input Offset Voltage Drift		6		$\mu V/^{\circ}C$
$I_{io}$	Input Offset Current $T_{amb} = +25^{\circ}C$ $T_{min.} \leq T_{amb} \leq T_{max.}$		1	300	pA
$I_{ib}$	Input Bias Current $T_{amb} = +25^{\circ}C$ $T_{min.} \leq T_{amb} \leq T_{max.}$		1	600	pA
$V_{oh}$	High Level Output Voltage - $I_{source} = 5mA$ $T_{min.} \leq T_{amb} \leq T_{max.}$	4.6 4.45	4.8		V
$V_{ol}$	Low Level Output Voltage - $I_{sink} = 5mA$ $T_{min.} \leq T_{amb} \leq T_{max.}$		0.2	0.4 0.55	V
$A_{vd}$	Large Signal Voltage Gain (design evaluation)		240		dB
CMR	Common-mode Rejection Ratio $0 < V_{icm} < 5V$		70		dB
SVR	Supply Voltage Rejection Ratio $2.7 < V_{CC} < 10V$		80		dB
$I_{cc}$	Supply Current No load, output low No load, output high		6 8	12 14	$\mu A$
$t_{plh}$	Response Time Low to High $V_{ic} = 2.5V$ , $f = 10kHz$ , $C_L = 50pF$ Overdrive = 10mV Overdrive = 100mV		2 0.5		$\mu s$
$t_{phl}$	Response Time High to Low $V_{ic} = 2.5V$ , $f = 10kHz$ , $C_L = 50pF$ Overdrive = 10mV Overdrive = 100mV		2 0.4		$\mu s$
$t_f$	Fall Time $f = 10kHz$ , $C_L = 50pF$ Overdrive = 100mV		20		ns
$t_r$	Rise Time $f = 10kHz$ , $C_L = 50pF$ Overdrive = 100mV		20		ns

**ELECTRICAL CHARACTERISTICS** $V_{CC}^+ = 10V$ ,  $T_{amb} = 25^{\circ}C$  (unless otherwise specified)

Symbol	Parameter	Min.	Typ.	Max.	Unit
$V_{io}$	Input Offset Voltage ( $V_{icm} = V_{CC}/2$ ) TS861 $T_{amb} = +25^{\circ}C$ $T_{min.} \leq T_{amb} \leq T_{max.}$			15 18	mV
$DV_{io}$	Input Offset Voltage Drift		6		$\mu V/^{\circ}C$
$I_{io}$	Input Offset Current $T_{amb} = +25^{\circ}C$ $T_{min.} \leq T_{amb} \leq T_{max.}$		1	300	pA
$I_{ib}$	Input Bias Current $T_{amb} = +25^{\circ}C$ $T_{min.} \leq T_{amb} \leq T_{max.}$		1	600	pA
$V_{oh}$	High Level Output Voltage - $I_{source} = 5mA$ $T_{min.} \leq T_{amb} \leq T_{max.}$	9.6 9.45	9.8		V
$V_{ol}$	Low Level Output Voltage - $I_{sink} = 5mA$ $T_{min.} \leq T_{amb} \leq T_{max.}$		0.2	0.4 0.55	V
$A_{vd}$	Large Signal Voltage Gain (design evaluation)		240		dB
CMR	Common-mode Rejection Ratio $0 < V_{icm} < 10V$		75		dB
SVR	Supply Voltage Rejection Ratio $2.7 < V_{CC} < 10V$		80		dB
$I_{CC}$	Supply Current No load, output low No load, output high		7 10	14 16	$\mu A$
$t_{plh}$	Response Time Low to High $V_{ic} = 5V$ , $f = 10kHz$ , $C_L = 50pF$ Overdrive = 10mV Overdrive = 100mV		3 0.5		$\mu s$
$t_{phl}$	Response Time High to Low $V_{ic} = 5V$ , $f = 10kHz$ , $C_L = 50pF$ Overdrive = 10mV Overdrive = 100mV		2.6 0.4		$\mu s$
$t_f$	Fall Time $f = 10kHz$ , $C_L = 50pF$ Overdrive = 100mV		20		ns
$t_r$	Rise Time $f = 10kHz$ , $C_L = 50pF$ Overdrive = 100mV		20		ns

**Input Offset Voltage ( $V_{io}$ ) vs Common Mode Voltage ( $V_{icm}$ )**

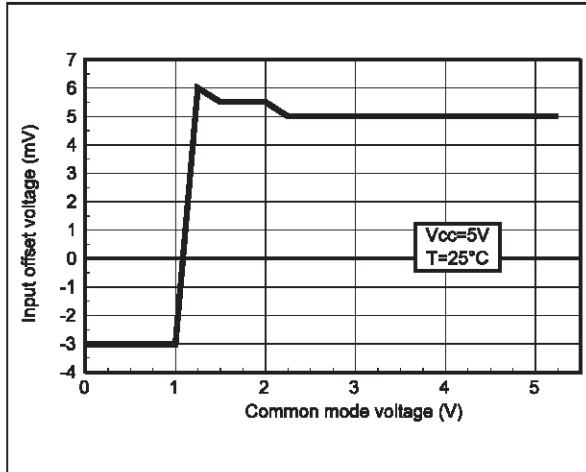

**Input Offset Voltage ( $V_{io}$ ) vs Supply Voltage ( $V_{CC}$ )**

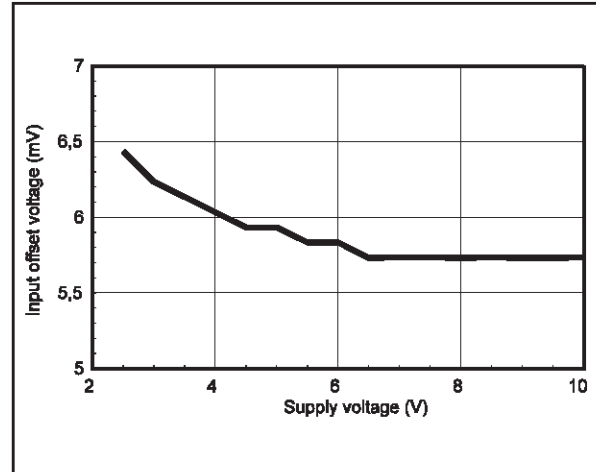

**Input Offset Voltage ( $V_{io}$ ) vs Temperature @  $V_{CC} = 5V$**

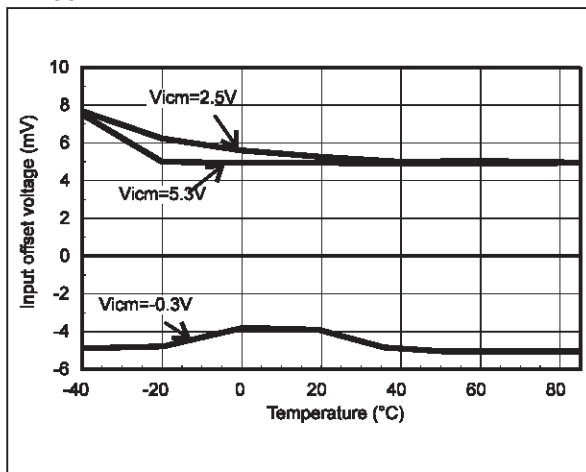

**Supply Current ( $I_{CC}$ ) vs Supply Voltage ( $V_{CC}$ )**

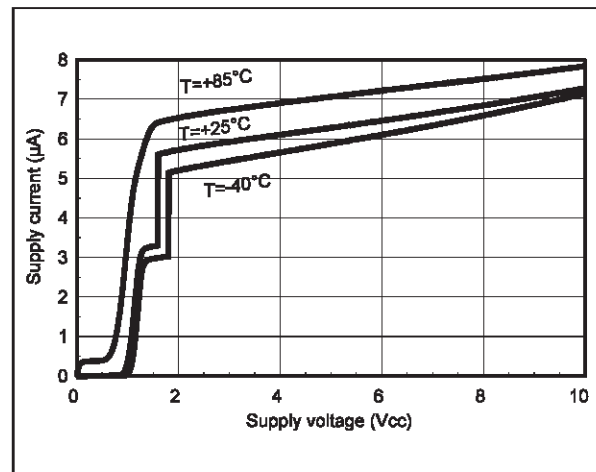

**Output Low Voltage ( $V_{ol}$ ) vs Sinking Current ( $I_{sink}$ ) @  $V_{CC} = 5V$**

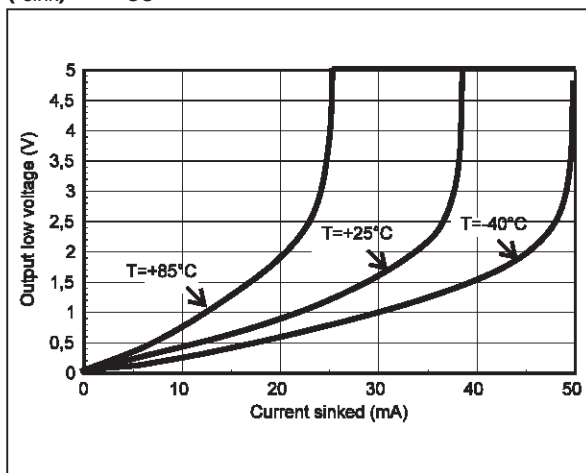

**Output High Voltage ( $V_{oh}$ ) vs Sourcing Current ( $I_{source}$ ) @  $V_{CC} = 5V$**

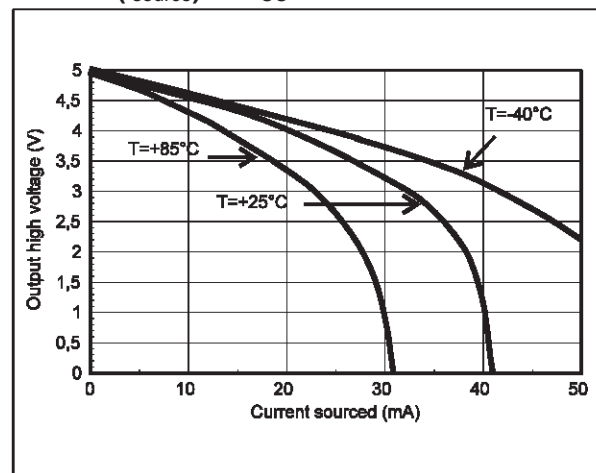

Supply Current ( $I_{CC}$ ) vs Temperature : Output Low

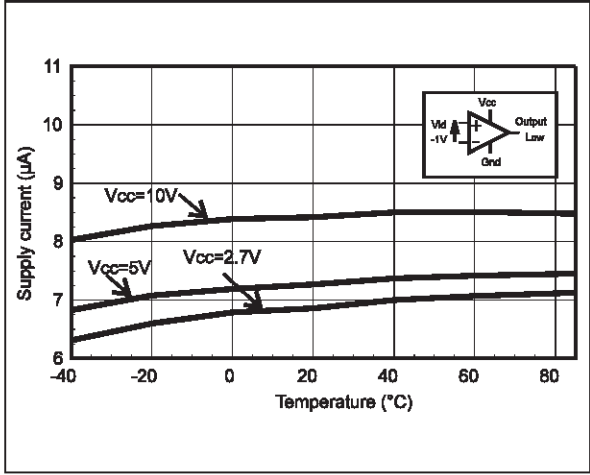

Supply Current ( $I_{CC}$ ) vs Temperature : Output High

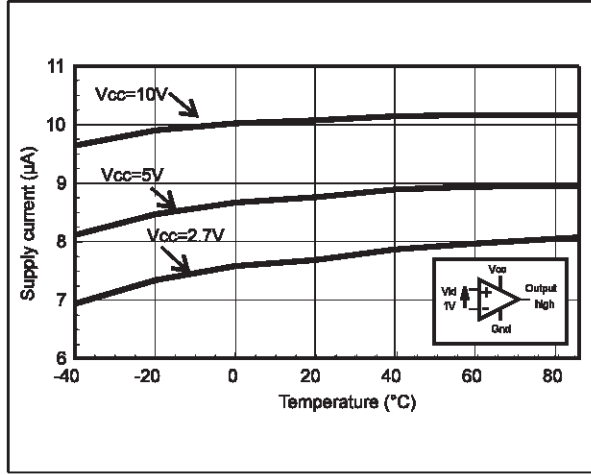

Response Time @ V<sub>CC</sub> = 5V

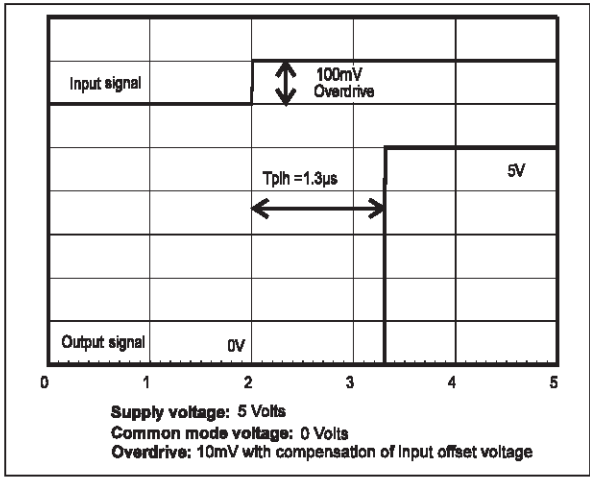

Response Time @ V<sub>CC</sub> = 5V

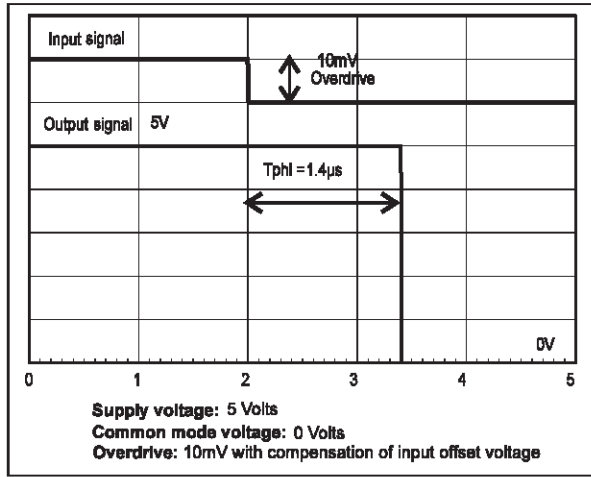

Response Time @ V<sub>CC</sub> = 5V

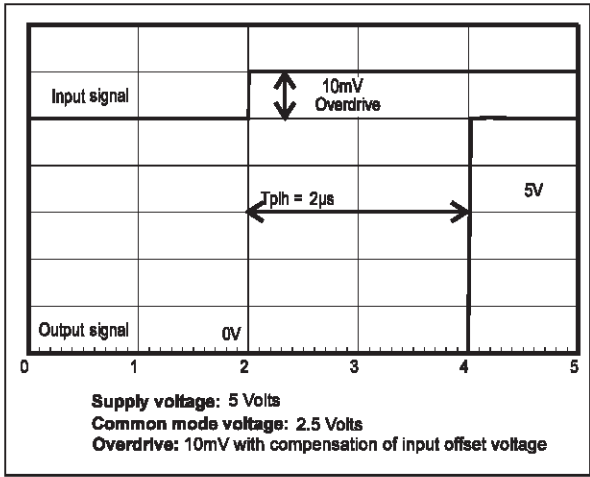

Response Time @ V<sub>CC</sub> = 5V

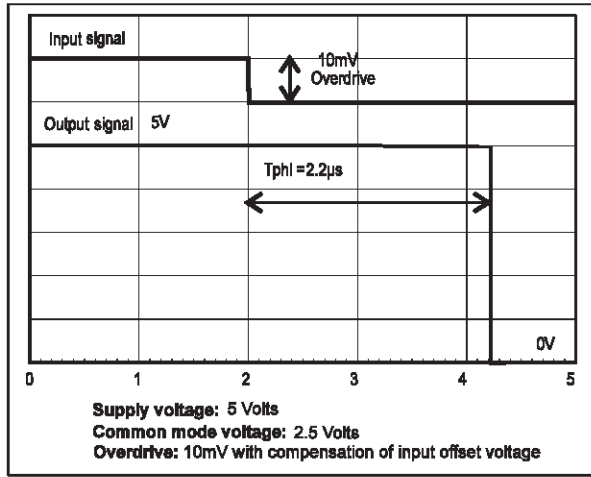

Response Time @  $V_{CC} = 5V$

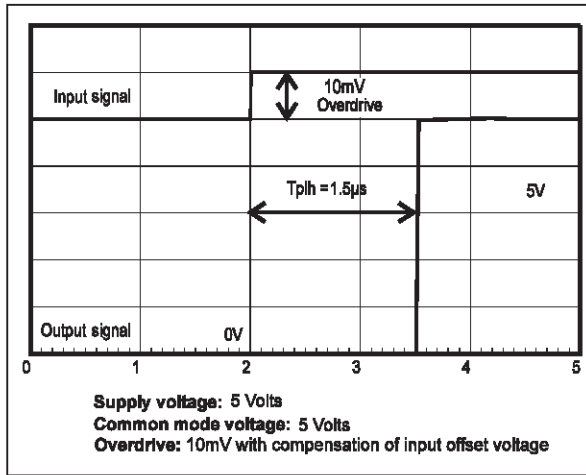

Response Time @  $V_{CC} = 5V$

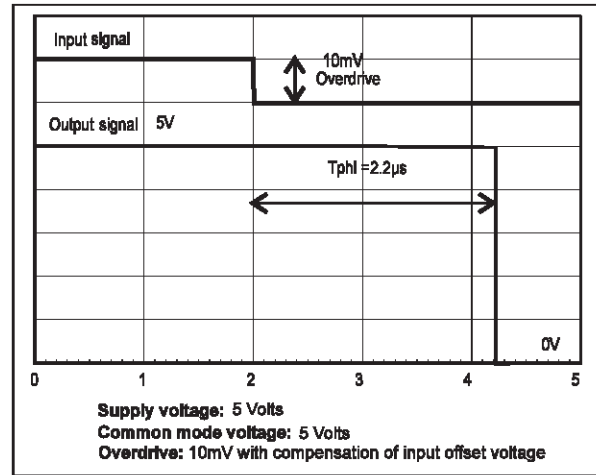

Response Time @  $V_{CC} = 5V$

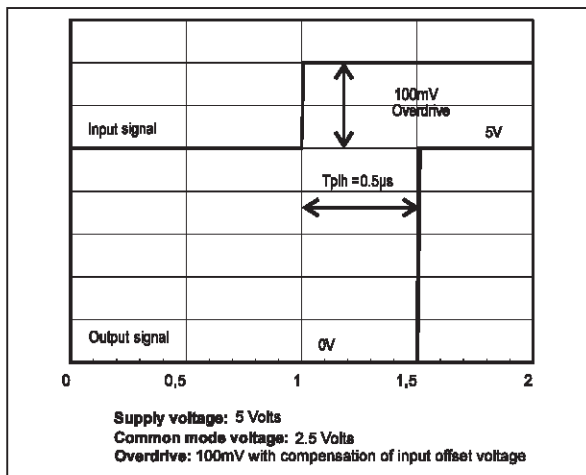

Response Time @  $V_{CC} = 5V$

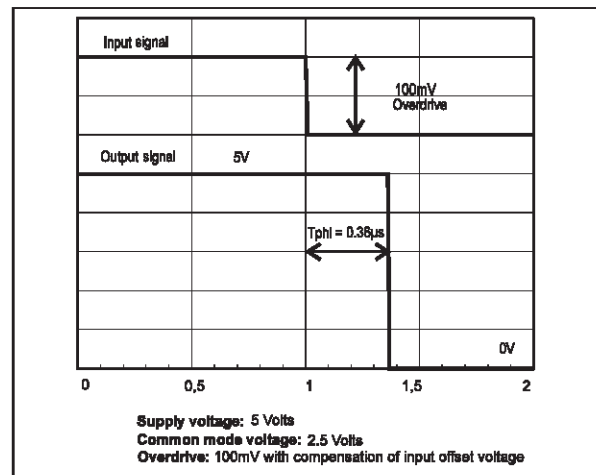

**PACKAGE MECHANICAL DATA**  
 8 PINS - PLASTIC PACKAGE

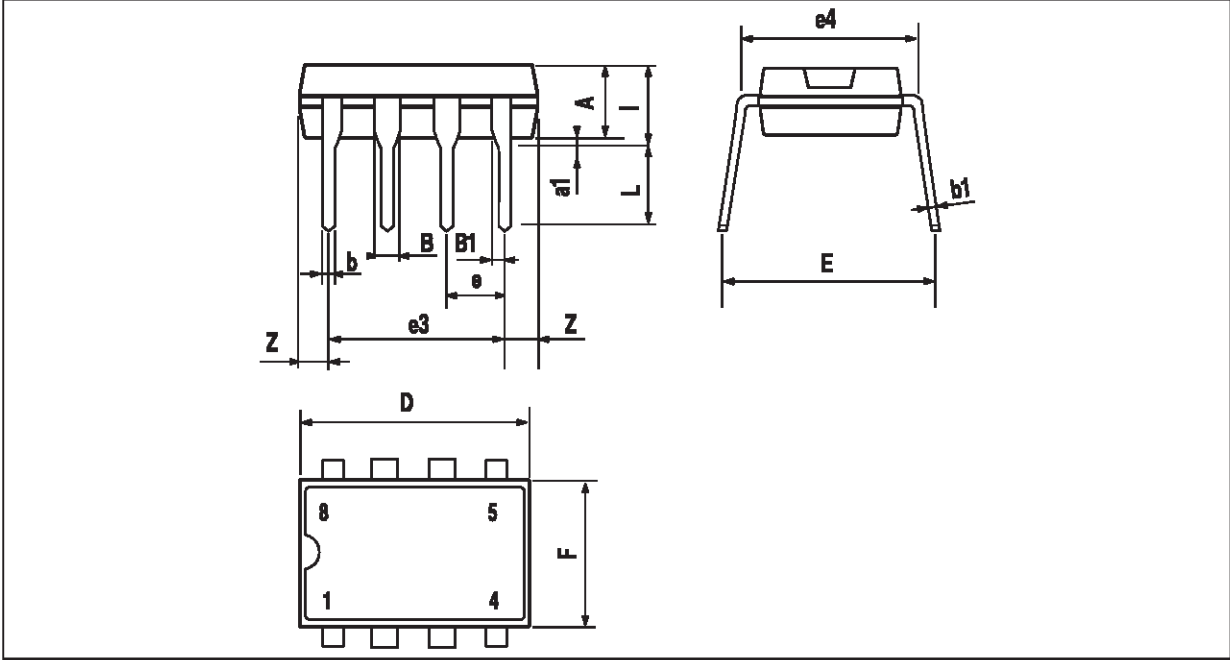

Dim.	Millimeters			Inches		
	Min.	Typ.	Max.	Min.	Typ.	Max.
A		3.32			0.131	
a1	0.51			0.020		
B	1.15		1.65	0.045		0.065
b	0.356		0.55	0.014		0.022
b1	0.204		0.304	0.008		0.012
D			10.92			0.430
E	7.95		9.75	0.313		0.384
e		2.54			0.100	
e3		7.62			0.300	
e4		7.62			0.300	
F			6.6			0.260
i			5.08			0.200
L	3.18		3.81	0.125		0.150
Z			1.52			0.060

**PACKAGE MECHANICAL DATA**  
 8 PINS - PLASTIC MICROPACKAGE (SO)

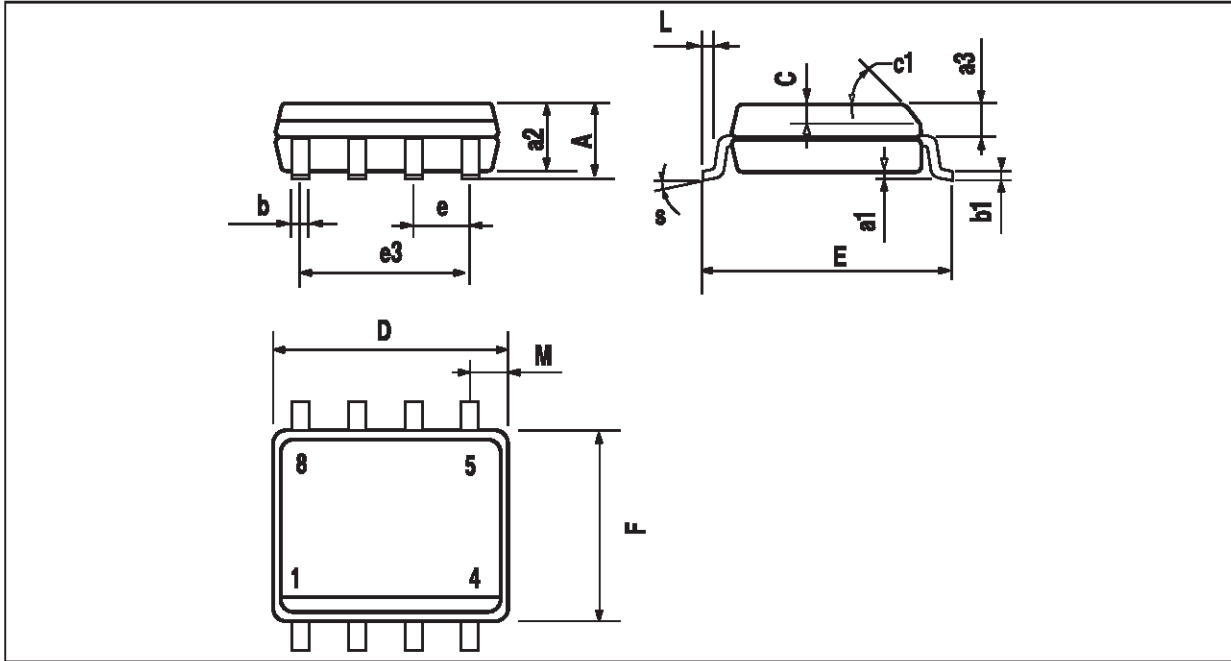

Dim.	Millimeters			Inches		
	Min.	Typ.	Max.	Min.	Typ.	Max.
A			1.75			0.069
a1	0.1		0.25	0.004		0.010
a2			1.65			0.065
a3	0.65		0.85	0.026		0.033
b	0.35		0.48	0.014		0.019
b1	0.19		0.25	0.007		0.010
C	0.25		0.5	0.010		0.020
c1	45° (typ.)					
D	4.8		5.0	0.189		0.197
E	5.8		6.2	0.228		0.244
e		1.27			0.050	
e3		3.81			0.150	
F	3.8		4.0	0.150		0.157
L	0.4		1.27	0.016		0.050
M			0.6			0.024
S	8° (max.)					

**PACKAGE MECHANICAL DATA**  
5 PINS - TINY PACKAGE (SOT23)

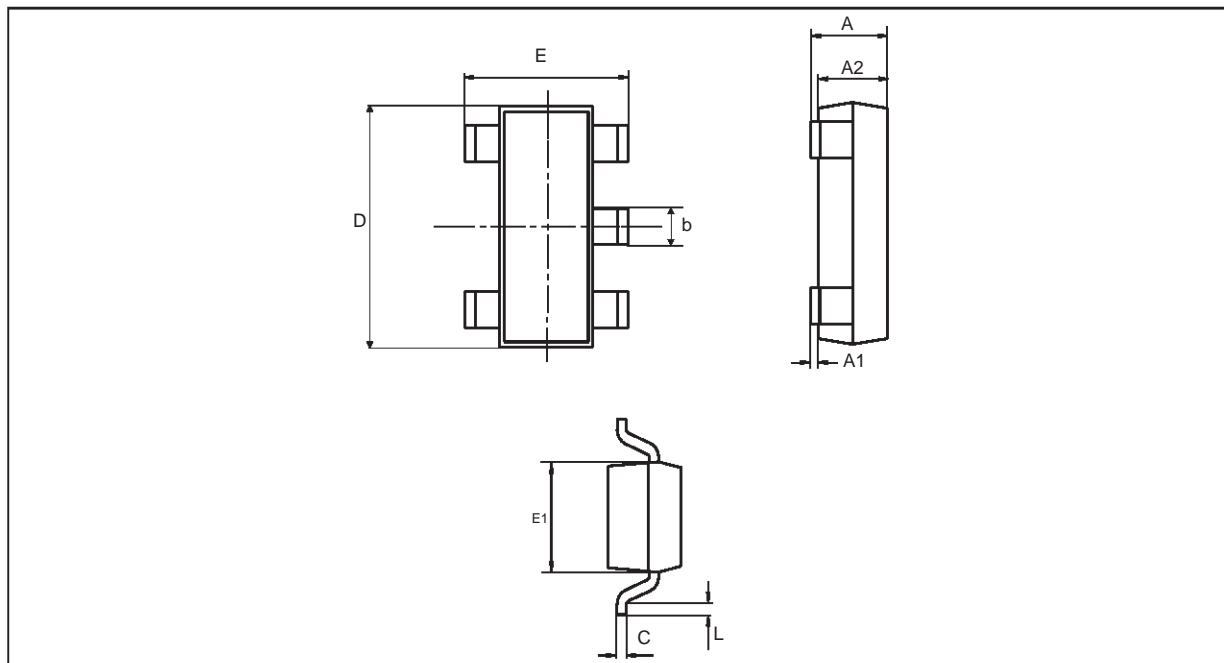

Dim.	Millimeters		Inches	
	Min.	Max.	Min.	Max.
A	0.90	1.45	0.034	0.057
A1	0	0.15		0.006
A2	0.90	1.30	0.034	0.051
b	0.35	0.50	0.013	0.020
C	0.09	0.20	0.003	0.008
D	2.80	3.00	0.110	0.118
E	2.60	3.00	0.102	0.118
E1	1.50	1.75	0.059	0.069
L	0.10	0.60	0.003	0.024

Information furnished is believed to be accurate and reliable. However, STMicroelectronics assumes no responsibility for the consequences of use of such information nor for any infringement of patents or other rights of third parties which may result from its use. No license is granted by implication or otherwise under any patent or patent rights of STMicroelectronics. Specifications mentioned in this publication are subject to change without notice. This publication supersedes and replaces all information previously supplied. STMicroelectronics products are not authorized for use as critical components in life support devices or systems without express written approval of STMicroelectronics.

© The ST logo is a trademark of STMicroelectronics

© 2000 STMicroelectronics – Printed in Italy – All Rights Reserved

STMicroelectronics GROUP OF COMPANIES

Australia - Brazil - China - Finland - France - Germany - Hong Kong - India - Italy - Japan - Malaysia - Malta - Morocco  
Singapore - Spain - Sweden - Switzerland - United Kingdom

© <http://www.st.com>