



VN800S VN800PT

HIGH SIDE DRIVER

PRELIMINARY DATA

TYPE	$R_{DS(on)}$	I_{OUT}	V_{CC}
VN800S	135 m Ω	0.7 A	36 V
VN800PT			

- CMOS COMPATIBLE INPUT
- THERMAL SHUTDOWN
- CURRENT LIMITATION
- SHORTED LOAD PROTECTION
- UNDERVOLTAGE AND OVERVOLTAGE SHUTDOWN
- PROTECTION AGAINST LOSS OF GROUND
- VERY LOW STAND-BY CURRENT
- REVERSE BATTERY PROTECTION (*)

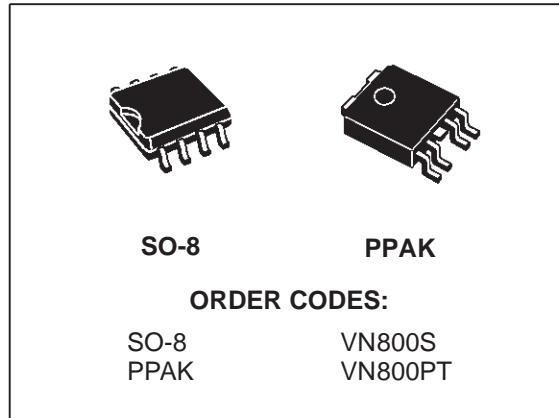

DESCRIPTION

The VN800S, VN800PT are monolithic devices made by using STMicroelectronics VIPower M0-3 Technology, intended for driving any kind of load with one side connected to ground. Active V_{CC} pin voltage clamp protects the device against low energy spikes (see ISO7637 transient compatibility table). Active current limitation

combined with thermal shutdown and automatic restart protect the device against overload. Device automatically turns off in case of ground pin disconnection. This device is especially suitable for industrial applications in norms conformity with IEC1131 (Programmable Controllers International Standard).

BLOCK DIAGRAM

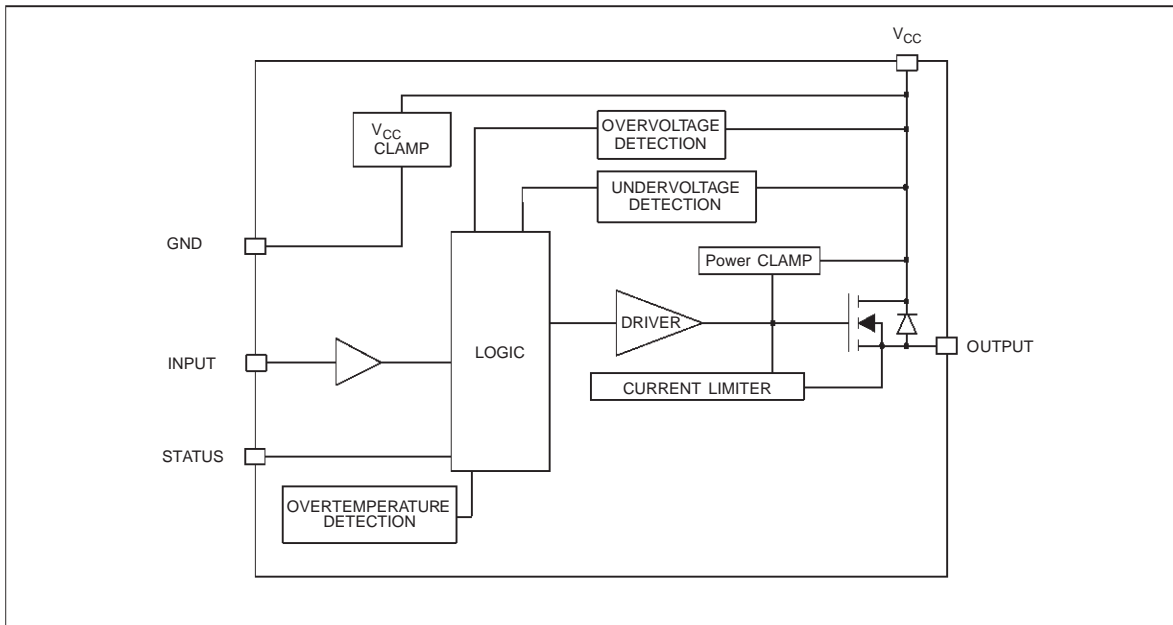

(*) See note at page 7

VN800S / VN800PT

ABSOLUTE MAXIMUM RATING

Symbol	Parameter	Value		Unit
		SO-8	PPAK	
V_{CC}	DC Supply Voltage	41		V
$-V_{CC}$	Reverse DC Supply Voltage	- 0.3		V
$-I_{GND}$	DC Reverse Ground Pin Current	- 200		mA
I_{OUT}	DC Output Current	Internally Limited		A
$-I_{OUT}$	Reverse DC Output Current	- 6		A
I_{IN}	DC Input Current	+/- 10		mA
V_{IN}	Input Voltage Range	-3/+ V_{CC}		V
V_{STAT}	DC Status Voltage	+ V_{CC}		V
V_{ESD}	Electrostatic Discharge (R=1.5 K Ω ; C=100 pF)	2000		V
P_{tot}	Power Dissipation $T_C=25^\circ\text{C}$	4.2	42	W
T_j	Junction Operating Temperature	Internally Limited		$^\circ\text{C}$
T_c	Case Operating Temperature	- 40 to 150		$^\circ\text{C}$
T_{stg}	Storage Temperature	- 55 to 150		$^\circ\text{C}$
L_{max}	Max Inductive Load ($V_{CC}=30\text{V}$; $R_{LOAD}=48\Omega$; $T_{amb}=100^\circ\text{C}$; $R_{th\text{case}>\text{ambient}}\leq 25^\circ\text{C/W}$)		2	H

CONNECTION DIAGRAM (TOP VIEW)

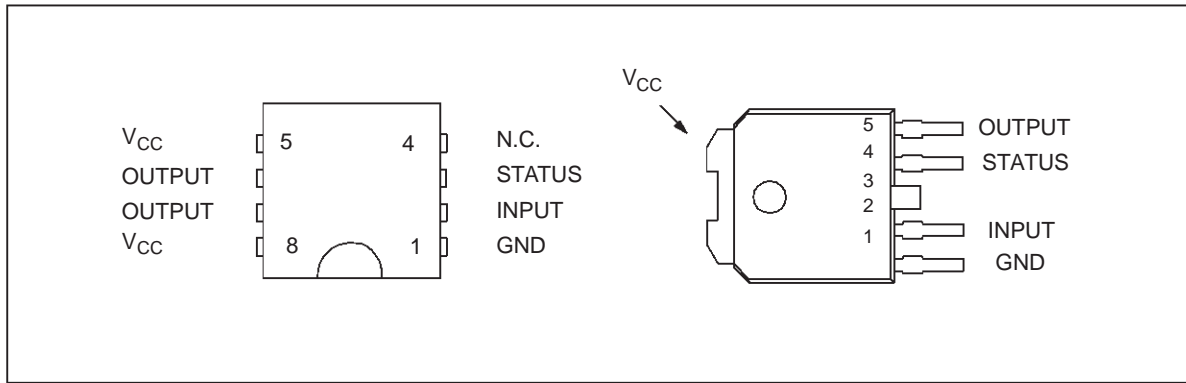

CURRENT AND VOLTAGE CONVENTIONS

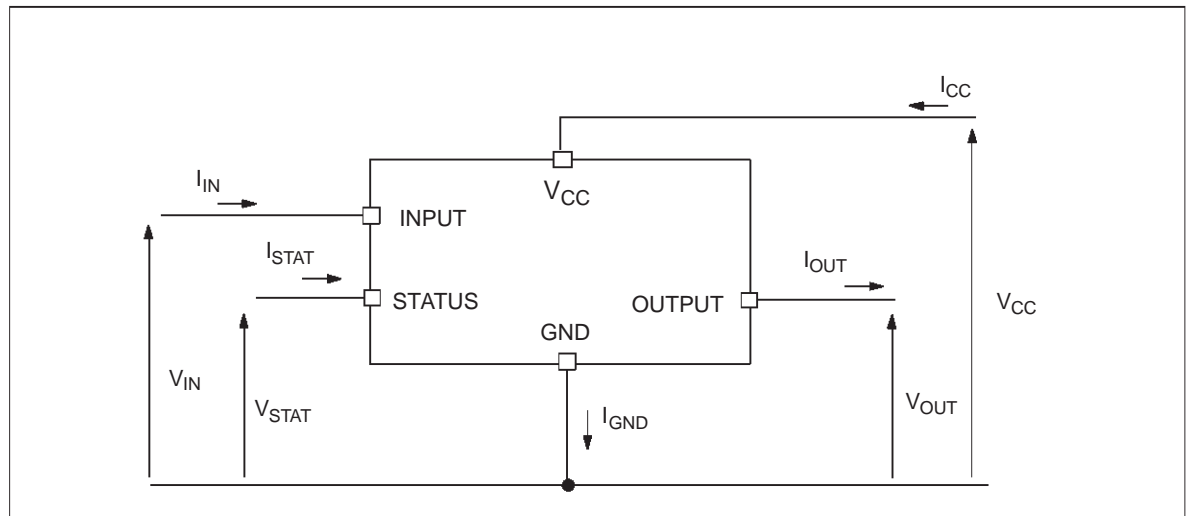

THERMAL DATA

Symbol	Parameter	Max	Value		Unit
			SO-8	PPAK	
R _{thj-case}	Thermal Resistance Junction-case	Max	-	3	°C/W
R _{thj-lead}	Thermal Resistance Junction-lead	Max	30	-	°C/W
R _{thj-amb}	Thermal Resistance Junction-ambient	Max	80 (*)	53 (**)	°C/W

(*) When mounted on FR4 printed circuit board with 0.5 cm² of copper area (at least 35μ thick) connected to all V_{CC} pins.

(**) When mounted on FR4 printed circuit board with 0.5 cm² of copper area (at least 35μ thick).

ELECTRICAL CHARACTERISTICS (8V < V_{CC} < 36V; -40°C < T_j < 150°C, unless otherwise specified)

POWER

Symbol	Parameter	Test Conditions	Min	Typ	Max	Unit
V _{CC}	Operating Supply Voltage		5.5		36	V
V _{USD}	Undervoltage Shut-down		3	4	5.5	V
V _{OV}	Overvoltage Shut-down		36	42	48	V
R _{ON}	On State Resistance	I _{OUT} = 0.5A; T _j = 25°C I _{OUT} = 0.5A			135 270	mΩ mΩ
I _S	Supply Current	Off State; V _{CC} = 24V; T _{case} = 25°C On State; V _{CC} = 24V On State; V _{CC} = 24V; T _{case} = 100°C		10 1.5	20 3.5	μA mA mA
I _{LGND}	Output Current at turn-off	V _{CC} = V _{STAT} = V _{IN} = V _{GND} = 24V V _{OUT} = 0V			1	mA
I _{L(off)}	Off State Output Current	V _{IN} = V _{OUT} = 0V	0		50	μA

SWITCHING (V_{CC} = 24V)

Symbol	Parameter	Test Conditions	Min	Typ	Max	Unit
t _{d(on)}	Turn-on Delay Time	R _L = 48Ω from V _{IN} rising edge to V _{OUT} = 2.4V		10		μs
t _{d(off)}	Turn-off Delay Time	R _L = 48Ω from V _{IN} falling edge to V _{OUT} = 21.6V		40		μs
dV _{OUT} /dt _(on)	Turn-on Voltage Slope	R _L = 48Ω from V _{OUT} = 2.4V to V _{OUT} = 19.2V		0.75		V/μs
dV _{OUT} /dt _(off)	Turn-off Voltage Slope	R _L = 48Ω from V _{OUT} = 21.6V to V _{OUT} = 2.4V		0.25		V/μs

INPUT PIN

Symbol	Parameter	Test Conditions	Min	Typ	Max	Unit
V _{INL}	Input Low Level				1.25	V
I _{INL}	Low Level Input Current	V _{IN} = 1.25V	1			μA
V _{INH}	Input High Level		3.25			V
I _{INH}	High Level Input Current	V _{IN} = 3.25V			10	μA
V _{I(hyst)}	Input Hysteresis Voltage		0.5			V
I _{IN}	Input Current	V _{IN} = V _{CC} = 36V			200	μA

VN800S / VN800PT

ELECTRICAL CHARACTERISTICS (continued)

STATUS PIN

Symbol	Parameter	Test Conditions	Min	Typ	Max	Unit
V_{STAT}	Status Low Output Voltage	$I_{STAT}=1.6\text{ mA}$			0.5	V
I_{LSTAT}	Status Leakage Current	Normal Operation; $V_{STAT}=V_{CC}=36\text{ V}$			10	μA
C_{STAT}	Status Pin Input Capacitance	Normal Operation; $V_{STAT}=5\text{ V}$			30	pF

PROTECTIONS

Symbol	Parameter	Test Conditions	Min	Typ	Max	Unit
T_{TSD}	Shut-down Temperature		150	175	200	$^{\circ}\text{C}$
T_R	Reset Temperature		135			$^{\circ}\text{C}$
T_{hyst}	Thermal Hysteresis		7	15		$^{\circ}\text{C}$
T_{SDL}	Status Delay in Overload Condition	$T_j > T_{jsh}$			20	μs
I_{lim}	DC Short Circuit Current	$V_{CC}=24\text{ V}$; $R_{LOAD}=10\text{ m}\Omega$	0.7		2	A
V_{demag}	Turn-off Output Clamp Voltage	$I_{OUT}=0.5\text{ A}$; $L=6\text{ mH}$	$V_{CC}-47$	$V_{CC}-52$	$V_{CC}-57$	V

OVERTEMP STATUS TIMING

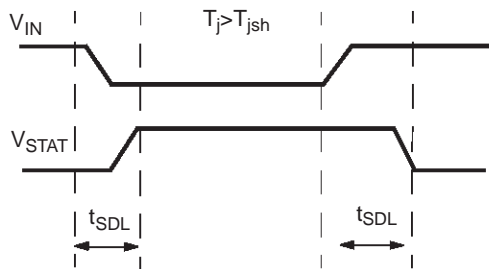

Switching time Waveforms

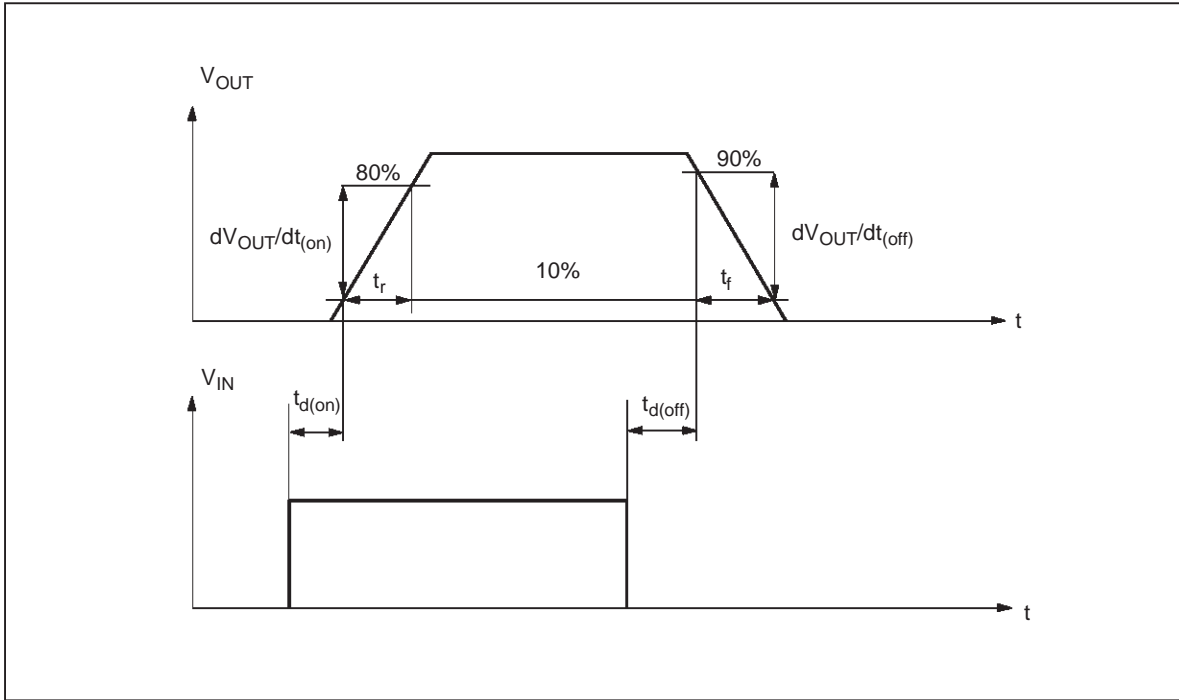

TRUTH TABLE

CONDITIONS	INPUT	OUTPUT	STATUS
Normal Operation	L	L	H
	H	H	H
Current Limitation	L	L	H
	H	X	H
Overtemperature	L	L	H
	H	L	L
Undervoltage	L	L	X
	H	L	X
Overvoltage	L	L	H
	H	L	H

Figure 1: Peak Short Circuit Current Test Circuit

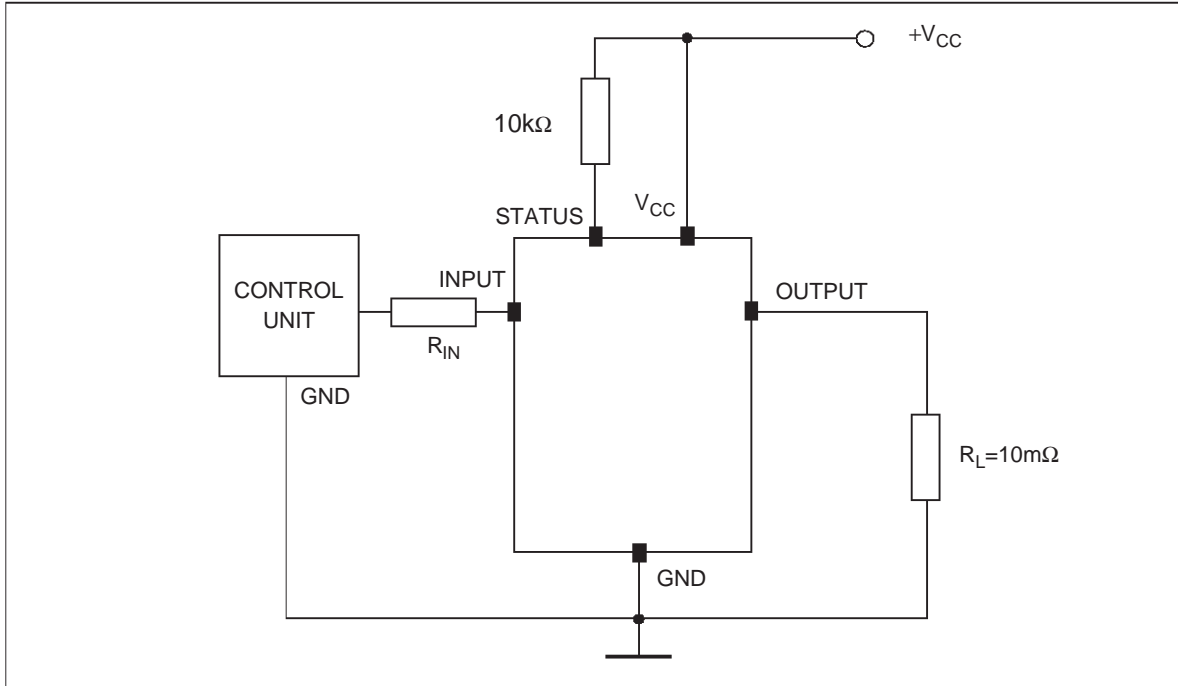
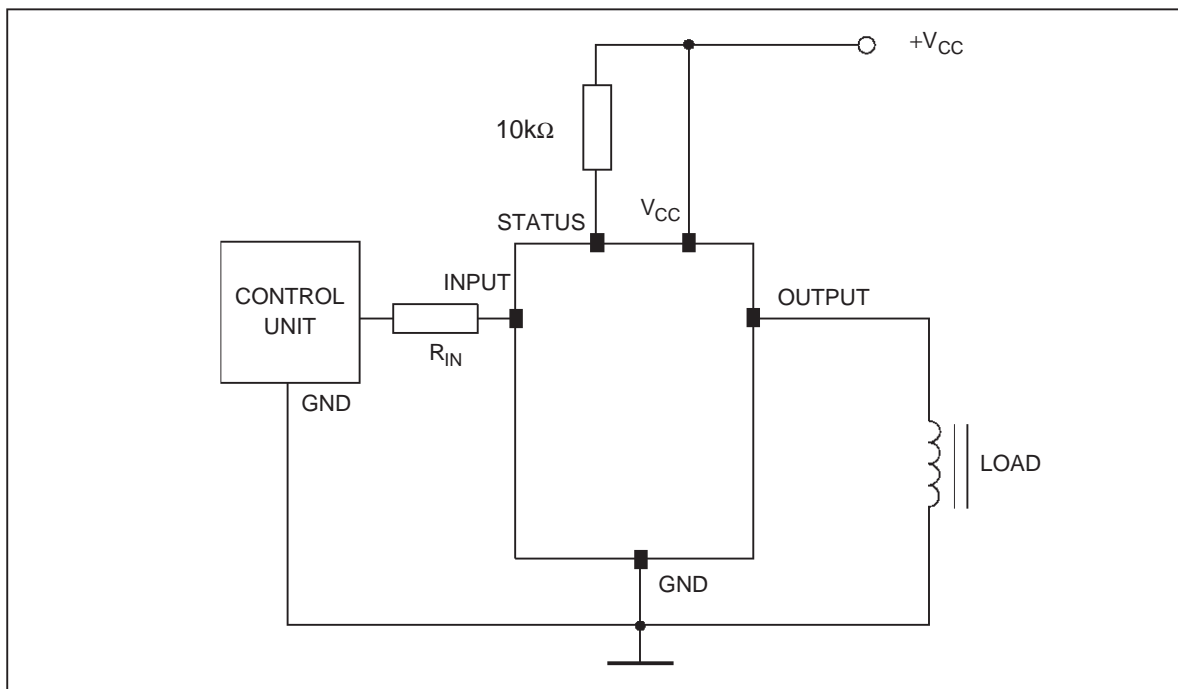

Figure 2: Avalanche Energy Test Circuit



ELECTRICAL TRANSIENT REQUIREMENTS ON V_{CC} PIN

ISO T/R 7637/1 Test Pulse	TEST LEVELS				Delays and Impedance
	I	II	III	IV	
1	-25 V	-50 V	-75 V	-100 V	2 ms 10 Ω
2	+25 V	+50 V	+75 V	+100 V	0.2 ms 10 Ω
3a	-25 V	-50 V	-100 V	-150 V	0.1 μs 50 Ω
3b	+25 V	+50 V	+75 V	+100 V	0.1 μs 50 Ω
4	-4 V	-5 V	-6 V	-7 V	100 ms, 0.01 Ω
5	+26.5 V	+46.5 V	+66.5 V	+86.5 V	400 ms, 2 Ω

ISO T/R 7637/1 Test Pulse	TEST LEVELS RESULTS			
	I	II	III	IV
1	C	C	C	C
2	C	C	C	C
3a	C	C	C	C
3b	C	C	C	C
4	C	C	C	C
5	C	E	E	E

CLASS	CONTENTS
C	All functions of the device are performed as designed after exposure to disturbance.
E	One or more functions of the device is not performed as designed after exposure to disturbance and cannot be returned to proper operation without replacing the device.

PROTECTING THE DEVICE AGAINST REVERSE BATTERY

The simplest way to protect the device against a continuous reverse battery voltage is to insert a resistor paralleled to a Schottky diode between the ground pin of the device and the ground of the system. The proposed

value for the resistance is 1KΩ. This way is suggested working with inductive loads. For resistive loads only, a suitable protection is to use one 150Ω resistor. In this case the value of the resistance is chosen by taking in account the current consumption through the ground pin.

Figure 3: Waveforms

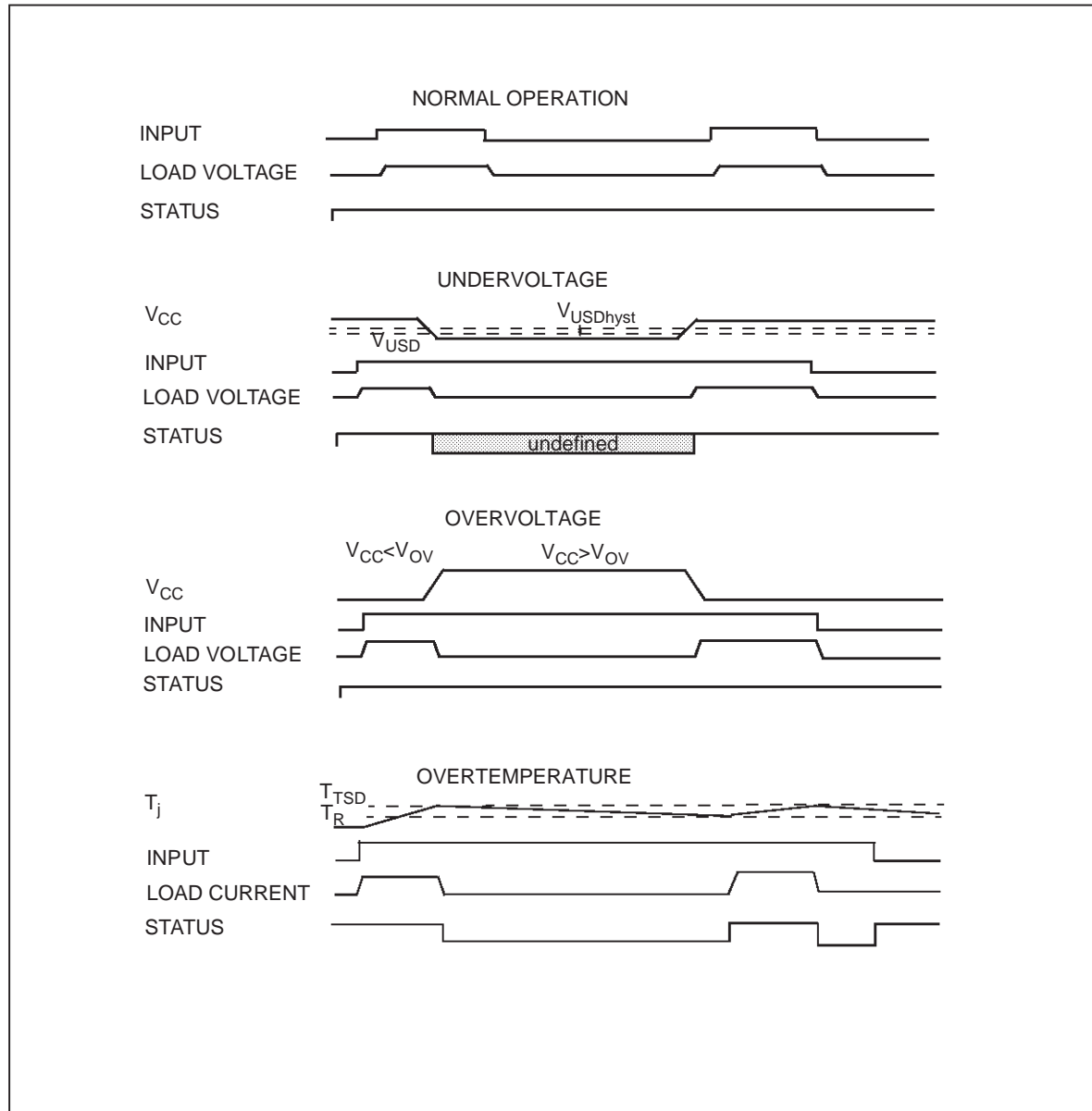

SO-8 MECHANICAL DATA

DIM.	mm.			inch		
	MIN.	TYP.	MAX.	MIN.	TYP.	MAX.
A			1.75			0.068
a1	0.1		0.25	0.003		0.009
a2			1.65			0.064
a3	0.65		0.85	0.025		0.033
b	0.35		0.48	0.013		0.018
b1	0.19		0.25	0.007		0.010
C	0.25		0.5	0.010		0.019
c1	45 (typ.)					
D	4.8		5	0.188		0.196
E	5.8		6.2	0.228		0.244
e		1.27			0.050	
e3		3.81			0.150	
F	3.8		4	0.14		0.157
L	0.4		1.27	0.015		0.050
M			0.6			0.023
S	8 (max.)					
L1	0.8		1.2	0.031		0.047

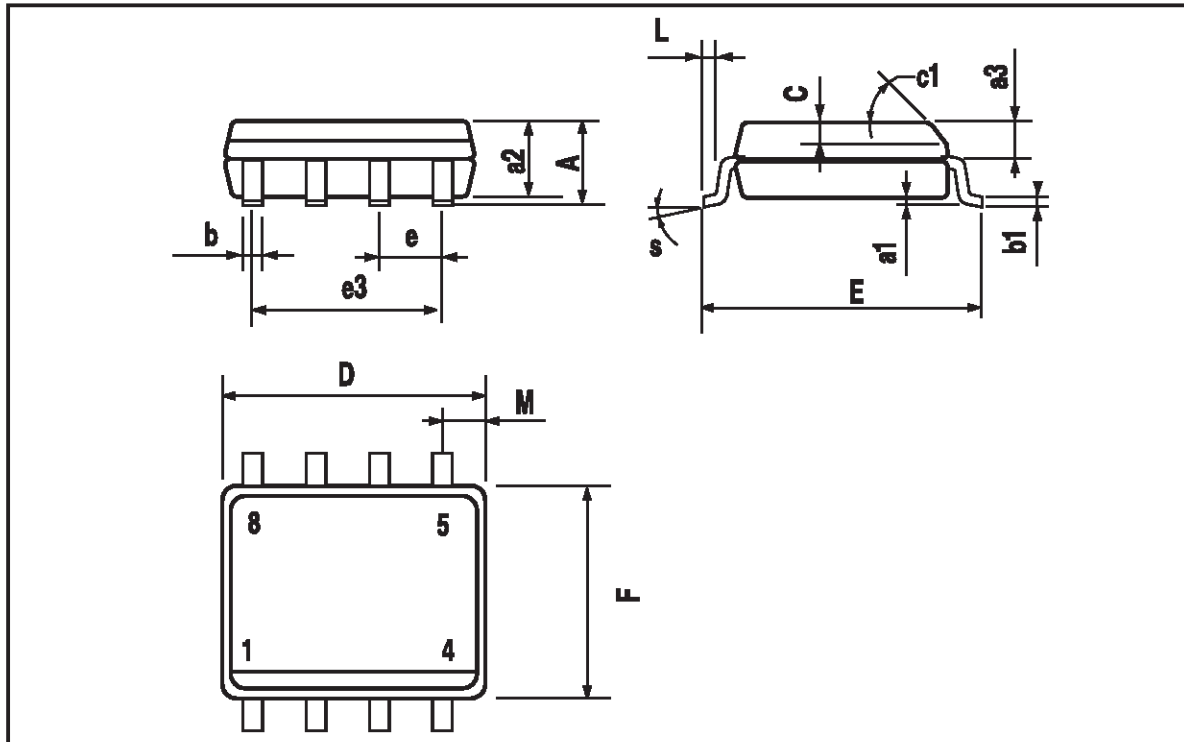

PPAK MECHANICAL DATA

DIM.	mm.			inch		
	MIN.	TYP	MAX.	MIN.	TYP.	MAX.
A	2.2		2.4	0.086		0.094
A1	0.9		1.1	0.035		0.043
A2	0.03		0.23	0.001		0.009
B	0.4		0.6	0.015		0.023
B2	5.2		5.4	0.204		0.212
C	0.45		0.6	0.017		0.023
C2	0.48		0.6	0.019		0.023
D	6		6.2	0.236		0.244
E	6.4		6.6	0.252		0.260
G	4.9		5.25	0.193		0.206
G1	2.38		2.7	0.093		0.106
H	9.35		10.1	0.368		0.397
L2		0.8	1		0.031	0.039
L4	0.6		1	0.031		0.039

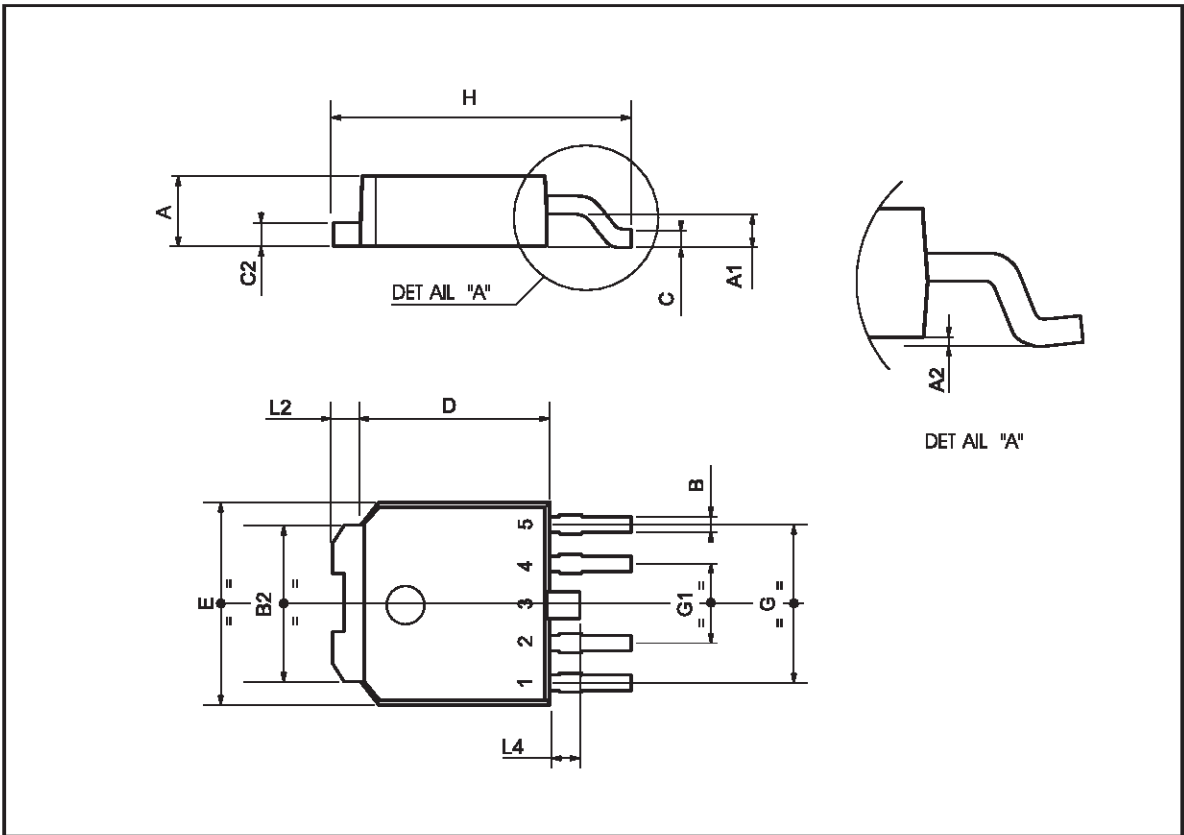

SO-8 TUBE SHIPMENT (no suffix)

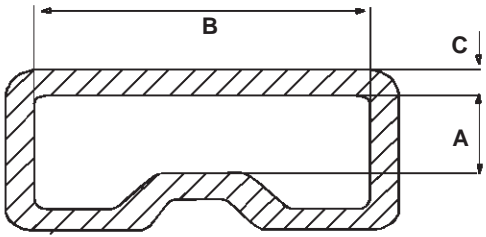

Base Q.ty	100
Bulk Q.ty	2000
Tube length (± 0.5)	532
A	3.2
B	6
C (± 0.1)	0.6

All dimensions are in mm.

TAPE AND REEL SHIPMENT (suffix "13TR")

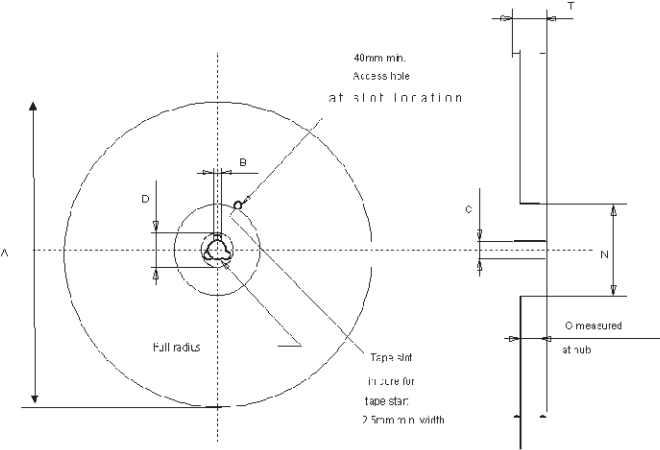

Base Q.ty	2500
Bulk Q.ty	2500
A (max)	330
B (min)	1.5
C (± 0.2)	13
F	20.2
G (+ 2 / - 0)	12.4
N (min)	60
T (max)	18.4

All dimensions are in mm.

TAPE DIMENSIONS

According to Electronic Industries Association (EIA) Standard 481 rev. A, Feb 1986

Tape width	W	12
Tape Hole Spacing	P0 (± 0.1)	4
Component Spacing	P	8
Hole Diameter	D (± 0.1/-0)	1.5
Hole Diameter	D1 (min)	1.5
Hole Position	F (± 0.05)	5.5
Compartment Depth	K (max)	4.5
Hole Spacing	P1 (± 0.1)	2

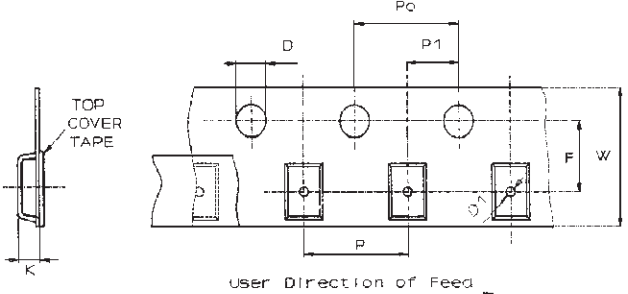

All dimensions are in mm.

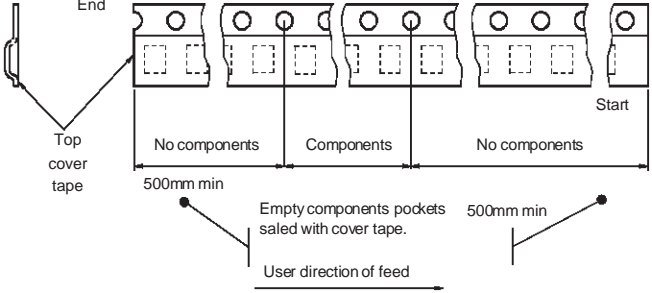

PPAK TUBE SHIPMENT (no suffix)

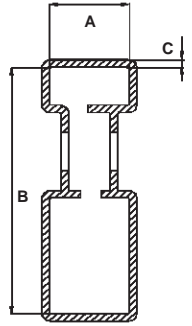

Base Q.ty	75
Bulk Q.ty	3000
Tube length (± 0.5)	532
A	6
B	21.3
C (± 0.1)	0.6

All dimensions are in mm.

TAPE AND REEL SHIPMENT (suffix "13TR")

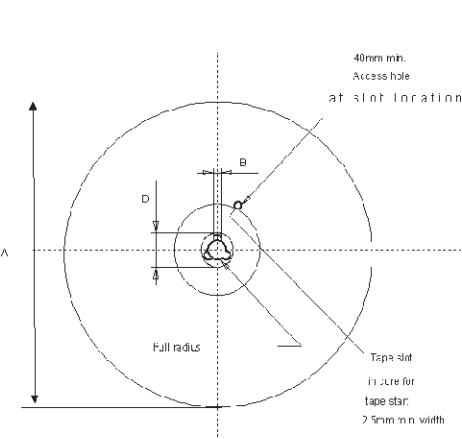
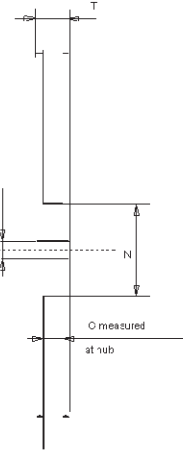
Base Q.ty	2500
Bulk Q.ty	2500
A (max)	330
B (min)	1.5
C (± 0.2)	13
F	20.2
G (+ 2 / - 0)	16.4
N (min)	60
T (max)	22.4

All dimensions are in mm.

TAPE DIMENSIONS

According to Electronic Industries Association (EIA) Standard 481 rev. A, Feb 1986

Tape width	W	16
Tape Hole Spacing	P0 (± 0.1)	4
Component Spacing	P	8
Hole Diameter	D ($\pm 0.1/-0$)	1.5
Hole Diameter	D1 (min)	1.5
Hole Position	F (± 0.05)	7.5
Compartment Depth	K (max)	6.5
Hole Spacing	P1 (± 0.1)	2

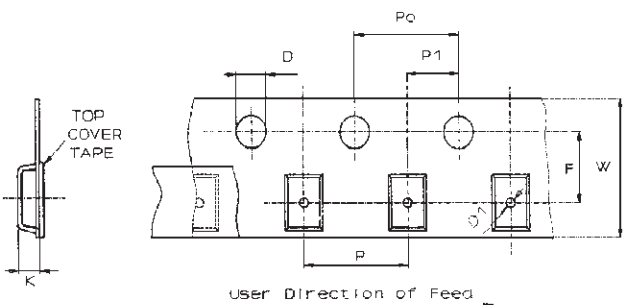

All dimensions are in mm.

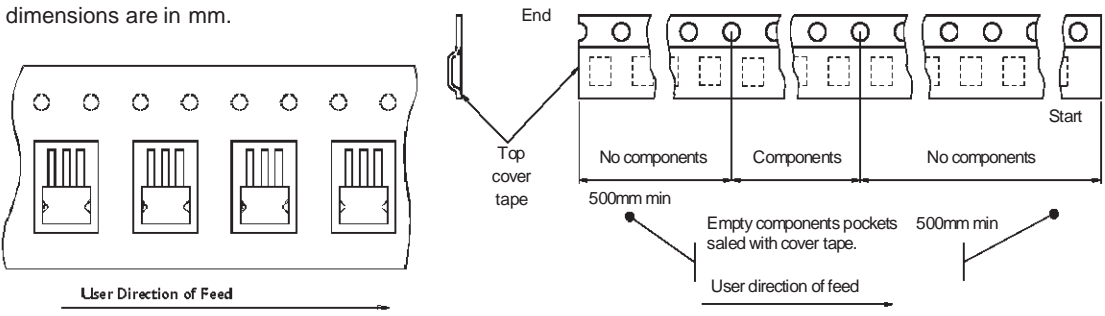

Empty components pockets sealed with cover tape.

Information furnished is believed to be accurate and reliable. However, STMicroelectronics assumes no responsibility for the consequences of use of such information nor for any infringement of patents or other rights of third parties which may result from its use. No license is granted by implication or otherwise under any patent or patent rights of STMicroelectronics. Specifications mentioned in this publication are subject to change without notice. This publication supersedes and replaces all information previously supplied. STMicroelectronics products are not authorized for use as critical components in life support devices or systems without express written approval of STMicroelectronics. The ST logo is a trademark of STMicroelectronics

© 2000 STMicroelectronics - Printed in ITALY- All Rights Reserved.

STMicroelectronics GROUP OF COMPANIES

Australia - Brazil - China - Finland - France - Germany - Hong Kong - India - Italy - Japan - Malaysia - Malta - Morocco - Singapore - Spain - Sweden - Switzerland - United Kingdom - U.S.A.

<http://www.st.com>